

AZ Displays, Inc.

1. MECHANICAL DATA

(1) Part Name	AGM2464C
(2) Module Size	180.0(W)mm X 65.0(H)mm X MAX9.5(D)mm (W/O,EL B/L) 180.0(W)mm X 65.0(H)mm X MAX14.5(D)mm (LED B/L) 190.0(W)mm X 65.0(H)mm X MAX13.8(D)mm (CCFL B/L)
(3) Dot Size	0.49 (W)mm x 0.49 (H)mm
(4) Dot Pitch	0.53 (W)mm x 0.53 (H)mm
(5) Number of Dots	240 (W) x 64 (H)Dots
(6) Duty	1/64
(7) LCD Display Mode	STN: <input type="checkbox"/> Gray Mode <input type="checkbox"/> Yellow Mode <input type="checkbox"/> Blue Mode Rear Polarizer: <input type="checkbox"/> Reflective <input type="checkbox"/> Transflective <input type="checkbox"/> Transmissive
(8) Viewing Direction	<input type="checkbox"/> 6 O'clock <input type="checkbox"/> 12 O'clock
(9) Backlight	<input type="checkbox"/> W/O <input type="checkbox"/> EL B/L <input type="checkbox"/> LED B/L <input type="checkbox"/> CCFL B/L
(10) Weight	W/O B/L: 128.5 g EL B/L: 135.5 g LED B/L: 164.0 g CCFL B/L: 173.0 g

Revised: July 7, 2000

AZ Displays, Inc.

2. ABSOLUTE MAXIMUM RATINGS

(1) ELECTRICAL ABSOLUTE RATINGS

VSS=0V Standard

ITEM	SYMBOL	MIN	MAX	UNIT	COMMENT
Power Supply for Logic	VDD-VSS	-0.3	7.0	V	
Input Voltage	VI	-0.3	VDD	V	
Static Electricity	-	-	-	-	Note 1

(2) ENVIRONMENTAL ABSOLUTE MAXIMUM RATINGS

ITEM	NORMAL TEMP.				WIDE TEMP.			
	OPERATING		STORAGE		OPERATING		STORAGE	
	MIN.	MAX.	MIN.	MAX.	MIN.	MAX.	MIN.	MAX.
Ambient Temperature	0	50	-20	70	-20	70	-30	80
Humidity (Without Condensation)	Note 2,4		Note 3,4		Note 4,5		Note 4,6	

Note 1 LCM should be grounded during handling

Note 2 $T_a \leq 50^\circ\text{C}$: 85%RH max

$T_a > 50^\circ\text{C}$: Absolute humidity must be lower
than the humidity of 85%RH at 50°C

Note 3 T_a at -20°C will be $< 48\text{hrs}$, at 70°C will be $< 120\text{hrs}$

Note 4 Background color changes slightly depending on ambient temperature.
This phenomenon is reversible.

Note 5 $T_a \leq 70^\circ\text{C}$: 75%RH max

$T_a > 70^\circ\text{C}$: Absolute humidity must be lower
than the humidity of 75%RH at 70°C

Note 6 T_a at -30°C will be $< 48\text{hrs}$, at 80°C will be $< 120\text{hrs}$

AZ Displays, Inc.

3. ELECTRICAL CHARACTERISTICS (VDD = 5V±10%)

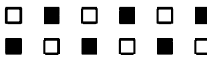
ITEM	SYMBOL	CONDITION	MIN.	TYP.	MAX.	UNIT	
Input Voltage	V _{IH}	H level	0.7VDD	–	VDD	V	
	V _{IO}	L level	0	–	0.3VDD	V	
Recommended LC Driving Voltage (Normal Temp. LCM)	VDD–VO	Duty= 1/64	0°C	–	13.3	13.8	V
			25°C	11.7	12.5	13.1	
		Bias= 1/9	50°C	10.8	11.4	–	
Recommended LC Driving Voltage (Wide Temp. LCM)	VDD–VO	Duty= 1/64 Bias= 1/9	–20°C	11.7	12.1	12.5	V
			0°C	11.6	12.0	12.4	
			25°C	11.5	11.9	12.3	
			50°C	11.4	11.8	12.2	
			70°C	11.3	11.7	12.1	
Power Supply Current	I _{DD}	FLM=70 Hz VDD=5.0 V VDD–VO=12.5 V PATTERN : 	–	18.5	–	mA	
EL Power Supply Current	I _{EL}	V _{BL} = 110 V _{rms} 400 Hz (R _{BL} = 0 Ω)	–	–	10.0	mA _{rms}	
LED Power Supply Current	I _{LED}	V _{BL} = 5.0 V (R _{BL} = 5 Ω)	–	220	–	mA	
CCFL	Starting Voltage	V _{FLS}	–	–	900	–	V _{rms}
	Driving Voltage	V _{FLD}	–	–	450	–	V _{rms}
	Driving Current	I _{FLD}	V _{FLD} = 450V _{rms} f _{FLD} = 30KHZ	–	5.0	–	mA _{rms}
	Driving Voltage	f _{FL}	–	15	30	50	KHZ

AZ Displays, Inc.

4. OPTICAL CHARACTERISTICS

4-1 Optical Char. of Normal Temp. Mode

AT V_{OP}

ITEM MODE		Cr(Contrast Ratio)		θ (Viewing Angle)		ϕ (Viewing Angle)	
		25°C		25°C		25°C	
		MIN.	TYP.	MIN.	TYP.	MIN.	TYP.
R	C	—	7.5	—	80	—	35
S	B	—	4.2	—	70	—	30
	C	—	6.5	—	75	—	35
T	E	—	4.0	—	70	—	35
note		NOTE6		NOTE5			

note:

R: REFLECTIVE
S: TRANSFLECTIVE
T: TRANSMISSIVE

B: GRAY 12 O'CLOCK
C: YELLOW 6 O'CLOCK
E: BLUE 6 O'CLOCK

AT $\phi=0^\circ$ $\theta=0^\circ$

ITEM	SYMBOL	CONDITION	MIN.	TYP.	MAX.	UNIT	NOTE
Response Time (rise)	Tr	0°C	—	600	1200	ms	NOTE 2
		25°C	—	110	220		
		50°C	—	50	100		
Response Time (fall)	Tf	0°C	—	900	1500	ms	NOTE 2
		25°C	—	250	360		
		50°C	—	100	150		

AZ Displays, Inc.

4-2 Optical Char. of Wide Temp. Mode

AT V_{OP}

ITEM		Cr(Contrast Ratio)		θ (Viewing Angle)		ϕ (Viewing Angle)	
		25°C		25°C		25°C	
MODE		MIN.	TYP.	MIN.	TYP.	MIN.	TYP.
R	C	—	7.0	—	60	—	65
S	C	—	6.5	—	56	—	64
note		NOTE6			NOTE5		

note:

R: REFLECTIVE
S: TRANSFLECTIVE

C: YELLOW 6 O'CLOCK

AT $\phi=0^\circ$ $\theta=0^\circ$

ITEM	SYMBOL	CONDITION	MIN.	TYP.	MAX.	UNIT	NOTE
Response Time (rise)	Tr	-20°C	—	2100	3200	ms	NOTE 2
		0°C	—	450	680		
		25°C	—	150	250		
		50°C	—	110	170		
		70°C	—	70	90		
Response Time (fall)	Tf	-20°C	—	2100	3200	ms	NOTE 2
		0°C	—	400	600		
		25°C	—	120	180		
		50°C	—	60	100		
		70°C	—	30	50		

AZ Displays, Inc.

(FIG 1)

Definition of Operation Voltage(Vop)

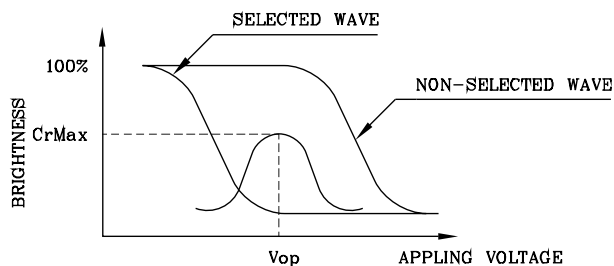

(positive type)

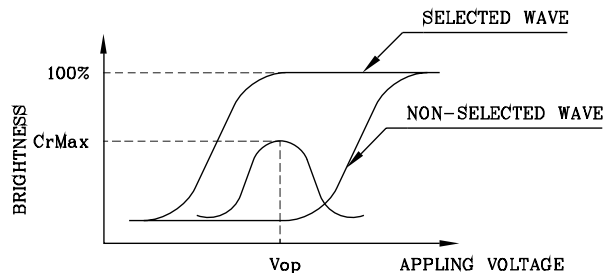

(negative type)

*Conditions

Viewing Angle : 0
 Frame Frequency : 70Hz
 Applying Waveform : 1/N duty 1/a bias

(FIG 2)

Definition of Response Time(Tr,Tf)

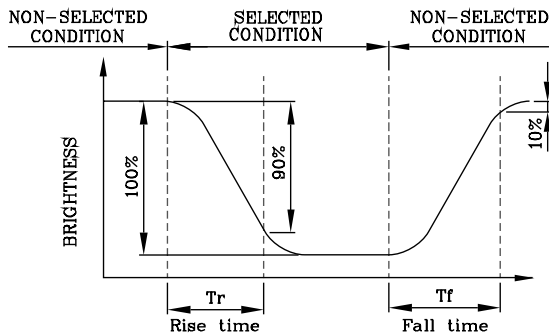

(positive type)

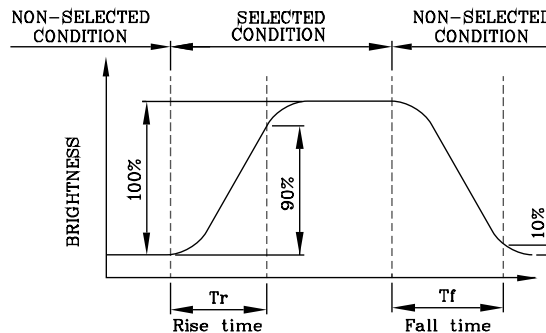

(negative type)

*Conditions

Operating Voltage : Vop
 Viewing Angle (θ,φ) : (0,0)
 Frame Frequency : 70Hz
 Applying Waveform : 1/N duty 1/a bias

(FIG 3)

Description of Measuring Equipment and Driving Waveforms

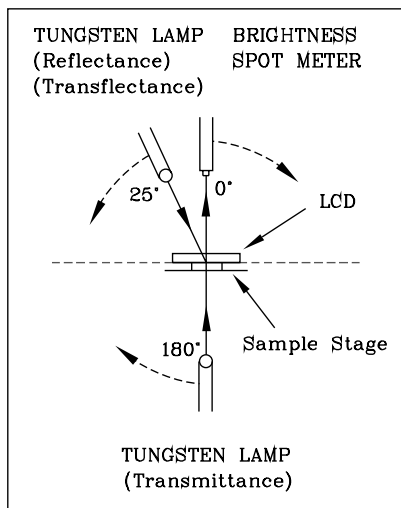

CONST.
TEMP.
CHAMBER

Multiplex Driving (1/N duty 1/a bias)

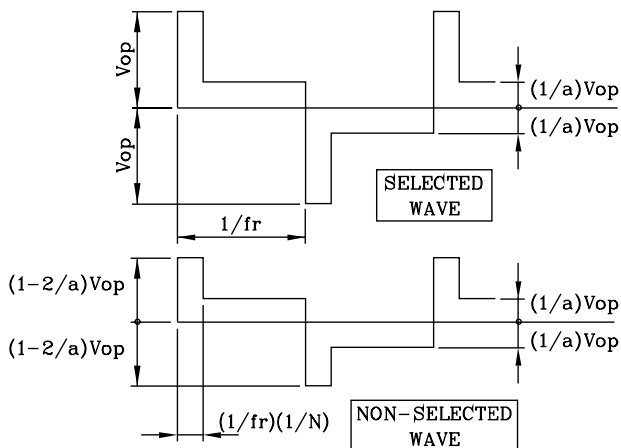

AZ Displays, Inc.

(NOTE 4)

Definition of Viewing Direction

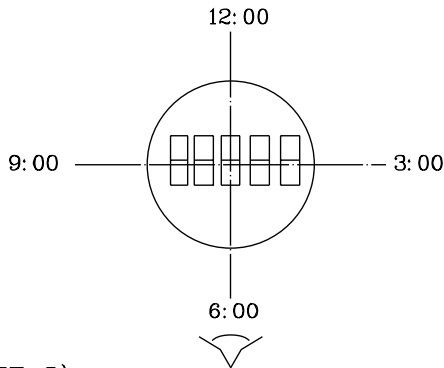

(NOTE 5)

Definition of Viewing Angle

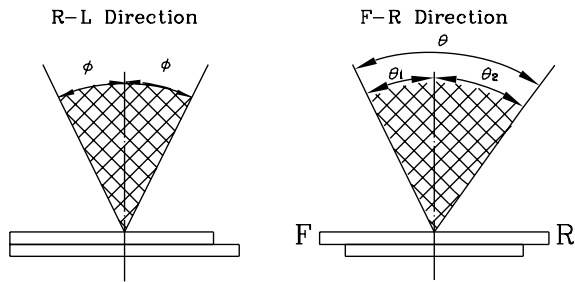

*For This Product
The Viewing Direction Is 6 O'clock
So $\theta_1 > \theta_2$

$$\theta = \theta_1 + \theta_2$$

*Conditions

Operating Voltage : V_{op}
Frame Frequency : 70Hz
Applying Waveform : 1/N duty 1/a bias
Contrast Ratio : larger than 2

(NOTE 6)

Definition of Contrast Ratio (Cr)

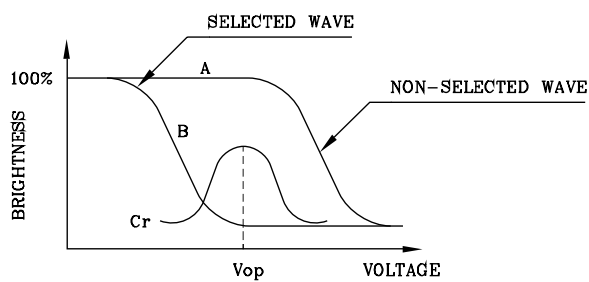

(positive type)

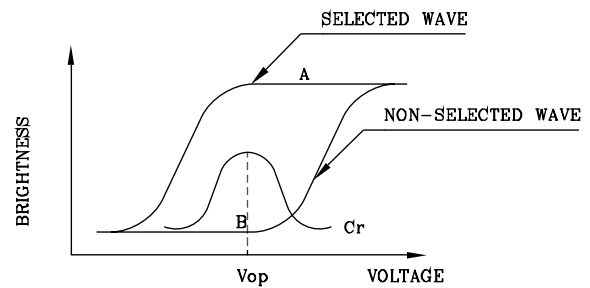

(negative type)

$$\text{Contrast Ratio : } Cr = A/B$$

*Conditions

Viewing Angle : 0
Frame Frequency : 70Hz
Applying Waveform : 1/N duty 1/a bias

AZ Displays, Inc.

5. BLOCK DIAGRAM

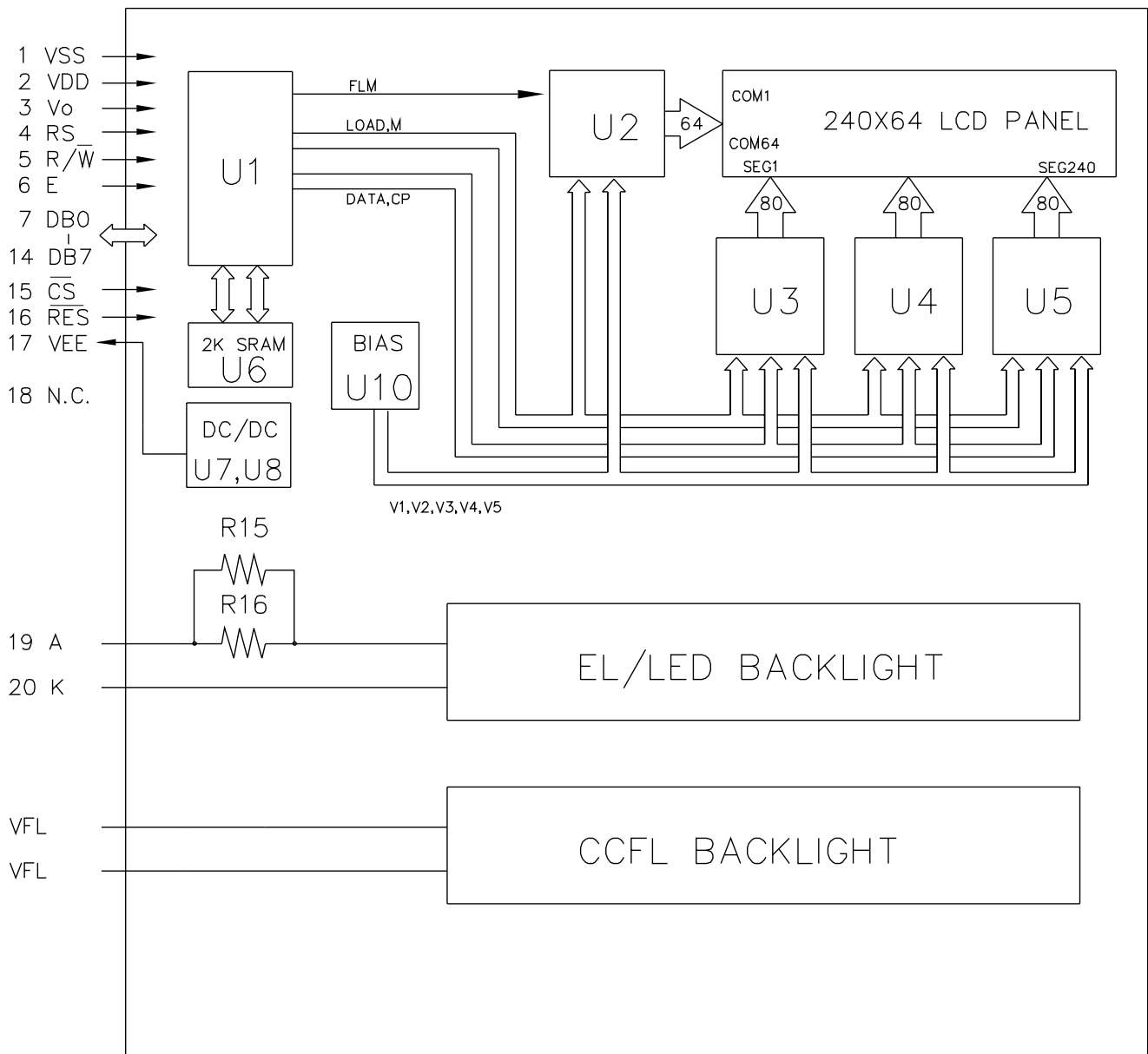

R15=R16=10Ω (LED B/L)
 R15=0Ω ,R16=OPEN (EL B/L)

AZ Displays, Inc.

6. INTERNAL PIN CONNECTION

PinNo.	Symbol	Level	Function
1	V _{SS}	—	0V
2	V _{DD}	—	+5V
3	V _O	—	—
4	RS	H/L	H: INSTRUCTION CODE INPUT L: DATA INPUT
5	R/ \bar{W}	H/L	H: DATA READ (LCM TO MPU) L: DATA WRITE (MPU TO LCM)
6	E	H, H→L	ENABLE SIGNAL
7	DB0	H/L	DATA BUS LINE
8	DB1	H/L	
9	DB2	H/L	
10	DB3	H/L	
11	DB4	H/L	
12	DB5	H/L	
13	DB6	H/L	
14	DB7	H/L	
15	\bar{CS}	L	CHIP ENABLE ACTIVE "L"
16	\bar{RES}	L	RESET ACTIVE "L"
17	VEE	—	NEGATIVE VOLTAGE OUTPUT
18	N.C.	—	NO CONNECTION
19	A	—	POWER SUPPLY FOR BACKLIGHT
20	K	—	POWER GND FOR BACKLIGHT

CCFL Connector : J.A.E/IL-G-4S-S3C2

PIN NO	SYMBOL	FUNCTION
1	VFL	POWER SUUPLY FOR CCFL DRIVE
2	NC	—
3	NC	—
4	VFL	POWER SUUPLY FOR CCFL DRIVE

AZ Displays, Inc.

7. POWER SUPPLY

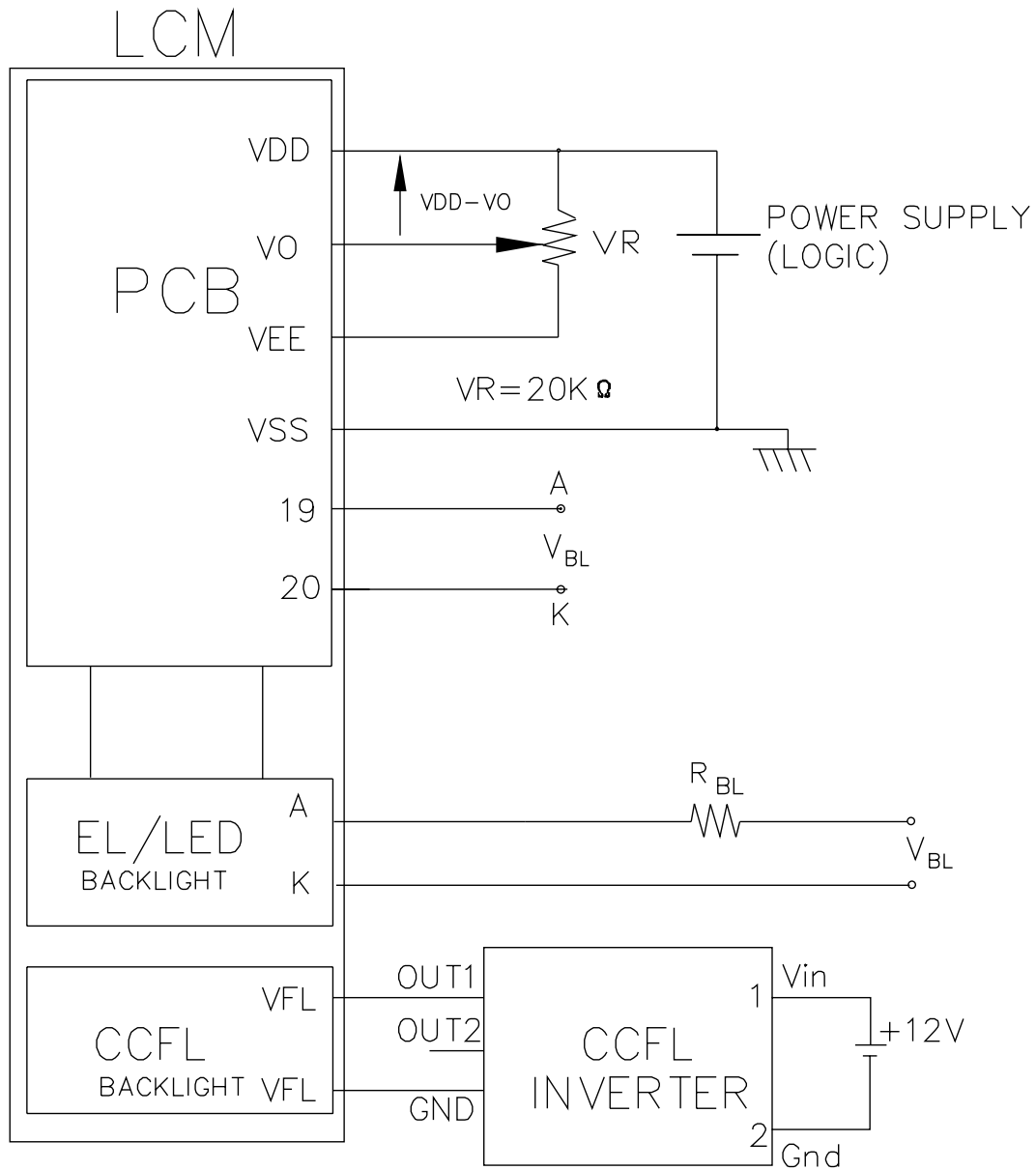

Recommended Inverter : CXA-L10L (TDK)

Recommended Value for R_{BL} and V_{BL}

ITEM Back Light Interface	R _{BL}		V _{BL}	
	EL	LED	EL	LED
A,K PAD	0 Ω	5 Ω	110 V _{Ac} 400Hz	5V _{Dc}

AZ Displays, Inc.

8. TIMING CHARACTERISTICS

8-1 INTERFACE TIMING

Item	Symbol	Test condition	Min.	Typ.	Max.	Unit
Enable cycle time	t_{cyc}	Fig.a, Fig.b	1.0	-	-	us
Enable pulse width	PW_{EH}	Fig.a, Fig.b	450	-	-	ns
Enable rise/fall time	t_{Er}, t_{Ef}	Fig.a, Fig.b	-	-	25	ns
RS,R/W set up time	t_{AS}	Fig.a, Fig.b	140	-	-	ns
Data delay time	t_{DDR}	Fig.b	-	-	225	ns
Data set up time	t_{DSW}	Fig.a	225	-	-	ns
Hold time	t_H	Fig.a, Fig.b	20	-	-	ns

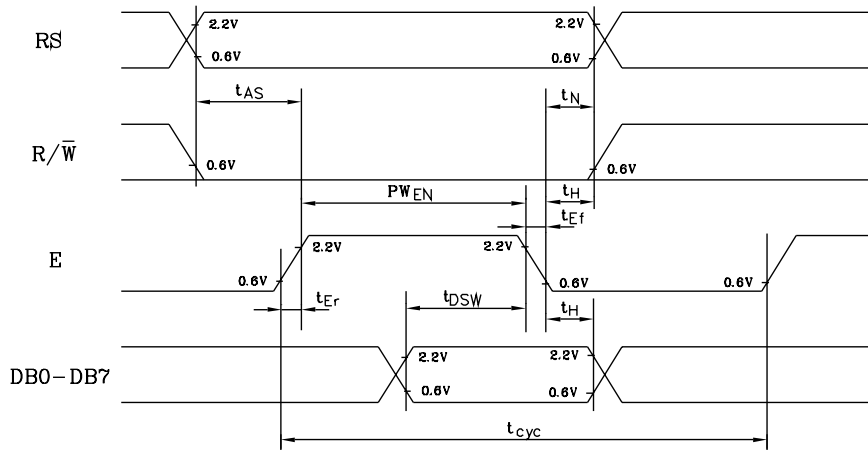

Fig. a Interface timing (data write)

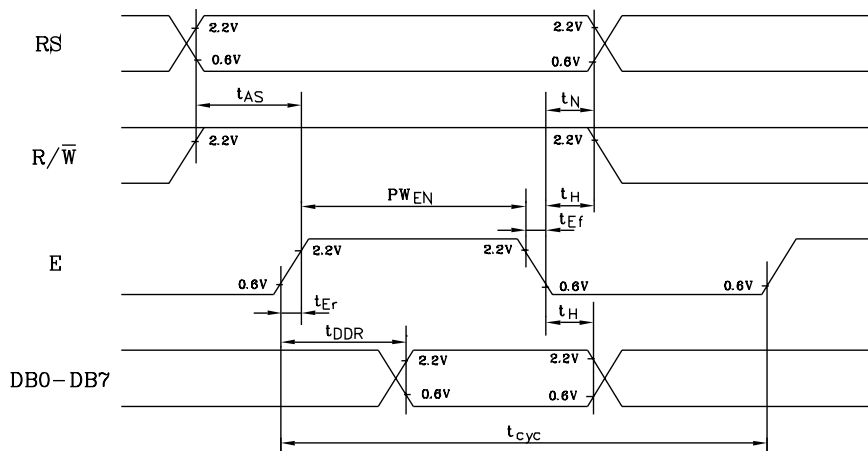
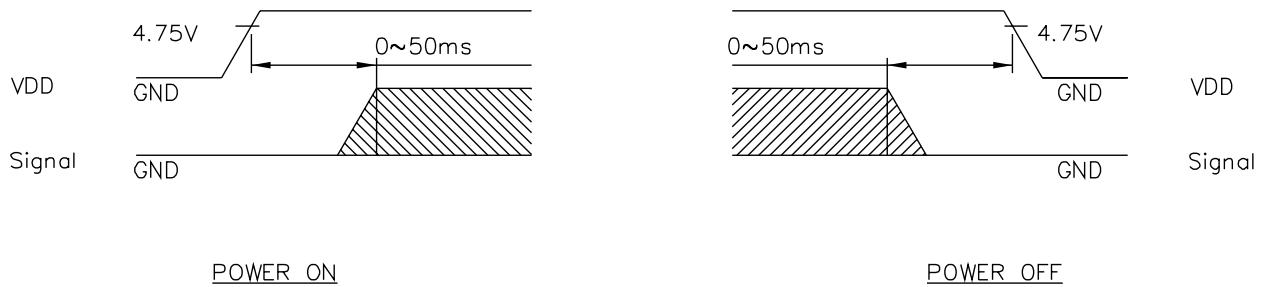

Fig. b Interface timing (data read)

AZ Displays, Inc.

8-2 POWER ON/OFF TIMING



Missing pixels may occur when the LCM is driven beyond above power interface timing sequence.

8-3 DISPLAY PATTERN

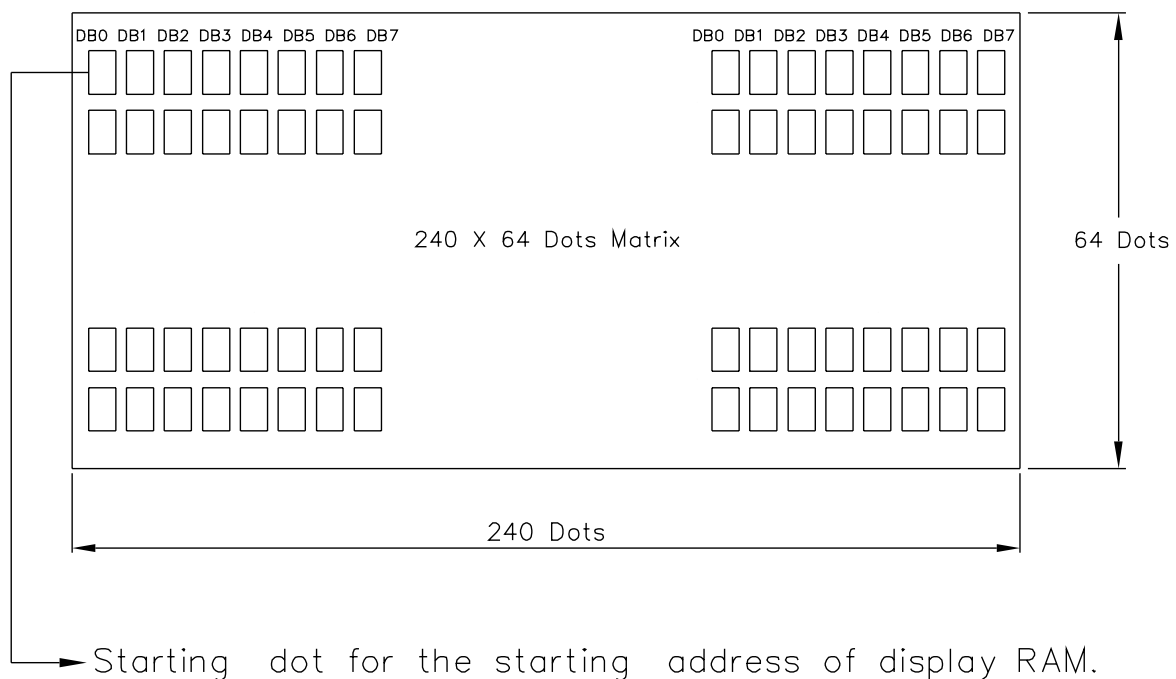

DB0~DB7 are 8 bits transmitted data ,where DB0 is LSB and DB7 is MSB.

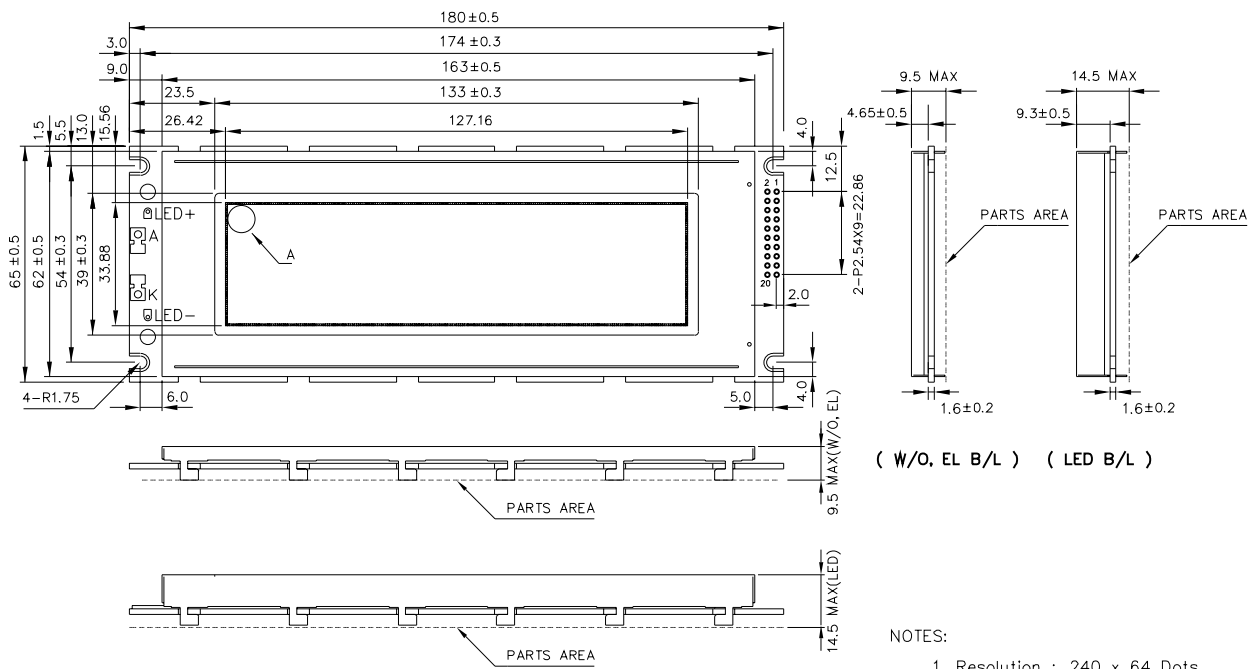

(W/O. EL B/L) (LED B/L)

- NOTES:
- Resolution : 240 x 64 Dots
 - Controller : LC7981(Compatible)
 - DC/DC Converter : BUILT-IN
 - Bezel Material : SPCC
 - General Tolerance : ±0.5 mm

PIN NO.	SYMBOL
1	V _{SS}
2	V _{DD}
3	V _O
4	RS
5	R/W
6	E
7-14	DB0-DB7
15	CS
16	RES
17	V _E
18	N.C.
19	A
20	K

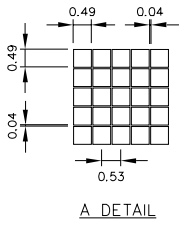

AGM2464C		AZ DISPLAYS, INC.		
APPROVE	NAME	DATE	TITLE	
CHECK			DWG-NO	MXAX003X
DESIGN			Rev.	A
DRAW	MAY PING	87.10.12	UNIT : mm	SCALE : 1/1

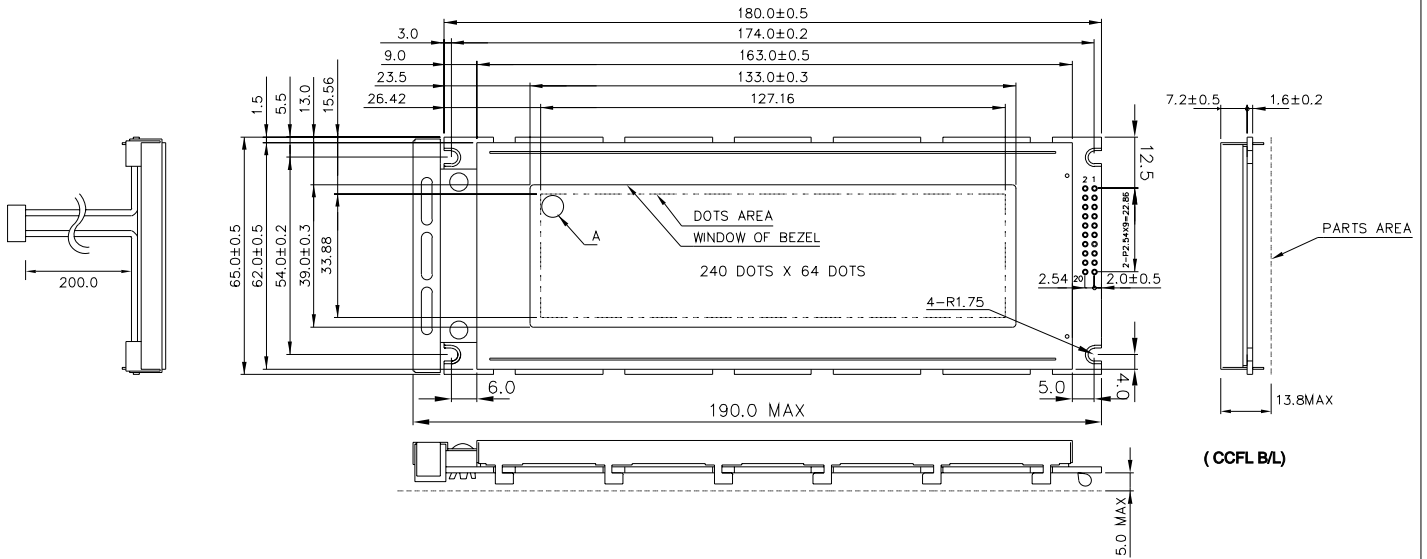

NOTES:

- Resolution : 240 x 64 Dots
- Controller : LC7981(Compatible)
- DC/DC Converter : BUILT-IN
- Bezel Material : SPCC
- General Tolerance : ±0.5 mm

PIN NO.	SYMBOL
1	VSS
2	VDD
3	Vo
4	RS
5	R/W
6	E
7-14	DBO-DB7
15	CS
16	RES
17	VEE
18	N.C.
19	A
20	K

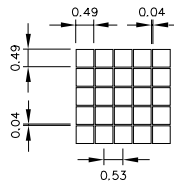

A DETAIL

AGM2464C			AZ DISPLAYS, INC.		
APPROVE	NAME	DATE	TITLE		
CHECK			DWG-NO	MBAX003X	Rev.A
DESIGN			UNIT : mm		
DRAW	MAY PING	88.02.11	SCALE : 1/1		