

AZ Displays, Inc.

1. MECHANICAL DATA

(1) Part Name	AGM2464D
(2) Module Size	180.0(W)mm X 65.0(H)mm X MAX10.5(D)mm (W/O,EL B/L) 180.0(W)mm X 65.0(H)mm X MAX15.5(D)mm (LED B/L) 190.0(W)mm X 65.0(H)mm X MAX13.8(D)mm (CCFL B/L)
(3) Dot Size	0.49 (W)mm x 0.49 (H)mm
(4) Dot Pitch	0.53 (W)mm x 0.53 (H)mm
(5) Number of Dots	240 (W) x 64 (H)Dots
(6) Duty	1/64
(7) LCD Display Mode	STN: <input type="checkbox"/> Gray Mode <input type="checkbox"/> Yellow Mode <input type="checkbox"/> Blue Mode FSTN: <input type="checkbox"/> Black and White(Normal White/Positive Image) <input type="checkbox"/> Black and White(Normal Black/Negative Image) Rear Polarizer: <input type="checkbox"/> Reflective <input type="checkbox"/> Transflective <input type="checkbox"/> Transmissive
(8) Viewing Direction	<input type="checkbox"/> 6 O'clock <input type="checkbox"/> 12 O'clock <input type="checkbox"/> ____ O'clock
(9) Backlight	<input type="checkbox"/> W/O <input type="checkbox"/> EL B/L <input type="checkbox"/> LED B/L <input type="checkbox"/> CCFL B/L
(10) Weight	W/O B/L: 128.5 g EL B/L: 135.5 g LED B/L: 164.0 g CCFL B/L: 173.0 g

AZ Displays, Inc.

2. ABSOLUTE MAXIMUM RATINGS

(1) ELECTRICAL ABSOLUTE RATINGS

VSS=0V Standard

ITEM	SYMBOL	MIN	MAX	UNIT	COMMENT
Power Supply for Logic	VDD-VSS	-0.3	7.0	V	
Power Supply for LCM	VDD-VEE	0	20.0	V	
Input Voltage	VI	-0.3	VDD	V	
Static Electricity	-	-	-	-	Note 1

Note 1 LCM should be grounded during handling

(2) ENVIRONMENTAL ABSOLUTE MAXIMUM RATINGS

ITEM	NORMAL TEMP.				WIDE TEMP.			
	OPERATING		STORAGE		OPERATING		STORAGE	
	MIN.	MAX.	MIN.	MAX.	MIN.	MAX.	MIN.	MAX.
Ambient Temperature	0	50	-20	70	-20	70	-30	80
Humidity (Without Condensation)	Note 2,4		Note 3,5		Note 4,5		Note 4,6	

Note 2 $T_a \leq 50^\circ\text{C}$: 85%RH max

$T_a > 50^\circ\text{C}$: Absolute humidity must be lower
than the humidity of 85%RH at 50°C

Note 3 T_a at -20°C will be $< 48\text{hrs}$, at 70°C will be $< 120\text{hrs}$

Note 4 Background color changes slightly depending on ambient temperature.
This phenomenon is reversible.

Note 5 $T_a \leq 70^\circ\text{C}$: 75%RH max

$T_a > 70^\circ\text{C}$: Absolute humidity must be lower
than the humidity of 75%RH at 70°C

Note 6 T_a at -30°C will be $< 48\text{hrs}$, at 80°C will be $< 120\text{hrs}$

AZ Displays, Inc.

3. ELECTRICAL CHARACTERISTICS (VDD = 5V±10%)

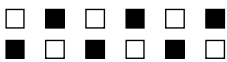
ITEM		SYMBOL	CONDITION	MIN.	TYP.	MAX.	UNIT	
Input Voltage		VIH	H level	0.7VDD	–	VDD	V	
		VIO	L level	0	–	0.3VDD	V	
Recommended LC Driving Voltage (Normal Temp. LCM)		VDD–VEE	Duty= 1/64	0°C	13.1	13.5	13.9	V
				25°C	11.9	12.5	13.1	
			Bias= 1/9	50°C	10.8	11.4	11.8	
Recommended LC Driving Voltage (Wide Temp. LCM)		VDD–VEE	Duty= 1/64	–20°C	11.7	12.1	12.5	V
				0°C	11.6	12.0	12.4	
			Bias= 1/9	25°C	11.5	11.9	12.3	
				50°C	11.4	11.8	12.2	
				70°C	11.3	11.7	12.1	
Power Supply Current		IDD	FLM=72 Hz VDD=5.0 V VDD–VEE=11.6 V	6.5	7.2	10.6	mA	
		IEE	PATTERN : 	1.6	1.8	2.4		
LED Power Supply Current		I _{LED}	V _{AK} = 5.0 V R ₁₈ = R ₁₉ = 10Ω	–	220	–	mA	
EL Power Supply Current		I _{EL}	V _{AK} = 110 V _{rms} 400HZ R ₁₈ = R ₁₉ = 0Ω	–	–	10.0	mA rms	
CCFL	Starting Voltage	V _{FLS}	–	–	900	–	V _{rms}	
	Driving Voltage	V _{FLD}	–	–	450	–	V _{rms}	
	Driving Current	I _{FLD}	V _{FLD} = 450V _{rms} f _{FLD} = 30KHZ	–	5.0	–	mA rms	
	Driving Voltage	f _{FL}	–	15	30	50	KHZ	

AZ Displays, Inc.

4. OPTICAL CHARACTERISTICS

4-1 Optical Char. of Normal Temp. Mode

AT V_{OP}

ITEM MODE		Cr(Contrast Ratio)		θ (Viewing Angle)		ϕ (Viewing Angle)	
		25°C		25°C		25°C	
		MIN.	TYP.	MIN.	TYP.	MIN.	TYP.
R	A, B	3.5	4.5	50	75	20	30
	C, D	6.0	9.0	60	85	20	35
	J	4.5	7.5	55	80	20	35
S	A, B	3.0	4.2	50	75	20	30
	C, D	5.0	8.0	55	85	20	35
	J	4.0	7.0	50	75	20	35
T	A	2.0	2.5	40	60	18	25
	E, F	3.0	4.0	50	70	20	35
	J, K	3.0	4.0	50	70	20	35
note		NOTE6		NOTE5			

AT $\phi=0^\circ$ $\theta=0^\circ$

ITEM	SYMBOL	CONDITION	MIN.	TYP.	MAX.	UNIT	NOTE
Response Time (rise)	Tr	0°C	—	600	1200	ms	NOTE 2
		25°C	—	110	220		
		50°C	—	50	100		
Response Time (fall)	Tf	0°C	—	900	1500	ms	NOTE 2
		25°C	—	250	360		
		50°C	—	100	150		

note:

R: REFLECTIVE
 S: TRANFLECTIVE
 T: TRANSMISSIVE
 A: GRAY
 C: YELLOW
 E: BLUE
 G: NORMALLY BLACK
 J: NORMALLY WHITE

AZ Displays, Inc.

4-2 Optical Char. of Wide Temp. Mode

AT V_{op}

ITEM MODE		Cr(Contrast Ratio)		θ (Viewing Angle)		ϕ (Viewing Angle)	
		25°C		25°C		25°C	
		MIN.	TYP.	MIN.	TYP.	MIN.	TYP.
R	A	3.5	4.2	50	68	20	30
	C	5.0	—	50	—	30	35
	J	6.0	8.0	50	70	20	38
S	A	3.5	4.0	50	65	20	30
	C	5.0	—	50	—	25	35
	J	5.0	7.0	50	—	25	35
T	E						
	G						
note		NOTE6		NOTE5			

AT $\phi=0^\circ$ $\theta=0^\circ$

ITEM	SYMBOL	CONDITION	MIN.	TYP.	MAX.	UNIT	NOTE
Response Time (rise)	Tr	-20°C	—	2100	3200	ms	NOTE 2
		0°C	—	450	680		
		25°C	—	150	250		
		50°C	—	110	170		
		70°C	—	70	90		
Response Time (fall)	Tf	-20°C	—	2100	3200	ms	NOTE 2
		0°C	—	400	600		
		25°C	—	120	180		
		50°C	—	60	100		
		70°C	—	30	50		

note:

R: REFLECTIVE
 S: TRANSFLECTIVE
 T: TRANSMISSIVE
 A: GRAY
 C: YELLOW
 E: BLUE
 G: NORMALLY BLACK
 J: NORMALLY WHITE

AZ Displays, Inc.

(NOTE 4)

Definition of Viewing Direction

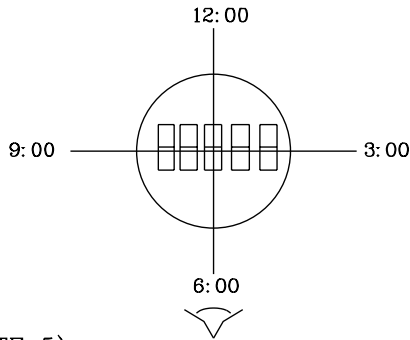

(NOTE 5)

Definition of Viewing Angle

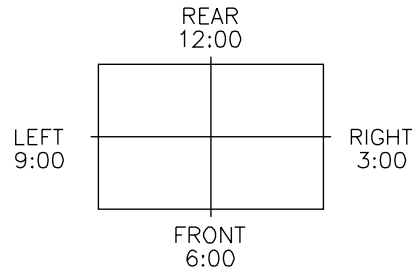
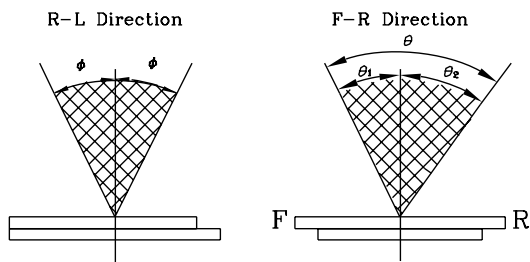

*For This Product

The Viewing Direction Is 6 O'clock
So $\theta_1 > \theta_2$

$$\theta = \theta_1 + \theta_2$$

*Conditions

Operating Voltage : V_{op}
Frame Frequency : 70Hz
Applying Waveform : 1/N duty 1/a bias
Contrast Ratio : larger than 2

(NOTE 6)

Definition of Contrast Ratio (Cr)

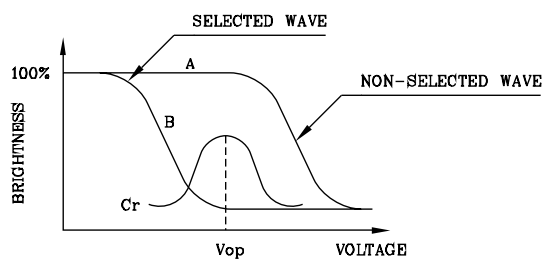

(positive type)

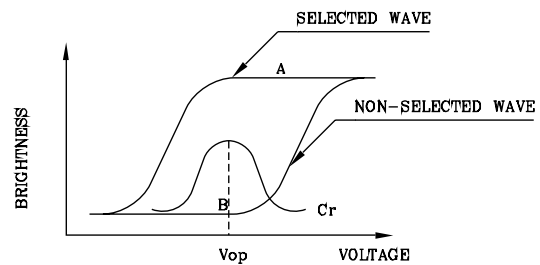

(negative type)

$$\text{Contrast Ratio : } Cr = A/B$$

*Conditions

Viewing Angle : 0
Frame Frequency : 70Hz
Applying Waveform : 1/N duty 1/a bias

AZ Displays, Inc.

5. BLOCK DIAGRAM

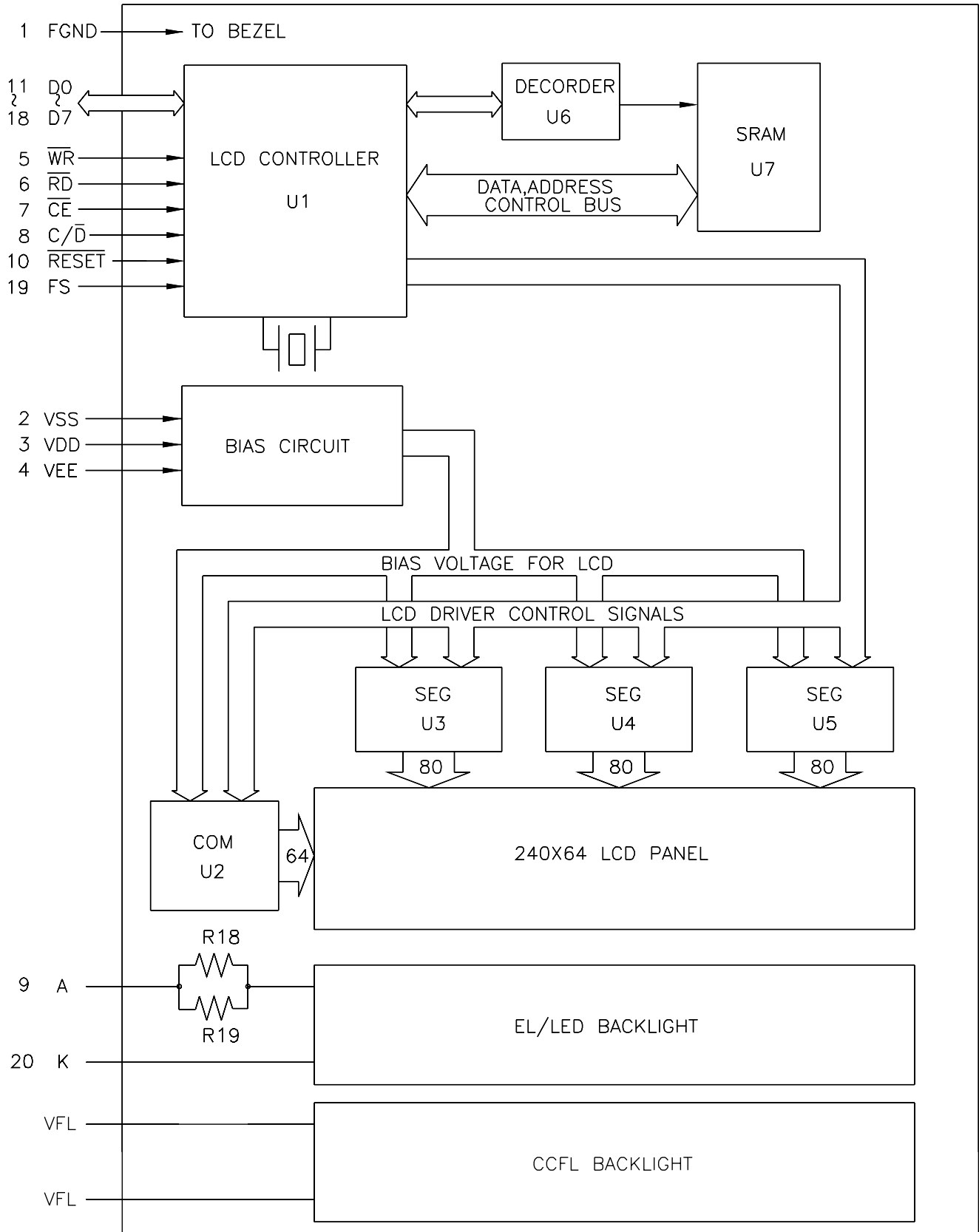

AZ Displays, Inc.

6. INTERNAL PIN CONNECTION

PIN NO.	SYMBOL	FUNCTION
1	FGND	FRAME GROUND (0V)
2	VSS	GROUND
3	VDD	POWER SUPPLY FOR LOGIC (+5V)
4	VEE	POWER SUPPLY FOR LC DRIVING
5	\overline{WR}	DATA WRITE
6	\overline{RD}	DATA READ
7	\overline{CE}	CHIP ENABLE
8	C/ \overline{D}	\overline{WR} ="L",C/ \overline{D} ="H" :COMMAND WRITE \overline{WR} ="L",C/ \overline{D} ="L" :DATA WRITE \overline{RD} ="L",C/ \overline{D} ="H" :STATUS READ \overline{RD} ="L".C/ \overline{D} ="L" :DATA READ
9	A	Anode of LED B/L and EL B/L
10	\overline{RESET}	CONTROLLER RESET
11	D0	DATA INPUT/OUTPUT
12	D1	DATA INPUT/OUTPUT
13	D2	DATA INPUT/OUTPUT
14	D3	DATA INPUT/OUTPUT
15	D4	DATA INPUT/OUTPUT
16	D5	DATA INPUT/OUTPUT
17	D6	DATA INPUT/OUTPUT
18	D7	DATA INPUT/OUTPUT
19	FS	FONT SELECT CONNECT TO VDD :6X8 PIXELS/CHARACTER CONNECT TO GND :8X8 PIXELS/CHARACTER
20	K	Cathode of LED B/L and EL B/L

CCFL Connector : J.A.E/IL-G-4S-S3C2

PIN NO	SYMBOL	FUNCTION
1	VFL	POWER SUUPLY FOR CCFL DRIVE
2	NC	-
3	NC	-
4	VFL	POWER SUUPLY FOR CCFL DRIVE

AZ Displays, Inc.

7. POWER SUPPLY

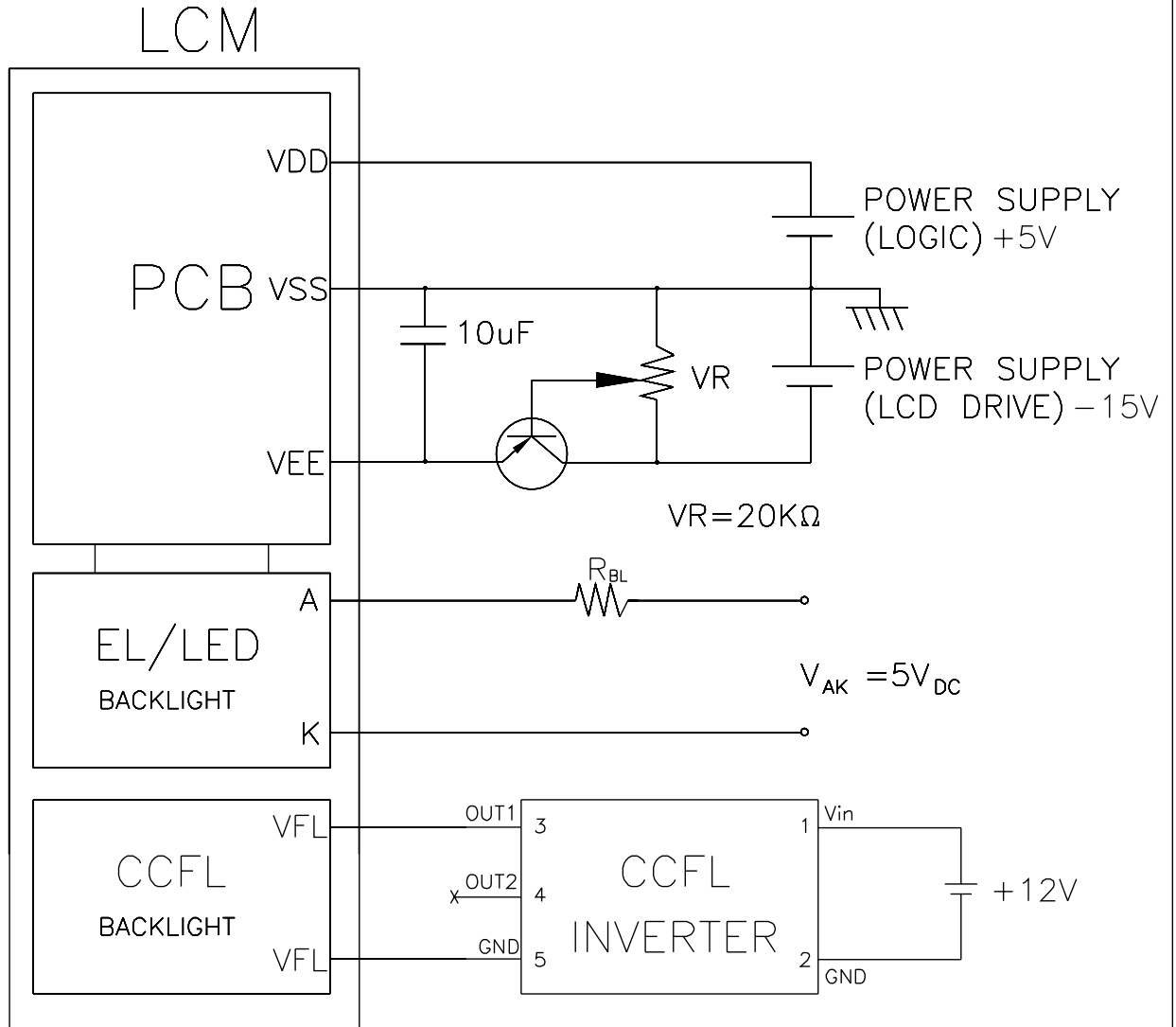

Recommended Inverter : CXA-L10L (TDK)

Recommended Value for R_{BL} and V_{BL}

item	R_{BL}		V_{BL}	
	EL	LED	EL	LED
Back Light interface	EL	LED	EL	LED
A,K PIN	0Ω	5Ω	110V _{AC} 400HZ	5V _{DC}

AZ Displays, Inc.

8. TIMING CHARACTERISTICS

8-1 INTERFACE TIMING

ITEM	ITEM	CONDITION	MIN.	MAX.	UNIT
C/ \bar{D} SET UP TIME	t_{CDS}	Fig.	100	-	ns
C/ \bar{D} HOLD TIME	t_{CDH}	Fig.	10	-	ns
$\bar{C}\bar{E}, \bar{R}\bar{D}, \bar{W}\bar{R}$ CLOCK WIDTH	t_{CP}, t_{RP}, t_{WP}	Fig.	80	-	ns
DATA SET UP TIME	t_{DS}	Fig.	80	-	ns
DATA HOLD TIME	t_{DH}	Fig.	40	-	ns
ACCESS TIME	t_{ACC}	Fig.	-	150	ns
DATA OUTPUT HOLD TIME	t_{OH}	Fig.	10	50	ns

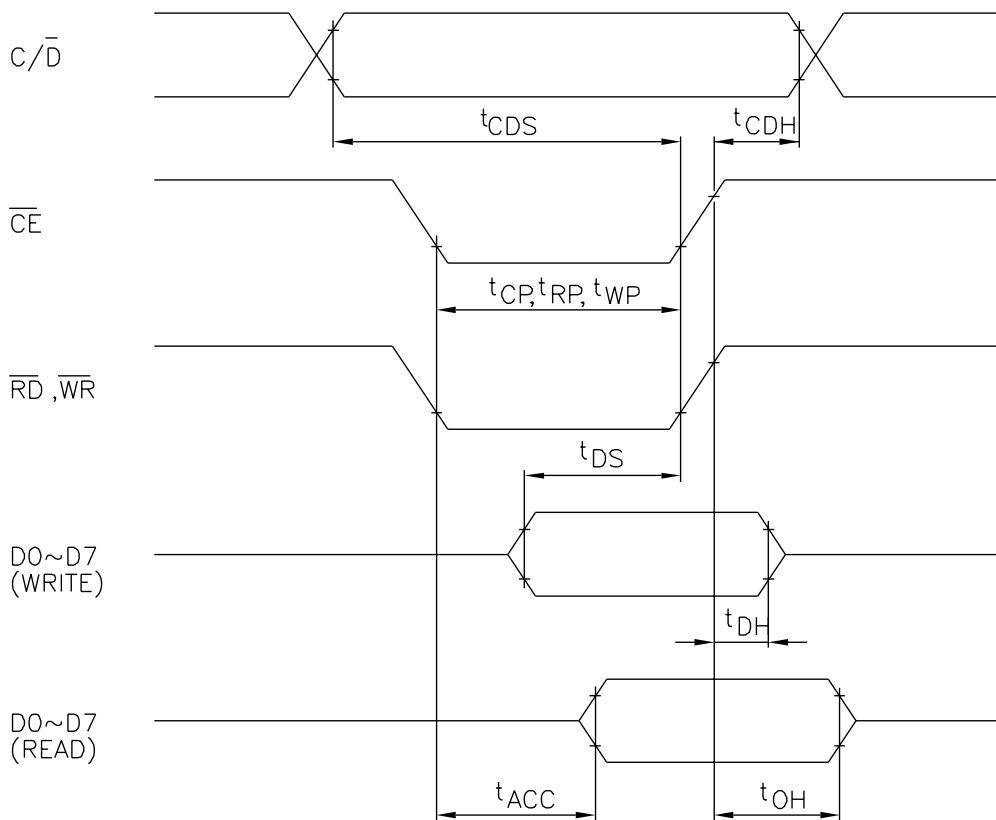
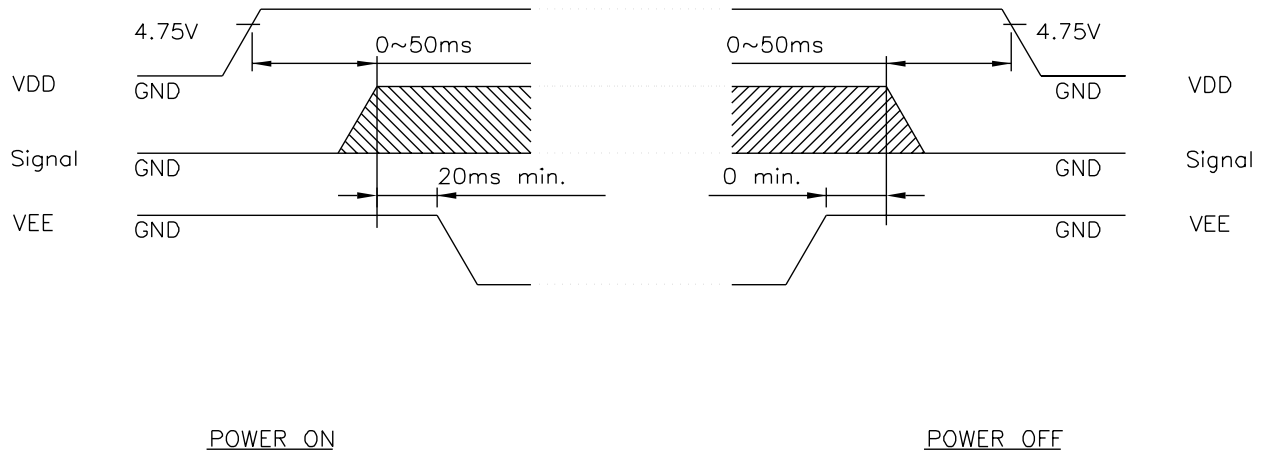

Fig. INTERFACE TIMING CHART

AZ Displays, Inc.

8-2 POWER ON/OFF TIMING



The missing pixels may occur when the LCM is driven beyond above power interface timing sequence.

AZ Displays, Inc.

8-3 DISPLAY PATTERN

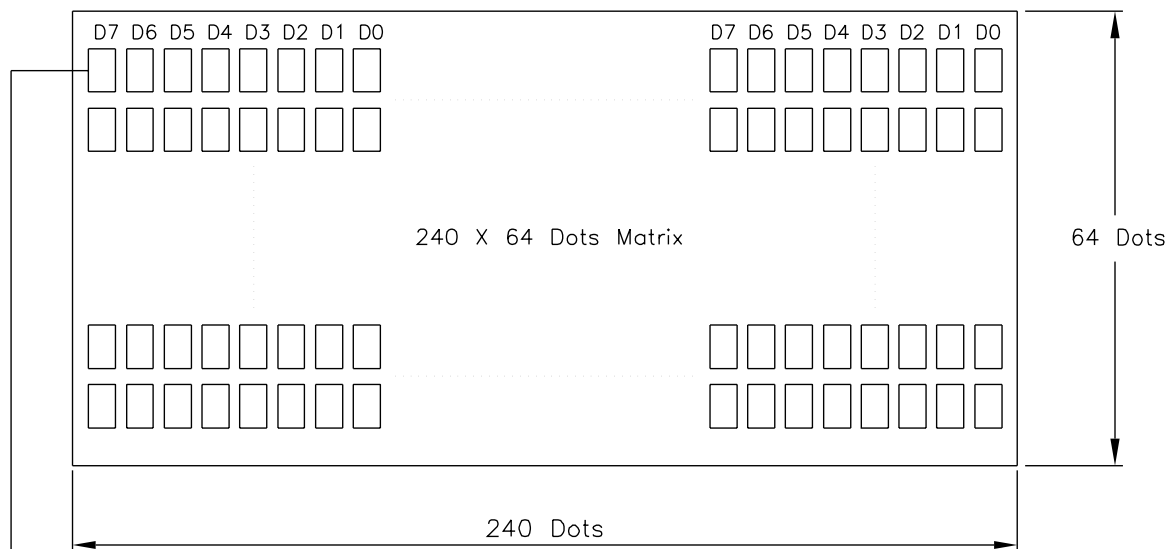

Starting dot for the starting address of display RAM D0~D7,
where D0 is LSB and D7 is MSB.

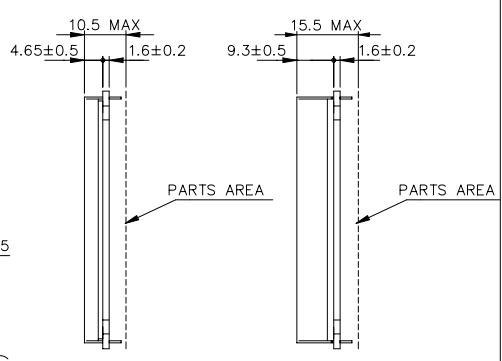
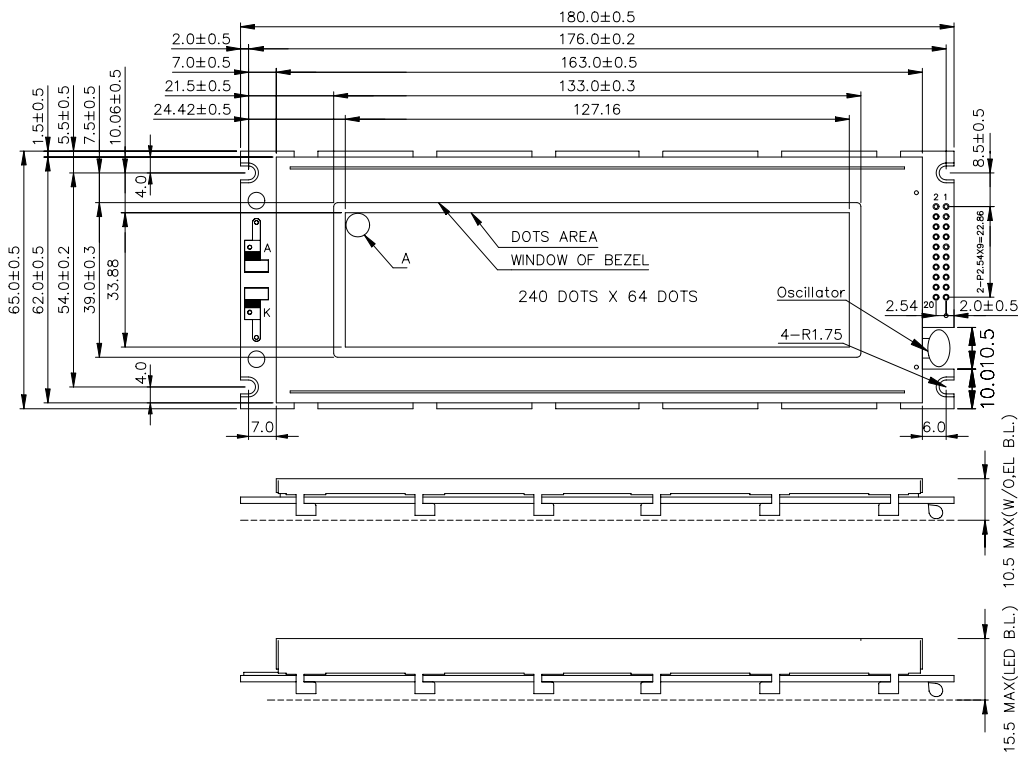

W/O, EL B/L LED B/L

- NOTES:
1. Resolution : 240 x 64 Dots
 2. Controller : T6963C
 3. DC/DC Converter : Without
 4. General Tolerance : ±0.5 mm

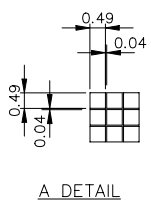

PIN NO.	1	2	3	4	5	6	7	8	9	10
SYMBOL	FGND	VSS	VDD	VEE	WR	RD	CE	C/D	A	RESET

PIN NO.	11	12	13	14	15	16	17	18	19	20
SYMBOL	D0	D1	D2	D3	D4	D5	D6	D7	FS	K

AGM2464D			AZ DISPLAYS, INC.		
APPROVE	NAME	DATE	TITLE		
CHECK			DWG-NO	MX-X003XP	Rev.B
DESIGN	M.Y. Lin	88.10.8		UNIT	mm
DRAW	MAY PING	88.10.8		SCALE	NTS

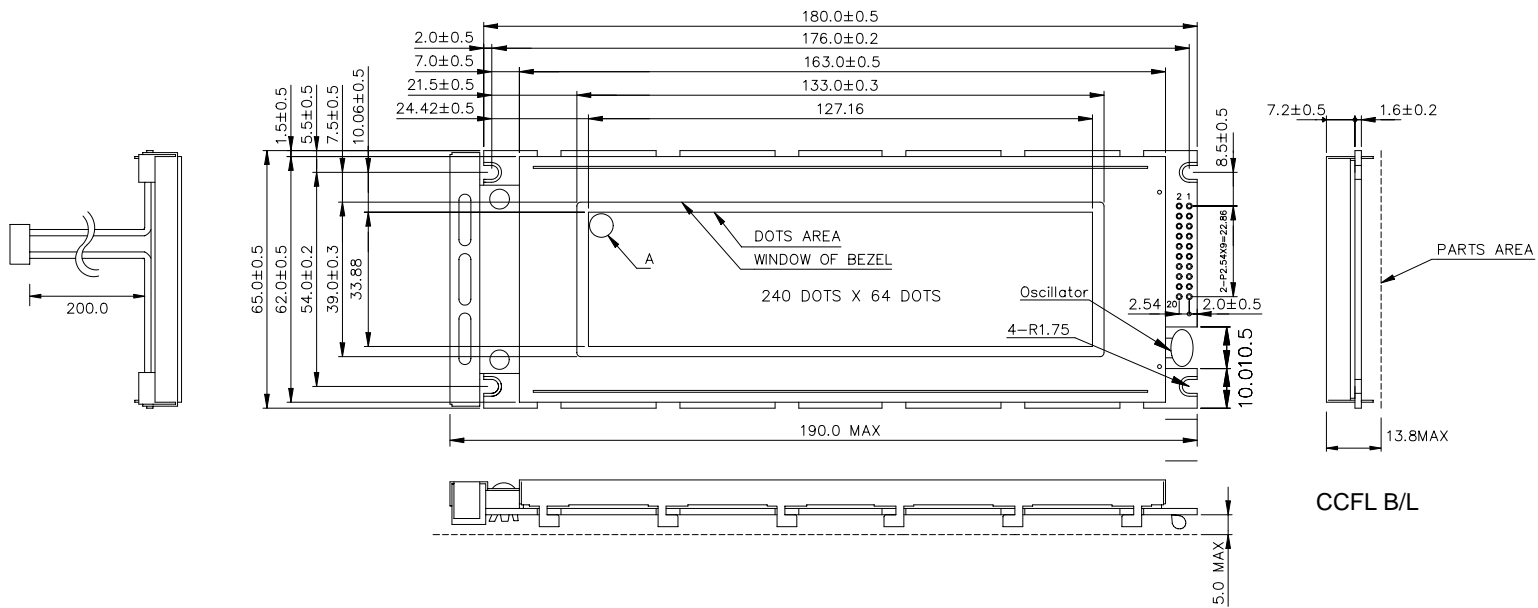

CCFL B/L

NOTES:

- Resolution : 240 x 64 Dots
- Controller : T6963C
- DC/DC Converter : Without
- General Tolerance : ±0.5 mm

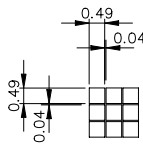

A DETAIL

PIN NO.	1	2	3	4	5	6	7	8	9	10
SYMBOL	FGND	VSS	VDD	VEE	WR	RD	CE	C/D	A	RESET
PIN NO.	11	12	13	14	15	16	17	18	19	20
SYMBOL	D0	D1	D2	D3	D4	D5	D6	D7	FS	K

AGM2464D			AZ DISPLAYS, INC.		
APPROVE	NAME	DATE	TITLE		
CHECK			DWG-NO	MB-X003X1P	Rev.B
DESIGN	M.Y. Lin	88.10.8	UNIT	mm	
DRAW	MAY PING	88.10.8	SCALE	NTS	

