

AZ DISPLAYS, INC.

1. MECHANICAL DATA

(1) Product No.	AGM3224D
(2) Module Size	167.1 (W)mm x 109.0 (H)mm x MAX 11.0 (D)mm (CCFT B.L.)
(3) Dot Size	0.33 (W)mm x 0.33 (H)mm
(4) Dot Pitch	0.36 (W)mm x 0.36 (H)mm
(5) Number of Dots	320 (W) x 240 (H)Dots
(6) Duty	1/240
(7) LCD Display Mode	STN: <input type="checkbox"/> Gray Mode <input type="checkbox"/> Yellow Mode <input type="checkbox"/> Blue Mode FSTN: <input type="checkbox"/> Black and White(Normal White/Positive Image) <input type="checkbox"/> Black and White(Normal Black/Negative Image) Rear Polarizer: <input type="checkbox"/> Reflective <input type="checkbox"/> Transflective <input type="checkbox"/> Transmissive <input type="checkbox"/> Transflective(High Transmissive)
(8) Viewing Direction	<input type="checkbox"/> 6 O'clock <input type="checkbox"/> 12 O'clock <input type="checkbox"/> ____O'clock
(9) Backlight	<input type="checkbox"/> W/O <input type="checkbox"/> CCFT
(10) Recommended FL Inverter	TDK CORP. CXA-L10L
(11) Weight	CCFT : about 205 g

Revised: January 25, 2002

2. ABSOLUTE MAXIMUM RATINGS

(1) ELECTRICAL ABSOLUTE RATINGS

VSS=0V STANDARD

ITEM	SYMBOL	MIN	MAX	UNIT	COMMENT
Power Supply for Logic	VDD-VSS	-0.3	7.0	V	
Power Supply for LCM	VDD-VEE	0	30.0	V	
Input Voltage	VI	-0.3	VDD	V	
CCFL Driving Voltage	VFL	0	500	Vrms	
CCFL Input Current	IFL	-	7.0	mArms	
Static Electricity	-	-	-	-	Note 1

Note 1 LCM should be grounded during handling

(2) ENVIRONMENTAL ABSOLUTE MAXIMUM RATINGS

ITEM	OPERATING		STORAGE	
	MIN.	MAX.	MIN.	MAX.
Ambient Temperature	-20	70	-30	80
Humidity (Without Condensation)	Note 1,3		Note 2,3	

Note 1 $T_a \leq 70^\circ\text{C}$: 75%RH max

$T_a > 70^\circ\text{C}$: Absolute humidity must be lower than the humidity of 75%RH at 70°C

Note 2 T_a at -30°C will be $< 48\text{hrs}$, at 80°C will be $< 120\text{hrs}$

Note 3 Background color changes slightly depending on ambient temperature. This phenomenon is reversible.

(FIG 1)

Definition of Operation Voltage(Vop)

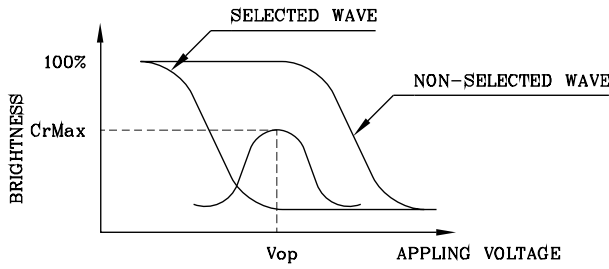

(positive type)

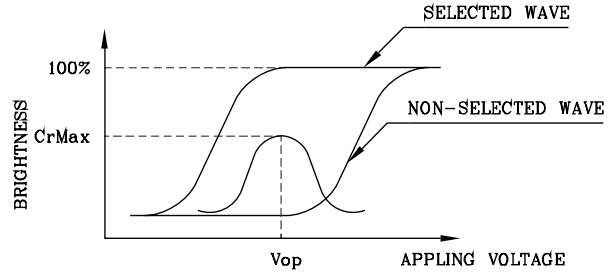

(negative type)

*Conditions

Viewing Angle : 0
 Frame Frequency : 70Hz
 Applying Waveform : 1/N duty 1/a bias

(FIG 2)

Definition of Response Time(Tr,Tf)

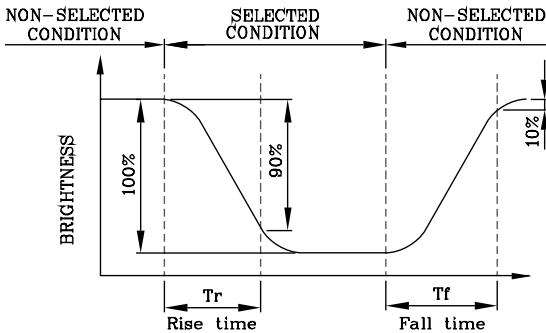

(positive type)

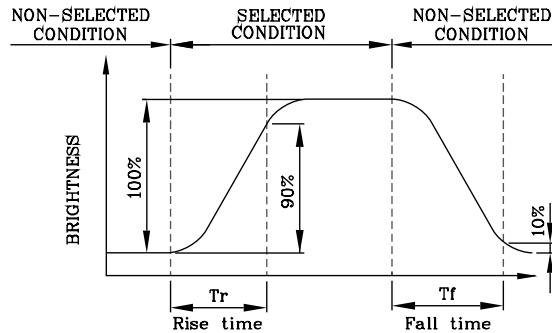

(negative type)

*Conditions

Operating Voltage : Vop
 Viewing Angle (θ,φ) : (0,0)
 Frame Frequency : 70Hz
 Applying Waveform : 1/N duty 1/a bias

(FIG 3)

Description of Measuring Equipment and Driving Waveforms

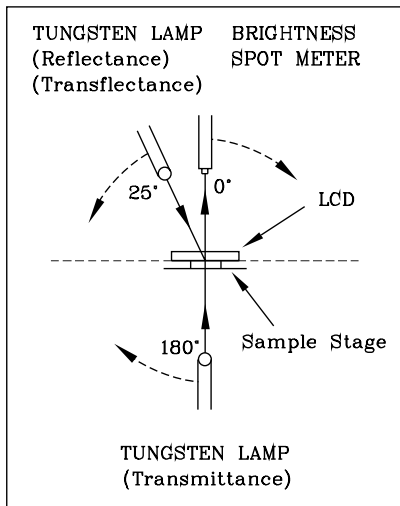

CONST.
TEMP.
CHAMBER

Multiplex Driving (1/N duty 1/a bias)

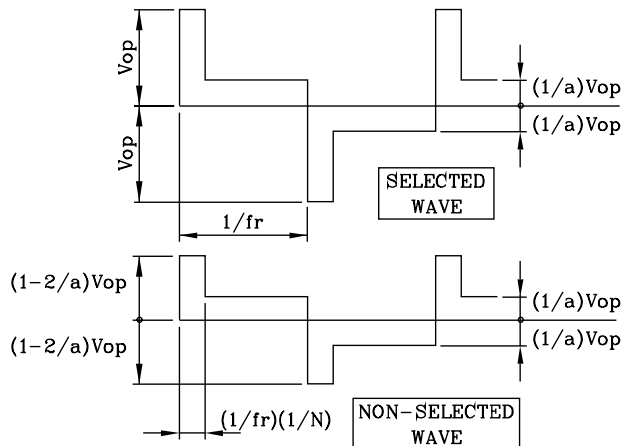

(NOTE 4)

Definition of Viewing Direction

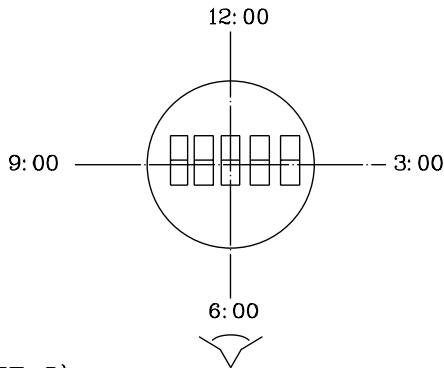

(NOTE 5)

Definition of Viewing Angle

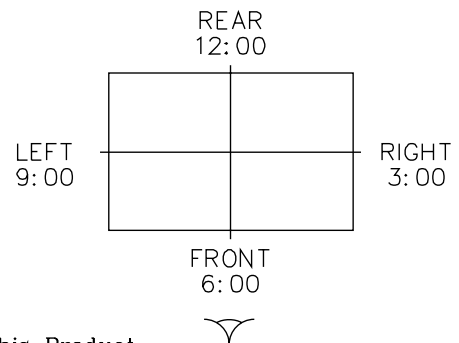
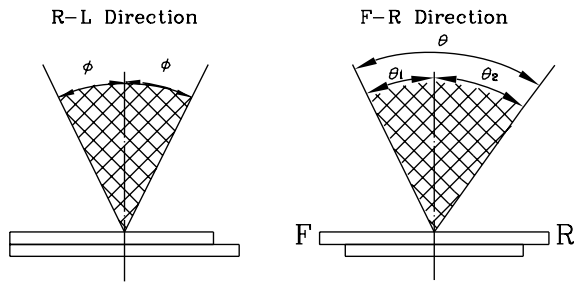

*For This Product
The Viewing Direction Is 6 O'clock
So $\theta_1 > \theta_2$

$$\theta = \theta_1 + \theta_2$$

*Conditions

Operating Voltage : V_{op}
Frame Frequency : 70Hz
Applying Waveform : 1/N duty 1/a bias
Contrast Ratio : larger than 2

(NOTE 6)

Definition of Contrast Ratio (Cr)

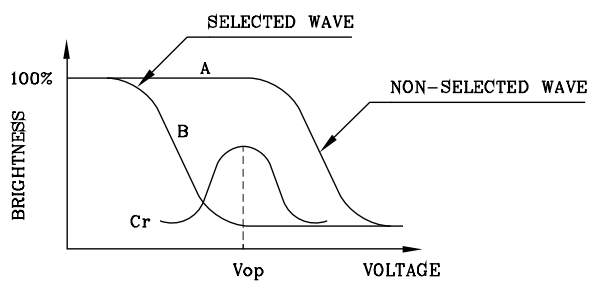

(positive type)

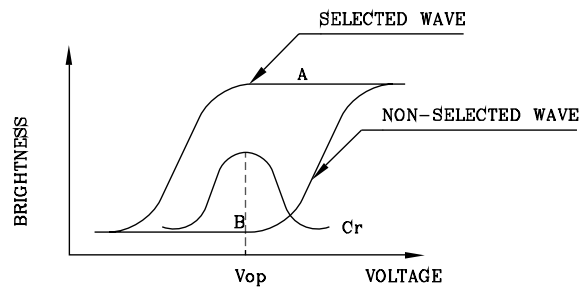

(negative type)

$$\text{Contrast Ratio : } Cr = A/B$$

*Conditions

Viewing Angle : 0
Frame Frequency : 70Hz
Applying Waveform : 1/N duty 1/a bias

3. ELECTRICAL CHARACTERISTICS

(VDD = 5V±5%)

ITEM	SYMBOL	CONDITION	MIN.	TYP.	MAX.	UNIT	
Power Supply for Logic	VDD-VSS	-	4.75	5.0	5.25	V	
Recommended LC Driving Voltage	VDD-VO	Duty=1/240 Bias=1/13	-20°C	-	24.1	25.0	V
			0°C	-	22.7	23.6	
			25°C	21.3	22.0	22.8	
			50°C	20.3	20.8	-	
			70°C	20.1	20.9	-	
Input Voltage	VIH	H level	0.8VDD	-	VDD	V	
	VIL	L level	0	-	0.2VDD	V	
Power Supply Current	IDD	FLM = 70 Hz VDD = 5.0 V VEE = -24.0 V VDD-VO = 22.0 V	-	7.7	-	mA	
	IEE	PATTERN : <div style="display: flex; justify-content: space-around; font-family: monospace; font-size: 0.8em;"> □ ■ □ ■ □ ■ </div> <div style="display: flex; justify-content: space-around; font-family: monospace; font-size: 0.8em;"> ■ □ ■ □ ■ □ </div>	-	3.9	-	mA	
CCFL LAMP	Open Voltage	V _{Open}	Lamp Current = 5 mArms Frequency = 35 KHz	-	420	-	V _{rms}
	Lamp Voltage	V _L		-	260	-	V _{rms}
	Brightness	B		-	26000	-	cd/m ²
	Color Degree	X		-	0.34	-	-
		Y		-	0.367	-	

4. OPTICAL CHARACTERISTICS

AT V_{OP}

ITEM MODE		Cr(Contrast Ratio)										θ (Viewing Angle)		ϕ (Viewing Angle)	
		-20℃		0℃		25℃		50℃		70℃		25℃		25℃	
		MIN.	TYP.	MIN.	TYP.	MIN.	TYP.	MIN.	TYP.	MIN.	TYP.	MIN.	TYP.	MIN.	TYP.
R	A	-	-	-	-	-	-	-	-	-	-	-	-	-	-
	C	-	-	-	-	-	-	-	-	-	-	-	-	-	-
	J	-	-	-	-	-	-	-	-	-	-	-	-	-	-
S	A	-	-	-	-	-	-	-	-	-	-	-	-	-	-
	C	-	-	-	-	-	-	-	-	-	-	-	-	-	-
	J	-	-	-	-	-	-	-	-	-	-	-	-	-	-
T	E,F	-	3.8	-	6.4	9.2	10.8	-	8.5	-	7.3	35	65	20	30
	G,H	-	20.7	-	30.4	48	56	-	13.5	-	9.21	40	70	25	35
note		NOTE6										NOTE5			

AT $\phi=0^\circ$ $\theta=0^\circ$

ITEM	SYMBOL	CONDITION	MIN.	TYP.	MAX.	UNIT	NOTE
Response Time (rise)	Tr	-20℃	-	1000	2000	ms	NOTE 2
		0℃	-	820	1640		
		25℃	-	200	400		
		50℃	-	160	320		
		70℃	-	80	160		
Response Time (fall)	Tf	-20℃	-	500	1000	ms	NOTE 2
		0℃	-	360	720		
		25℃	-	210	420		
		50℃	-	70	140		
		70℃	-	50	100		

note:

R: REFLECTIVE
 S: TRANSFLECTIVE
 T: TRANSMISSIVE
 A: GRAY

C: YELLOW
 E,F: BLUE
 G,H: NORMALLY BLACK
 J: NORMALLY WHITE

5. BLOCK DIAGRAM

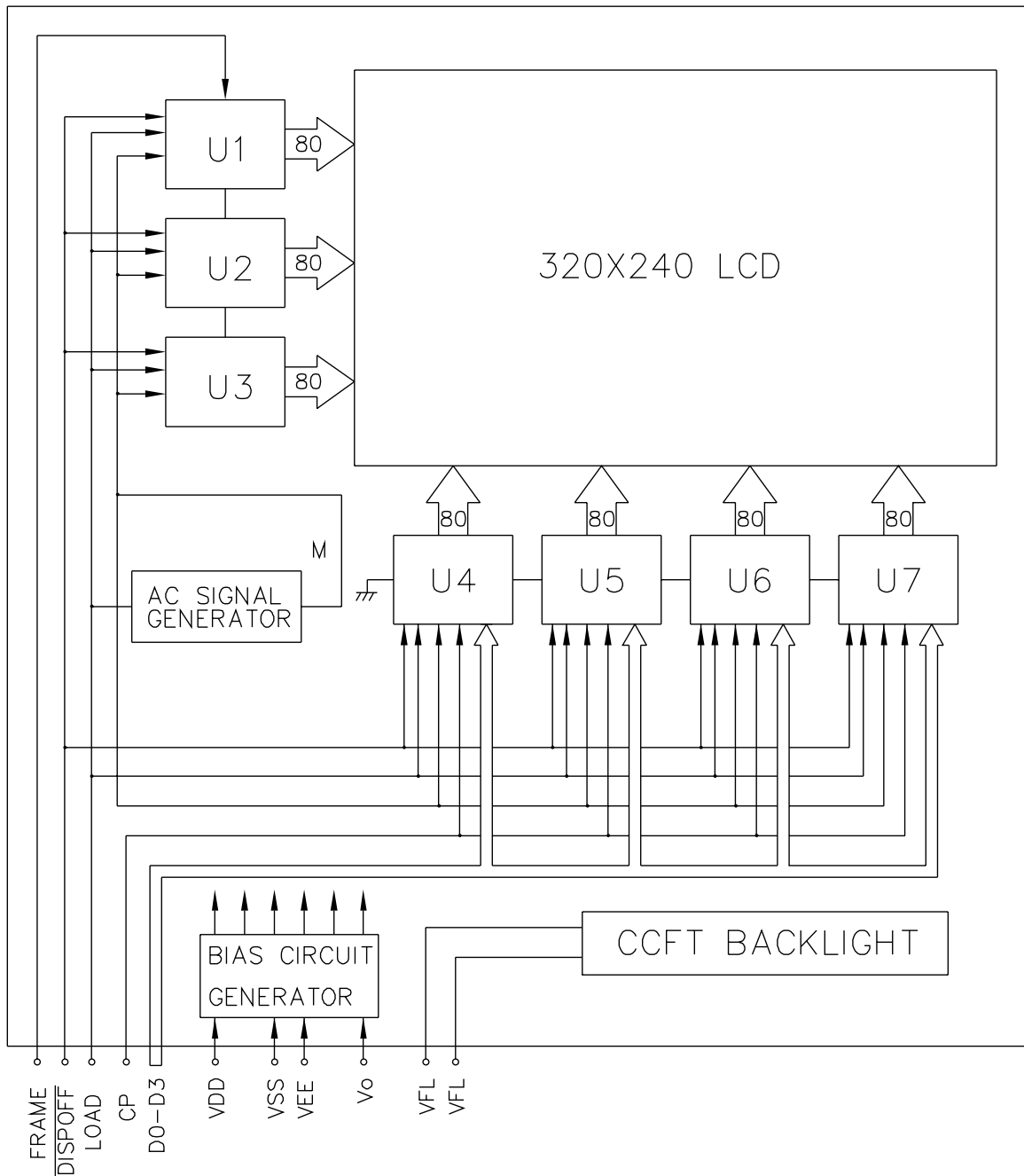

* AC SIGNAL SETTING

J1	J2	J3	J4	J5	J6	J7	J8
L	H	H	L	L	L	L	L

6. INTERNAL PIN CONNECTION

PIN NO.	SYMBOL	LEVEL	FUNCTION
1	D0	H/L	DISPLAY DATA SIGNAL
2	D1		
3	D2		
4	D3		
5	$\overline{\text{DISPOFF}}$	H/L	H: ON/L: OFF
6	FRAME	H	SCAN START-UP SIGNAL
7	NC	-	NO CONNECTION
8	LOAD	H→L	INPUT DATA LATCH SIGNAL
9	CP	H→L	DATA INPUT CLOCK SIGNAL
10	VDD	-	POWER SUPPLY FOR LOGIC(+5V)
11	VSS	-	SIGNAL GROUND(0V)
12	VEE	-	POWER SUPPLY FOR LCD
13	VO	-	LCD CONTRAST ADJUST VOLTAGE
14	FGND	-	FRONT PANEL GROUND

CCFL CONNECTOR : J.A.E./IL-G-4S-S3C2

PIN NO.	SYMBOL	LEVEL	FUNCTION
1	V _{FL}	-	POWER SUPPLY FOR CCFT BACKLIGHT
2	NC	-	-
3	NC	-	-
4	V _{FL}	-	POWER SUPPLY FOR CCFT BACKLIGHT

7. POWER SUPPLY

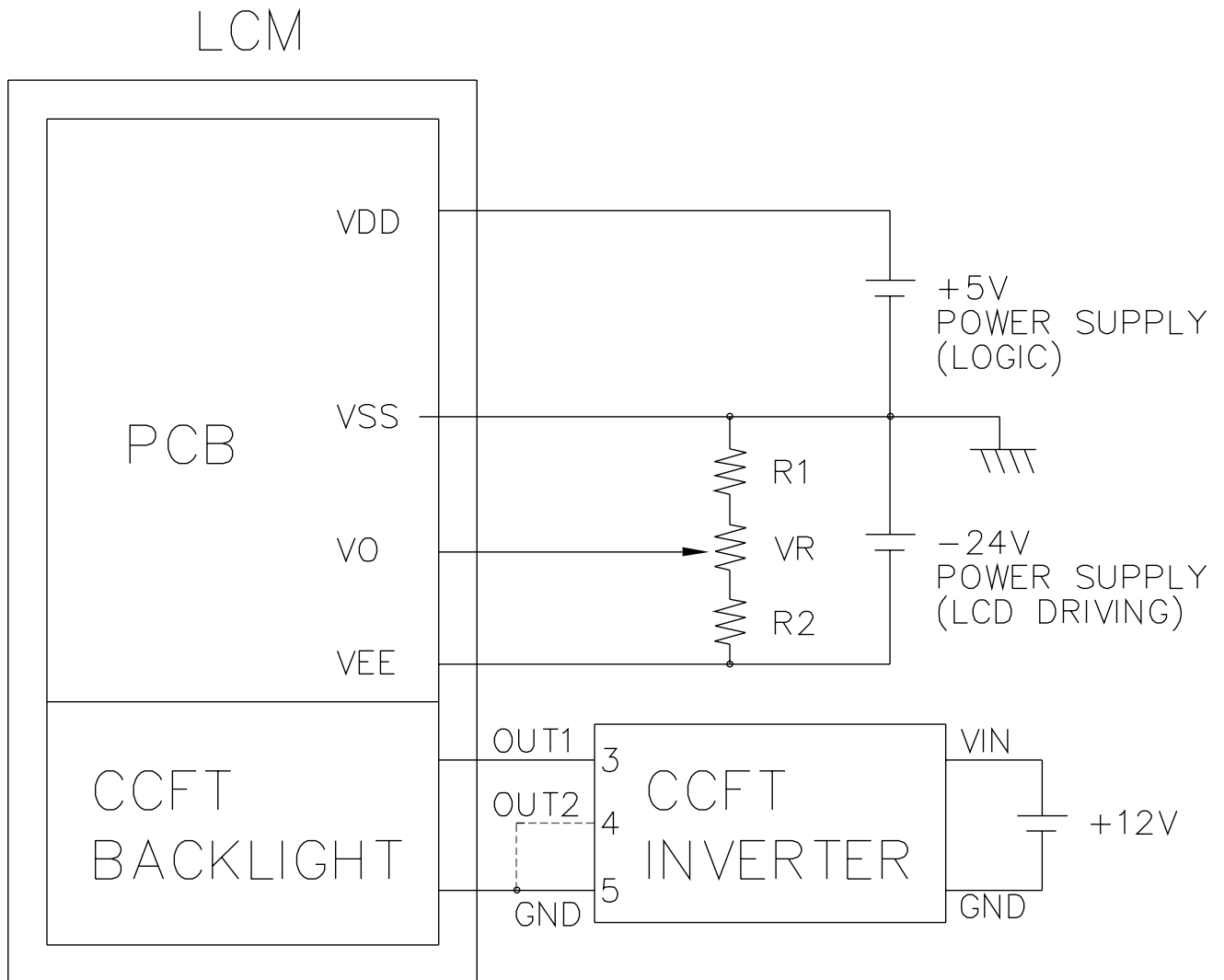

1. $R1 + VR + R2 = 10K \sim 20K \Omega$

2. RECOMMENDED CCFT INVERTER : CXA-L10L(TDK)

8.1 TIMING CHARACTERISTICS

ITEM	SYMBOL	MIN.	TYP.	MAX.	UNIT
CLOCK FREQUENCY	f_{cp}	—	—	6.5	MHZ
CLOCK PULSE WIDTH	t_w	63	—	—	ns
CLOCK RISE,FALL TIME	t_r, t_f	—	—	20	ns
DATA SET UP TIME	t_{dsu}	50	—	—	ns
DATA HOLD TIME	t_{dhd}	50	—	—	ns
LOAD SET UP TIME	t_{lsu}	80	—	—	ns
LOAD → CLOCK TIME	t_{lc}	80	—	—	ns
"FRAME" SET UP TIME	t_{SETUP}	100	—	—	ns
"FRAME" HOLD TIME	t_{HOLD}	100	—	—	ns
"LOAD" PULSE WIDTH	t_{wc}	125	—	—	ns

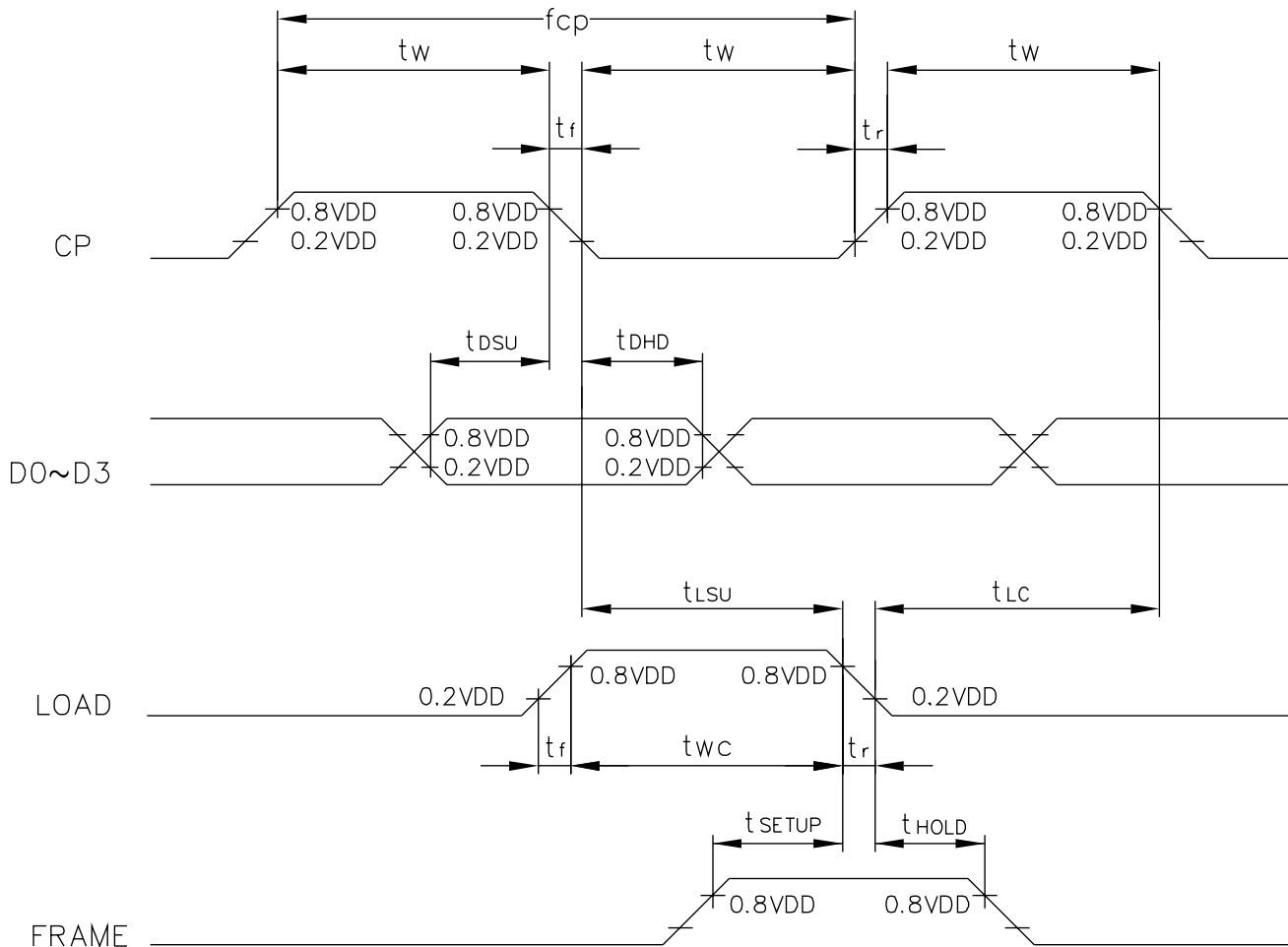

8.2 TIMING CHART OF INPUT SIGNALS

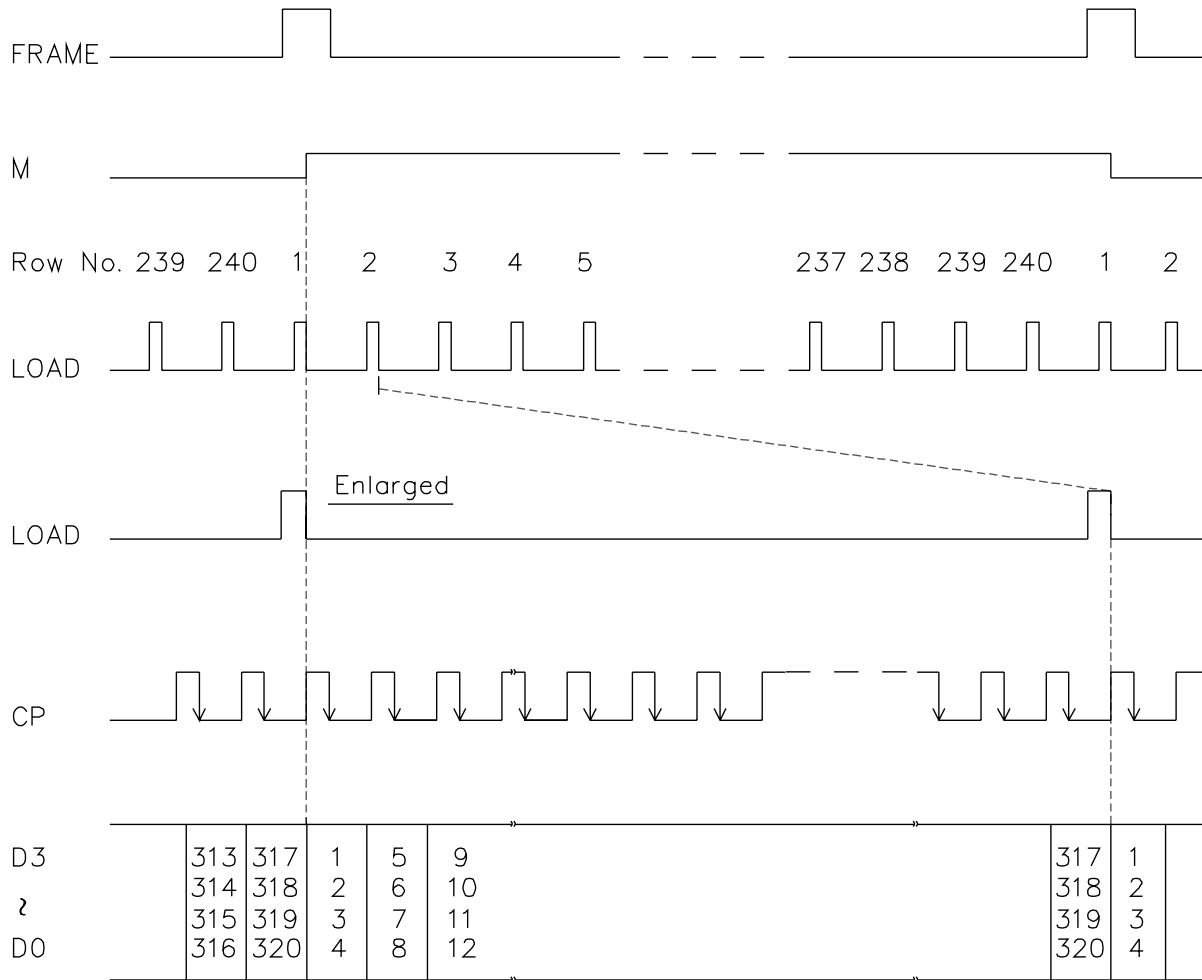

8.3 DISPLAY PATTERN

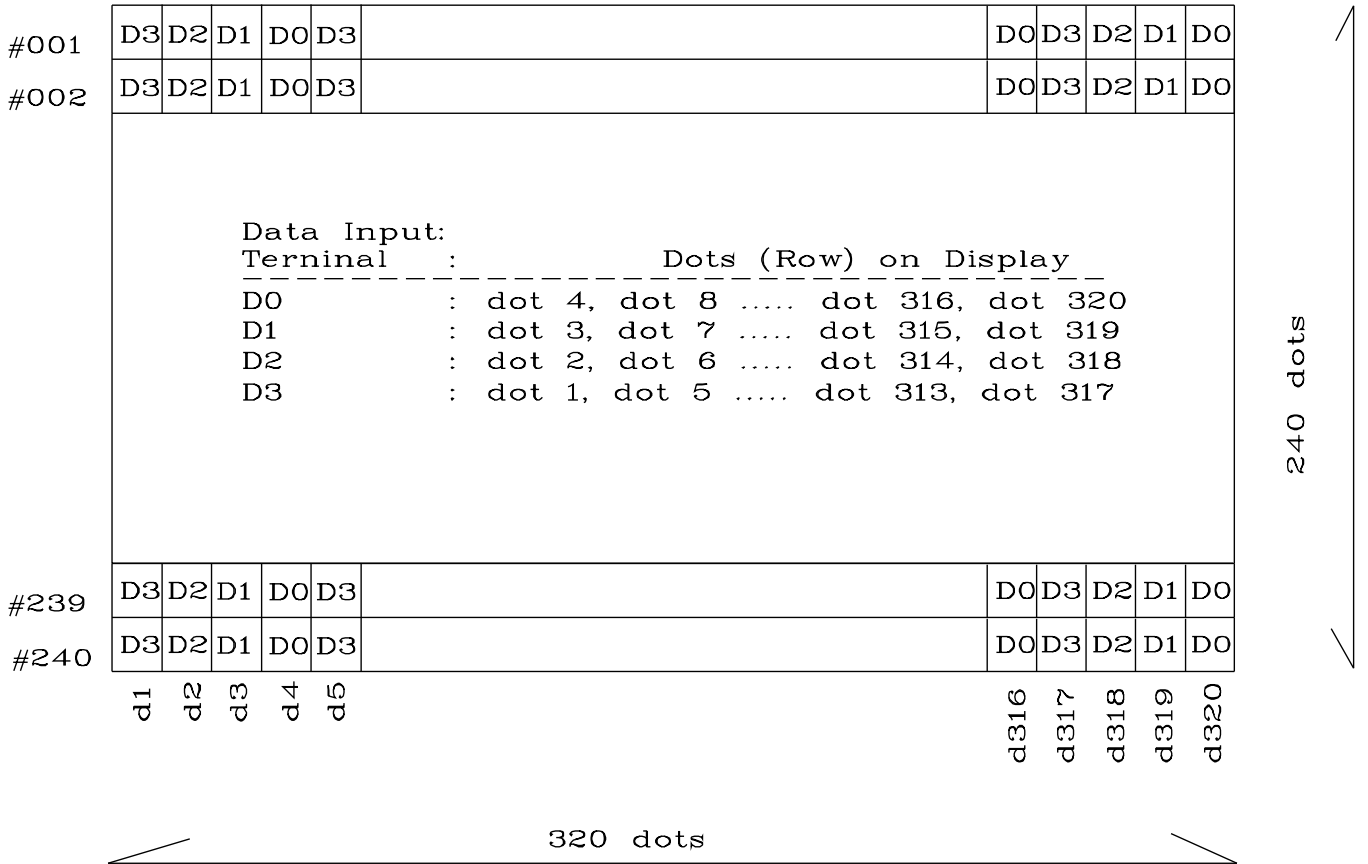

8.4 POWER ON/OFF TIMING

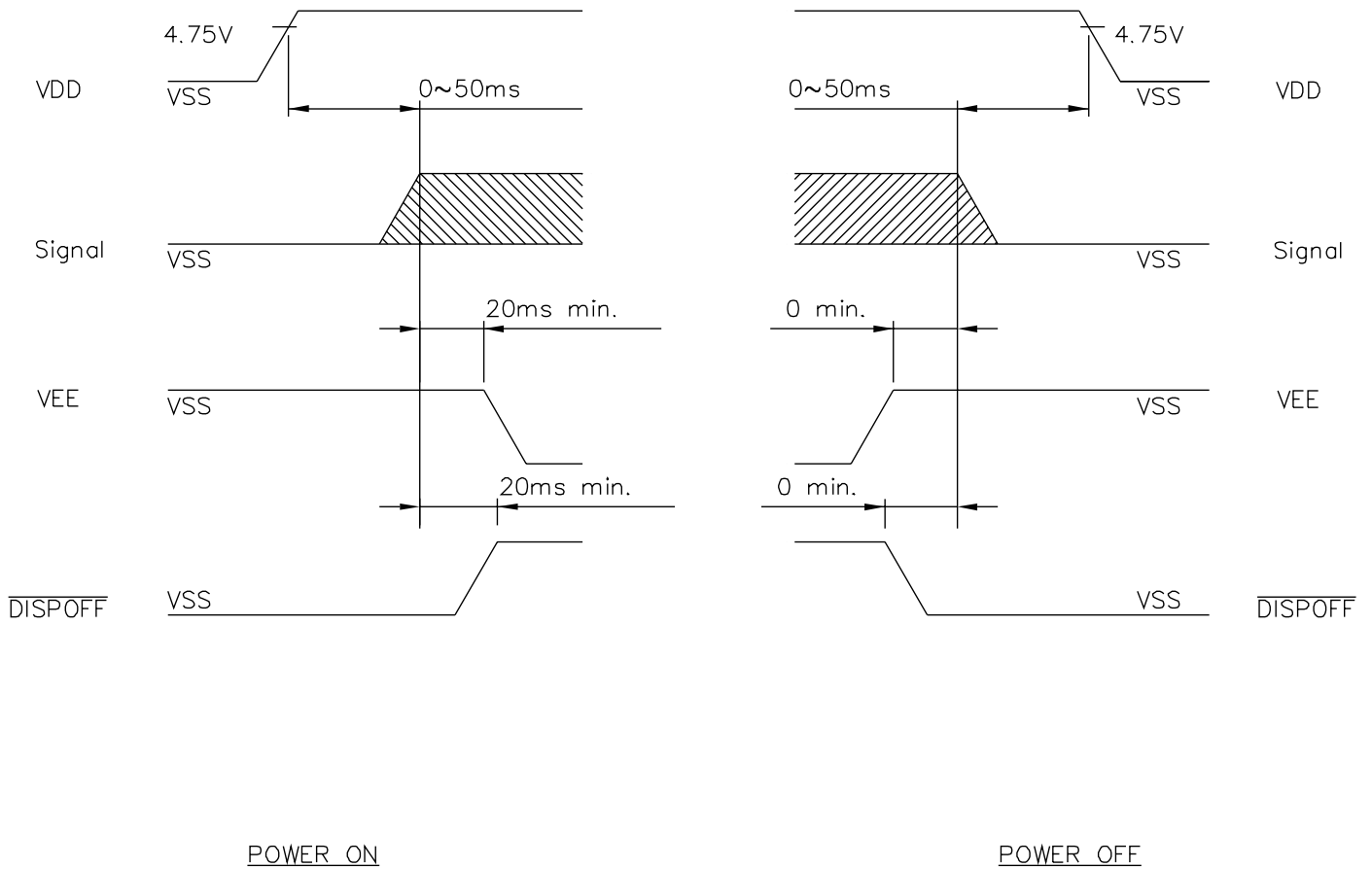

Missing pixels may occur when the LCM is driven beyond the above power interface timing sequence.

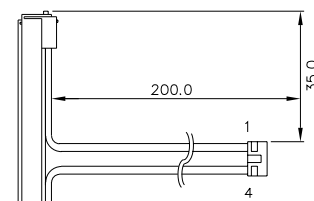
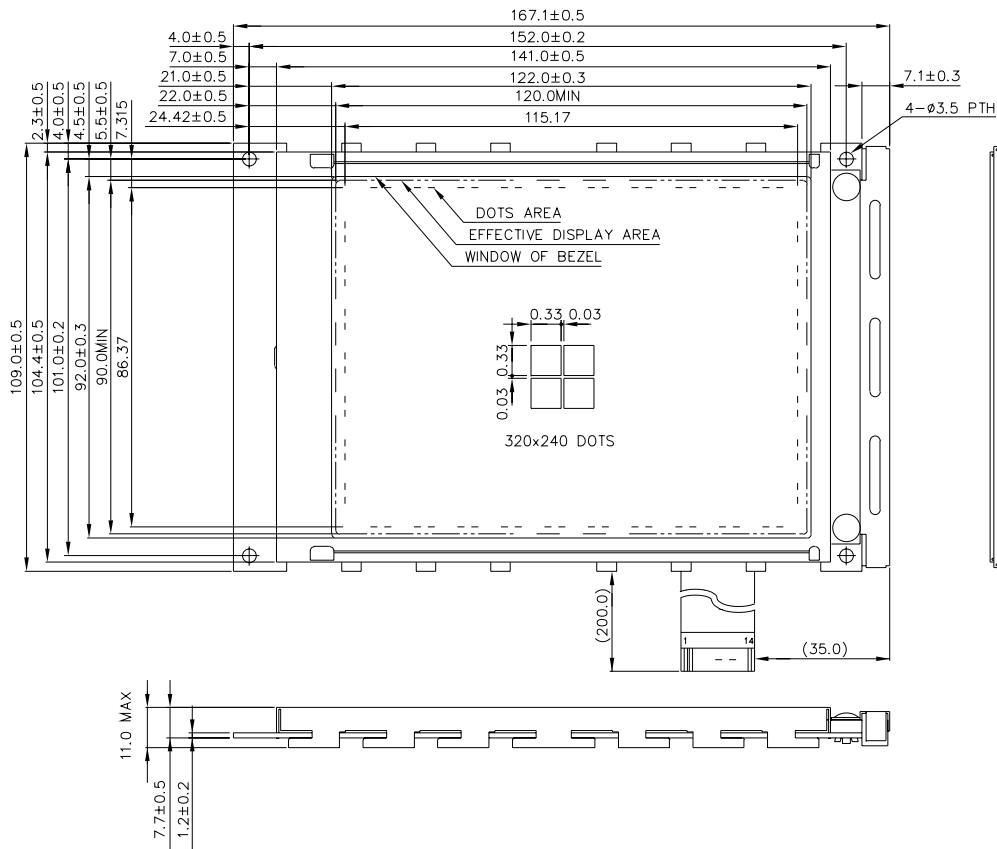

FL CONNECTER : J.A.E./IL-G-4S-S3C2

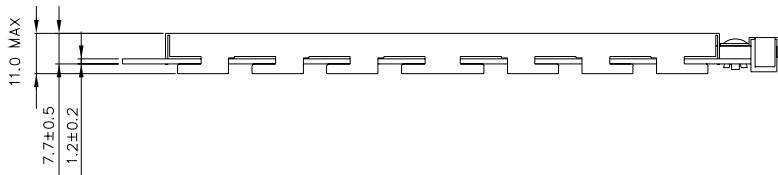
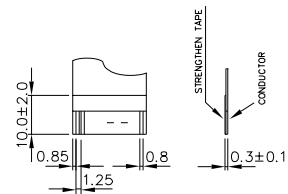

PIN NO.	1	2	3	4	5	6	7
SYMBOL	DO	D1	D2	D3	DISPOFF	FRAME	NC
PIN NO.	8	9	10	11	12	13	14
SYMBOL	LOAD	CP	VDD	VSS	VEE	VO	FGND

- NOTES :
- 1.RESOLUTION : 320 X 240 Dots
 - 2.CONTROLLER : WITHOUT
 - 3.DC/DC : WITHOUT
 - 4.BACKLIGHT:CCFL

			AZ DISPLAYS, INC.	
APPROVE	NAME	DATE	TITLE	AGM3224D
CHECK			DWG-NO	MB-X032XK
DESIGN			 THIRD ANGLE PROJECT	UNIT : mm
DRAW	MAY PING	86.10.29		SCALE : 1/1