

AZ DISPLAYS, INC.

1. MECHANICAL DATA

(1) Product No.	AGM3224V			
(2) Module Size	70.7 (W)mm X	90.2 (H)mm X	7.6 (D)mm	
(3) Dot Size	0.061 (W)mm X	0.215 (H)mm		
(4) Dot Pitch	0.076 (W)mm X	0.23 (H)mm		
(5) Number of Dots	240RGB(W)	X	320 (H) Dots	
(6) Duty	1/320			
(7) LCD Display Mode	FSTN: Color STN Module			
	Rear Polarizer: Color Transmissive Type			
(8) Viewing Direction	6 O'clock			
(9) Backlight	CCFL			
(10) Touch Panel	Included			
(11) Weight	70.3g (Approx.)			

Date: June 22,2002

2. ABSOLUTE MAXIMUM RATINGS

(1) ELECTRICAL ABSOLUTE RATINGS

GND=0V

ITEM	SYMBOL	MIN	MAX	UNIT	COMMENT
Power Supply for Logic	VDD-VSS	-0.3	7.0	V	
Power Supply for LC Drive	VEE-VSS	-0.3	36.0	V	
Input Voltage	VI	-0.3	VDD+0.3	V	
Static Electricity	-	-	-	-	Note 1

(2) ENVIRONMENTAL ABSOLUTE MAXIMUM RATINGS

ITEM	NORMAL TEMP.			
	OPERATING		STORAGE	
	MIN.	MAX.	MIN.	MAX.
Ambient Temperature	0	50	-20	70
Humidity (Without Condensation)	Note 2,3		Note 2,4	

Note 1 LCM should be grounded during handling

Note 2 Background color will change slightly depending on ambient temperature.
This phenomenon is reversible.

Note 3 $T_a \leq 50^\circ\text{C}$: 85%RH max
 $T_a > 50^\circ\text{C}$: Absolute humidity must be lower
than the humidity of 85%RH at 50°C

Note 4 T_a at -20°C will be < 48hrs, at 70°C will be < 120hrs

3-1. ELECTRICAL CHARACTERISTICS

ITEM		SYMBOL	CONDITION	MIN.	TYP.	MAX.	UNIT	
Logic Circuit Power Supply		VDD-VSS	Ta= 25°C	3.0	3.3	3.6	V	
Input Voltage		VIH	H level	0.8VDD	-	VDD	V	
		VIL	L level	0	-	0.2VDD		
Recommended LCD Driving Voltage		VEE-VSS (Vop)	Duty=1/320 Bias=1/17	0°C	30.3	30.6	30.9	V
				25°C	30.1	30.4	30.7	
				50°C	29.7	30.0	30.3	
Power Supply Current		IDD	VDD-VSS = 3.3V VEE-VSS = 30.4V Ta= 25°C PATTERN: □ ■ □ ■ □ ■ □ ■ ■ □ ■ □ ■ □ ■ □	-	0.56	1.0	mA	
		IEE		-	0.53	1.0		
LCM	Surface Luminance	L	INVERTER INV-081 Vin=10.3V IL=1.5mArms	PATTERN: (Dots All On of White Color) □ □ □ □ □ □ □ □	-	80.5	-	cd/m ²
				PATTERN: (Dots All Off) ■ ■ ■ ■ ■ ■ ■ ■	-	5.0	-	
			INVERTER INV-081 Vin=8.6V IL=1.0mArms	PATTERN: (Dots All On of White Color) □ □ □ □ □ □ □ □	-	45.2	-	
				PATTERN: (Dots All Off) ■ ■ ■ ■ ■ ■ ■ ■	-	2.9	-	

3-2.ELECTRICAL CHARACTERISTICS OF BACKLIGHT

CCFL Rating

Temp.=25°C

ITEM	SYMBOL	MIN.	TYP.	MAX.	UNIT	REMARK
Lamp voltage	V _L	—	280	—	Vrms	—
Lamp current	I _L	—	1.5	—	mArms	—
Lamp power consumption	P _L	—	0.42	—	W	(*1)
Starting voltage	V _S	—	—	620	Vrms	—
Lamp frequency	F _L	—	45-50	—	KHz	—
Lamp life time	L _L	10000	—	—	hrs	IL = 1.5 mArms (*2)

(*1) Power consumption excluded inverter loss .

(*2) LED life time is defined as the time taken for the brightness to be reduced to 50% of its original value.

3-3.CHARACTERISTICS OF TOUCH SCREEN

Touch screen Rating

Temp.=25°C

ITEM	SYMBOL	CONDITION	MIN.	TYP.	MAX.	UNIT
Applied Rating Voltage	V_R	—	—	—	7.0	V
Operating Temperature	T_{OPR}	20%~85% R.H. Max. Avoid Dew Condensation at Any Time	0	—	50	°C
Storage Temperature	T_{STO}		-20	—	70	
Resistance of Terminal Electrodes	R_{ETD}	X Electrode	200	—	800	Ω
		Y Electrode	200	—	800	
Linearity	L	—	—	—	1.5	%
Insulation Resistance	R_{OFF}	$V_{DC} = 25V$	20	—	—	M Ω
Transparency	T	According to JIS-K7015	82	85	—	%
Surface Hardness	S_H	According to JIS-K5400	3	—	—	H

4. OPTICAL CHARACTERISTICS

4-1 Optical Characteristics of LCD

AT Vop

ITEM MODE		Cr(Contrast Ratio)						θ (Viewing Angle)		ϕ (Viewing Angle)	
		0°C		25°C		50°C		25°C		25°C	
		MIN.	TYP.	MIN.	TYP.	MIN.	TYP.	MIN.	TYP.	MIN.	TYP.
T	M	10.5	13.5	16	20	7.0	10	—	90	—	±54
note		NOTE 6						NOTE 5			

NOTE :

T: TRANSMISSION

M: COLOR STN MODULE,

6 O'CLOCK **Viewing Direction** (NOTE 5)

AT $\phi=0^\circ$ $\theta=0^\circ$

ITEM	SYMBOL	CONDITION	MIN.	TYP.	MAX.	UNIT	NOTE
Response Time (rise)	Tr	0°C	800	1000	1200	ms	NOTE 2
		25°C	340	420	500		
		50°C	270	340	410		
Response Time (fall)	Tf	0°C	360	450	540	ms	NOTE 2
		25°C	130	160	190		
		50°C	70	90	110		

(NOTE 1)

Definition of Operation Voltage(V_{op})

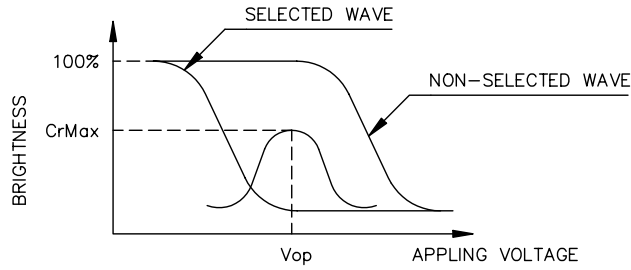

(positive type)

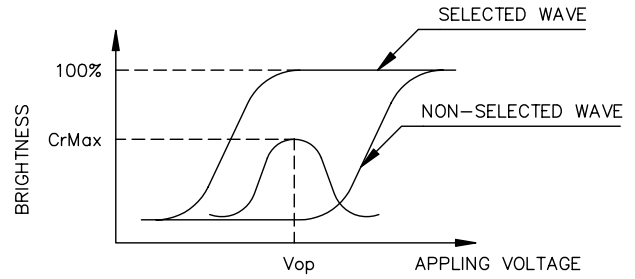

(negative type)

*Conditions

- Viewing Angle : 0
- Frame Frequency : 70Hz
- Applying Waveform : 1/N duty 1/a bias

(NOTE 2)

Definition of Response Time(T_r, T_f)

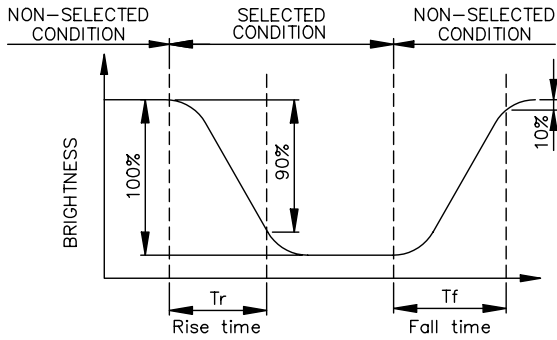

(positive type)

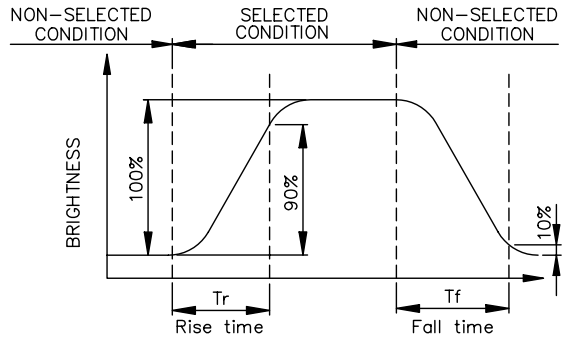

(negative type)

*Conditions

- Operating Voltage : V_{op}
- Viewing Angle (θ, ϕ) : (0,0)
- Frame Frequency : 70Hz
- Applying Waveform : 1/N duty 1/a bias

(NOTE 3)

Description of Measuring Equipment and Driving Waveforms

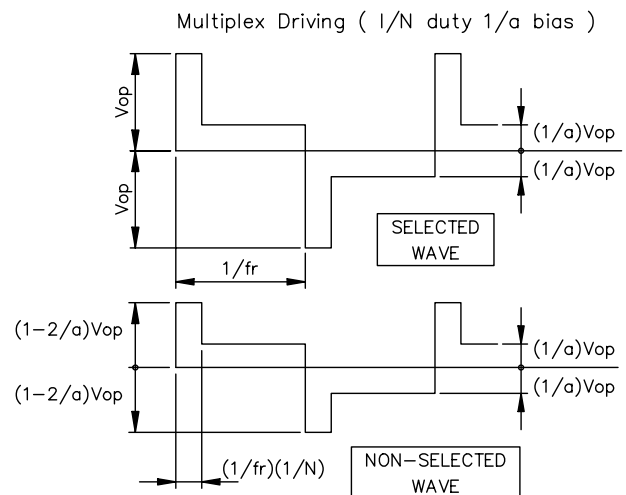
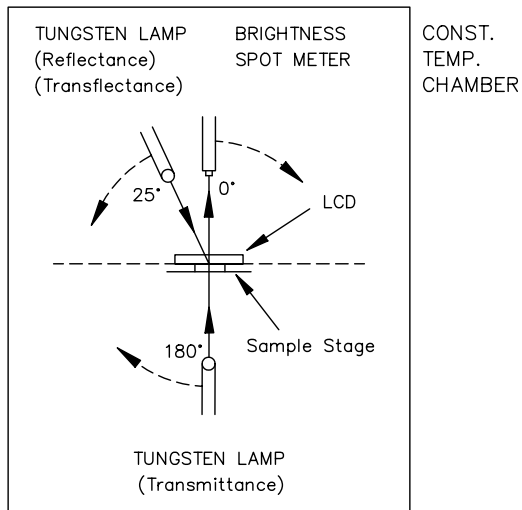

(NOTE 4)

Definition of Viewing Direction

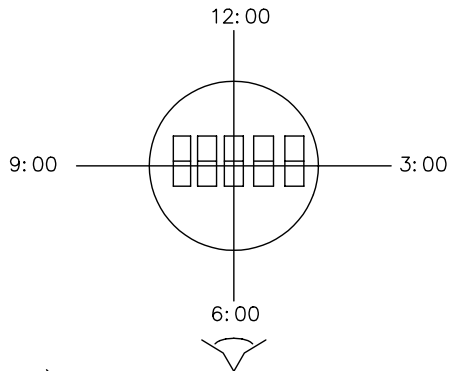

(NOTE 5)

Definition of Viewing Angle

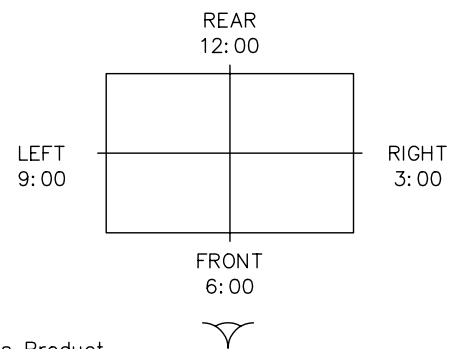
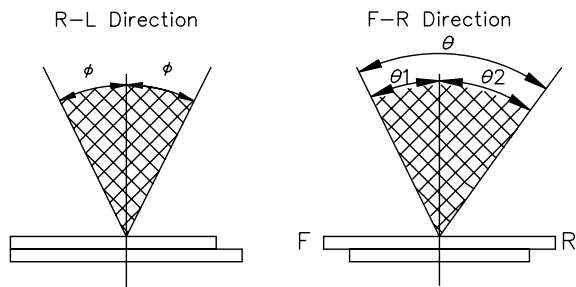

*For This Product
The Viewing Direction Is 6 O'clock
So $\theta_1 > \theta_2$

$$\theta = \theta_1 + \theta_2$$

*Conditions

Operating Voltage : V_{op}
Frame Frequency : 70Hz
Applying Waveform : 1/N duty 1/a bias
Contrast Ratio : larger than 2

(NOTE 6)

Definition of Contrast Ratio (Cr)

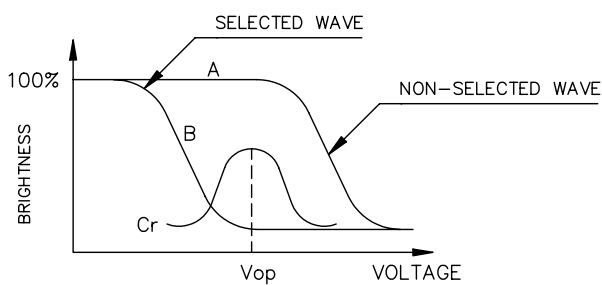

(positive type)

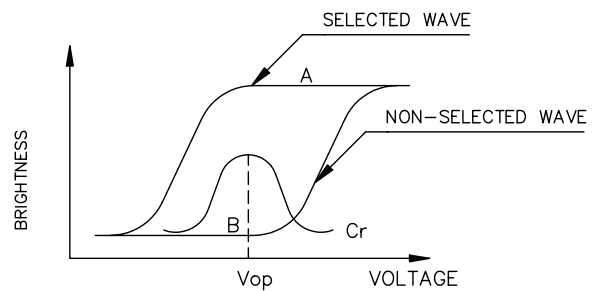

(negative type)

$$\text{Contrast Ratio : } Cr = A/B$$

*Conditions

Viewing Angle : 0
Frame Frequency : 70Hz
Applying Waveform : 1/N duty 1/a bias

4-2 Color of CIE Coordinate

T_a = 25°C

ITEM		SYMBOL	CONDITION	VALUE	BRIGHTNESS (cd/m ²)	NOTE
Color of CIE Coordinate	Red	X	$\phi=0^\circ, \theta=0^\circ$	0.495	22.4	Fig.1
		y		0.332		
	Green	X		0.296	49.0	
		y		0.519		
	Blue	X		0.172	15.2	
		y		0.167		
	White	X		0.310	80.5	
		y		0.350		

Tolerance : ±0.05

CIE chromaticity diagram

Fig.1

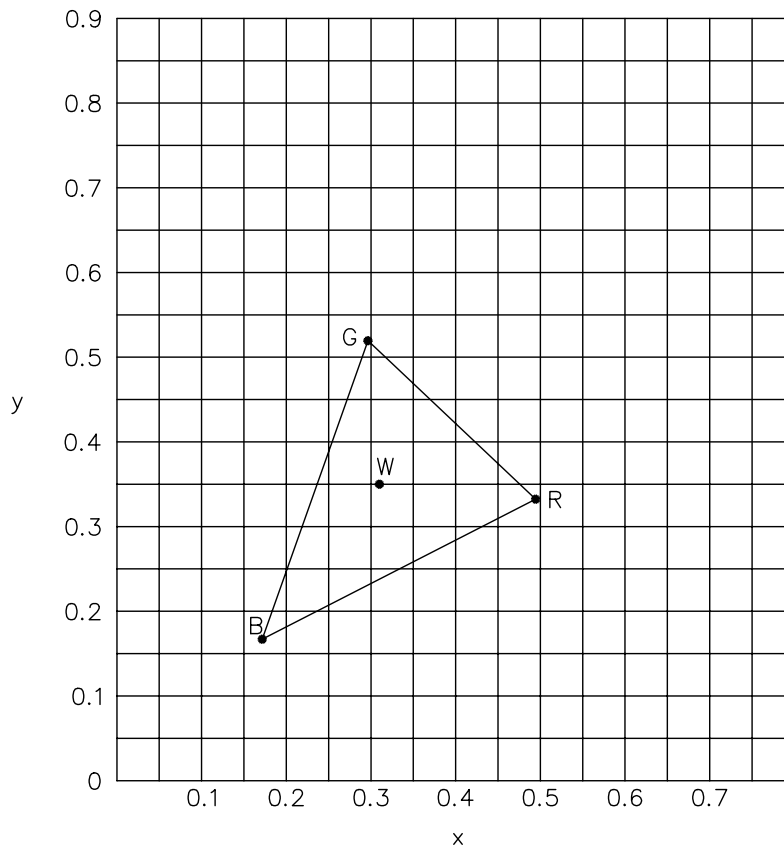

5. BLOCK DIAGRAM

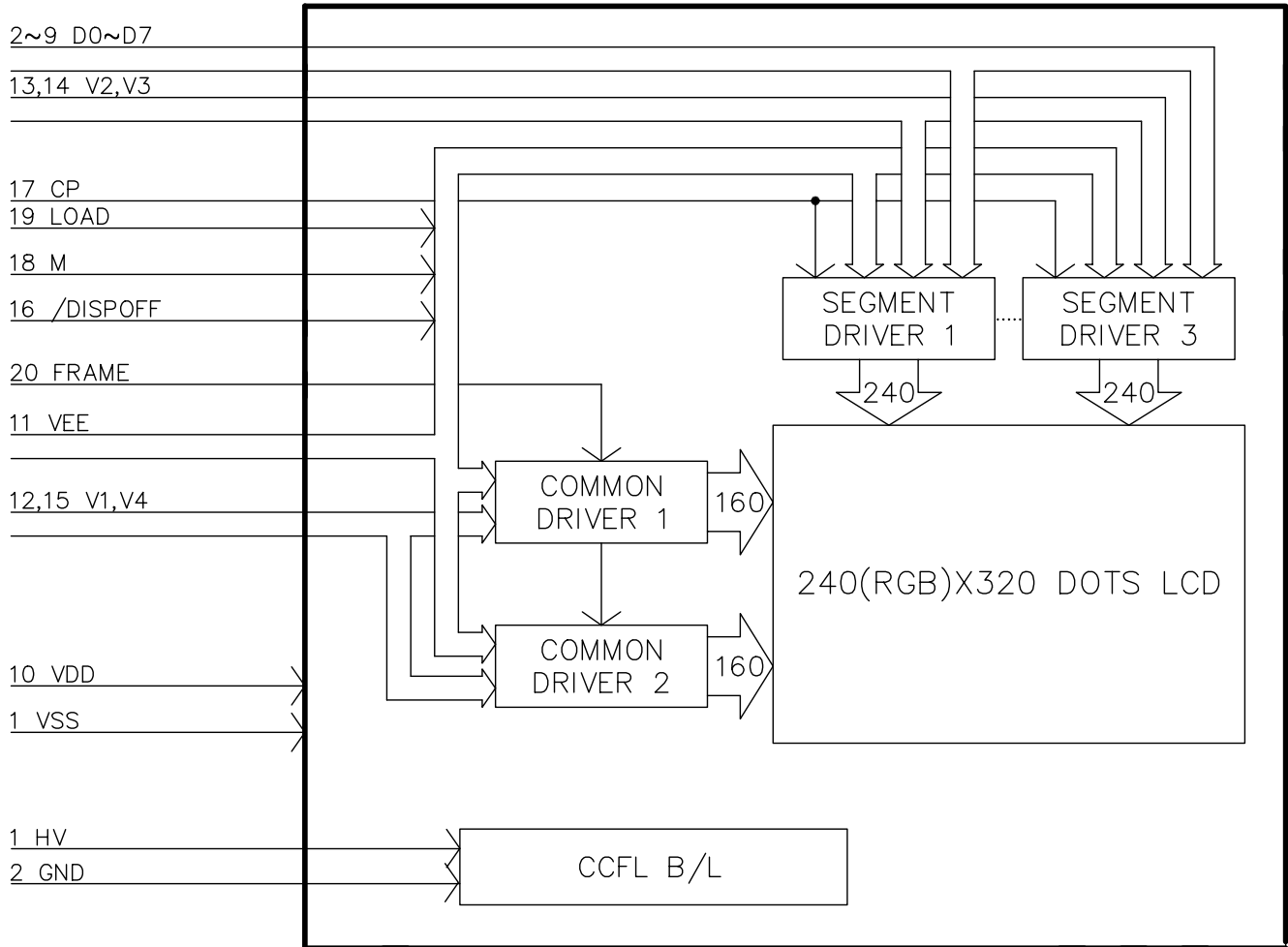

Note :

- 1) Controller and bias voltage supply circuit are not included.
- 2) VEE, V1, V2, V3, V4 and VSS are power supply voltages for the LCD.
(VEE > V1 > V2 > V3 > V4 > VSS)

6. INTERNAL PIN CONNECTION

CN1 : (FPC) PITCH 0.5mm WIDTH 10.5mm

PIN NO.	SYMBOL	FUNCTION
1	VSS	Power Supply for Logic (GND) Power Supply for LCD (COM/SEG Selected Level)
2	D0	DISPLAY DATA
3	D1	DISPLAY DATA
4	D2	DISPLAY DATA
5	D3	DISPLAY DATA
6	D4	DISPLAY DATA
7	D5	DISPLAY DATA
8	D6	DISPLAY DATA
9	D7	DISPLAY DATA
10	VDD	Power Supply for Logic (+3.0V)
11	VEE	Power Supply for LCD (COM/SEG Selected Level)
12	V1	Power Supply for LCD (COM Non-Selected Level)
13	V2	Power Supply for LCD (SEG Non-Selected Level)
14	V3	Power Supply for LCD (SEG Non-Selected Level)
15	V4	Power Supply for LCD (COM Non-Selected Level)
16	$\overline{\text{DISPOFF}}$	Display Control L: off H: on
17	CP	Display Data Shift Clock
18	M	AC Signal for LC
19	LOAD	Display Data Latch Clock
20	FRAME	FRAME CLOCK

CN2 : BHSR-02VS-1(JST) (PIN1-HOT;PIN2-GND)

1	H.V.	Power Supply Voltage for CCFL
2	GND	CCFL GND

7. POWER SUPPLY

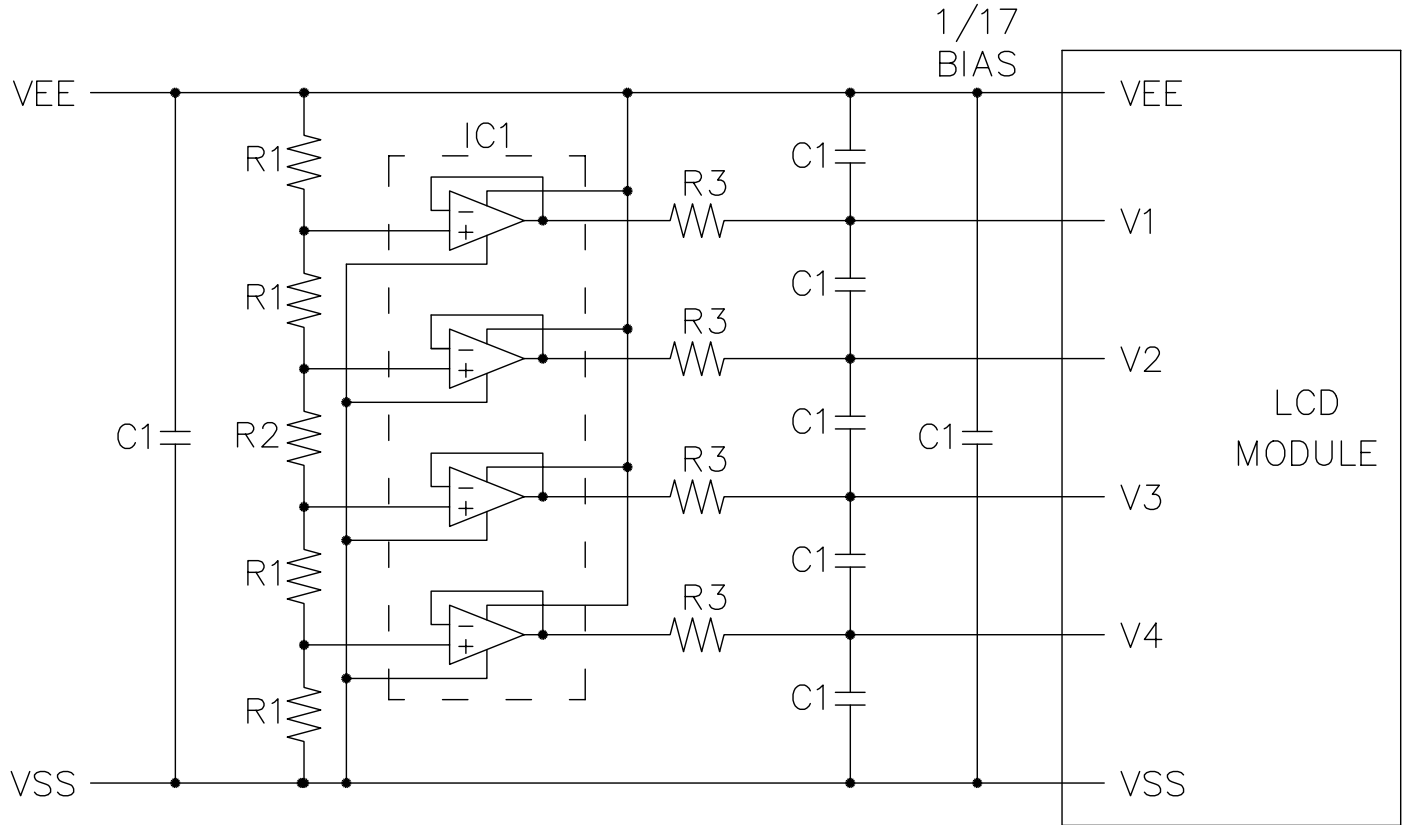

IC1 : LP324M(NATIONAL SEMICONDUCTOR)
 R1 : 22(KOHM) \pm 0.5%, R2 : 287(KOHM) \pm 2%, R3 : 4.7(OHM) \pm 5%
 C1 : 2.2-4.7(uF)

8. TIMING CHARACTERISTICS

8-1. INTERFACE TIMING

VDD=3.0V±10%

Item	Symbol	Test condition	Min.	Typ.	Max.	Unit
CP Cycle Time	tC	Fig.a	82	-	-	ns
CP Pulse Width	tSWH,tSWL	Fig.a	28	-	-	ns
CP Rise/Fall Time	tCR,tCF	Fig.a	-	-	50	ns
Data Set Up Time	tDSU	Fig.a , Fig.b	100	-	-	ns
Data Hold Time	tDHD	Fig.a , Fig.b	30	-	-	ns
LOAD Cycle Time	tL	Fig.b	250	-	-	ns
LOAD "H" Pulse Width	tLWH	Fig.a , Fig.b	100	-	-	ns
LOAD Rise/Fall Time	tLR,tLF	Fig.b	-	-	30	ns
CP To LOAD Delay Time	tCL	Fig.a	30	-	-	ns
LOAD To CP Delay Time	tLC	Fig.a	-	-	200	ns
FRAME TO LOAD SETUP TIME	tFLS	Fig.b	30	-	-	ns
FRAME TO LOAD HOLD TIME	tFLH	Fig.b	50	-	-	ns

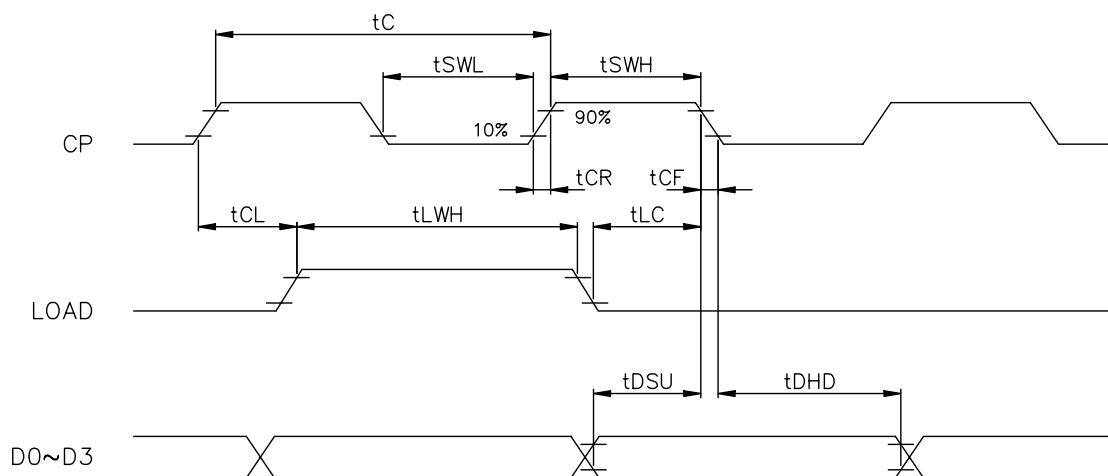

Fig . a Interface timing (SEGMENT)

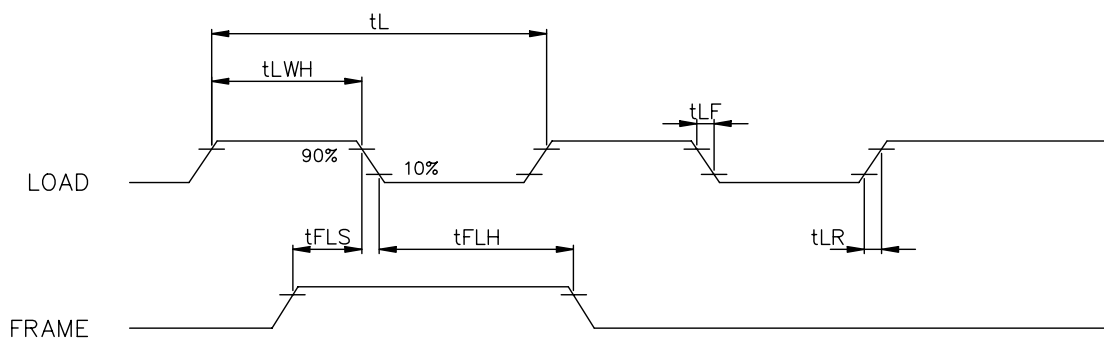
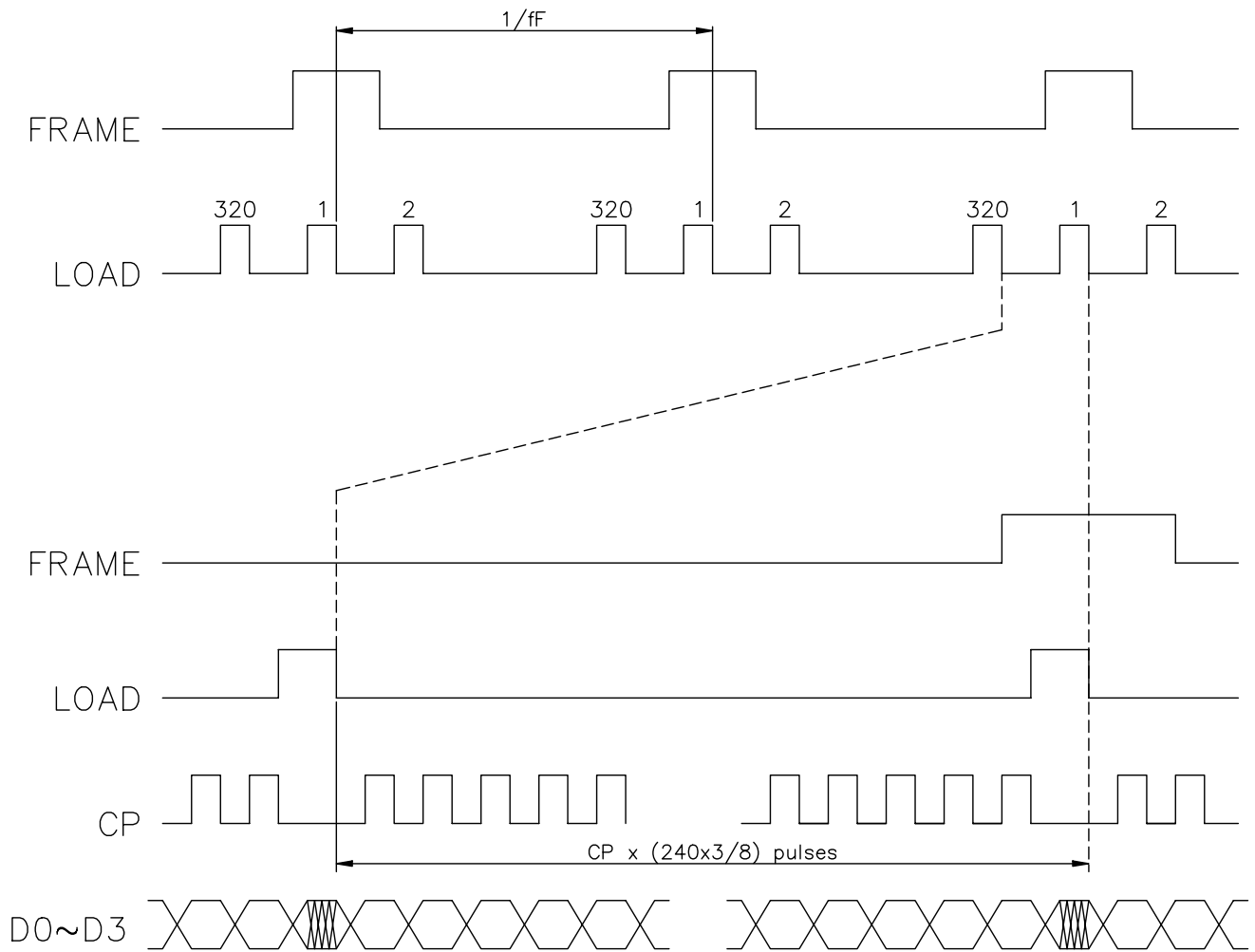
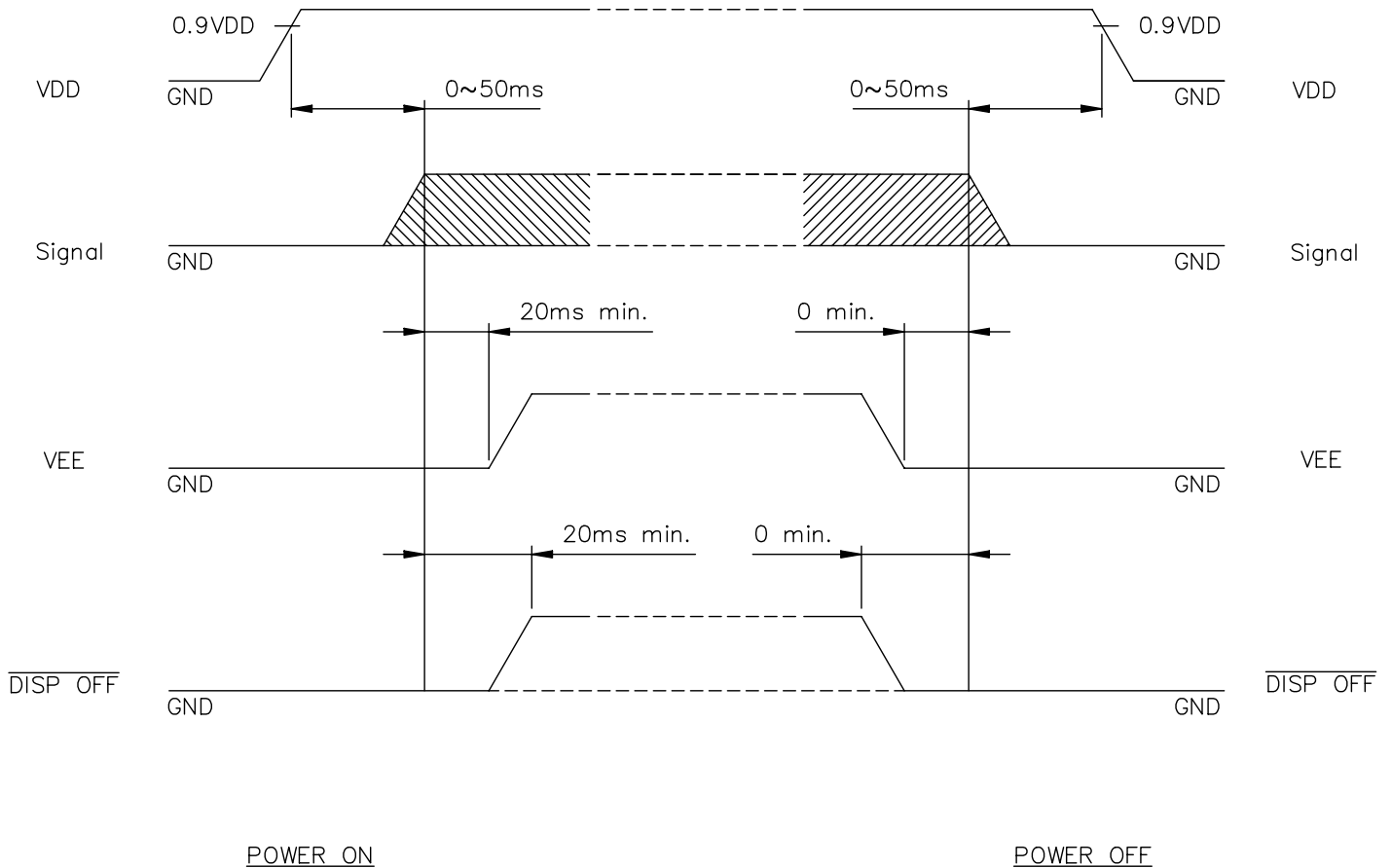

Fig . b Interface timing (COMMON)

8-2. TIMING CHART OF INPUT SIGNAL



8-3. POWER ON/OFF TIMING



Missing pixels may occur when the LCM is driven beyond the above power interface timing sequence.

8-4.DISPLAY PATTERN

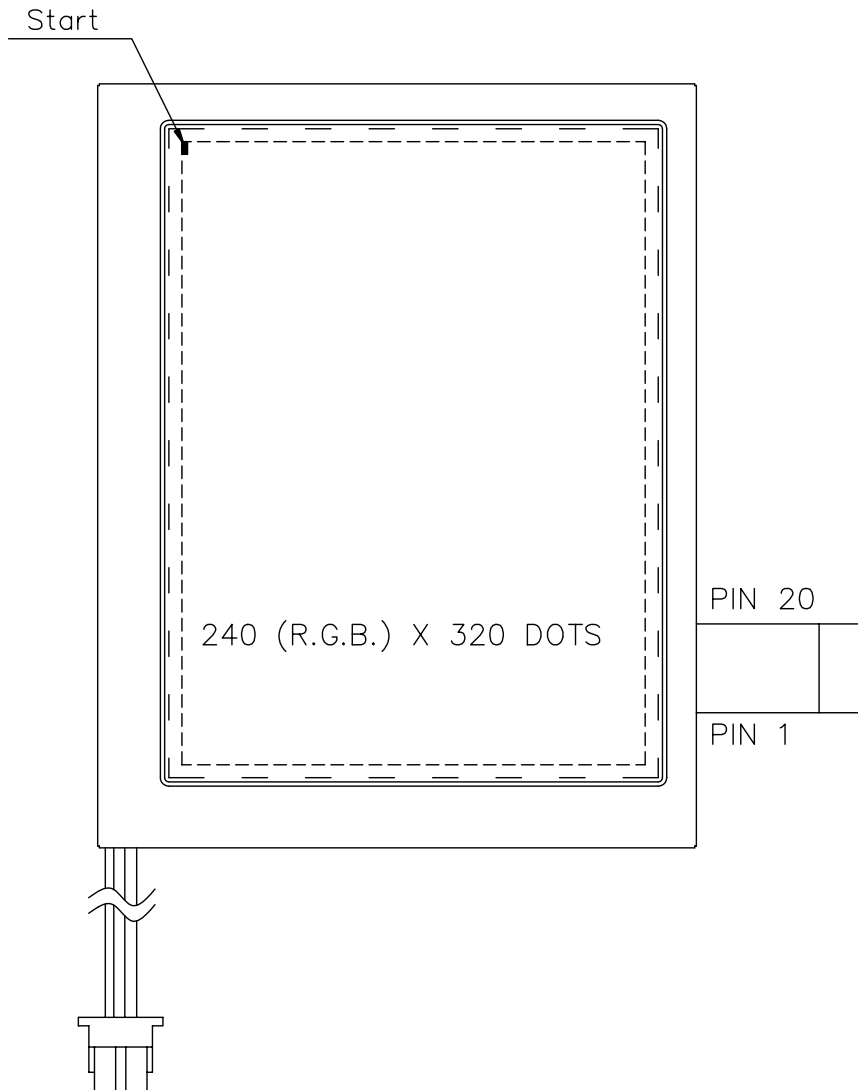
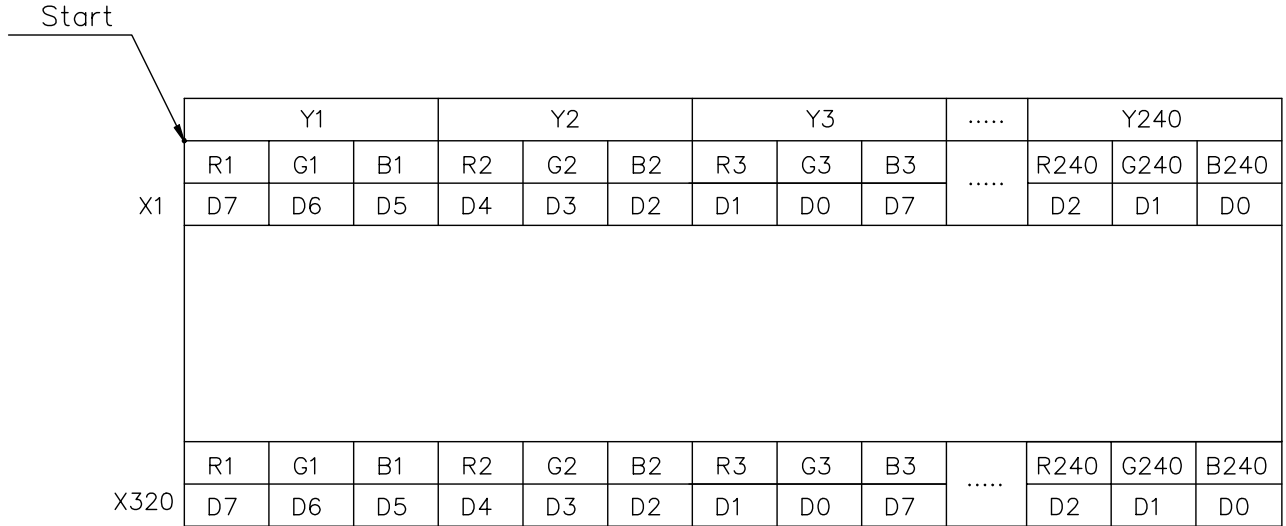

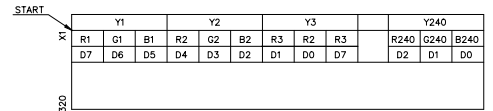
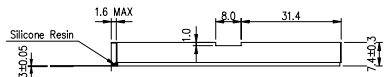

DISPLAY PATTERN

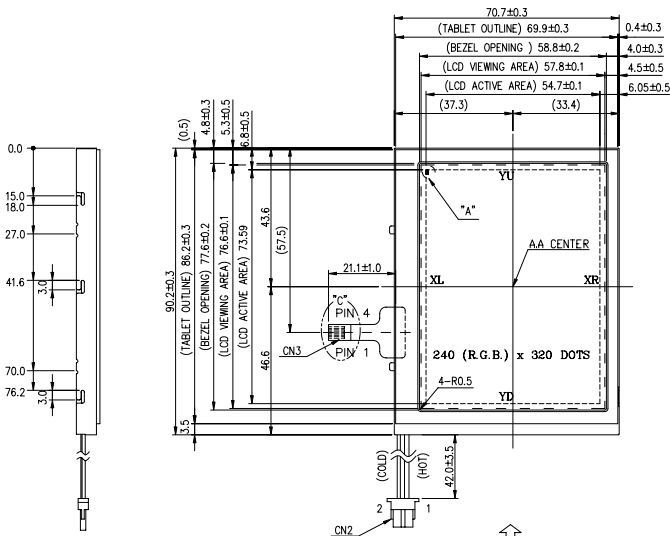

VIEW DIRECTION

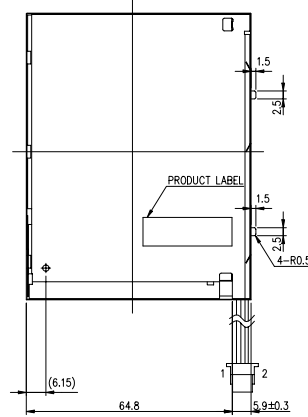
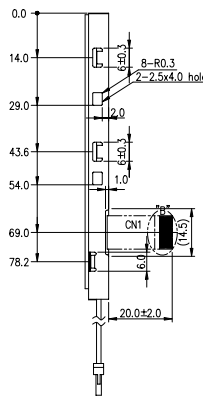

CN3 FOR TOUCH PANEL

PIN NO.	SYMBOL
1	XR
2	YD
3	XL
4	YU

NOTE:
1. RESOLUTION: 240 (R.G.B.) x320 DOTS
2. BACKLIGHT: CCFL

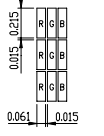

DETAIL "A"
(SCALE 40:1)

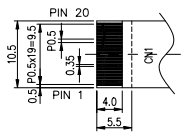

DETAIL "B"
(SCALE 2:1)

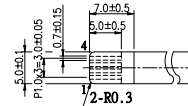
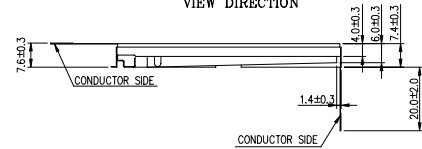

DETAIL "C"
(SCALE 2:1)

DIMENSION	TOLERANCE
$L \leq 6$	± 0.25 (mm)
$6 < L \leq 18$	± 0.3 (mm)
$18 < L \leq 50$	± 0.4 (mm)
$50 < L \leq 125$	± 0.5 (mm)
$125 < L$	± 0.6 (mm)
ANGLE	$\pm 1^\circ$ (DEG)

CN1 : (FPC) PITCH 0.5mm WIDTH 10.5mm

PIN NO.	SYMBOL	FUNCTION	PIN NO.	SYMBOL	FUNCTION
1	V _{SS}	POWER SUPPLY FOR LOGIC (GND)	12	V1	POWER SUPPLY FOR LCD (COM NON-SELECTED LEVEL)
2	D0	POWER SUPPLY FOR LCD (COM/SEG SELECTED LEVEL)	13	V2	POWER SUPPLY FOR LCD (SEG NON-SELECTED LEVEL)
3	D1	DISPLAY DATA	14	V3	POWER SUPPLY FOR LCD (SEG NON-SELECTED LEVEL)
4	D2	DISPLAY DATA	15	V4	POWER SUPPLY FOR LCD (COM NON-SELECTED LEVEL)
5	D3	DISPLAY DATA	16	DISPGFF	DISPLAY CONTROL L:OFF H:ON
6	D4	DISPLAY DATA	17	CP	DISPLAY DATA SHIFT CLOCK
7	D5	DISPLAY DATA	18	M	AC SIGNAL FOR LC
8	D6	DISPLAY DATA	19	LOAD	DISPLAY DATA LATCH CLOCK
9	D7	DISPLAY DATA	20	FRAME	FRAME CLOCK
10	V _{DD}	POWER SUPPLY FOR LOGIC (+3.0V)	CN2 : BHSR-02VS-1(JST) (PIN1-HOT;PIN2-GND)		
11	V _{EE}	POWER SUPPLY FOR LCD (COM/SEG SELECTED LEVEL)	1	H.V	POWER SUPPLY VOLTAGE FOR CCFL
			2	GND	CCFL GND

AZ DISPLAYS, INC.

AGM3224V

REV. NO.	DESCRIPTION	DATE	DESIGN	CHECK	APPROVE	DWG NO.	NAME	DATE	THIRD ANGLE P.
1	修改機種(T461M1T~T461M2) 及機殼(M461-D1A~M461AD2A)	90.10.05	Y.C.LIU			M461AD2A	TONY CHOU	90.07.12	☉
							Y. C. LIU	90.07.09	
							C. J. CHEN	90.07.09	SCALE UNIT
							C. J. CHEN	90.07.09	1/1 mm