

AZ DISPLAYS, INC.

1. MECHANICAL DATA

(1) Product No.	AGM6448C
(2) Module Size	260.0 (W)mm x 174.0 (H)mm x MAX8.0 (D)mm
(3) Dot Size	0.27 (W)mm x 0.27 (H)mm
(4) Dot Pitch	0.30 (W)mm x 0.30 (H)mm
(5) Number of Dots	640 (W) x 480 (H)Dots
(6) Duty	1/240
(7) LCD Display Mode	FSTN: Black and White(Normally Black/Negative Image) Rear Polarizer: Transmissive
(8) Viewing Direction	6 O'clock
(9) Backlight	CCFL
(10) Controller	Excluded
(11) DC/DC Converter	Excluded
(12) Weight	352.0 g(approx.)
(13) Recommended CFL Inverter	TDK CORP. CXA-L10L

Revised: March 7, 2000

2. ABSOLUTE MAXIMUM RATINGS

(1) ELECTRICAL ABSOLUTE RATINGS

VSS=0 V

ITEM	SYMBOL	MIN	MAX	UNIT	COMMENT
Power Supply for Logic	VDD	-0.3	6.5	V	
Power Supply for LCM	VDD-VEE	0	30	V	
Input Voltage	VI	-0.3	VDD+0.3	V	
Static Electricity	-	-	-	-	Note 1

Note 1 LCM should be grounded during handling LCM.

(2) ENVIRONMENTAL ABSOLUTE MAXIMUM RATINGS

ITEM	NORMAL TEMP.			
	OPERATION		STORAGE	
	MIN.	MAX.	MIN.	MAX.
Ambient Temperature	0	50	-20	70
Humidity (Without Condensation)	Note 2,4		Note 3,4	
Vibration ※	-		49m/s ² (5G)	

Note 2 Ta ≤ 50°C : 85%RH max

Ta > 50°C : Absolute humidity must be lower than the humidity of 85%RH at 50°C

Note 3 Ta at -20°C will be < 48 hrs, at 70°C will be < 120 hrs

Note 4 Background color will change slightly depending on ambient temperature. This phenomenon is reversible.

Note※

Frequency (HZ)	10~55~10/1 min
Vibration Width	1.5 m/m
Vibration Direction	X/Y/Z
Vibration Time	15 min/cycle X 3 directions

3. ELECTRICAL CHARACTERISTICS

ITEM		SYMBOL	CONDITION	MIN.	TYP.	MAX.	UNIT	
Power Supply for Logic		VDD-VSS	-	4.75	5.0	5.25	V	
Recommended LC Driving Voltage		VDD-VEE	Duty=1/240 Bias=1/13	0°C	23.3	23.7	24.1	V
				25°C	22.1	22.5	22.9	
				50°C	20.7	21.1	21.5	
Input Voltage		VIH	H level	0.8VDD	-	VDD	V	
		VIL	L level	0	-	0.2VDD	V	
Power Supply Current		IDD	FLM = 70 Hz VDD = 5.0 V VDD-VEE=22.5V	-	17	30	mA	
		IEE	PATTERN : <div style="display: flex; justify-content: space-around; align-items: center;"> □■□■□■ </div> <div style="display: flex; justify-content: space-around; align-items: center;"> ■□■□■□ </div>	-	15	25	mA	
CCFL LAMP	Starting Voltage	Vs		-	600	-	Vrms	
	Lamp Voltage	VL		-	380	-	Vrms	
	Lamp Current	IL		4	5	6	mArms	
	Lamp Consumption	PL		-	1.9	-	W	
	Lamp Frequency	FL		-	40	-	kHz	
	Lamp Life Time	LL		NOTE 1	15000	-	-	hrs
LCM	Surface Luminance	L	ALL ON	-	56.3	-	cd/m ²	
			ALL OFF	-	6.3	-		

NOTE 1: Lamp life is measured in half-life; that is, the time it takes the brightness to reduce to 50% of its initial value.

4.OPTICAL CHARACTERISTICS

(For Normal Temperature Mode LCM)

AT V_{OP}

ITEM MODE		Cr(Contrast Ratio)						θ (Viewing Angle)		ϕ (Viewing Angle)	
		0°C		25°C		50°C		25°C		25°C	
		MIN.	TYP.	MIN.	TYP.	MIN.	TYP.	MIN.	TYP.	MIN.	TYP.
T	G	-	6.0	-	10.0	-	3.0	-	45	-	40-20
Note		see page 6 (Note 6)						see page 6 (Note 5)			

NOTE :

T: TRANSMISSIVE

G: NORMALLY BLACK

AT $\phi=0^\circ$ $\theta=0^\circ$

ITEM	SYMBOL	CONDITION	MIN.	TYP.	MAX.	UNIT	NOTE
Response Time (rise)	Tr	0℃	-	400	-	ms	see page 5 (Note 2)
		25℃	-	200	-		
		50℃	-	110	-		
Response Time (fall)	Tf	0℃	-	250	-	ms	see page 5 (Note 2)
		25℃	-	80	-		
		50℃	-	70	-		

(NOTE 1)

Definition of Operation Voltage(Vop)

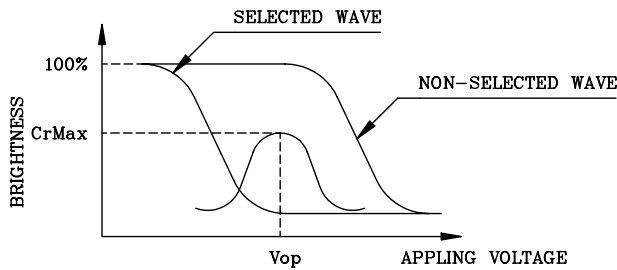

(positive type)

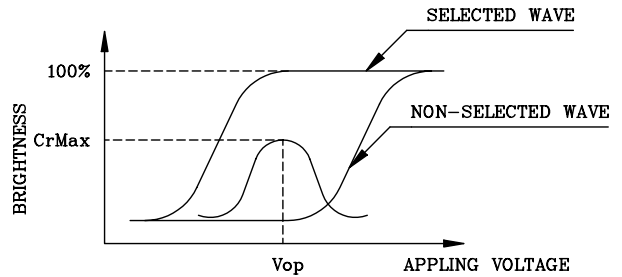

(negative type)

*Conditions

- Viewing Angle : 0
- Frame Frequency : 70Hz
- Applying Waveform : I/N duty 1/a bias

(NOTE 2)

Definition of Response Time(Tr,Tf)

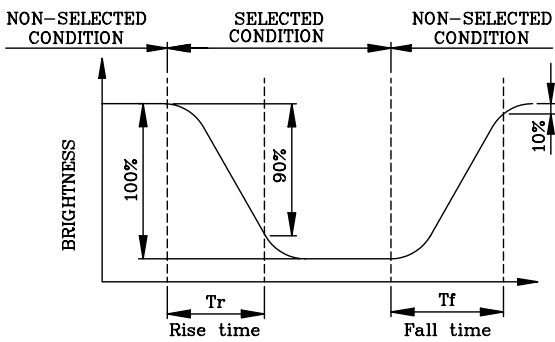

(positive type)

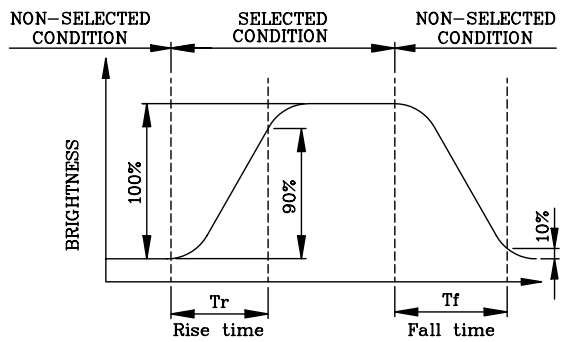

(negative type)

*Conditions

- Operating Voltage : Vop
- Viewing Angle (θ,φ) : (0,0)
- Frame Frequency : 70Hz
- Applying Waveform : I/N duty 1/a bias

(NOTE 3)

Description of Measuring Equipment and Driving Waveforms

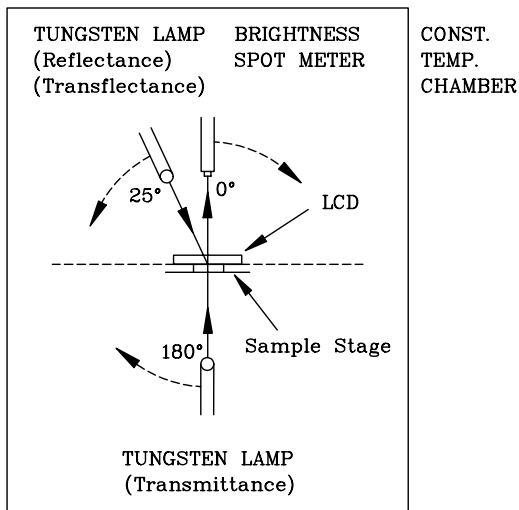

Multiplex Driving (I/N duty 1/a bias)

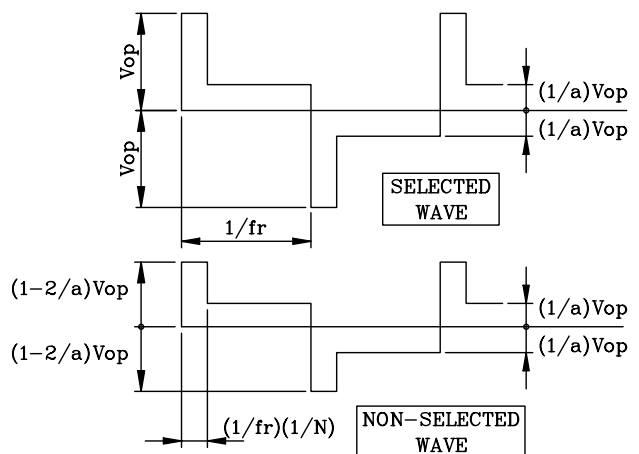

(NOTE 4)

Definition of Viewing Direction

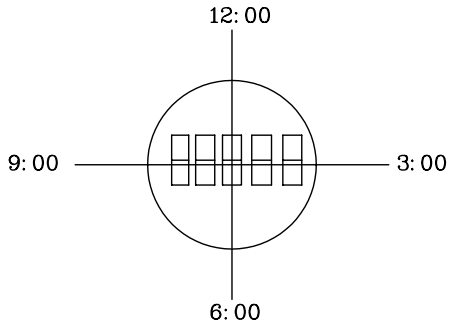

(NOTE 5)

Definition of Viewing Angle

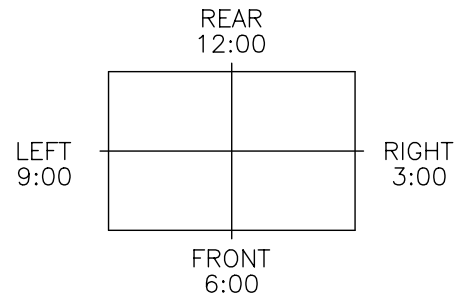
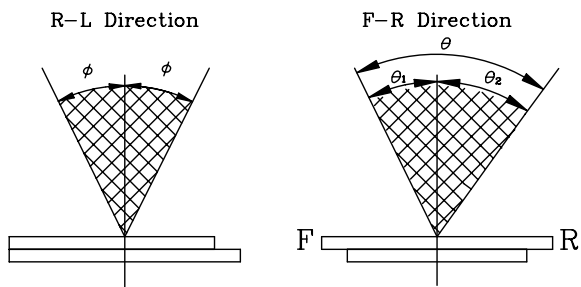

*For This Product
The Viewing Direction Is 6 O'clock
So $\theta_1 > \theta_2$

$$\theta = \theta_1 + \theta_2$$

*Conditions

Operating Voltage : V_{op}
Frame Frequency : 70Hz
Applying Waveform : 1/N duty 1/a bias
Contrast Ratio : larger than 2

(NOTE 6)

Definition of Contrast Ratio (Cr)

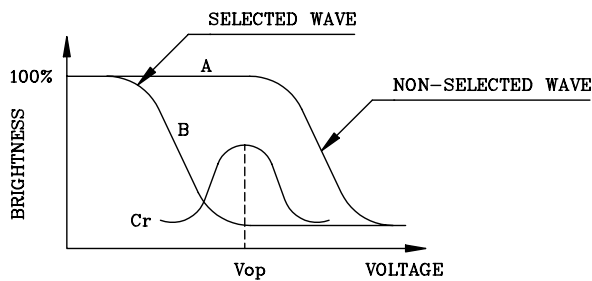

(positive type)

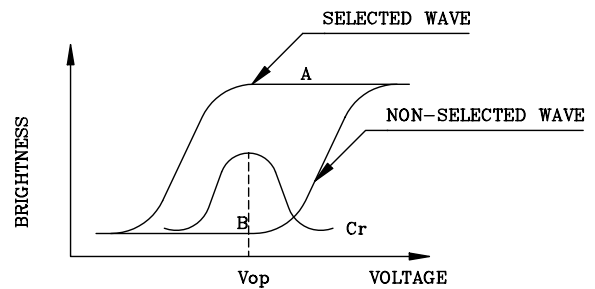

(negative type)

$$\text{Contrast Ratio : } Cr = A/B$$

*Conditions

Viewing Angle : 0
Frame Frequency : 70Hz
Applying Waveform : 1/N duty 1/a bias

5. BLOCK DIAGRAM

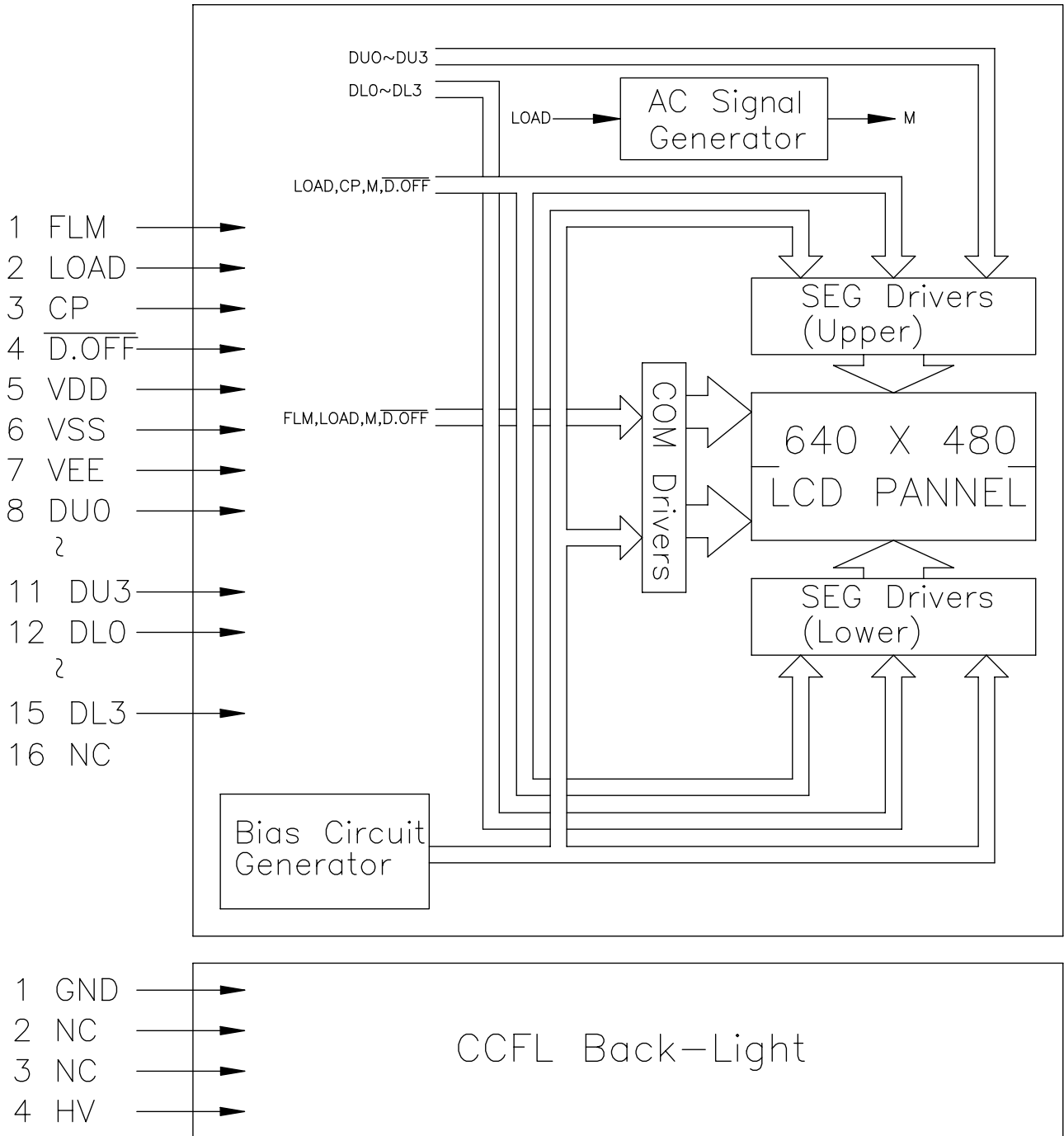

* AC Signal Setting

J1	J2	J3	J4	J5	J6	J7	J8
H	L	L	H	H	L	L	L

6. INTERNAL PIN CONNECTION

LCD

Pin No.	Symbol	Level	Function
1	FLM	H/L	SCAN START-UP SIGNAL
2	LOAD	H→L	DATA LATCH PULSE
3	CP	H→L	DATA SHIFT PULSE
4	$\overline{D.OFF}$	H/L	DISPLAY OFF ("H"=ON,"L"=OFF)
5	VDD	-	POWER SUPPLY FOR LOGIC (+5V)
6	VSS	-	SIGNAL GROUND (GND)
7	VEE	-	POWER SUPPLY FOR LCD (-V)
8	DU0	H/L	DISPLAY DATA (UPPER HALF)
9	DU1		
10	DU2		
11	DU3		
12	DL0	H/L	DISPLAY DATA (LOWER HALF)
13	DL1		
14	DL2		
15	DL3		

CCFT

Pin No.	Symbol	Level	Function
1	GND	-	GROUND LINE (INVERTER)
2	NC	-	NON CONNECTION
3	NC	-	NON CONNECTION
4	HV	-	HIGH VOLTAGE LINE (INVERTER)

LCD

Used connector : 53261-1590 (MOLEX)

Mating connector : 51021-1500 (MOLEX)

CCFT

Used connector : M63M83-04 (MITSUMI)

Mating connector : M60-04-30-114P (MITSUMI)

M60-04-30-134P (MITSUMI)

M61M73-04 (MITSUMI)

7. POWER SUPPLY

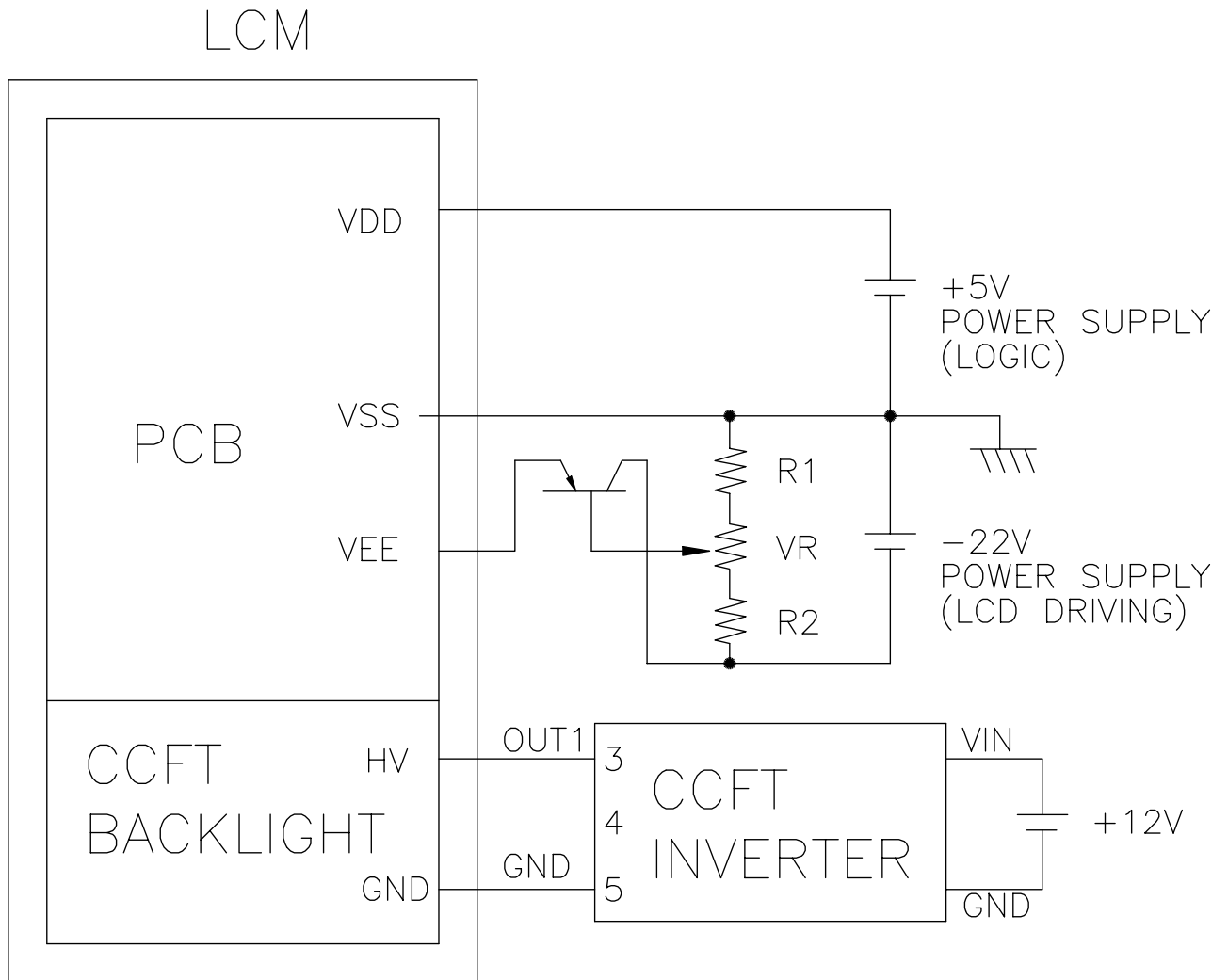

1. $R1 + VR + R2 = 10K \sim 20K\Omega$

2. RECOMMENDED CCFT INVERTER : CXA-L10L(TDK)

8. TIMING CHARACTERISTICS

8-1. INTERFACE TIMING

@VDD=4.5~5.5V

ITEM	SYMBOL	MIN.	TYP.	MAX.	UNIT
Shift Clock Period	t_{cp}	153	—	—	ns
CLOCK PULSE WIDTH	t_w	56	—	—	ns
CLOCK RISE, FALL TIME	t_r, t_f	—	—	20	ns
DATA SETUP TIME	t_{dsu}	50	—	—	ns
DATA HOLD TIME	t_{dhd}	40	—	—	ns
"CP" → "LOAD" FALL TIME	t_{lsu}	65	—	—	ns
"LOAD" → "CP" FALL TIME	t_{lc}	65	—	—	ns
FLM SETUP TIME	t_{setup}	100	—	—	ns
FLM HOLD TIME	t_{hold}	100	—	—	ns
LOAD PULSE WIDTH	t_{wc}	70	—	—	ns

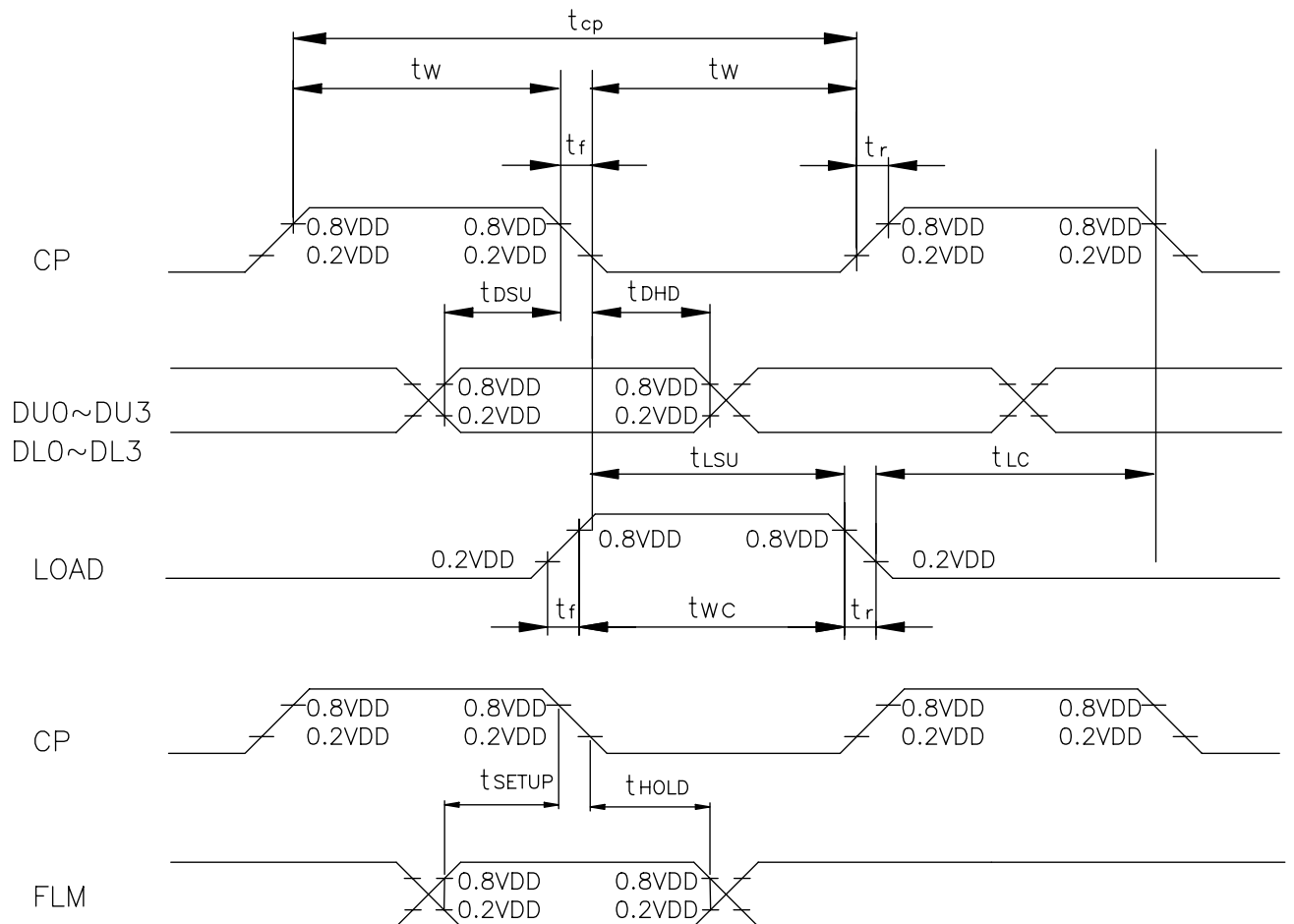

8-2. POWER ON/OFF TIMING

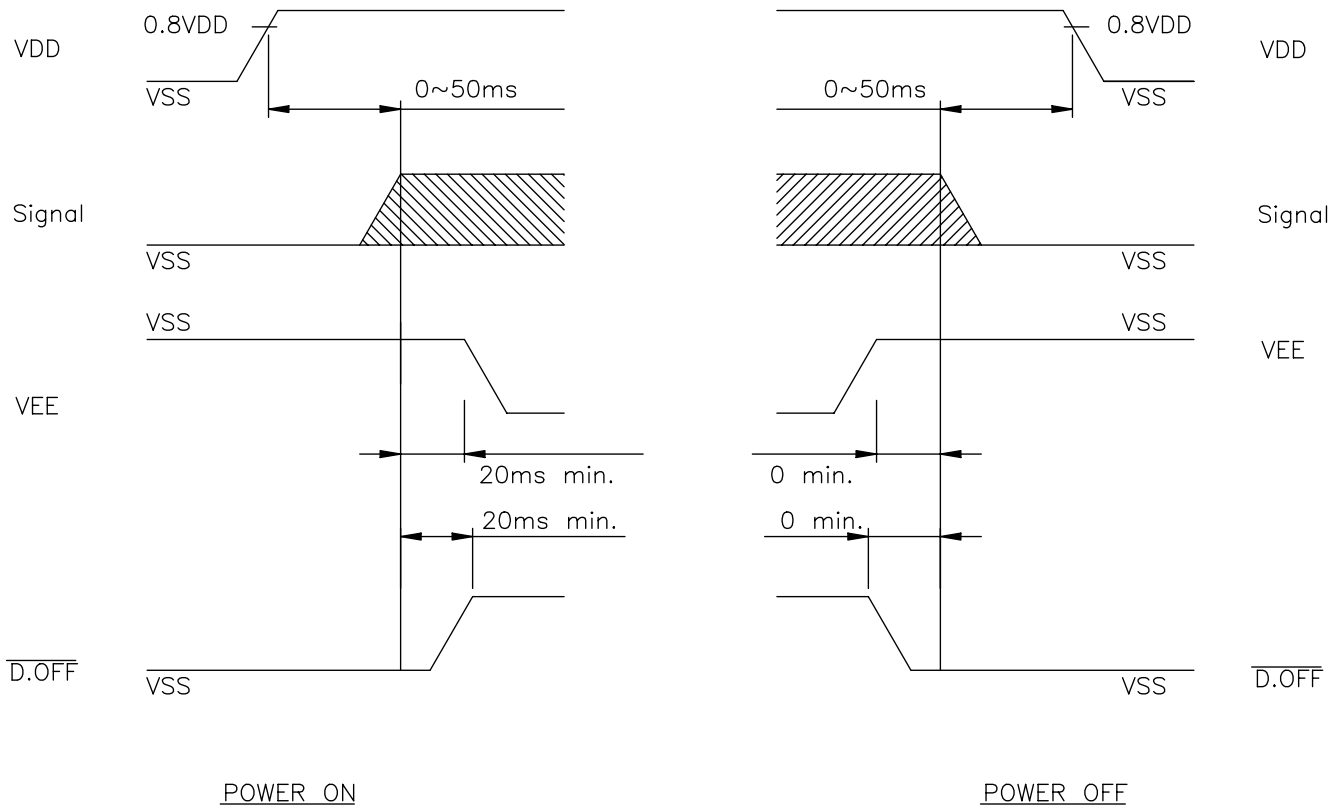

Missing pixels may occur when the LCM is driven beyond the above power interface timing sequence.

8-3.DISPLAY PATTERN

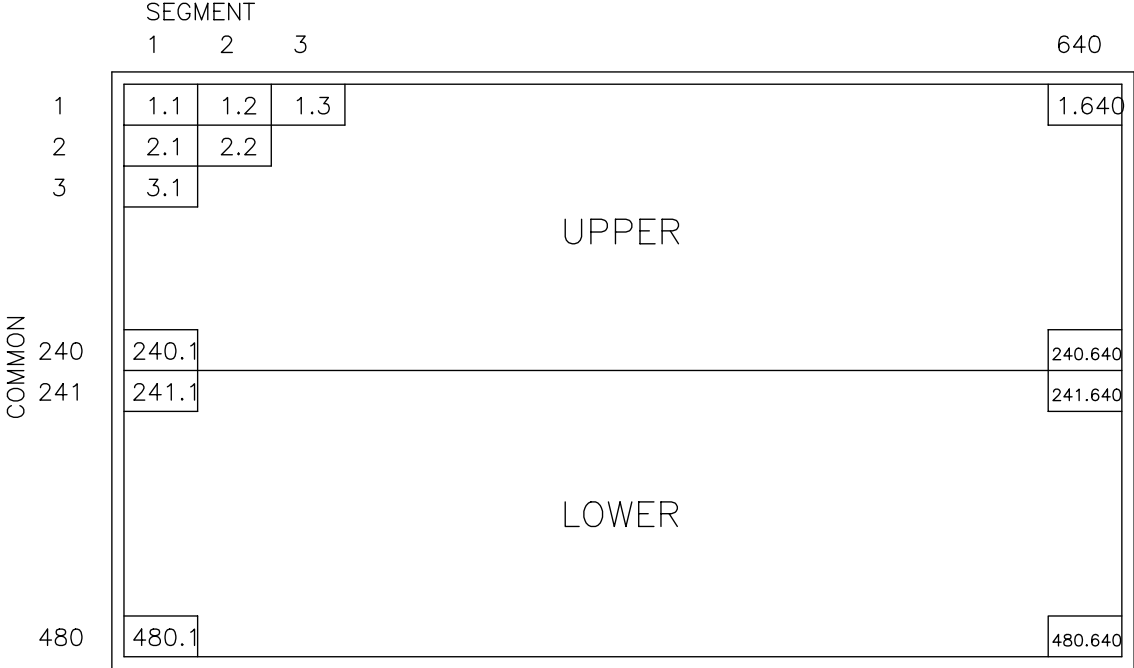

NOTE : 1.1 MEANS 1ST COMMON 1ST SEGMENT DOT

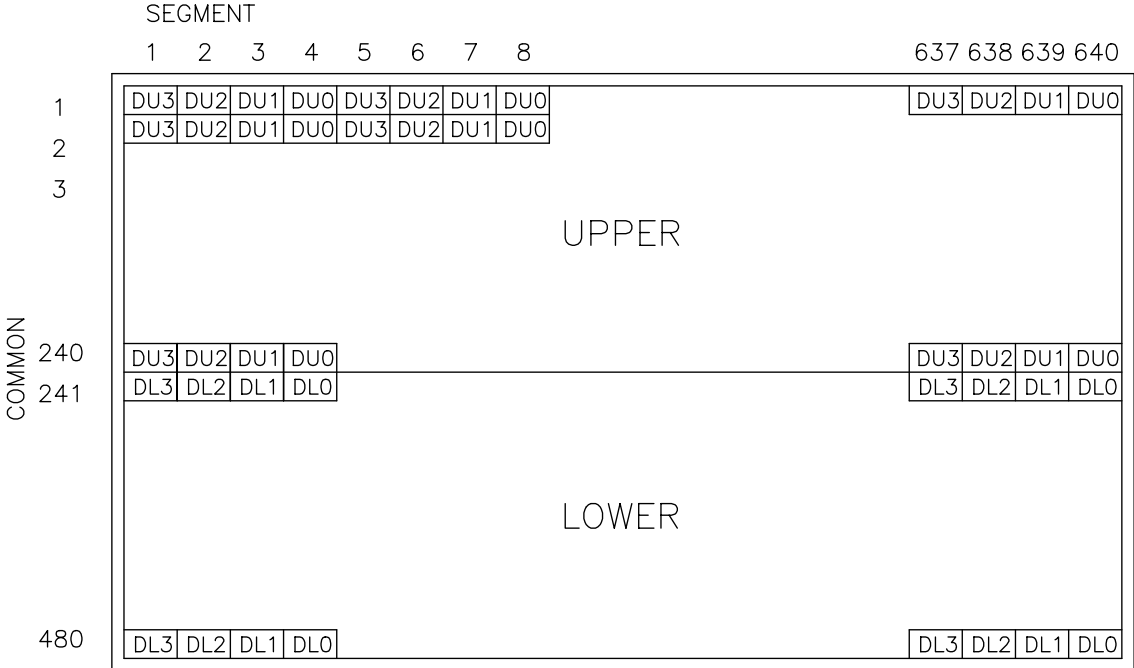

NOTE:

- ① INTERFACE CONNECTOR(15 PINS) :53261-1590(MOLEX)
- ② CCFL CONNECTOR : M63M83-04(MITSUMI)
(FOR CCFL B.L. ONLY)

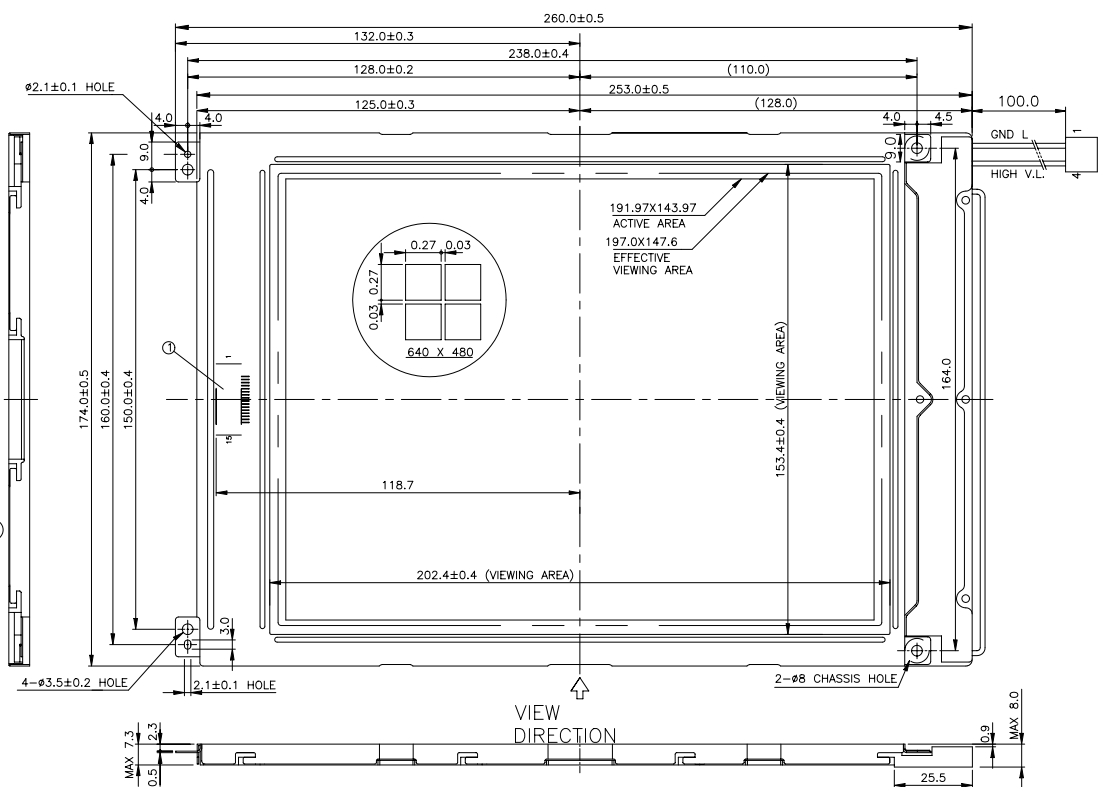

Pin No.	Symbol	Level	Function
1	FLM	H/L	SCAN START-UP SIGNAL
2	LOAD	H → L	DATA LATCH PULSE
3	CP	H → L	DATA SHIFT PULSE
4	D.OFF	H/L	DISPLAY OFF ("H"=ON,"L"=OFF)
5	VDD	-	POWER SUPPLY FOR LCD (+5V)
6	VSS	-	SIGNAL GROUND (GND)
7	VEE	-	POWER SUPPLY FOR LCD (-V)
8	DU0	H/L	DISPLAY DATA (UPPER HALF)
9	DU1		
10	DU2		
11	DU3	H/L	DISPLAY DATA (LOWER HALF)
12	DL0		
13	DL1		
14	DL2		
15	DL3		

DIMENSION	TOLERANCE
L ≤ 6	±0.25 (mm)
6 < L ≤ 18	±0.3 (mm)
18 < L ≤ 50	±0.4 (mm)
50 < L ≤ 125	±0.5 (mm)
125 < L	±0.6 (mm)
ANGLE	±1° (DEG)

AZ DISPLAYS, INC.

NAME	DATE	THIRD ANGLE P.
APPROVE		
CHECK		
DESIGN	SEAN HU 88.11.22	SCALE UNIT
DRAWN	J.S HUANG 88.11.19	1/0.75 mm
DWG NO.	AGM6448C	