

# AZ DISPLAYS, INC.

## 1. MECHANICAL DATA

(1) Product No.	<b>AGM6448T</b>
(2) Module Size	203.0 (W)mm X 142.5 (H)mm X 6.0 (D)mm
(3) Dot Size	0.067 (W)mm X 0.241 (H)mm
(4) Dot Pitch	0.087 (W)mm X 0.261 (H)mm
(5) Number of Dots	640 (R.G.B.) (W) X 480 (H) Dots
(6) Duty	1/240
(7) LCD Display Mode	FSTN: Color STN module Rear Polarizer: Color Transmission type
(8) Viewing Direction	12 O'clock
(9) Backlight	CCFL
(10) Controller	Excluded
(11) Weight	250 g Approx.

Date: March 22, 2002

## 2. ABSOLUTE MAXIMUM RATINGS

### (1) ELECTRICAL ABSOLUTE RATINGS

VSS=0V

ITEM	SYMBOL	MIN	MAX	UNIT	COMMENT
Power Supply for Logic	VDD-VSS	-0.3	+7.0	V	
Contrast Adjustment Voltage	Vcon-VSS	1.8	2.8	V	
Input Voltage	VIN	0	VDD	V	Note 1
Static Electricity	-	-	-	-	Note 2

Note 1  $\overline{\text{DISP.OFF}}, \text{M}, \text{CL1}, \text{CL2}, \text{UD0} \sim \text{UD7}, \text{LD0} \sim \text{LD7}$

Note 2 LCM should be grounded during handling

### (2) ENVIRONMENTAL ABSOLUTE MAXIMUM RATINGS

ITEM	NORMAL TEMP.			
	OPERATING		STORAGE	
	MIN.	MAX.	MIN.	MAX.
Ambient Temperature	0	50	-20	70
Humidity (Without Condensation)	Note 1,3		Note 2,3	
Vibration	Note 4			

Note 1  $T_a \leq 50^\circ\text{C}$  : 85%RH max

$T_a > 50^\circ\text{C}$  : Absolute humidity must be lower than the humidity of 85%RH at  $50^\circ\text{C}$

Note 2  $T_a$  at  $-20^\circ\text{C}$  will be < 48 hrs, at  $70^\circ\text{C}$  will be < 120 hrs

Note 3 Background color will change slightly depending on ambient temperature. This phenomenon is reversible.

Note 4

Frequency	5 Hz~13.95 Hz	13.95 Hz~33 Hz	33 Hz~51 Hz	51 Hz~500 Hz
Vibration Level	-	$2 \times 9.8 \text{ m/s}^2$	-	$5 \times 9.8 \text{ m/s}^2$
Vibration Width	0.2 inch	-	0.036 inch	-
Vibration Direction	X/Y/Z			
Vibration Time	20 min X 3 directions			

## 3. ELECTRICAL CHARACTERISTICS

### 3-1. ELECTRICAL CHARACTERISTICS OF LCM

(VDD = 3.3V±5%)

ITEM	SYMBOL	CONDITION		MIN.	TYP.	MAX.	UNIT
Input Voltage	VIH	VDD = 3.3V		0.7VDD	—	VDD	V
	VIL	VDD = 3.3V		0	—	0.3VDD	V
Recommended LC Driving Voltage	Vop	Duty= 1/240	0°C	24.2	24.5	24.8	V
			25°C	23.0	23.3	23.6	
		Bias= 1/13	50°C	21.5	21.8	22.1	
Power Supply Current	IDD	VDD=3.3V		—	100	150	mA

## 3-2.ELECTRICAL CHARACTERISTICS OF BACKLIGHT

CCFL Rating

Temp.=25°C

ITEM	SYMBOL	MIN.	TYP.	MAX.	UNIT	REMARK
Lamp voltage	V <sub>L</sub>	-	360	-	Vrms	-
Lamp current	I <sub>L</sub>	2.9	3.0	3.1	mArms	(*1)
Lamp power consumption	P <sub>L</sub>	-	1.1	-	W	(*2)
Starting voltage	V <sub>S</sub>	-	-	580	Vrms	-
Lamp frequency	F <sub>L</sub>	36	44	52	KHz	-
Lamp life time	L <sub>L</sub>	-	20000	-	hrs	I <sub>L</sub> = 3.0 mArms

(\*1) It is recommended that I<sub>L</sub> be not more than 3.1 mArms so that heat radiation of CCFT backlight may least affect the display quality .

(\*2) Power consumption excluded inverter loss .

## 4. OPTICAL CHARACTERISTICS

### 4-1. OPTICAL CHARACTERISTICS OF LCM

AT V<sub>OP</sub>

ITEM  MODE		Cr(Contrast Ratio)						$\theta$ (Viewing Angle)		$\phi$ (Viewing Angle)	
		0℃		25℃		50℃		25℃		25℃	
		MIN.	TYP.	MIN.	TYP.	MIN.	TYP.	MIN.	TYP.	MIN.	TYP.
T	Y	13	15	35	40	5	6	-	45-50	-	±40
Note		NOTE 6						NOTE 5			

Note:

T: Transmission

Y: Special Polarizer, 12 O'clock

AT  $\phi=0^\circ$   $\theta=0^\circ$

ITEM	SYMBOL	CONDITION	MIN.	TYP.	MAX.	UNIT	NOTE
Response Time (rise)	Tr	0℃	280	350	420	ms	NOTE 2
		25℃	160	210	260		
		50℃	70	85	100		
Response Time (fall)	Tf	0℃	400	520	630	ms	NOTE 2
		25℃	80	100	150		
		50℃	40	55	70		

(NOTE 1)

Definition of Operation Voltage(Vop)

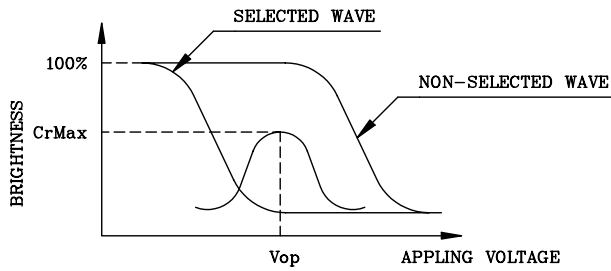

(positive type)

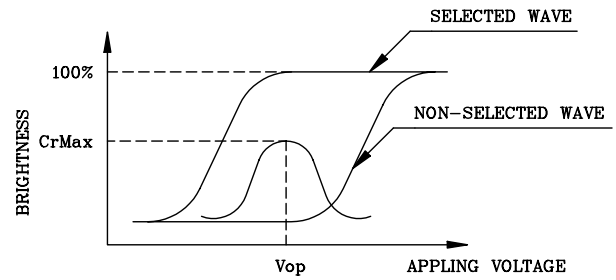

(negative type)

\*Conditions

- Viewing Angle : 0
- Frame Frequency : 70Hz
- Applying Waveform : 1/N duty 1/a bias

(NOTE 2)

Definition of Response Time(Tr,Tf)

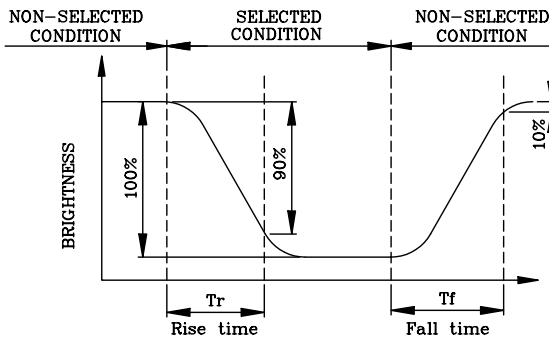

(positive type)

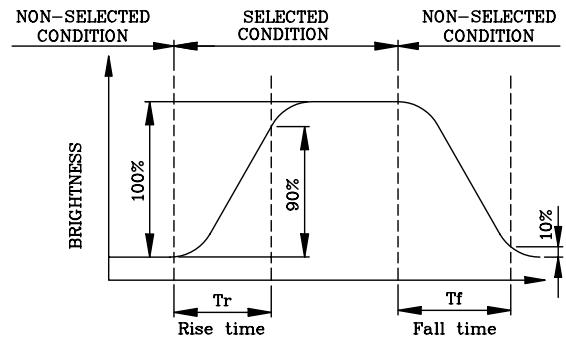

(negative type)

\*Conditions

- Operating Voltage : Vop
- Viewing Angle (θ,θ) : (0,0)
- Frame Frequency : 70Hz
- Applying Waveform : 1/N duty 1/a bias

(NOTE 3)

Description of Measuring Equipment and Driving Waveforms

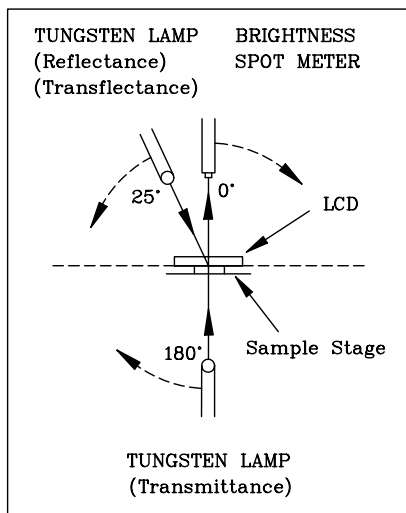

The voltage relationship of each signal is as follow  
Multiplex Driving (1/N duty 1/a bias)

Segment voltage	Segment Waveform	Common Waveform	Common voltage
V0	[Square wave]	[Pulse]	Vop
V1			
VM	[Square wave]	[Pulse]	Vop
VL			
	Normally display period	Off-display period	

(NOTE 4)

Definition of Viewing Direction

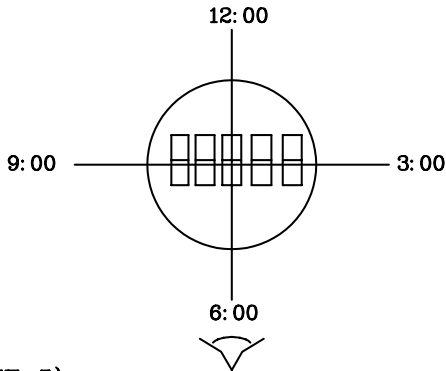

(NOTE 5)

Definition of Viewing Angle

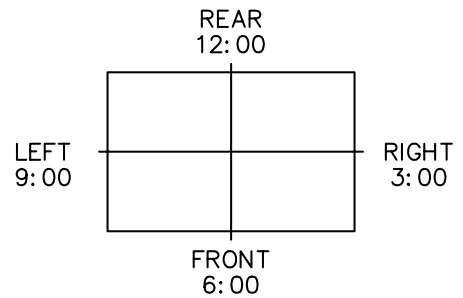
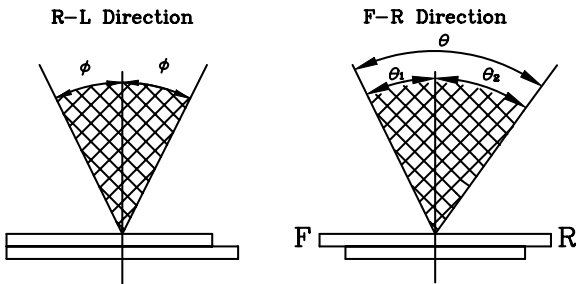

\*For This Product  
The Viewing Direction Is 6 O'clock  
So  $\theta_1 > \theta_2$

$$\theta = \theta_1 + \theta_2$$

\*Conditions

- Operating Voltage :  $V_{op}$
- Frame Frequency : 70Hz
- Applying Waveform : 1/N duty 1/a bias
- Contrast Ratio : larger than 2

(NOTE 6)

Definition of Contrast Ratio (Cr)

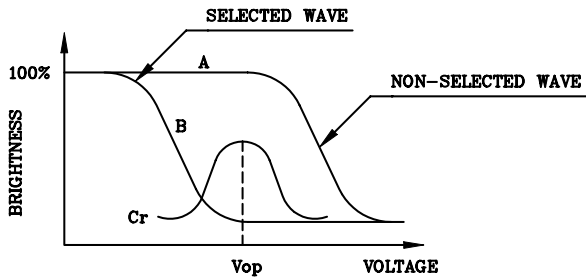

(positive type)

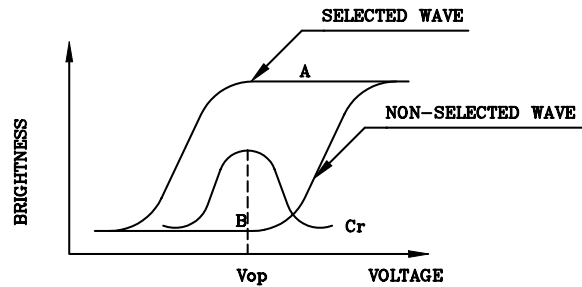

(negative type)

$$\text{Contrast Ratio : } Cr = A/B$$

\*Conditions

- Viewing Angle : 0
- Frame Frequency : 70Hz
- Applying Waveform : 1/N duty 1/a bias

## 5. BLOCK DIAGRAM

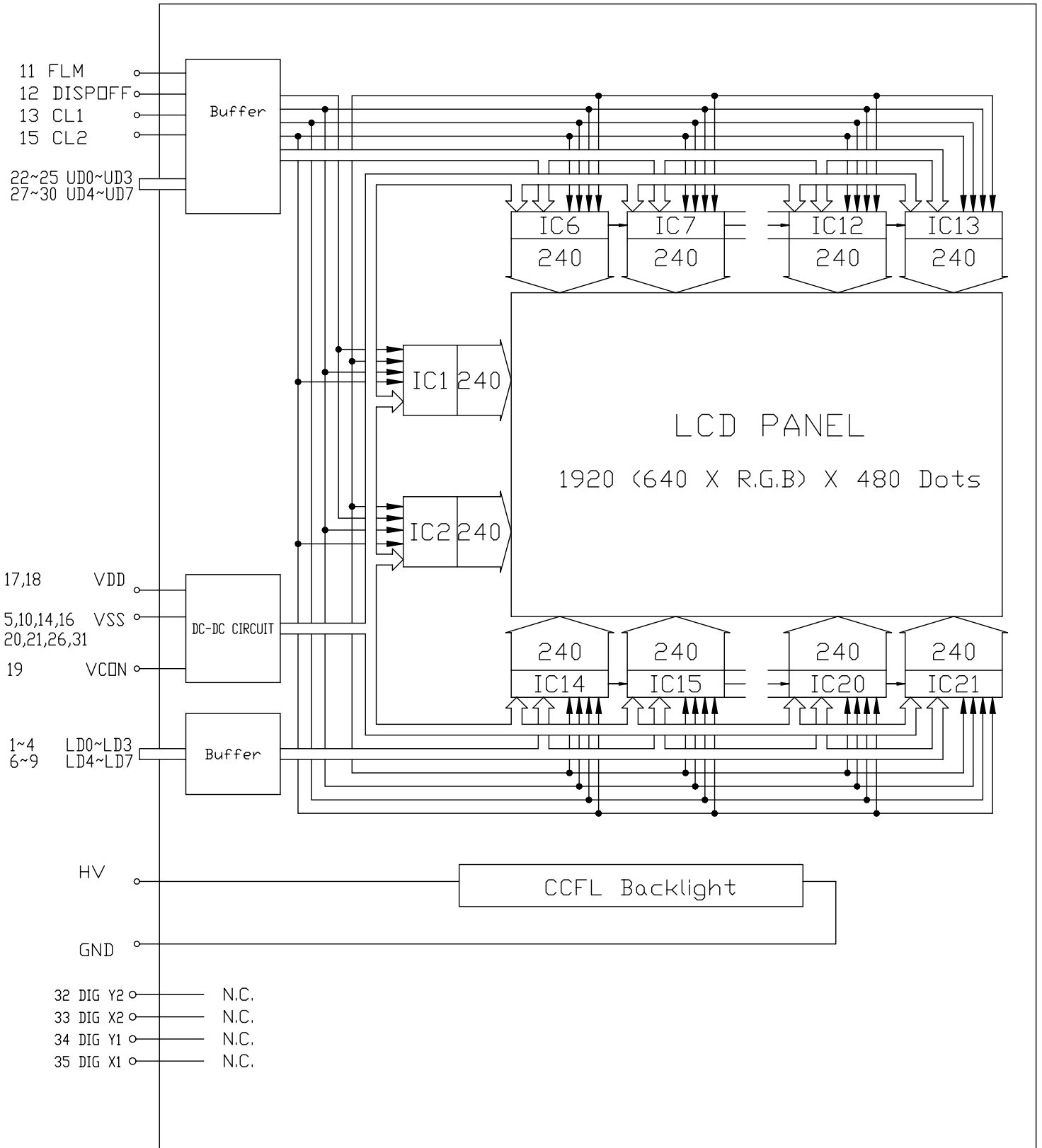



## 6. INTERNAL PIN CONNECTION

### INTERNAL PIN CONNECTION

CN1 MOLEX 54104-3511

PIN NO	SYMBOL	FUNCTION
1	LD0	Display Data (Lower Column)
2	LD1	Display Data (Lower Column)
3	LD2	Display Data (Lower Column)
4	LD3	Display Data (Lower Column)
5	VSS	GND
6	LD4	Display Data (Lower Column)
7	LD5	Display Data (Lower Column)
8	LD6	Display Data (Lower Column)
9	LD7	Display Data (Lower Column)
10	VSS	GND
11	FLM	First Line Marker
12	DISP.OFF	H : ON / L : OFF
13	CL1	Data Latch
14	VSS	GND
15	CL2	Data Shift
16	VSS	GND
17	VDD	Power Supply for Logic
18	VDD	Power Supply for Logic
19	VCON	Contrast Adjust
20	VSS	GND
21	VSS	GND
22	UDO	Display Data (Lower Column)
23	UD1	Display Data (Lower Column)
24	UD2	Display Data (Lower Column)
25	UD3	Display Data (Lower Column)
26	VSS	GND
27	UD4	Display Data (Lower Column)
28	UD5	Display Data (Lower Column)
29	UD6	Display Data (Lower Column)
30	UD7	Display Data (Lower Column)
31	VSS	GND
32	DIG Y2	NC
33	DIG X2	NC
34	DIG Y1	NC
35	DIG X1	NC

CN2 JST: BHSR-02VS-1 / Suitable Connector: SM02B-BHSS-1-TB

PIN NO	SYMBOL	FUNCTION
1	VCFL	Power Supply for CFL
2	VSS	GND for CFL

## 7. POWER SUPPLY

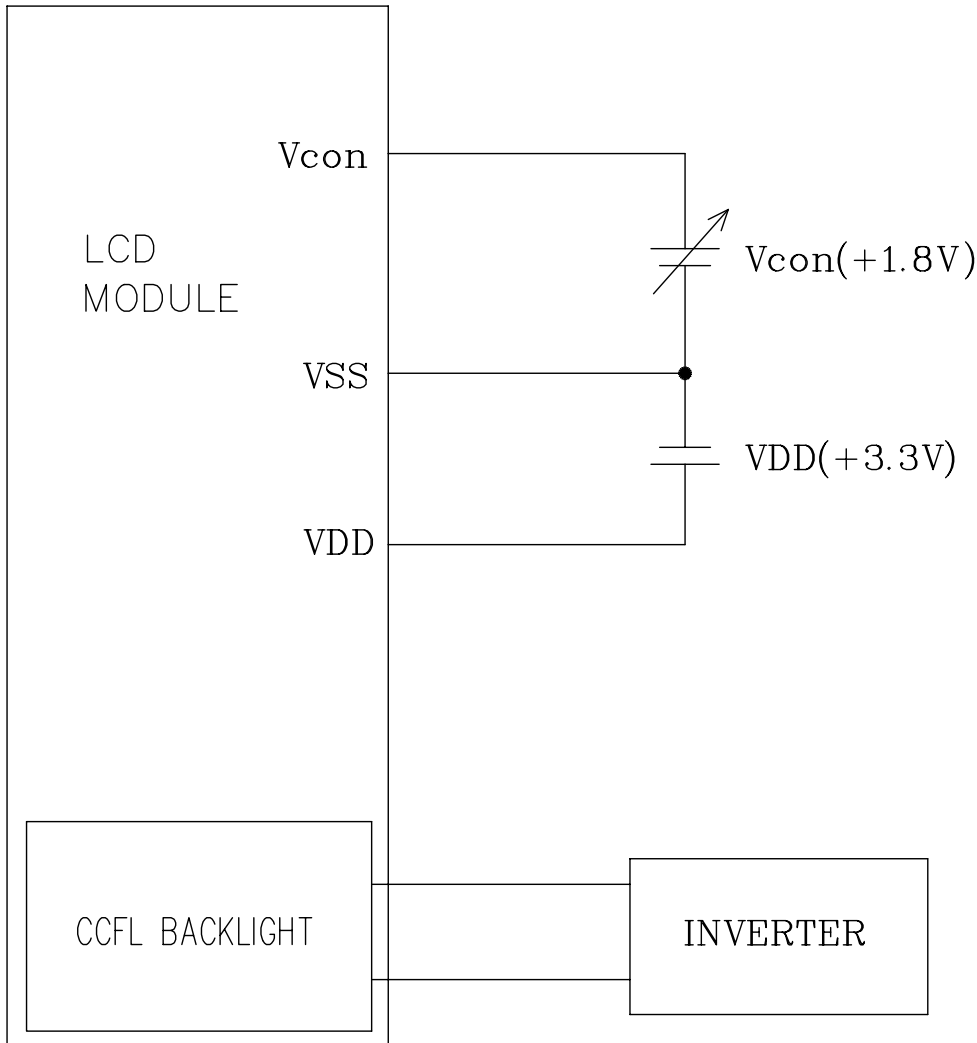

## 8. TIMING CHARACTERISTICS

### 8-1. INTERFACE TIMING

VDD=3.3V

Parameter	SYMBOL	MIN.	MAX.	UNIT
CLOCK CYCLE TIME	$t_{cyc}$	40	—	ns
CLOCK HIGH LEVEL WIDTH (1)	$t_{cwh2}$	15	—	ns
CLOCK LOW LEVEL WIDTH (1)	$t_{cwl2}$	15	—	ns
CLOCK HIGH LEVEL WIDTH (2)	$t_{cwh1}$	30	—	ns
CLOCK SETUP TIME	$t_{scl}$	20	—	ns
CLOCK HOLD TIME	$t_{hcl}$	50	—	ns
CLOCK RISE TIME	$t_r$	—	30	ns
CLOCK FALL TIME	$t_f$	—	30	ns
DATA SETUP TIME	$t_{ds}$	10	—	ns
DATA HOLD TIME	$t_{dh}$	10	—	ns
M SETUP TIME	$t_{ms}$	20	—	ns
M HOLD TIME	$t_{mh}$	20	—	ns

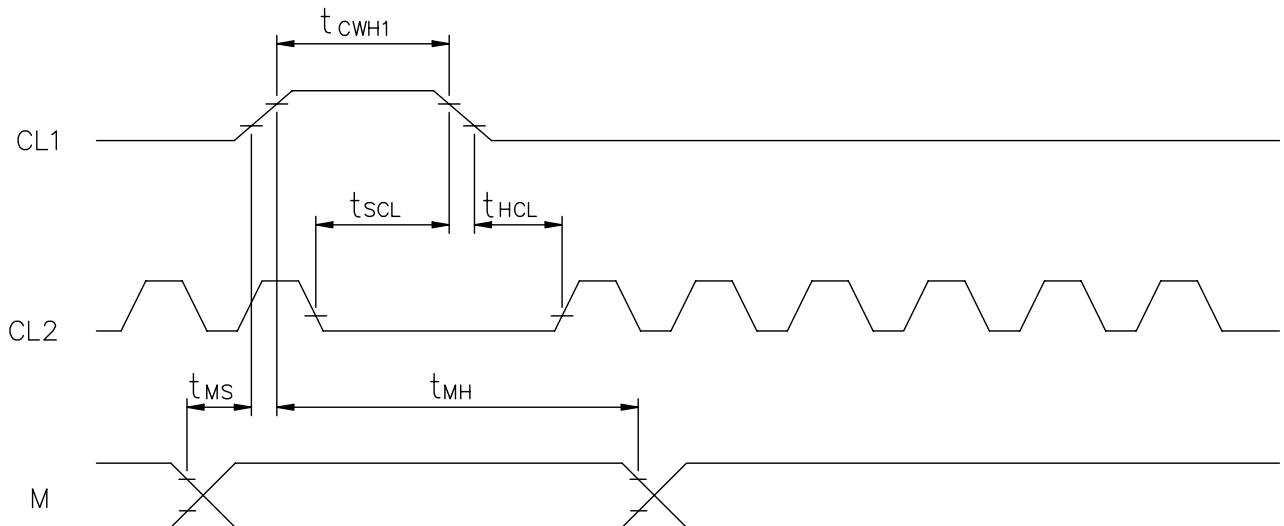
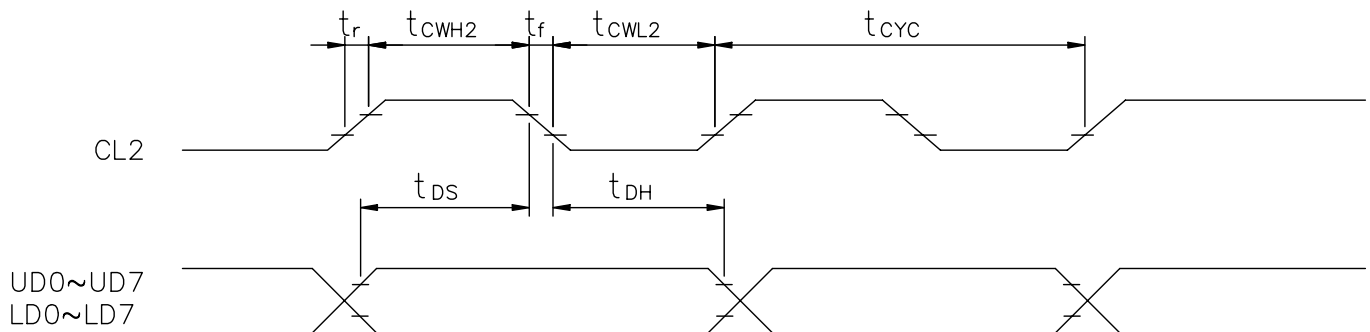

## 8-2 POWER ON/OFF TIMING

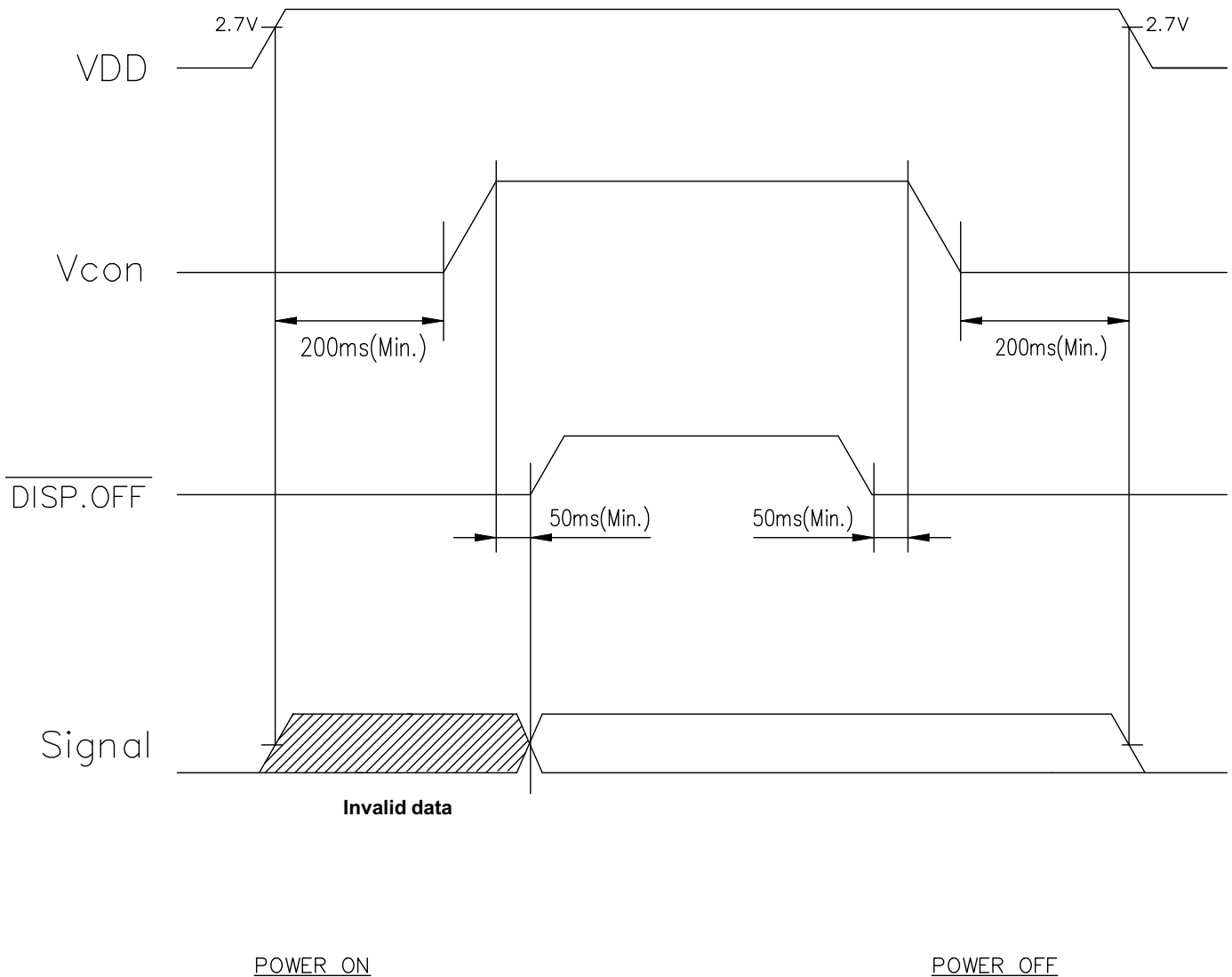

Missing pixels may occur when the LCM is driven beyond the above power interface timing sequence.

## 8-3. DISPLAY SEQUENCE

	Y1			Y2		
X1	R1	G1	B1	R2	G2	B2
X2	R1	G1	B1	R2	G2	B2

	Y639			Y640		
	R639	G639	B639	R640	G640	B640
	R639	G639	B639	R640	G640	B640

X479	R1	G1	B1	R2	G2	B2
X480	R1	G1	B1	R2	G2	B2

	R639	G639	B639	R640	G640	B640
	R639	G639	B639	R640	G640	B640

INTERNAL PIN CONNECTION  
CNI MOLEX 54104-3511

PIN NO	SYMBOL	FUNCTION
1	LD0	Display Data (Lower Column)
2	LD1	Display Data (Lower Column)
3	LD2	Display Data (Lower Column)
4	LD3	Display Data (Lower Column)
5	VSS	GND
6	LD4	Display Data (Lower Column)
7	LD5	Display Data (Lower Column)
8	LD6	Display Data (Lower Column)
9	LD7	Display Data (Lower Column)
10	VSS	GND
11	FLM	First Line Marker
12	DISP.OFF	H : ON / L : OFF
13	CL1	Data Latch
14	VSS	GND
15	CL2	Data Shift
16	VSS	GND
17	VDD	Poewr Supply for Logic
18	VDD	Poewr Supply for Logic
19	VCON	Contrast Adjust
20	VSS	GND
21	VSS	GND
22	UD0	Display Data (Lower Column)
23	UD1	Display Data (Lower Column)
24	UD2	Display Data (Lower Column)
25	UD3	Display Data (Lower Column)
26	VSS	GND
27	UD4	Display Data (Lower Column)
28	UD5	Display Data (Lower Column)
29	UD6	Display Data (Lower Column)
30	UD7	Display Data (Lower Column)
31	VSS	GND
32	DIG Y2	NC
33	DIG X2	NC
34	DIG Y1	NC
35	DIG X1	NC

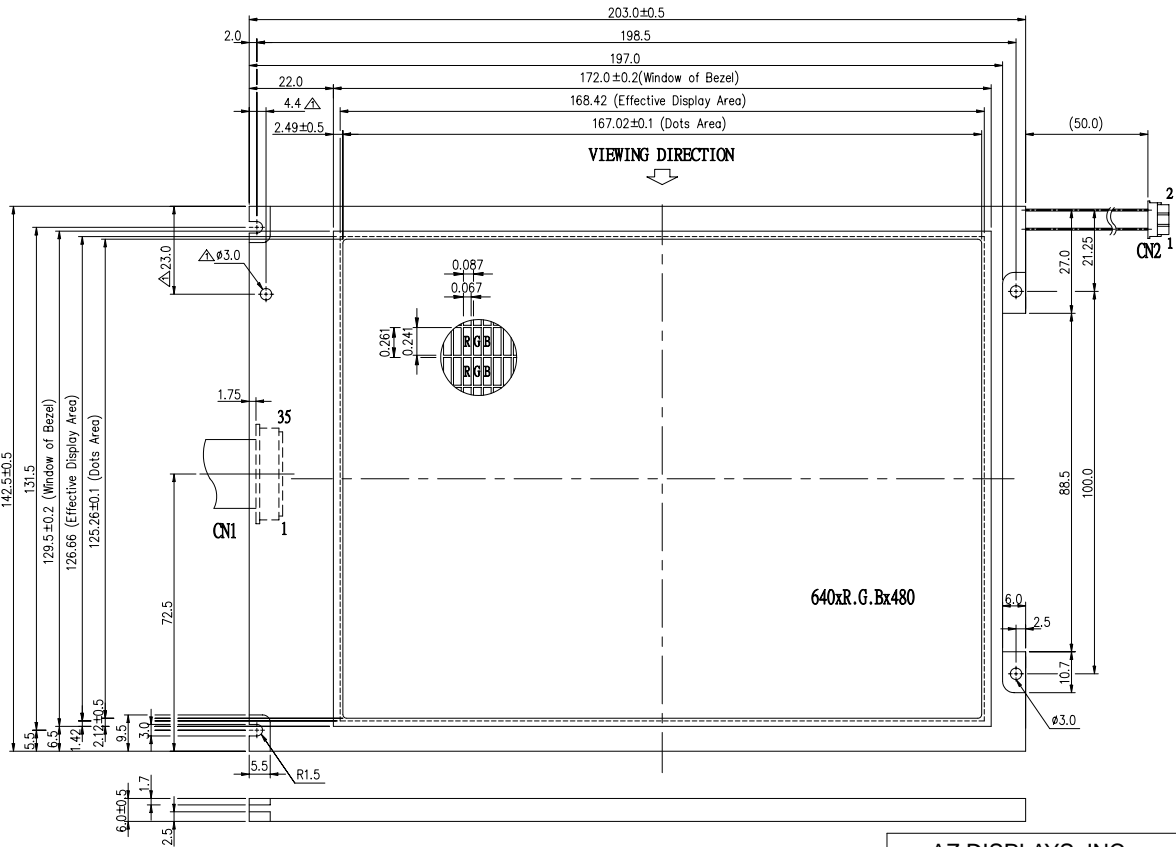

CNI 1ST: BHSR-02VS-1 / Suitable Connector: SM02B-BHSS-1-TB

PIN NO	SYMBOL	FUNCTION
1	VCFL	Power Supply for CFL
2	VSS	GND for CFL

NOTE:

1. RESOLUTION: 640xR.G.B.x480
2. BACKLIGHT: CCFL
3. ALL DIMENSIONAL TOLERANCE  $\pm 0.5$  UNLESS OTHERWISE SPECIFIED

AZ DISPLAYS, INC.

AGM6448T

REV. NO.	DESCRIPTION	DATE	DESIGN	CHECK	APPROVE	DWG NO.
△						
△						
△						
△	增加部份尺寸	00.06.11	J.H.SUN			

APPROVE	NAME	DATE	THIRD ANGLE P
△	J.H.SUN	89.04.12	☉
△	J.H.SUN	89.04.11	☉
△	J.H.SUN	89.03.27	SCALE UNIT
△	J.H.SUN	89.03.27	1/1 mm

M379-1D1A