

AZ DISPLAYS, INC.

Complete LCD Solutions

AGM6448V Series LCD Module

1. MECHANICAL DATA

(1) Product No.	AGM6448V
(2) Module Size	264.0 (W)mm x 183.0 (H)mm x MAX 9.0 (D)mm
(3) Dot Size	0.09 (W)mm x 0.31 (H)mm
(4) Dot Pitch	0.11 (W)mm x 0.33 (H)mm
(5) Number of Dots	640 (W)xRGB x 480 (H)DOTS
(6) Duty	1/240
(7) LCD	F-STN/Black and White(Normal Black/Negative Image) /Color Transmissive Type
(8) Viewing Direction	6 O'clock
(9) Backlight	CCFL
(10) Controller	Without
(11) DC/DC Converter	Without
(12) Weight	495 g(approx.)
(13) Recommended CCFT Inverter	CXA-L0612-VMR (TDK)

2. ABSOLUTE MAXIMUM RATINGS

VSS=0V

ITEM	SYMBOL	MIN	MAX	UNIT	COMMENT
Power Supply for Logic	VDD-VSS	-0.3	6.5	V	
Power Supply for LCD Drive	VEE-VSS	0	42.0	V	
Input Voltage	VI	-0.3	VDD+0.3	V	
Static Electricity	-	-	-	-	Note 1

Note 1 LCM should be grounded during handling LCM.

AZ DISPLAYS, INC.

Complete LCD Solutions

3. ELECTRICAL CHARACTERISTICS

3.1 ELECTRICAL CHARACTERISTICS OF LCM

ITEM	SYMBOL	CONDITION		MIN.	TYP.	MAX.	UNIT
Logic Circuit Power Supply	VDD-VSS	Ta= 25°C		4.5	5.0	5.5	V
Input Voltage	VIH	H level		0.8VDD	-	VDD	V
	VIL	L level		0	-	0.2VDD	V
Recommended LCD Driving Voltage (Normal Temp. LCM)	VEE-VSS	Duty=1/240 Bias=1/13 VDD=5.0V	0°C	-	24.1	24.2	V
			25°C	23.3	23.5	23.6	
			50°C	22.6	22.8	23.0	
Supply Current for Logic	IDD	VDD-VSS = 5.0V VEE-VSS = 23.5V Ta= 25°C		-	18.8	28.5	mA
Supply Current for LCD	IEE			-	8.0	12.5	mA

3.2 ELECTRICAL CHARACTERISTICS OF BACKLIGHT

Used lamp : Rating

PARAMETER	SYMBOL	MIN.	TYP.	MAX.	UNIT	REMARK
Lamp Voltage	V _L	-	535		Vrms	-
Lamp current	I _L	4	5	6	mArms	(*1)
Lamp power consumption	P _L	-	2.7	-	W	(*2)
Lamp frequency	F _L	-	35	-	kHz	
Starting voltage	V _S	-	-	600	Vrms	Ta=25°C
Color Coordinates	X	0.27	0.29	0.31	-	
	Y	0.27	0.29	0.31		
Brightness	B	22000	-	-	cd/m ²	
Lamp life time	L _L	10000	-	-	hrs	

(*1) It is recommended that I be not more than 5.0 mArms so that heat radiation of CCFT backlight may least affect the display quality .

(*2) Power consumption excludes inverter loss .

LCM : Rating

PARAMETER	SYMBOL	MIN.	TYP.	MAX.	UNIT	REMARK
Surface Luminance	L	-	76	-	cd/m ²	
Luminance Uniformity	Lu	-	85	-	%	White

AZ DISPLAYS, INC.

Complete LCD Solutions

4.OPTICAL CHARACTERISTICS

4-1 Optical Characteristics of Normal Temp. Mode

AT V_{OP}

ITEM		Cr(Contrast Ratio)		θ (Viewing Angle)		0 (Viewing Angle)	
		25°C		25°C		25°C	
		MIN.	TYP.	MIN.	TYP.	MIN.	TYP.
T	G	15	30	50			45

T: TRANSMISSIVE
G: NORMALLY BLACK

AT θ=0° 0=0°

ITEM	SYMBOL	CONDITION	MIN.	TYP.	MAX.	UNIT	NOTE
Response Time (rise)	Tr	0°C	-	210	400	ms	NOTE 2
		25°C	-	150	280		
		50°C	-	100	200		
Response Time (fall)	Tf	0°C	-	250	500	ms	NOTE 2
		25°C	-	170	340		
		50°C	-	120	240		

AZ DISPLAYS, INC.

Complete LCD Solutions

5. BLOCK DIAGRAM

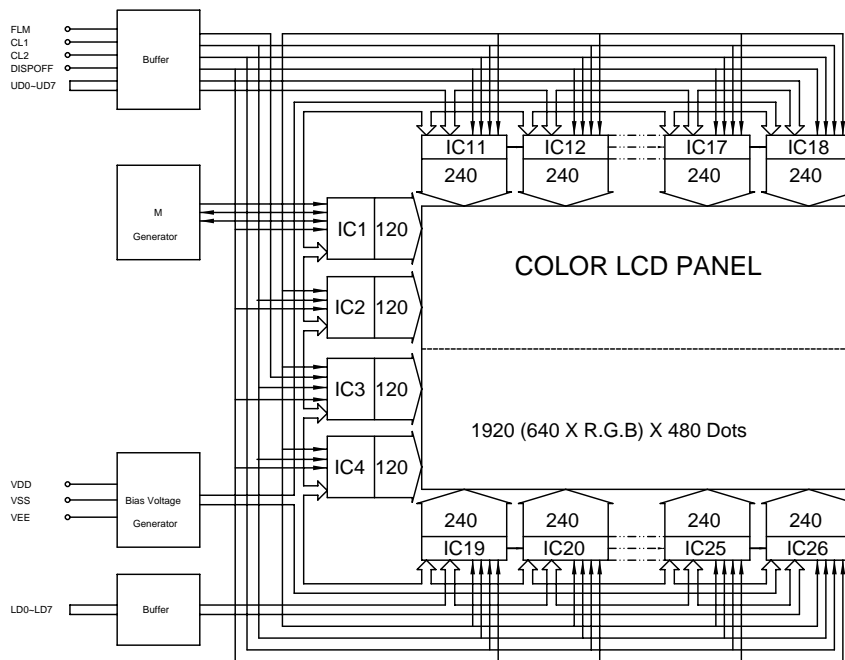

AZ DISPLAYS, INC.

Complete LCD Solutions

6.INTERFACE PIN CONNECTION

CN3:30PIN JAE/IL-402-30S-S1L-SA

CN1:15PIN MOLEX 53261-1590

CN2:14PIN MOLEX 53261-1490

INTERFACE	PIN NO.	SYMBOL	FUNCTION	PIN NO.	
LCM	CN3	1	FLM	The FLM signal indicates the beging of each display cycle.	1
		2	NC		2
		3	DISPOFF	H ---display ON, L --display OFF	3
		4	CL1	The CL1 latches the serial data in the shift registers.	4
		5	VSS	GND	5
		6	CL2	Clock signal for shifting the serial data.	6
		7	VSS	GND	7
		8	UD0	Display data for upper column driver	8
		9	UD1	Display data for upper column driver	9
		10	UD2	Display data for upper column driver	10
		11	UD3	Display data for upper column driver	11
		12	UD4	Display data for upper column driver	12
		13	UD5	Display data for upper column driver	13
		14	UD6	Display data for upper column driver	14
		15	UD7	Display data for upper column driver	15
		16	LD0	Display data for lower column driver	1
		17	LD1	Display data for lower column driver	2
		18	LD2	Display data for lower column driver	3
		19	LD3	Display data for lower column driver	4
		20	LD4	Display data for lower column driver	5
		21	LD5	Display data for lower column driver	6
		22	LD6	Display data for lower column driver	7
		23	LD7	Display data for lower column driver	8
		24	VDD	+5V	9
		25	VSS	GND	10
		26	VSS	GND	11
		27	VEE	Power supply voltage for LCD (+)	12
		28	VEE	Power supply voltage for LCD (+)	13
		29	VEE	Power supply voltage for LCD (+)	14
		30	NC		

FLCN1:MITSUMI/M63M83-04

(Suitable Connector:MITSUMI/M60-04-30-134P or M60-04-30-114P or M61M73-04)

INTERFACE	PIN NO.	SYMBOL	FUNCTION
CFL	FLCN1	1	GND
		2	N.C
		3	N.C
		4	HV

AZ DISPLAYS, INC.

Complete LCD Solutions

7.POWER SUPPLY

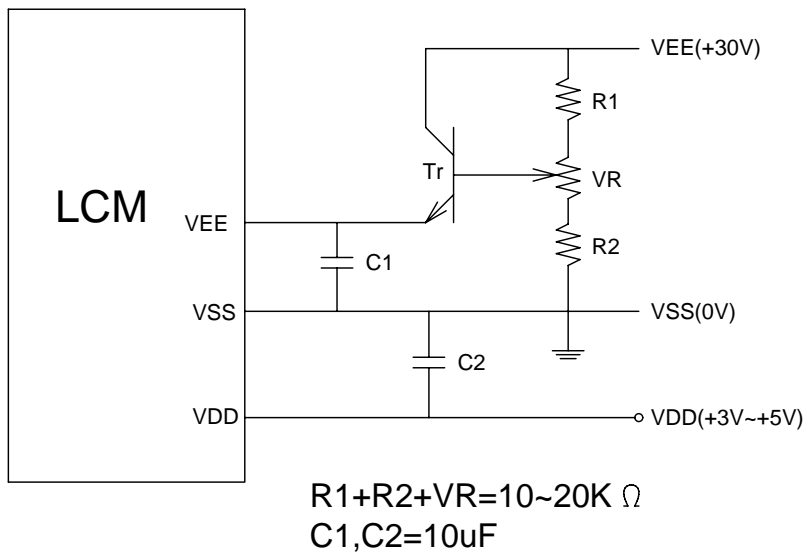

AZ DISPLAYS, INC.

Complete LCD Solutions

8.TIMING CHARACTERISTICS

8-1.INTERFACE TIMING

VDD=5.0V ± 10%

Parameter	SYMBOL	MIN.	MAX.	UNIT
CLOCK PULSE CYCLE TIME	t_{WCK}	50	-	ns
CLOCK PULSE HIGH LEVEL WIDTH	t_{WCKH}	15	-	ns
CLOCK PULSE LOW LEVEL WIDTH	t_{WCKL}	15	-	ns
LATCH PULSE HIGH LEVEL WIDTH	t_{WLPH}	20	-	ns
CP → LP RISE TIME	t_{LD}	0	-	ns
CP → LP FALL TIME	t_{SL}	25	-	ns
LP → CP RISE TIME	t_{LS}	25	-	ns
LP → CP FALL TIME	t_{LH}	25	-	ns
CLOCK PULSE RISE/FALL TIME	t_r, t_f	-	30	ns
DATA SETUP TIME	t_{DS}	10	-	ns
DATA HOLD TIME	t_{DH}	10	-	ns
FLM SETUP TIME	t_{SU}	100	-	ns
FLM HOLD TIME	t_H	30	-	ns

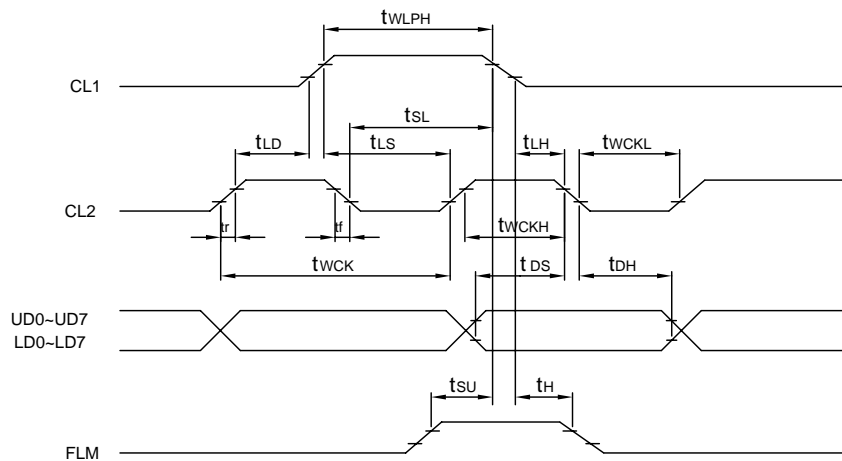

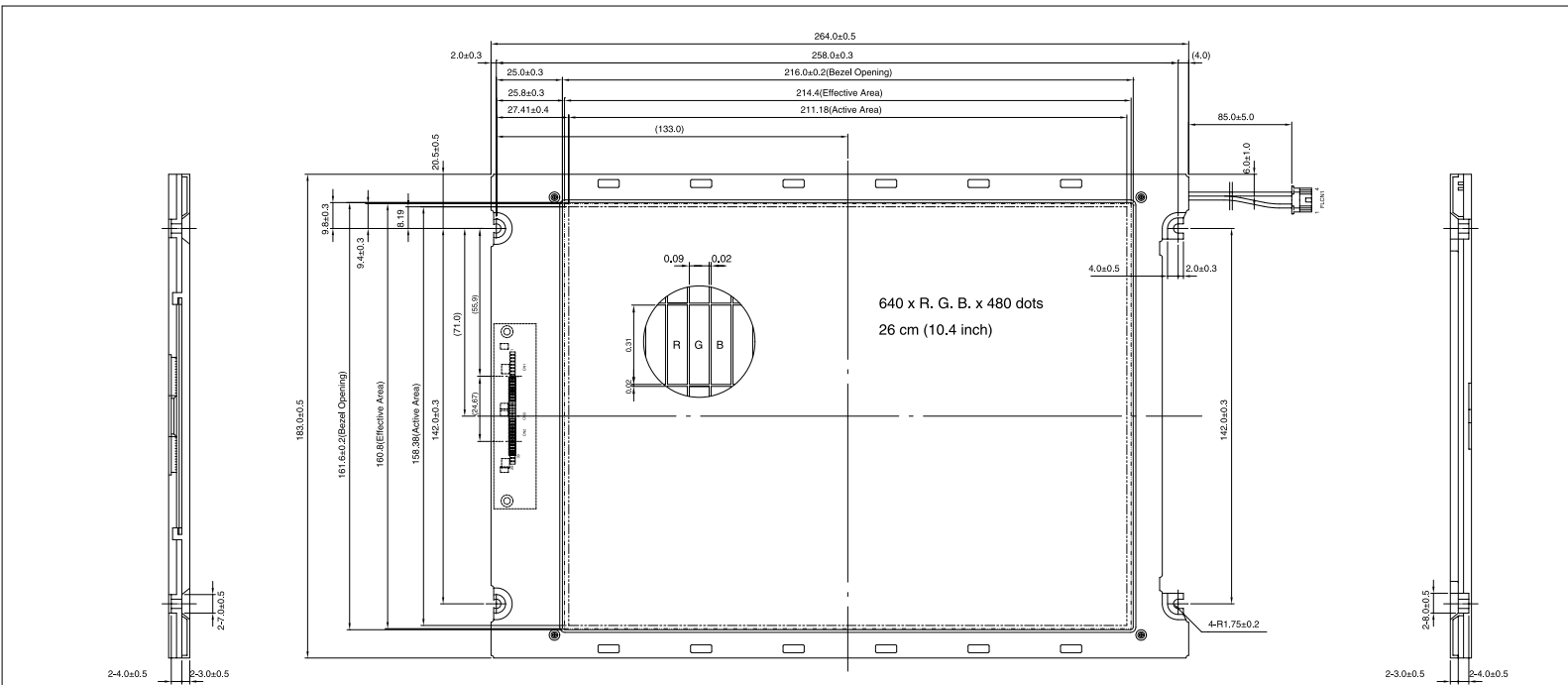

PIN NO.	SYMBOL	FUNCTION	PIN NO.
1	FLM	The FLM signal indicates the beginning of each display cycle.	1
2	NC		2
3	DISP OFF	H—display ON, L—display OFF	3
4	CL1	The CL1 latches the serial data in the shift registers.	4
5	VSS	GND	5
6	CL2	Clock signal for shifting the serial data.	6
7	VSS	GND	7
8	UD0	Display data for upper column driver	8
9	UD1	Display data for upper column driver	9
10	UD2	Display data for upper column driver	10
11	UD3	Display data for upper column driver	11
12	UD4	Display data for upper column driver	12
13	UD5	Display data for upper column driver	13
14	UD6	Display data for upper column driver	14
15	UD7	Display data for upper column driver	15
16	LD0	Display data for lower column driver	1
17	LD1	Display data for lower column driver	2
18	LD2	Display data for lower column driver	3
19	LD3	Display data for lower column driver	4
20	LD4	Display data for lower column driver	5
21	LD5	Display data for lower column driver	6
22	LD6	Display data for lower column driver	7
23	LD7	Display data for lower column driver	8
24	VDD	+5V	9
25	VSS	GND	10
26	VSS	GND	11
27	VEE	Power supply voltage for LCD (+)	12
28	VEE	Power supply voltage for LCD (+)	13
29	VEE	Power supply voltage for LCD (+)	14
30	NC		

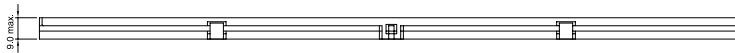

CN3 : 30PIN JAE/IL-402-30S-S1L-SA
 FLCN1 : M63M83-04(MITSUMI)

CN1 : 15PIN MOLEX 53261-1590
 CN2 : 14PIN MOLEX 53261-1490

	PIN NO.	SYMBOL	CFL GND	FUNCTION
FLCN1	1	GND	-	
	2	NC	-	
	3	NC	-	
	4	HV	-	Power supply voltage for CFL

					AZ DISPLAYS	
2	1				TITLE	
REVISION RECORD		DATE	NAME	MARK	DWG-NO	
APPROVE					AGM6448V	
CHECK					UNIT : mm	
DRAWN		87,07,07			SCALE : 2/4.5	
					THIRD ANGLE PROJECT	