

AZ DISPLAYS, INC.

COMPLETE LCD SOLUTIONS

SPECIFICATIONS FOR LIQUID CRYSTAL DISPLAY

PART NUMBER:

AGM6424B

DATE:

JANUARY 21, 2003

1. LCD Module

1.1 Main Data

No.	Item	Contents	Unit
(1)	Module size	173.0(W) x 73.0(H) x 7.0(D)	mm
(2)	Viewing area	156.0(W) x 60.0(H)	mm
(3)	Dot Number	640 x 3 (R.G.B) (W) x 240 (H)	dots
(4)	Dot Size	0.065(W) x 0.225(H)	mm
(5)	Dot pitch	0.08(W) x 0.24(H)	mm
(6)	LCD type	Color-STN (Negative type)	-
(7)	Contrast ratio	(30)	-
(8)	Duty	1/244	-
(9)	Viewing direction	6 o clock	-
(10)	Operating temperature	+0 ~ +50	C
(11)	Storage temperature	-20 ~ +70	C
(12)	Backlight	Cold Cathode Fluorescent Lamp (CCFL) x 1	pcs
(13)	Power Supply Voltage	3.3V	-
(14)	Weight	(120)	g

1.2 Interface Pin Connection

CN1 : 52893-2090(MOLEX) / Suitable FPC : Pitch 0.5mm, width 10.5mm

Pin No.	Signal	Pin Function
1	FLM	Scan start-up signal
2	V _{SS}	GND
3	CL1	Input data latch signal
4	V _{SS}	GND
5	CL2	Data shift clock
6	V _{SS}	GND
7	DISP	Display control signal H:ON , L:OFF
8	V _{DD}	Logic supply voltage
9	V _{CON}	Contrast adjust voltage
10	V _{SS}	GND
11	D0	Display data
12	D1	Display data
13	D2	Display data
14	D3	Display data
15	V _{SS}	GND
16	D4	Display data
17	D5	Display data
18	D6	Display data
19	D7	Display data
20	V _{SS}	GND

CN2 : BHSR-02VS-1 (JST) / Suitable connector : SM02B-BHSS-1-TB (JST)

Pin No.	Signal	Pin Function
1	H.V	Power supply voltage for CFL
2	GND	CFL GND

2. Block Diagram

CN1

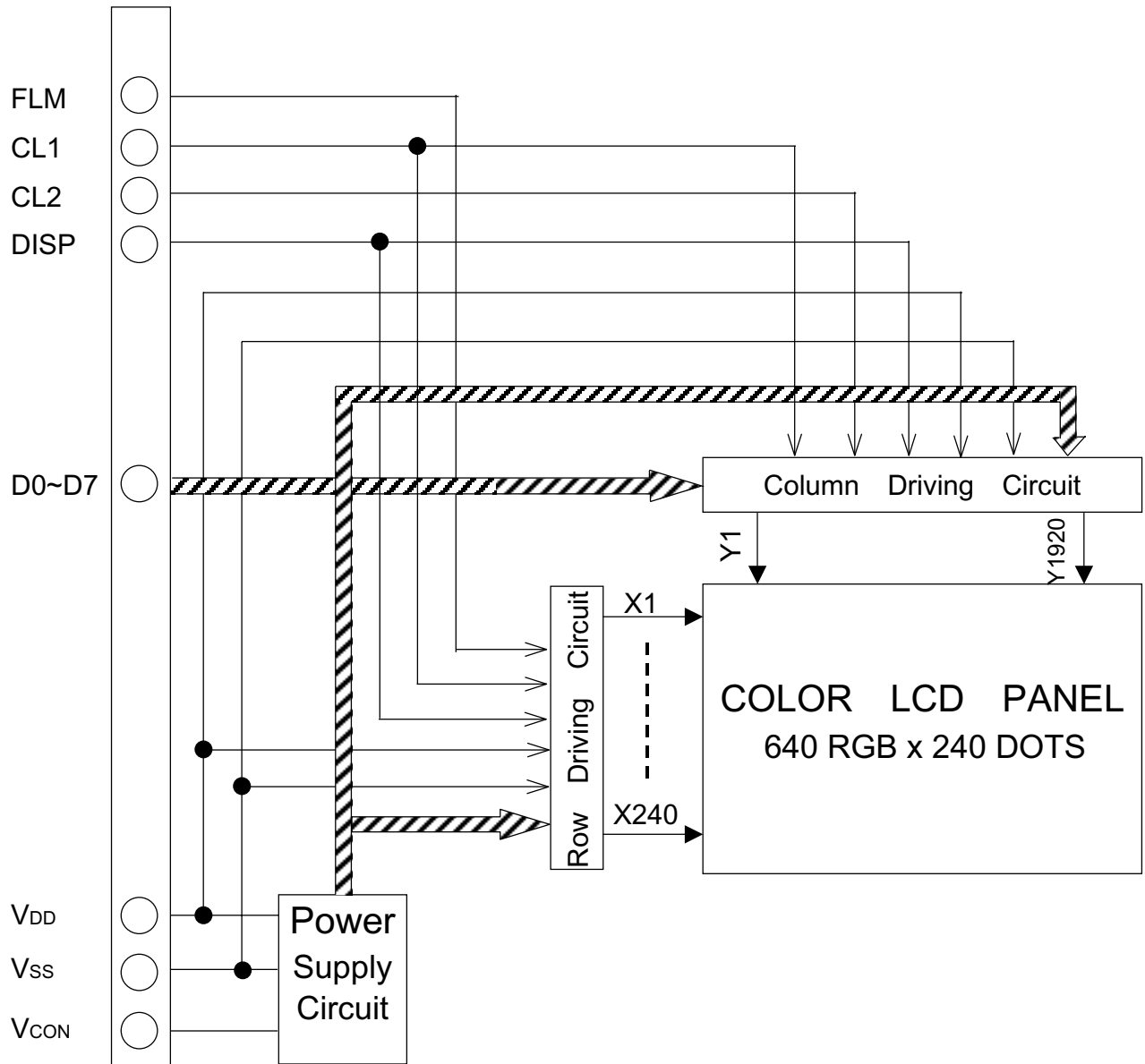

CN2

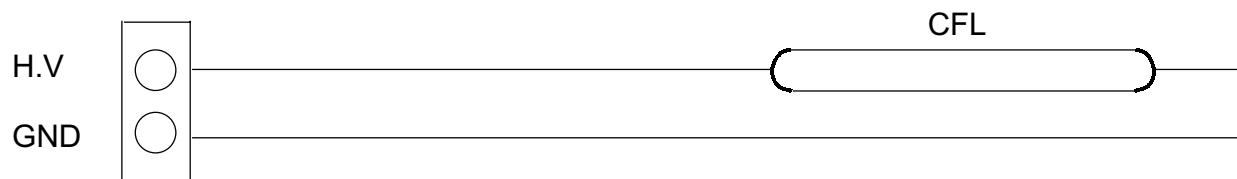

3. Maximum Ratings

3.1 Electrical Absolute Maximum Ratings. (V_{SS}=0V)

Item	Symbol	Min.	Max.	Unit
Power supply for Logic	V _{DD} -V _{SS}	-0.3	7.0	V
Input voltage (Note 1)	V _I	-0.3	V _{DD} +0.3	V

Note 1. FLM,CL1,CL2,DISP,D0~D7.

Note 2. Ta=25 C

Note 3. Please be sure users are grounded when handling the LCD module.

3.2 Environmental Absolute Maximum Ratings

Item	Storage		Operating		Remark
	MIN.	MAX.	MIN.	MAX.	
Ambient Temperature	-20 C	70 C	0 C	50 C	Note1,2,3
Humidity	Note 4		Note 4		No Condensation

Note 1. Ta at -20 C -----< 48hours, at 70 C -----< 120 hours.

Note 2. Background color changes slightly depending on ambient temperature.
This phenomenon is reversible.

Note 3. When LCM is operated at 0 C, the lifetime of the CFL will be reduced.
The response time at 0 C will increase.

Note 4. Ta<=50 C : 85%RH MAX.

Ta> 50 C : Absolute humidity must be lower than the humidity of 85% RH at 50 C.

4. Electrical Characteristics

4.1 Electrical Characteristics of LCD

Item	Symbol	Condition	MIN.	Typ.	Max.	Unit
Power Supply for Logic	V _{DD}		3.0	3.3	3.6	V
Contrast adjust voltage	V _{CON}	Note(1)	Ta= 5 C	(0.8)		V
			Ta=25 C		(1.8)	
			Ta=40 C		(2.8)	
Input Signal Voltage Note (2)	V _{IH}	H Level	0.8V _{DD}		V _{DD}	V
	V _{IL}	L Level	0		0.2V _{DD}	
Power supply current Note (3)	I _{DD}	V _{DD} =3.3V		(40)		mA
Frame Frequency Note (4)	fFLM		(60)	(75)	(90)	Hz

Note (1) The value is specified as the voltage at which the optimum contrast is obtained.

Note (2) FLM,CL1,CL2,DISP,D0~D7

Note (3) fFLM=75Hz,Ta=25 C,Display pattern is Black/White cross pattern as below.

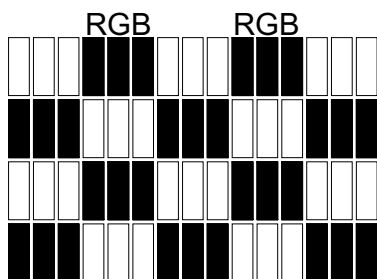

Note (4) No flicker or ripple phenomenon experienced on the display.

4.2 Electrical Characteristics of Backlight

Item	Symbol	Min.	Typ.	Max.	Unit	Remark
Starting Voltage	V _S	-	-	(1000)	V _{rms}	Ta=5 C
Lamp Voltage	V _L	-	(490)	-	V _{rms}	Ta=25 C
Frequency	f _L	40	60	80	KHz	Ta=25 C
Lamp Current	I _L	(3.0)	(3.5)	(4.0)	mA _{rms}	Ta=25 C

Note (1) Starting voltage is higher when the LCM operates at lower temperatures.

Note (2) Average lifetime of CFL will be decreased when LCM is operated at lower temperatures.

Note (3) CFL lifetime : 10000 hours Min. at I_L=3.5mA, Ta=25 C

5. Optical Characteristics

5.1 Optical Characteristics of LCD

Ta= 25°C.(Backlight On)

Item	Symbol	Condition	Min.	Typ.	Max.	Unit	Remark	
Viewing Angle Range	$\phi 1, \phi 2$	CR ≥ 2	X axis	60	-	-	Deg.	Note 1,2
			Y axis	35	-	-		
Contrast Ratio	CR	$\phi = 0^\circ$	TBD	(30)	-	-	Note 3,4	
Response Time	Rise	tr	$\theta = 0^\circ, \phi = 0^\circ$	-	(340)	-	ms	Note 5
	Fall	tf	$\theta = 0^\circ, \phi = 0^\circ$	-	(110)	-	ms	
Color Tone (CIE Coordinate)	R	x	$\theta = 0^\circ, \phi = 0^\circ$	(0.44)	(0.49)	(0.54)	-	
		y		(0.30)	(0.35)	(0.40)	-	
	G	x		(0.28)	(0.33)	(0.38)	-	
		y		(0.44)	(0.49)	(0.54)	-	
	B	x		(0.15)	(0.20)	(0.25)	-	
		y		(0.16)	(0.21)	(0.26)	-	
	W	x		(0.27)	(0.32)	(0.37)	-	
		y		(0.30)	(0.35)	(0.40)	-	

Note 1. Definition of θ and ϕ

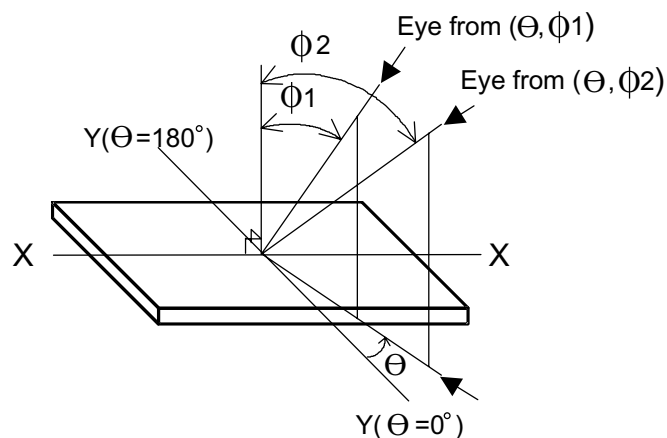

Note 2. Definition of Viewing angle $\phi 1$ and $\phi 2$

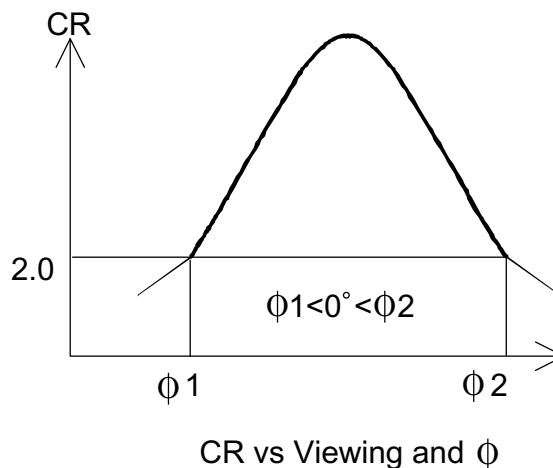

Note 3. Definition of Contrast Ratio CR

$$CR = \frac{\text{Brightness at selected dot (B1)}}{\text{Brightness at non-selected dot (B2)}}$$

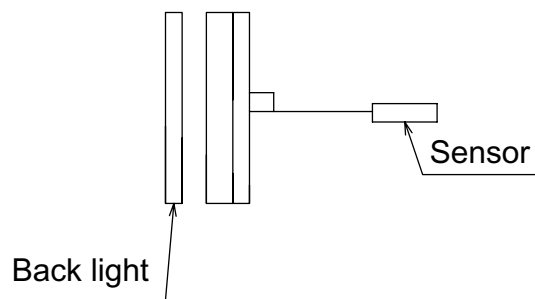
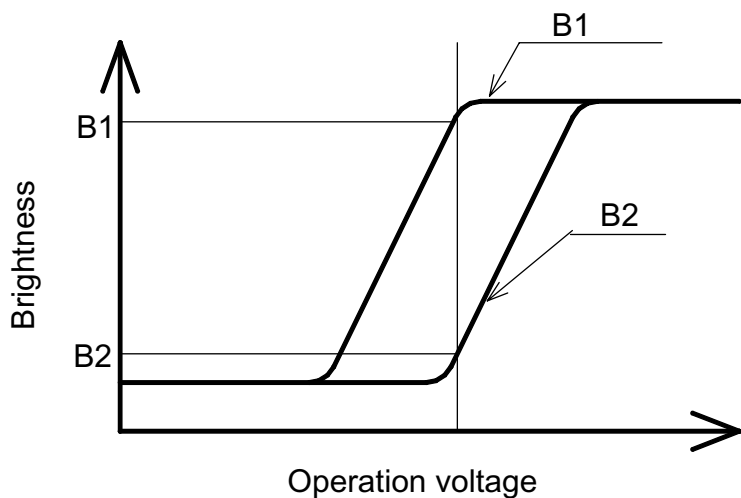

Sensor : BM-7
Aperture : 1°
Distance : 50 cm

Note 4. Definition of CR and V_{OP}

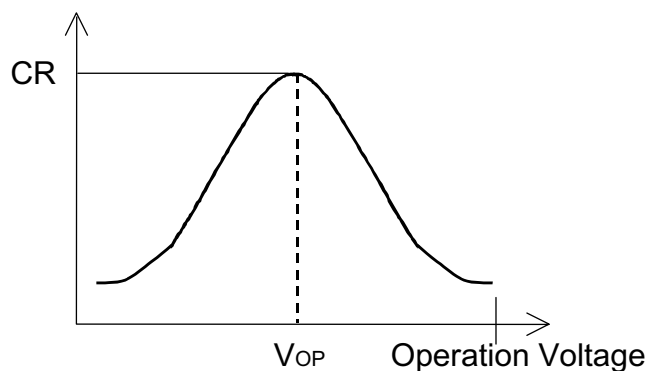

Note 5. Definition of optical response time

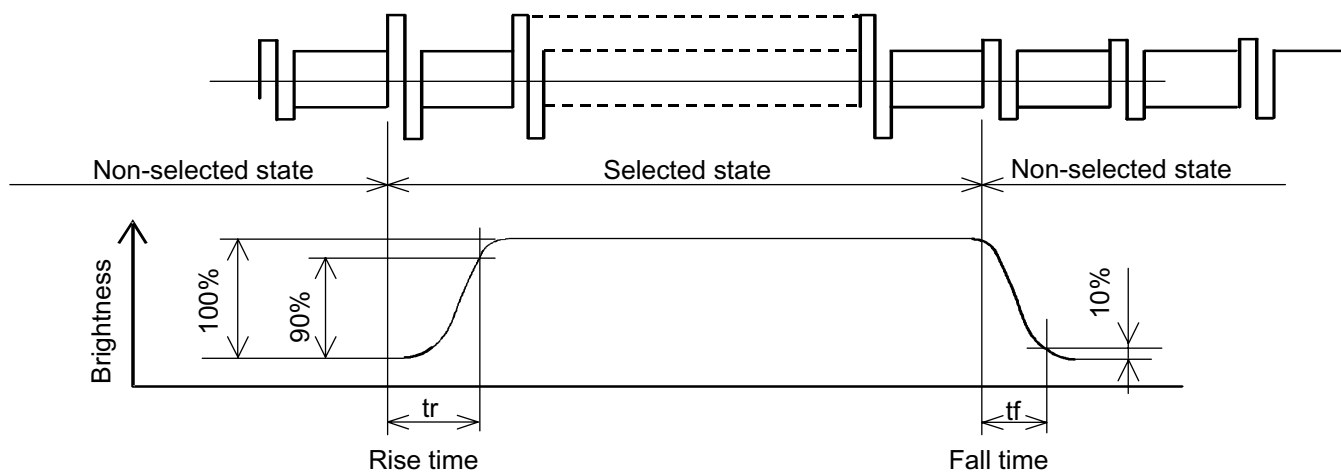

5.2 Optical Characteristics of Backlight

Item	Min,	Typ.	Max.	Unit	Remark
Brightness	-	(150)	-	cd/m ²	Note 1,2,3
Brightness Uniformity	-	-	+/-30	%	Note 2,3,4

Note 1. Measurement Condition:

Display data should be all ON (D0~D7=HIGH).

VDD=3.3V, IL=3.5mA, VCON should be adjusted at the optimum voltage

Note 2. Measured on the following 5 points of the display.

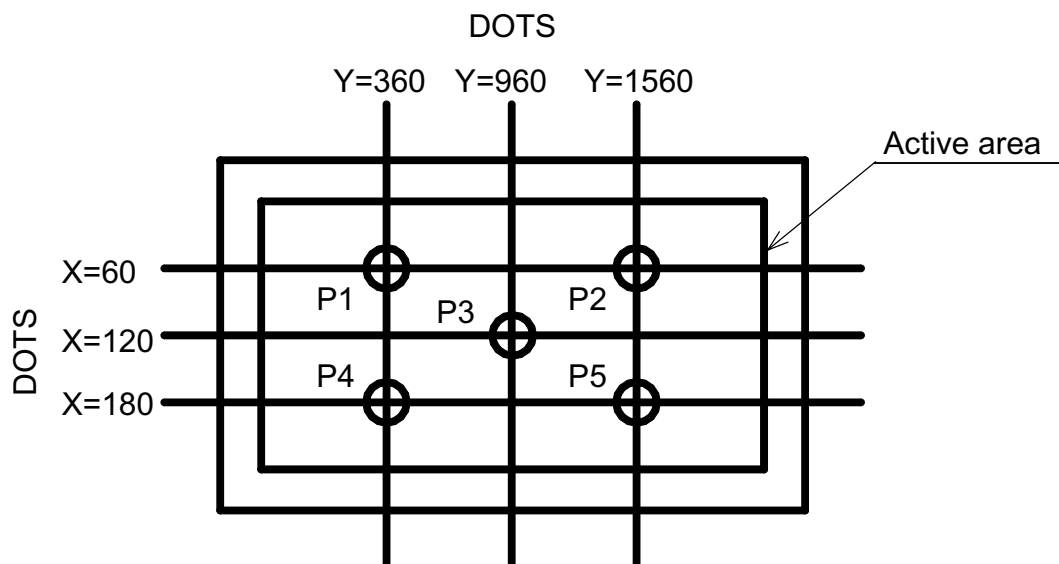

Note 3. The brightness shall be the average of P1~P5 points.

Note 4. Definition of the brightness Uniformity

$$\frac{\text{Max brightness or Min brightness} - \text{Average brightness}}{\text{Average brightness}} \times 100\%$$

6. Interface Timing Chart

6.1 Timing Chart

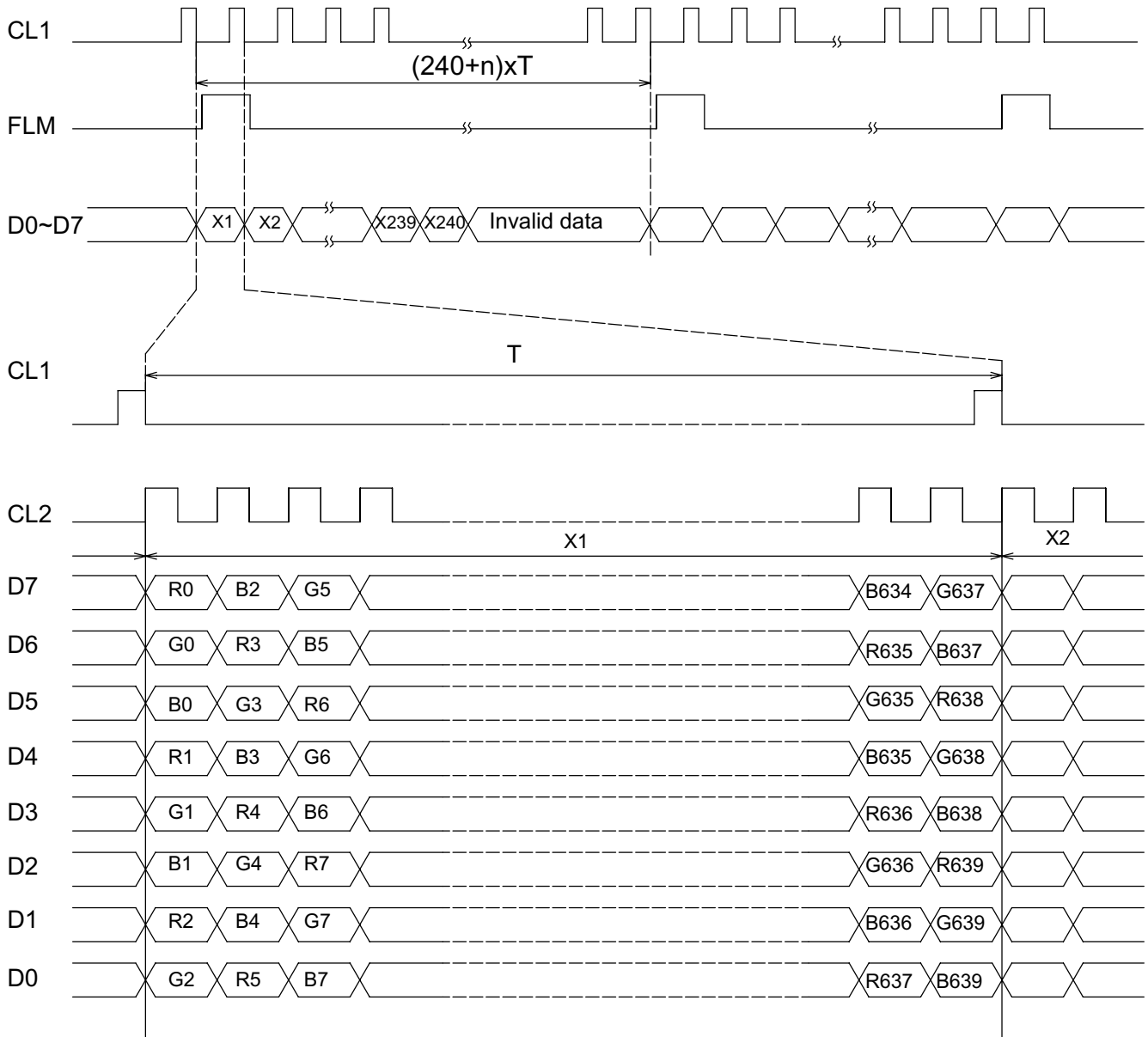

6.2. Electrical Characteristics

($V_{DD}=3.0\sim 4.5V$, $V_{LCD}= +10.0\sim +42.0V$, $T_a= 0\text{ C}\sim 40\text{ C}$)

Item	Symbol	Min.	Typ.	Max.	Unit
Shift clock period	t_{WCK}	66	-	-	ns
Shift clock H pulse wide	t_{WCKH}	23	-	-	ns
Shift clock L pulse wide	t_{WCKL}	23	-	-	ns
Data setup time	t_{DS}	10	-	-	ns
Data hold time	t_{DH}	25	-	-	ns
Latch pulse H pulse wide	t_{WLPH}	30	-	-	ns
Shift clock rise to latch pulse rise time	t_{LD}	10	-	-	ns
Shift clock fall to latch pulse fall time	t_{SL}	30	-	-	ns
Latch pulse rise to shift clock rise time	t_{LS}	30	-	-	ns
Latch pulse fall to shift clock fall time	t_{LH}	30	-	-	ns
Enable setup time	t_{TS}	12	-	-	ns
Input signal rise time	t_R	-	-	50	ns
Input signal fall time	t_F	-	-	50	ns
Output delay	t_D	-	-	44	ns
FLM setup time	t_{FS}	30	-	-	ns
FLM hold time	t_{FH}	50	-	-	ns

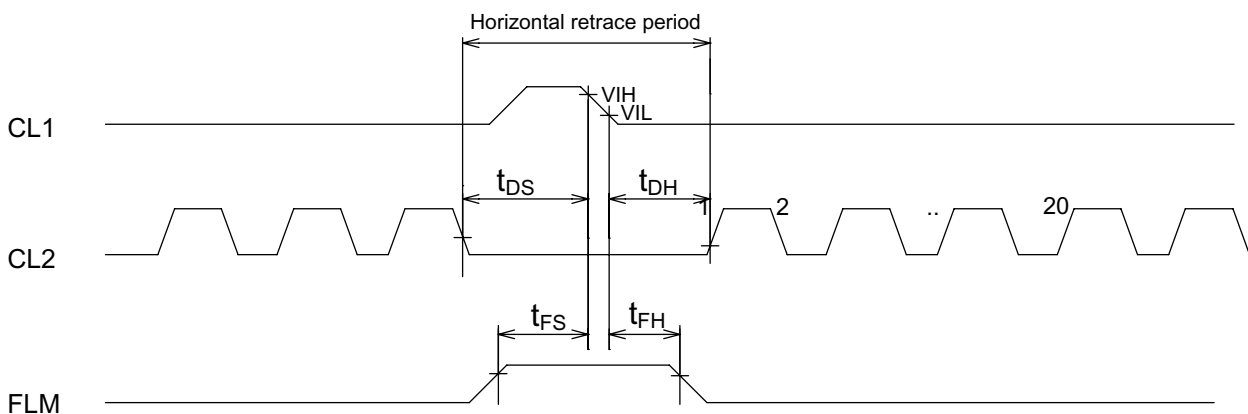
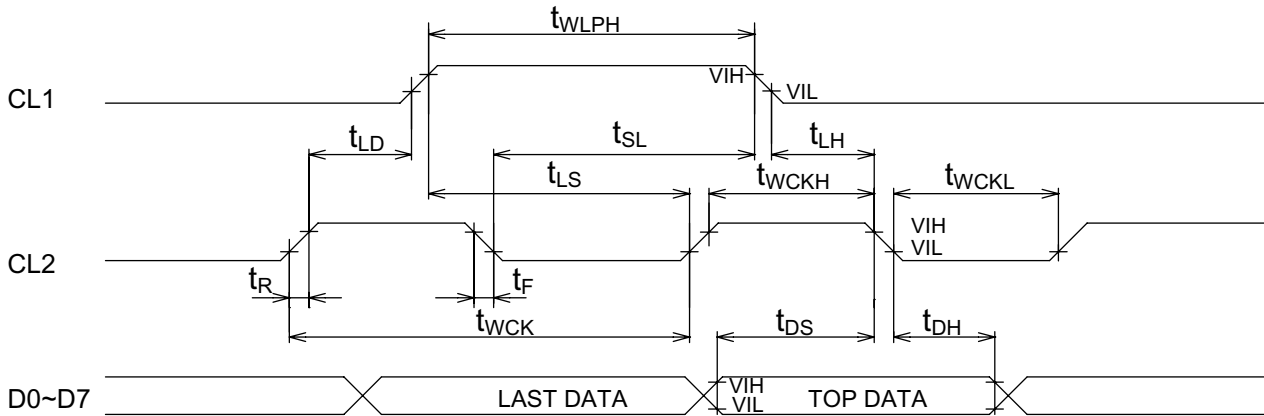

6.3 Power Supply and Signal Sequence

Do not apply DC voltage to the LCD panel because this induces an electrochemical reaction and reduces its lifetime. Please follow the power supply ON/OFF sequence below to prevent DC driving of the LCD or latch-up of the LSIs.

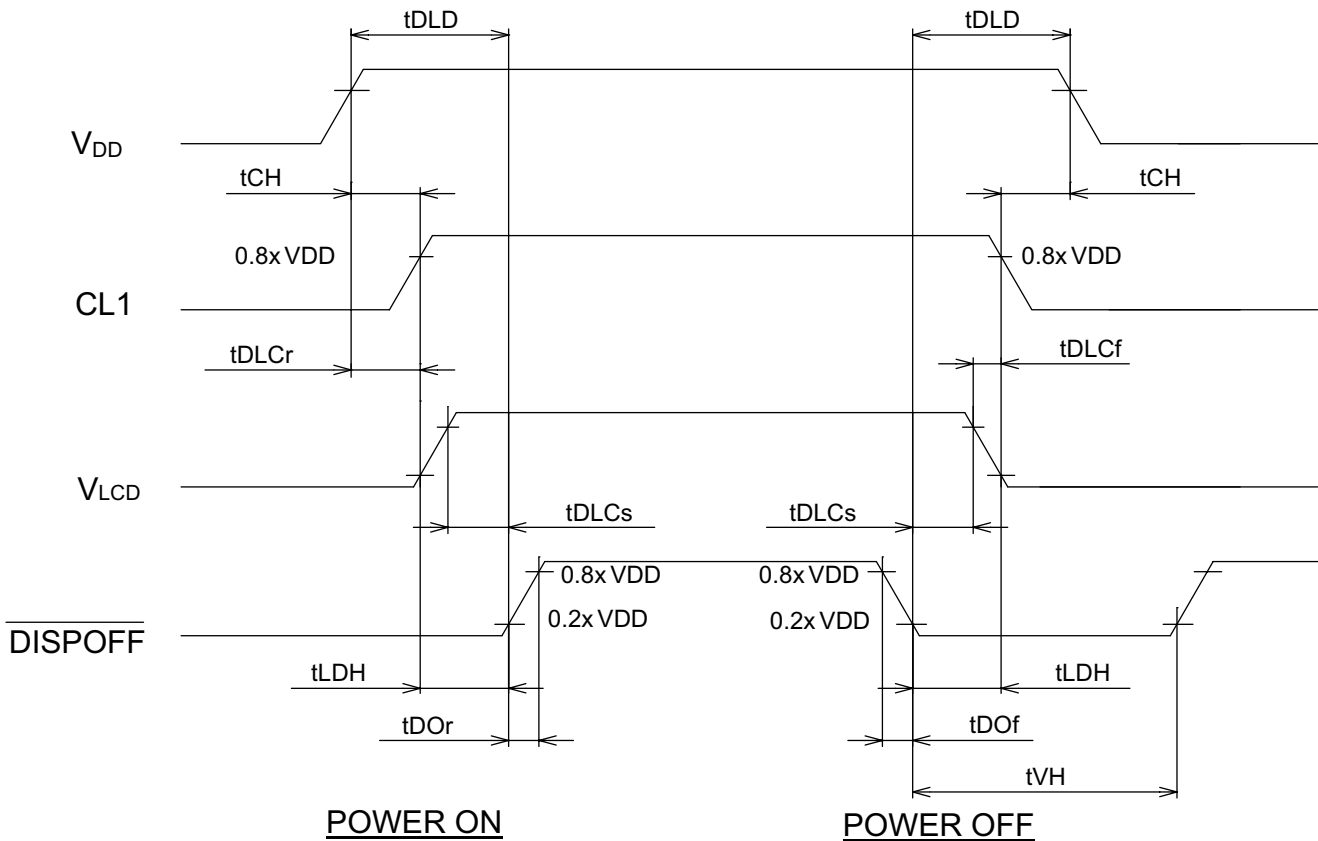

SYMBOL	MIN.	MAX.	UNIT	COMMENT
t_{DLD}	200	-	ms	
t_{CH}	0	-	ms	
t_{LDH}	20	-	ms	
t_{DOOr}	-	100	ns	
t_{DOF}	-	100	ns	
t_{DLCr}	0	-	ms	
t_{DLCf}	0	-	ms	
t_{DLCs}	20	-	ms	
t_{VH}	200	-	ms	

Note 1. Follow the timing sequence as shown above, since an improper sequence may cause permanent damage to the LCD panel.

Note 2. Please use the $\overline{DISPOFF}$ function to turn the display off.

6.4 Input Data Allocation Table

Data Signal	D 7	D 6	D 5	D 4	D 3	D 2	D 1	D 0	D 7	D 6	D 5	D 4		D 4	D 3	D 2	D 1	D 0
Y \ X	1	2	3	4	5	6	7	8	9	10	11	12	-----	1	1	1	1	1
1	R	G	B	R	G	B	R	G	B	R	G	B		G	B	R	G	B
2	R	G	B	R	G	B	R	G	B	R	G	B		G	B	R	G	B
3	R	G	B	R	G	B	R	G	B	R	G	B		G	B	R	G	B
4	R	G	B	R	G	B	R	G	B	R	G	B		G	B	R	G	B
5	R	G	B	R	G	B	R	G	B	R	G	B		G	B	R	G	B
6	R	G	B	R	G	B	R	G	B	R	G	B		G	B	R	G	B
7	R	G	B	R	G	B	R	G	B	R	G	B		G	B	R	G	B
8	R	G	B	R	G	B	R	G	B	R	G	B		G	B	R	G	B
9	R	G	B	R	G	B	R	G	B	R	G	B		G	B	R	G	B
10	R	G	B	R	G	B	R	G	B	R	G	B		G	B	R	G	B
⋮	⋮	⋮	⋮	⋮	⋮	⋮	⋮	⋮	⋮	⋮	⋮	⋮		⋮	⋮	⋮	⋮	⋮
238	R	G	B	R	G	B	R	G	B	R	G	B		G	B	R	G	B
239	R	G	B	R	G	B	R	G	B	R	G	B		G	B	R	G	B
240	R	G	B	R	G	B	R	G	B	R	G	B		G	B	R	G	B

R : RED
 G : GREEN
 B : BLUE

6.5 Power supply for LCM

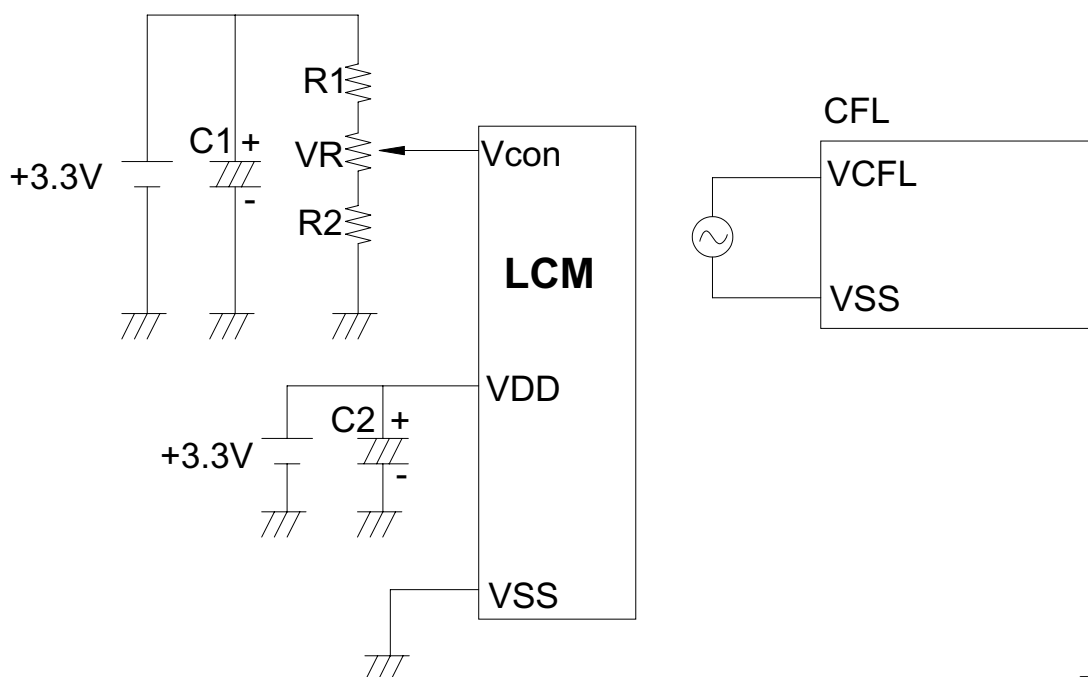

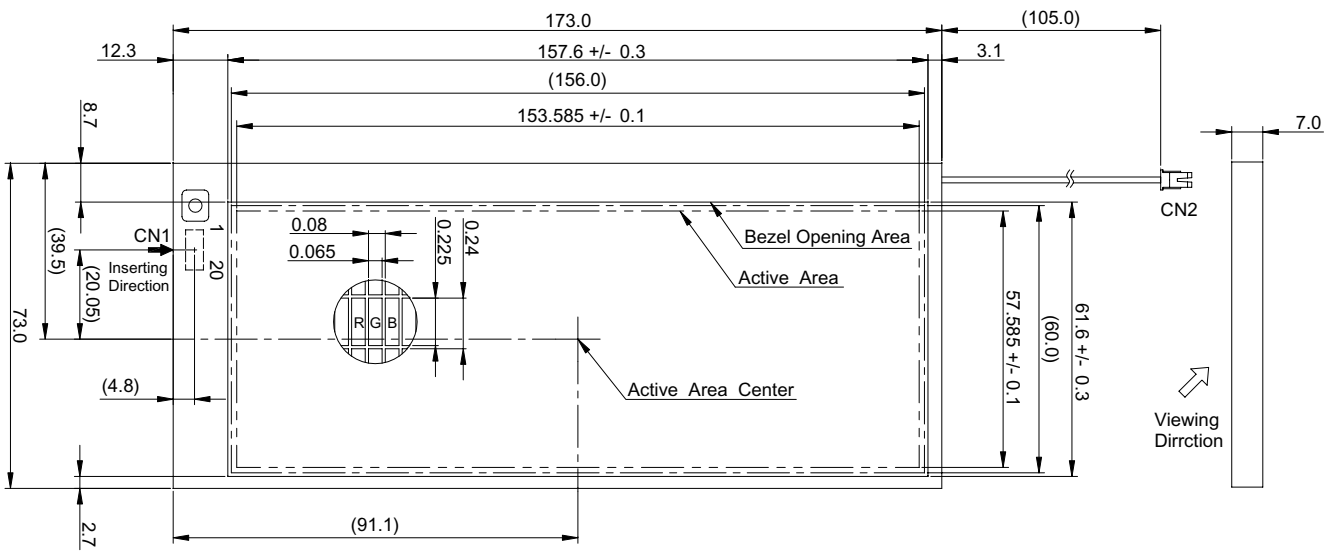

CN1 : 52893-2090(MOLEX)

CN2 : BHSR-02VS-1 (JST)

Note 1 : All dimensional tolerance unless otherwise specified +/-0.5

Note 2 : Scale : NTS , Unit : mm