

1.0Amp Low Dropout Voltage Regulator Adjustable & Fix (0.40Volt Dropout)

B1117

Description

The Bay Linear B1117 is a three terminal positive NPN regulator offered as adjustable or fix voltages of 1.5V, 1.8V, 2.5V, 2.85V, 3.3V, and 5Volts. The output current has a capability up to 1.0Amp,. This device has been optimized for low voltage where transient response and minimum input voltage are critical. The 2.85V version is designed specifically to be used in active terminators for SCSI bus.

Current limit is trimmed to ensure specified output current and controlled short-circuit current. On-Chip thermal limiting provides protection against any combination of overload and ambient temperatures that would create excessive junction temperatures.

The B1117 is offered in a 3-pin SOT-223, and TO-252 (DPAK) packages compatible with other 3 terminal regulators. 5-pin version in TO-263 with lower dropout of 0.4 volt is available.

Features

- Adjustable Output Down to 1.2V
- Output Current of 1.0Amp
- Low Dropout 1.0V for B1117
- Dropout of 0.40 V in for B1117A
- Adjustable & Fix 1.5V, 1.8V, 2.5V, 2.85V, 3.0V, 3.3V, 5.0V
- 0.05% Load Regulation
- Current & Thermal Limiting
- Lower Cost SOT-89 Package
- Available in SOT-223, and TO-252, TO-263 & SO-8
- Similar to industry Standard LT1117

Applications

- Active SCSI terminators
- High efficiency Linear Regulator
- Post regulators fro Switching Supplies
- Battery Charger
- 5V to 3.3V linear Regulators
- Motherboard Clock Supplies

Pin Connection

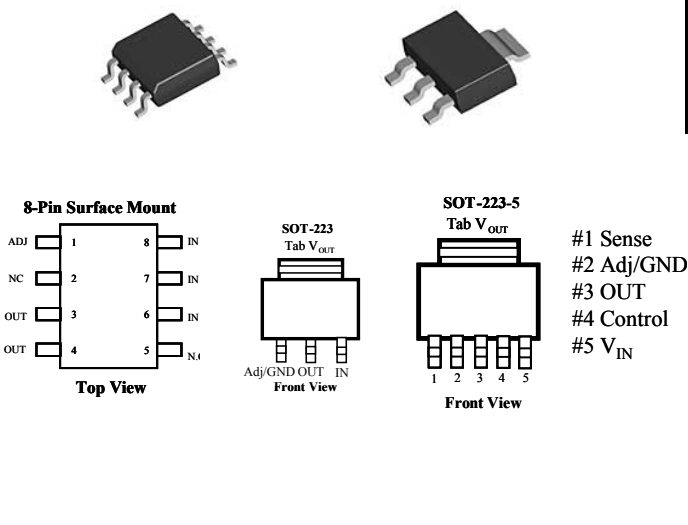

Ordering Information

Devices	Package	Temp.
B1117D-X	TO-252	0 °C to 125 °C
B1117N-X	TO-223	0 °C to 125 °C
B1117T-X	TO-220	0 °C to 125 °C
B1117S-X	TO-263	0 °C to 125 °C
B1117M-X	SO-8	0 °C to 125 °C

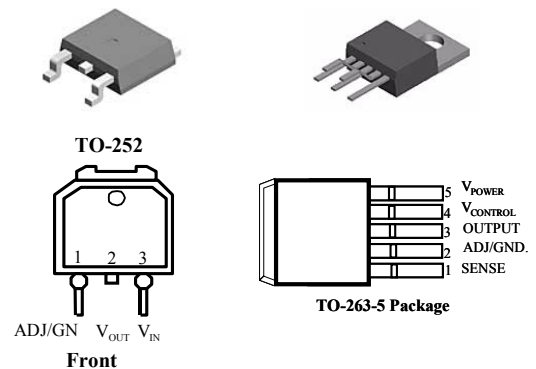

Absolute Maximum Rating

Parameter	Min	Max	Unit
Maximum Input Voltage		7.0	V
Operating Junction Temperature Range	0	125	°C
Storage Temperature Range	-65	150	
Lead Temperature (Soldering 10 Sec.)		300	

Electrical Characteristics

($V_{IN} = 7V$; $T_J = 25^\circ C$ $I_O = 10mA$ to 1.0Amp, unless otherwise specified)

Parameter	Symbol	Conditions	MIN	TYP	MAX	UNIT
Reference Voltage	V_O	1117-adj, $I_{OUT} = 10mA$, $V_{IN} - V_{OUT} = 2V$, $T_J = 25^\circ C$ $1.5V \leq (V_{IN} - V_{OUT}) \leq 5.75V$ $10mA \leq I_{OUT} \leq I_{FULL\ LOAD}$	1.238	1.250	1.262	V
			1.225	1.250	1.275	V
			-2%		+2%	
Line Regulation (1)	$REG_{(line)}$	$(V_{OUT} + 1.5) \leq V_{IN} \leq 7V$, $I_{OUT} = 10mA$		0.005	0.2	%
Load Regulation (1)	$REG_{(LOAD)}$	$(V_{in} - V_{out}) = 2V$ $10mA \leq I_{OUT} \leq I_{FULL\ LOAD}$ $T = 25^\circ C$		0.05	0.5	
Output Voltage	V_O	1117-1.8 $I_{OUT} = 10mA$, $V_{IN} = 3.8V$, $T_J = 25^\circ C$ $0 \leq I_{OUT} \leq 1.0Amp$, $3.2V \leq V_{IN} \leq 7V$	1.782 1.746	1.80 1.80	1.818 1.854	V
		1117-2.5 $I_{OUT} = 10mA$, $V_{IN} = 4.5V$, $T_J = 25^\circ C$ $0 \leq I_{OUT} \leq 1.0Amp$, $4.0V \leq V_{IN} \leq 7V$	2.475 2.450	2.50 2.50	2.525 2.550	V
		1117-2.85 $I_{OUT} = 10mA$, $V_{IN} = 4.85V$, $T_J = 25^\circ C$ $0 \leq I_{OUT} \leq 1.0Amp$, $4.35V \leq V_{IN} \leq 7V$	2.820 2.790	2.85 2.85	2.880 2.910	V
		1117-3.3 $I_{OUT} = 10mA$, $V_{IN} = 5.0V$, $T_J = 25^\circ C$ $0 \leq I_{OUT} \leq 1.0Amp$, $4.8V \leq V_{IN} \leq 7V$	3.267 3.235	3.30 3.30	3.333 3.365	V
		1117-5.0 $I_{OUT} = 10mA$, $V_{IN} = 6.0V$, $T_J = 25^\circ C$ $0 \leq I_{OUT} \leq 1.0Amp$, $6.5V \leq V_{IN} \leq 7V$	4.950 4.900	5.00 5.00	5.050 5.100	V
Dropout Voltage	V_D	Control Input $V_{POWER} = V_{OUT} + 0.8$, $I_{LOAD} = 10mA$		0.80	1.00	V
		Power Input $V_{CONTROL} = V_{OUT} + 2.5V$, $I_{LOAD} = 1.0Amp$,		0.80	1.10	V
Dropout Voltage	V_D	Power Input $V_{CONTROL} = V_{OUT} + 2.5V$, $I_{LOAD} = 1.0Amp$,		0.35	0.40	V
Current Limit	I_S	$(V_{in} - V_{out}) = 2V$	1.0	1.1		A
Minimum Load Current	$I_{MIN\ LOAD}$	$1.5V \leq (V_{IN} - V_{OUT}) \leq 5.75V$	10			mA
Temperature Regulation	T_A	$T = 25^\circ C$, 30ms pulse		0.004	0.02	%/W
Long Term Stability	-	$T = 25^\circ C$, 1000Hrs		0.03	1.0	%
Temperature Stability	T_S			0.5		%
Adjust pin Current	-	$T = 25^\circ C$		35	120	μA
Ripple Rejection	R_A	$F = 120Hz$, $C_{ADJ} = 22\mu F$, $C_{OUT} = 22\mu F$ Tantalum $I_{OUT} = I_{FULL\ LOAD}$, $(V_{in} - V_{out}) = 3V$ (Note 5)	60	75		dB
Thermal Shutdown				155		°C
Thermal Shutdown Hysteresis				10		°C
Thermal Resistance Junction to case	-	SOT-223 DD Package		15	15	°C/W
				3.0	3.0	

Note: Output Switch tests are performed under pulsed conditions to minimize power dissipation

TYPICAL CHARACTERISTICS

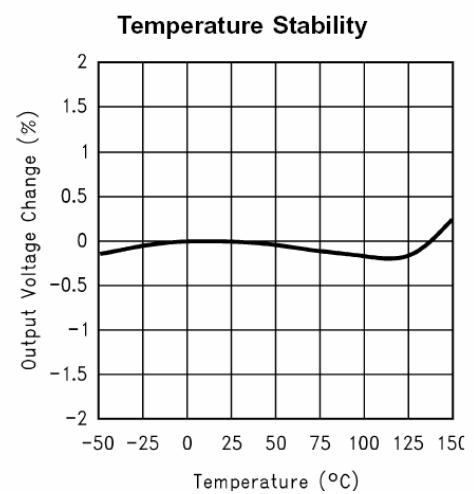
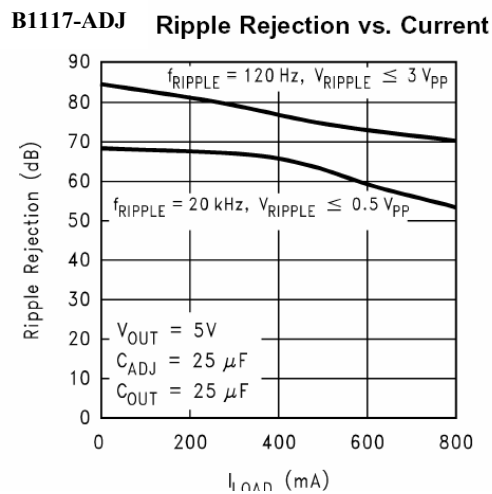
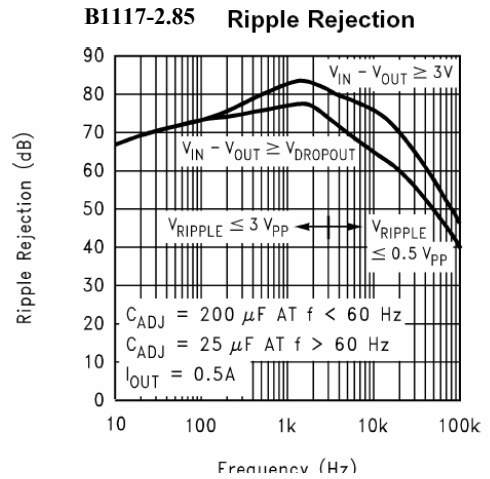
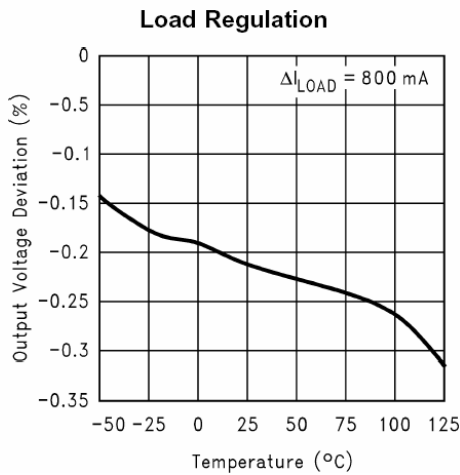
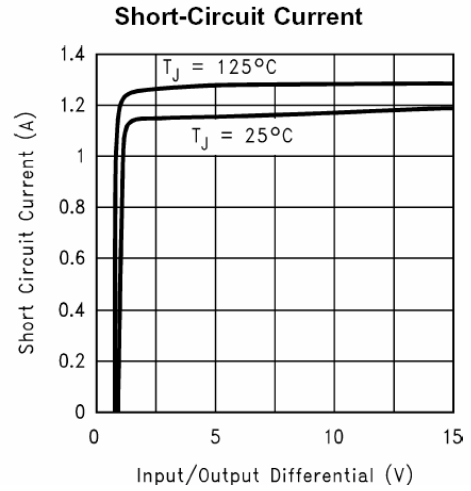
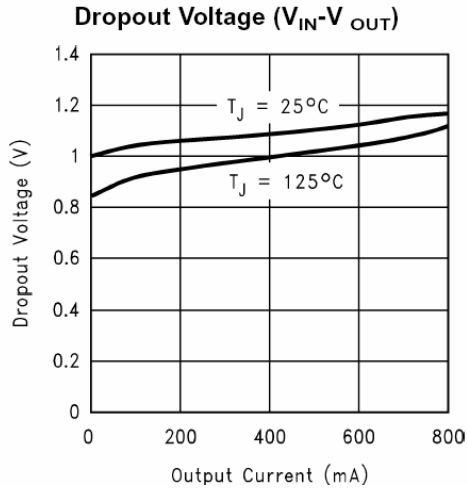

TYPICAL CHARACTERISTICS (Continued)

Dropout Voltage ($V_{IN}-V_{OUT}$)

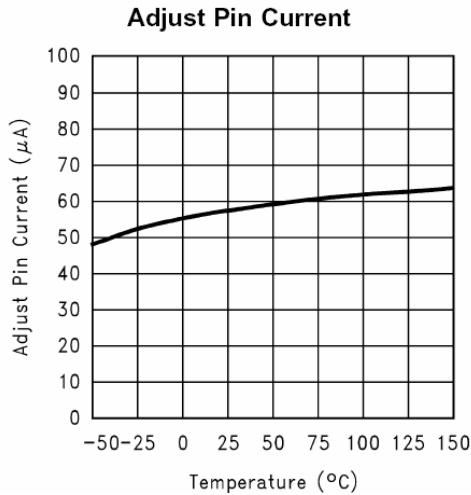

Short-Circuit Current

B1117-2.85 Load Transient Response

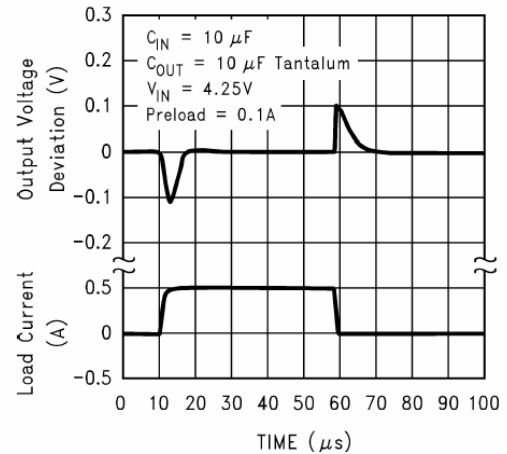

B1117-5.0 Load Transient Response

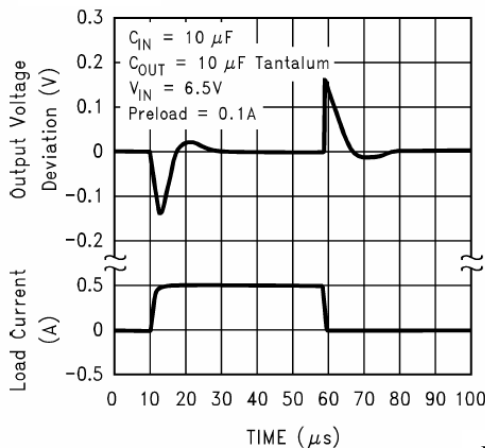

B1117-2.85 Line Transient Response

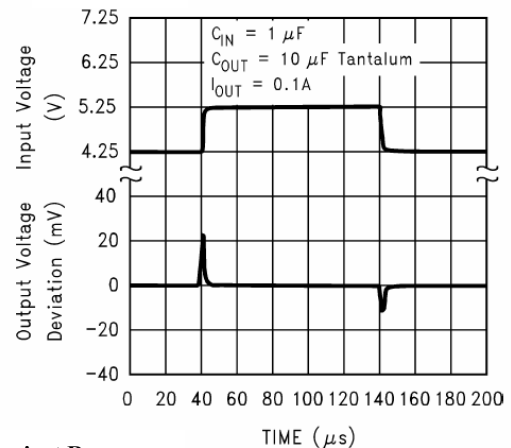

B1117-5.0 Line Transient Response

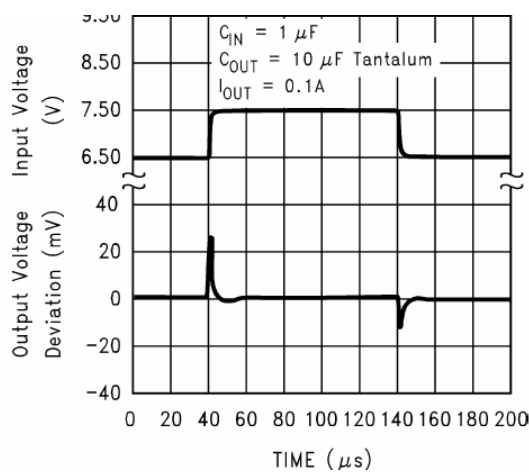

APPLICATION NOTES EXTERNAL CAPACITOR

To ensure the stability of the B1117 an output capacitor of at least 10µF (tantalum) or 50µF (aluminum) is required. The value may change based on the application requirements on the output load or temperature range. The capacitor equivalent series resistance (ESR) will effect the B1117 stability. The value of ESR can vary from the type of capacitor used in the applications. The recommended value for ESR is 0.5Ω. The output capacitance could increase in size to above the minimum value. The larger value of output capacitance as high as 100µF can improve the load transient response.

SOLDERING METHODS

The B1117 SOT-223 package is designed to be compatible with infrared reflow or vapor-phase reflow soldering techniques. During soldering the non-active or mildly active fluxes may be used. The B1117 die is attached to the heat sink lead which exits opposite the input, output, and ground pins.

Hand soldering and wave soldering should be avoided since these methods can cause damage to the device with excessive thermal gradients on the package. The SOT-223 recommended soldering method are as follows: vapor phase reflow and infrared reflow with the component preheated to within 65°C of the soldering temperature range.

THERMAL CHARACTERISTICS

The thermal resistance of B1117 is 15°C/W from junction to tab and 31 °C/W from tab to ambient for a total of 46 °C/W from junction to ambient. The B1117 features the internal thermal limiting to protect the device during overload conditions. Special care needs to be taken during continues load conditions the maximum junction temperature does not exceed 125 °C.

Taking the FR-4 printed circuit board and 1/16 thick with 1 ounce copper foil as an experiment (fig.1 & fig.2), the PCB material is effective at transmitting heat with the tab attached to the pad area and a ground plane layer on the backside of the substrate. Refer to table 1 for the results of the experiment.

The thermal interaction from other components in the application can effect the thermal resistance of the B1117. The actual thermal resistance can be determined with experimentation. B1117 power dissipation is calculated as follows:

$$P_D = (V_{IN} - V_{OUT})(I_{OUT})$$

Maximum Junction Temperature range:

$$T_J = T_{ambient} (max) + P_D * \text{thermal resistance (Junction-to-ambient)}$$

Maximum Junction temperature must not exceed the 125°C.

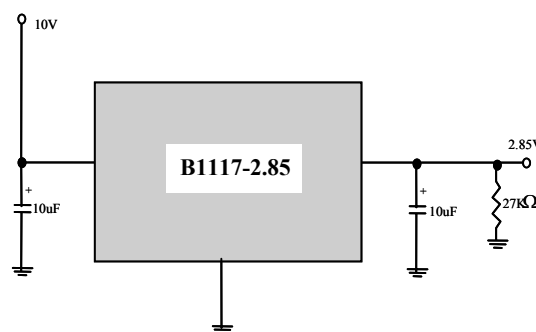

$$P_o = (10V - 2.85)(105mA) = (7.15)(105mA) = 750mW$$

Fig. 1. Circuit Layout, Thermal Experiments.

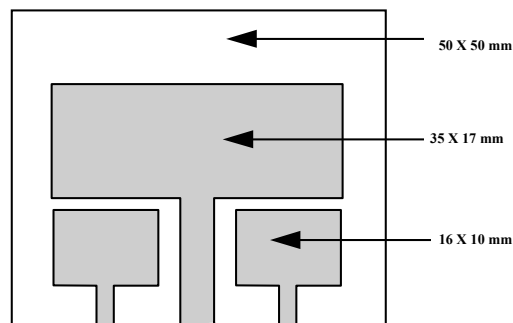
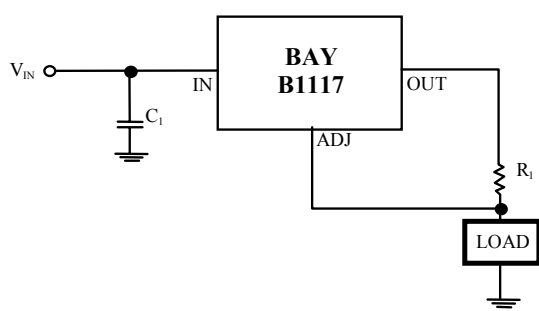

Fig. 2. Substrate Layout for SOT-223

B1117

TOTAL PC BOARD AREA	TOPSIDE COPPER AREA	BACKSIDE COPPER AREA	THERMAL RESISTANCE JUNCTION TO AMBIENT
2500mm	2500mm	2500mm	46°C/W°
2500mm	1250mm	2500mm	47°C/W°
2500mm	950mm	2500mm	49°C/W°
2500mm	2500mm	0	51°C/W°
2500mm	1800mm	0	53°C/W°
1600mm	600mm	1600mm	55°C/W°
2500mm	1250mm	0	58°C/W°
2500mm	915mm	0	59°C/W°
1600mm	600mm	0	67°C/W°
900mm	240mm	900mm	72°C/W°
900mm	240mm	0	85°C/W°



1.0Amp Current output

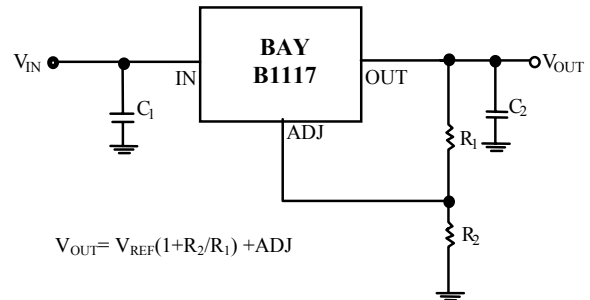

$$V_{OUT} = V_{REF}(1 + R_2/R_1) + ADJ$$

Typical Adjustable Regulator

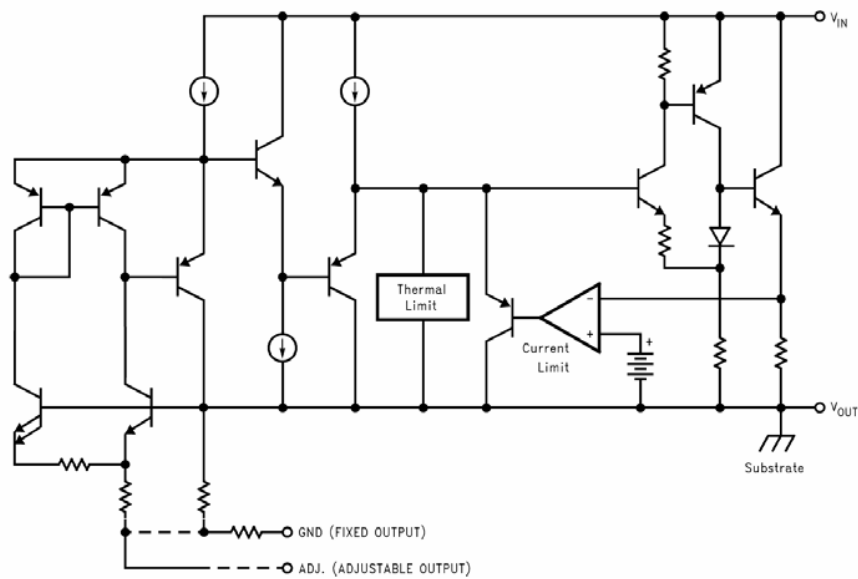

SOT223 Package

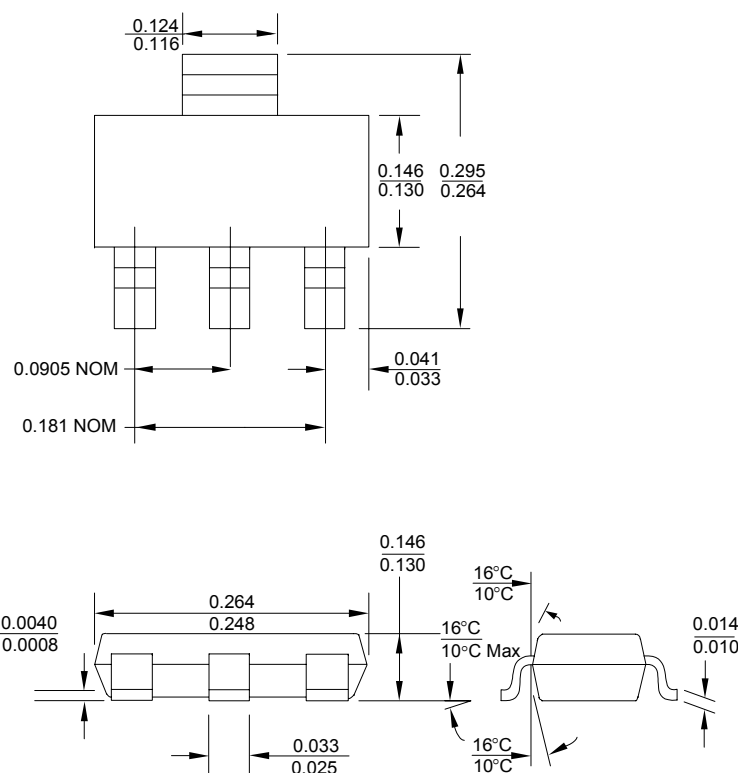

Advance Information- These data sheets contain descriptions of products that are in development. The specifications are based on the engineering calculations, computer simulations and/ or initial prototype evaluation.

Preliminary Information- These data sheets contain minimum and maximum specifications that are based on the initial device characterizations. These limits are subject to change upon the completion of the full characterization over the specified temperature and supply voltage ranges.

The application circuit examples are only to explain the representative applications of the devices and are not intended to guarantee any circuit design or permit any industrial property right to other rights to execute. Bay Linear takes no responsibility for any problems related to any industrial property right resulting from the use of the contents shown in the data book. Typical parameters can and do vary in different applications. Customer's technical experts must validate all operating parameters including "Typical" for each customer application.

LIFE SUPPORT AND NUCLEAR POLICY

Bay Linear products are not authorized for and should not be used within life support systems which are intended for surgical implants into the body to support or sustain life, in aircraft, space equipment, submarine, or nuclear facility applications without the specific written consent of Bay Linear President.