



Bay Linear

Inspire the Linear Power

5.0A Low Dropout Voltage Regulator

Adjustable & Fix Output

B1585

Description

The Bay Linear B1585 is Monolithic low power 5.0A Adjustable and fixed NPN voltage regulator that are easy to use with minimum external components. It is suitable for applications requiring a well-regulated positive output voltage with low input-output differential voltage requirements and output voltage 1.5V, 2.5V, 3.0V, 3.3V, or 5V.

The B1585 Outstanding features include full power usage up to 5.0Amp of load current internal current limiting and thermal shutdown. Other fixed versions are also available consult with factory.

The B1585 is offered in 3-pin TO-220, LPDD & TO-263 packages compatible with other 3 terminal regulators. For 7A Low dropout Regulator refer to the B1584 data sheet.

Features

- Adjustable Output Down to 1.2V
- Fixed Output Voltages 2.5V, 3.0V 3.3V, and 5.0V
- Output Current of 5.0A
- Low Dropout Voltage 1.1V Typ.
- Current & Thermal Limiting
- Standard 3-Terminal Low Cost TO-220, LPDD, & D² Packages
- Similar to industry Standard LT1084/LT1585

Applications

- 3.3V to 2.5V for Pentium Processor
- SMPS Post Regulator
- High Efficiency “Green” Computer Systems
- High Efficiency Linear Power Supplies
- 5V to 3.XXV fro Pentium Processor
- Battery Charger

Pin Connection

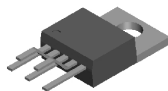

TO-263-3 (S)

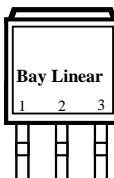

Top View

Ordering Information

Devices	Package	Temp.
B1585T	TO-220	0 °C to 70 °C
B1585S	TO-263	0 °C to 70 °C
B1585j	LPDD	0 °C to 70 °C



PLDD (J)

Absolute Maximum Rating

Parameter	Symbol	Value	Unit
Maximum Input Voltage	V_{IN}	7	V
Power Dissipation	P_O	Internally Limited	W
Thermal Resistance Junction to Case	θ_{JC}	3	°C/W
Thermal Resistance Junction to Ambient	θ_{JA}	50	
Operating Junction Temperature Range Control Section Power Transistor	T_J	0 to 125 0 to 150	°C
Storage Temperature Range	T_{STG}	-65 to 150	
Lead Temperature (Soldering 10 Sec.)	T_{LEAD}	260	

Electrical Characteristics

($V_{IN} = 4.75V$ to $5.25V$; $I_O = 10mA$ to $5.0Amp$, unless otherwise specified)

Parameter	Symbol	Conditions	MIN	TYP	MAX	UNIT	
Output Voltage	V_O	0< I_{OUT} <5A, 3.3V< V_{IN} <7V, T= 25 °C	1.485	1.5	1.515	V	
		0< I_{OUT} <5A, 3.3V< V_{IN} <7V, Over Temp.	1.475		1.525		
		0< I_{OUT} <5A, 4.0V< V_{IN} <7V, T= 25 °C	2.475	2.5	2.525		
		0< I_{OUT} <5A, 4.0V< V_{IN} <7V, Over Temp.	2.460		2.540		
		0< I_{OUT} <5A, 4.5V< V_{IN} <7V, T= 25 °C	2.970	3.0	3.030		
		0< I_{OUT} <5A, 4.5V< V_{IN} <7V, Over Temp.	2.950		3.050		
		0< I_{OUT} <5A, 4.8V< V_{IN} <7V, T= 25 °C	3.267	3.3	3.333		
		0< I_{OUT} <5A, 4.8V< V_{IN} <7V, Over Temp.	3.247		3.353		
0< I_{OUT} <5A, 6.5V< V_{IN} <7V, T= 25 °C	4.950	5.0	5.050				
0< I_{OUT} <5A, 6.5V< V_{IN} <7V, Over Temp.	4.920		5.080				
Reference Voltage	V_{ref}	V_{IN} <7V, 1.5V< V_{IN} <5.75, 10mA< I_{out} <5Amp	1.238 1.230	1.250	1.262 1.270	V	
Line Regulation (1)	REG _(line)	$I_O = 10mA$, $V_{IN} = 5V$, T= 25 °C		0.04	0.2	%	
Load Regulation (1)	REG _(LOAD)	$I_O = 10mA$, $V_{IN} = 5V$, T= 25 °C		0.08	0.40		
Dropout Voltage	V_D	T= 25 °C Over Temperature		1.0		V	
				1.1	1.3		
Minimum load Current	I_{min}			5.0	10	mA	
Current Limit	I_S	$(V_{in}-V_{out})=3V$	5.5	6.8		A	
Ground Pin Current	I_Q	$V_{IN} = 5V$		6	10	mA	
Temperature Stability	T_S	$I_O = 10mA$, $V_{IN} = 5V$		0.5		%	
Thermal Regulation		T= 25 °C, 30ms pulse		0.003		%/W	
Ripple Rejection	R_A	T= 25 °C, $V_{IN} = 5V$	60	80		dB	
Thermal Resistance	-	TO-220	Junction to Tab		3.0	3.0	°C/W
			Junction to Ambient		60	60	
		DD Package	Junction to Tab		3.0	3.0	
			Junction to Ambient		60	60	

Note: Output Switch tests are performed under pulsed conditions to minimize power dissipation

APPLICATION HINTS

The Bay Linear B1585 incorporates protection against over-current faults, reversed load insertion, over temperature operation, and positive and negative transient voltage. However, the use of an output capacitor is required in order to insure the stability and the performances.

Stability

The output capacitor is part of the regulator's frequency compensation system. Either a 220 μ F aluminum electrolytic capacitor or a 47 μ F solid tantalum capacitor between the output terminal and ground guarantees stable operation for all operating conditions.

However, in order to minimize overshoot and undershoot, and therefore optimize the design, please refer to the section 'Ripple Rejection'.

Ripple Rejection

Ripple rejection can be improved by adding a capacitor between the ADJ pin and ground. When ADJ pin bypassing is used, the value of the output capacitor required increases to its maximum (220 μ F for an aluminum electrolytic capacitor, or 47 μ F for a solid tantalum capacitor). If the ADJ pin is not bypass, the value of the output capacitor can be lowered to 100 μ F for an electrolytic aluminum capacitor or 15 μ F for a solid tantalum capacitor. However the value of the ADJ-bypass capacitor should be chosen with respect to the following equation:

$$C = 1 / (6.28 * F_R * R_1)$$

Where C = value of the capacitor in Farads (select an equal or larger standard value),

F_R = ripple frequency in Hz,

R₁ = value of resistor R₁ in Ohms.

If an ADJ-bypass capacitor is use, the amplitude of the output ripple will be independent of the output voltage. If an ADJ-bypass capacitor is not used, the output ripple will be proportional to the ratio of the output voltage to the reference voltage:

$$M = V_{OUT} / V_{REF}$$

Where M = multiplier for the ripple seen when the ADJ pin is optimally bypassed.

V_{REF} = Reference Voltage

Reducing parasitic resistance and inductance

One solution to minimize parasitic resistance and inductance is to connect in parallel capacitors. This arrangement will improve the transient response of the power supply if your system requires rapidly changing current load condition.

Thermal Consideration

Although the B1585 offers some limiting circuitry for overload conditions, it is necessary not to exceed the maximum junction temperature, and therefore to be careful about thermal resistance. The heat flow will follow the lowest resistance path, which is the Junction-to-case thermal resistance. In order to insure the best thermal flow of the component, a proper mounting is required. Note that the case of the device is electrically connected to the output. In case the case has to be electrically isolated, a thermally conductive spacer can be used. However do not forget to consider its contribution to thermal resistance.

Assuming:

$$V_{IN} = 7V, V_{OUT} = 5V, I_{OUT} = 5A, T_A = 90^{\circ}C, \theta_{CASE} = 1^{\circ}C/W \text{ (no external heat sink, no wind)}$$

Power dissipation under these conditions

$$P_D = (V_{IN} - V_{OUT}) * I_{OUT} = 15W$$

Junction Temperature

$$T_J = T_A + P_D * (\theta_{CASE} + \theta_{JC})$$

For the Control Section

$$T_J = 90^{\circ}C + 15W * (1^{\circ}C/W + 0.6^{\circ}C/W) = 114^{\circ}C$$

114 $^{\circ}$ C < T_{JUNCTION MAX} for the control section.

For the Power Section

$$T_J = 90^{\circ}C + 15W * (1^{\circ}C/W + 1.6^{\circ}C/W) = 129^{\circ}C$$

129 $^{\circ}$ C < T_{JUNCTION MAX} for the power transistor.

In both case reliable operation is insured by adequate junction temperature.

Basic Adjustable Regulator

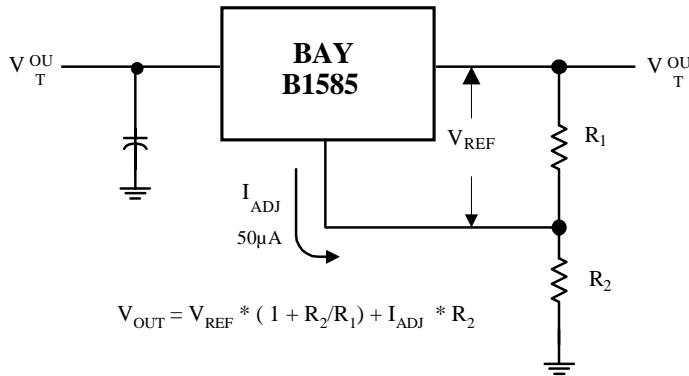

Fig.2 Basic Adjustable Regulator

Output Voltage

Consider Figure 2. The resistance R_1 generates a constant current flow, normally the specified load current of 10mA. This current will go through the resistance R_2 to set the overall output voltage. The current I_{ADJ} is very small and constant. Therefore its contribution to the overall output voltage is very small and can generally be ignored

Load Regulation

Parasitic line resistance can degrade load regulation. In order not to affect the behavior of the regulator, it is best to connect directly the R_1 resistance from the resistor divider to the case, and not to the load. For the same reason, it is best to connect the resistor R_2 to the Negative side of the load.

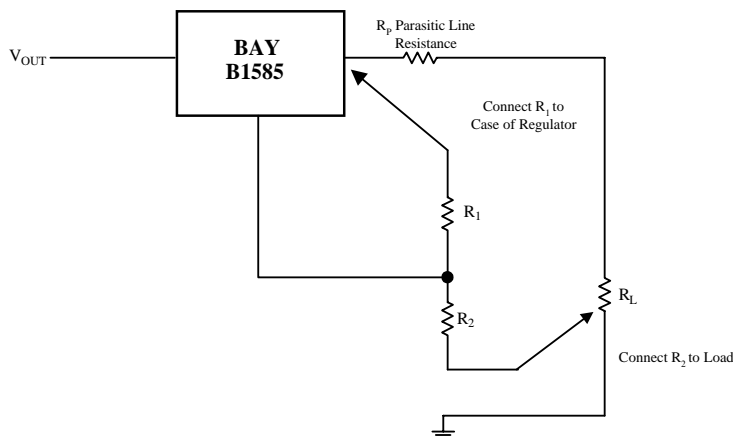

Fig.3 Basic Adjustable Regulator

Application Diagrams

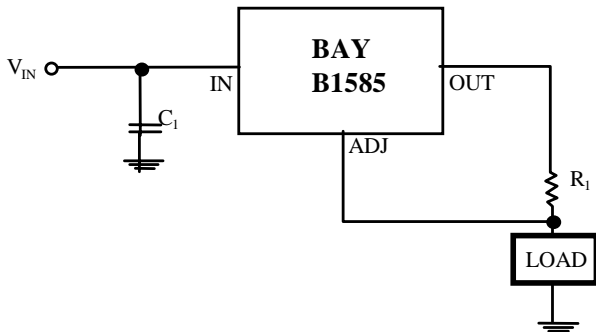
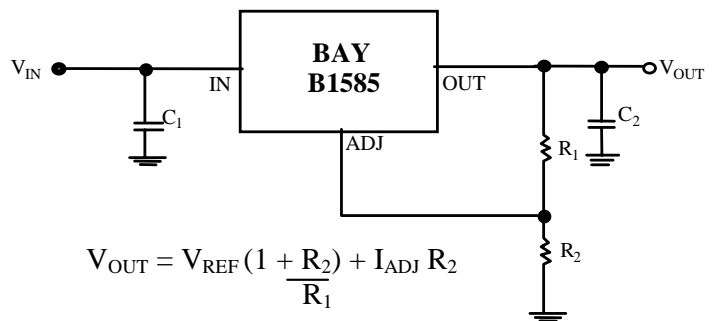

Fig.4 5A Current Output Regulator



$$V_{OUT} = V_{REF} \left(1 + \frac{R_2}{R_1}\right) + I_{ADJ} R_2$$

Fig 5. Typical Adjustable Regulator

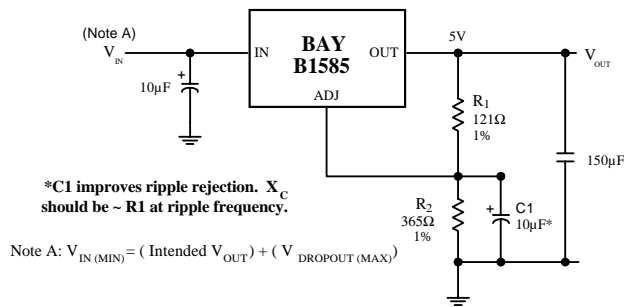

Fig. 6 Improving Ripple Rejection

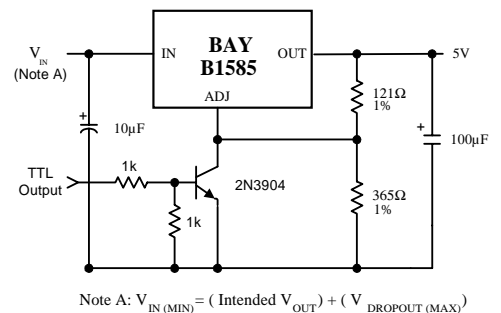
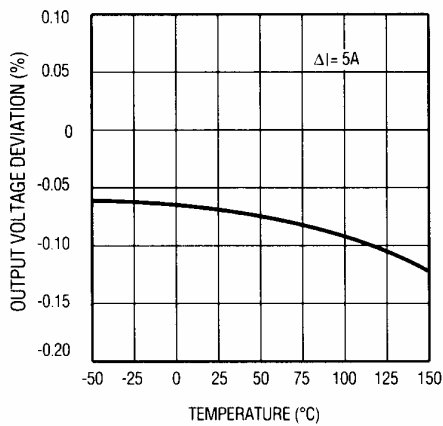

Fig.7 5V Regulator with Shutdown

Typical Characteristics

TYPICAL PERFORMANCE CHARACTERISTICS

LOAD REGULATION



SHORT CIRCUIT CURRENT

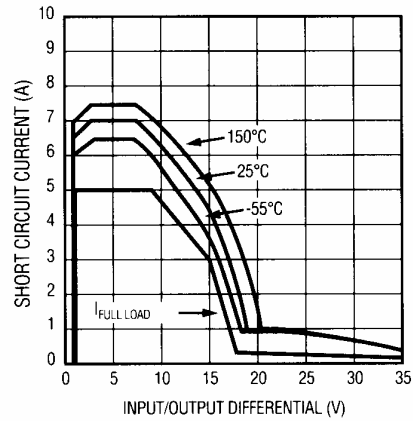

ADJUSTMENT PIN CURRENT

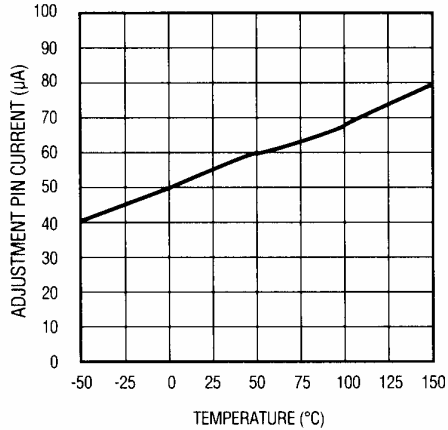

DROPOUT VOLTAGE

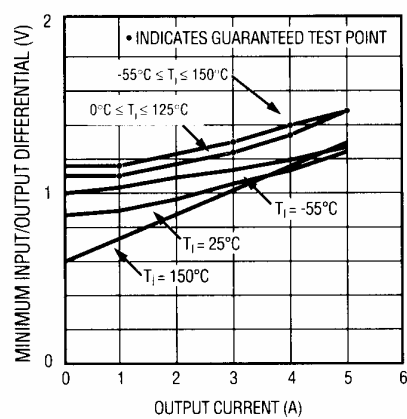

TEMPERATURE STABILITY

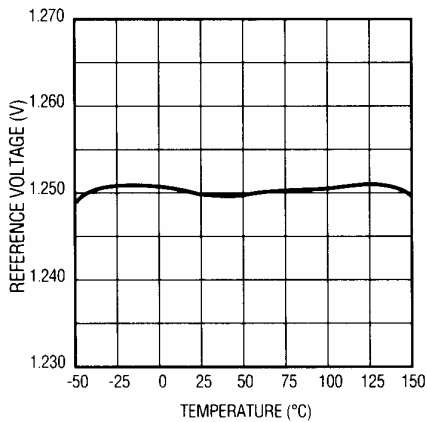

MINIMUM OPERATING CURRENT

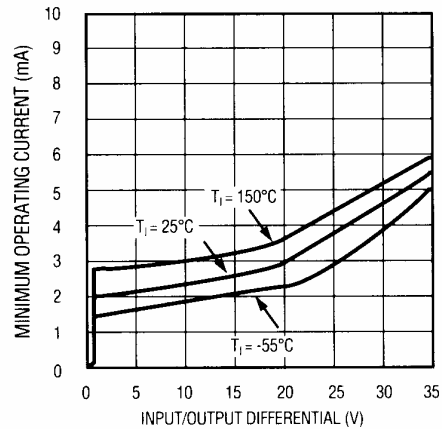

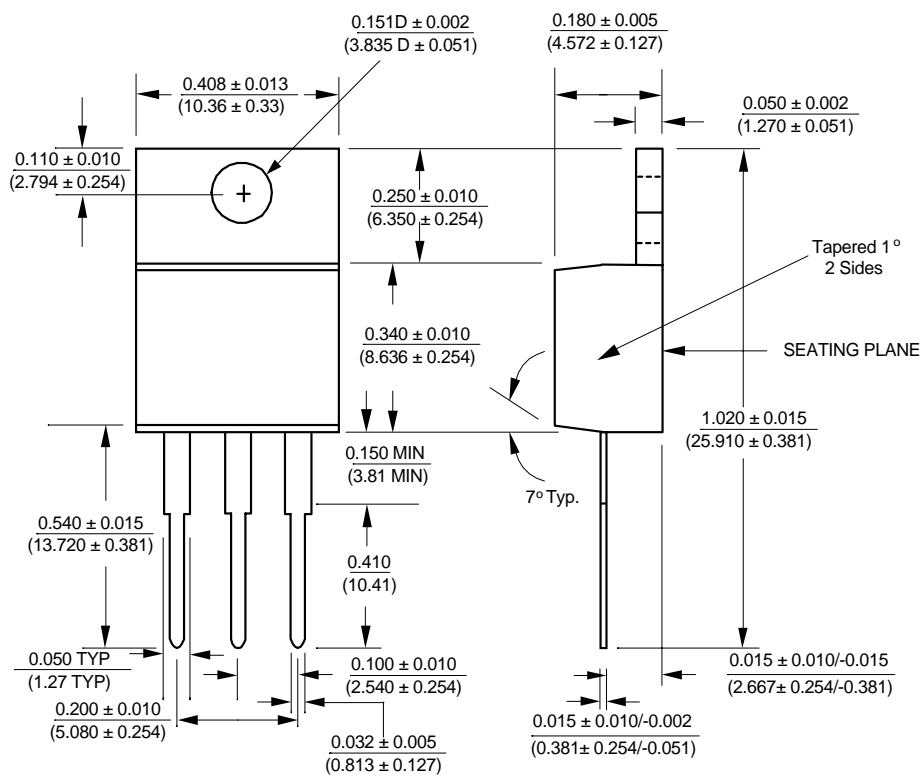
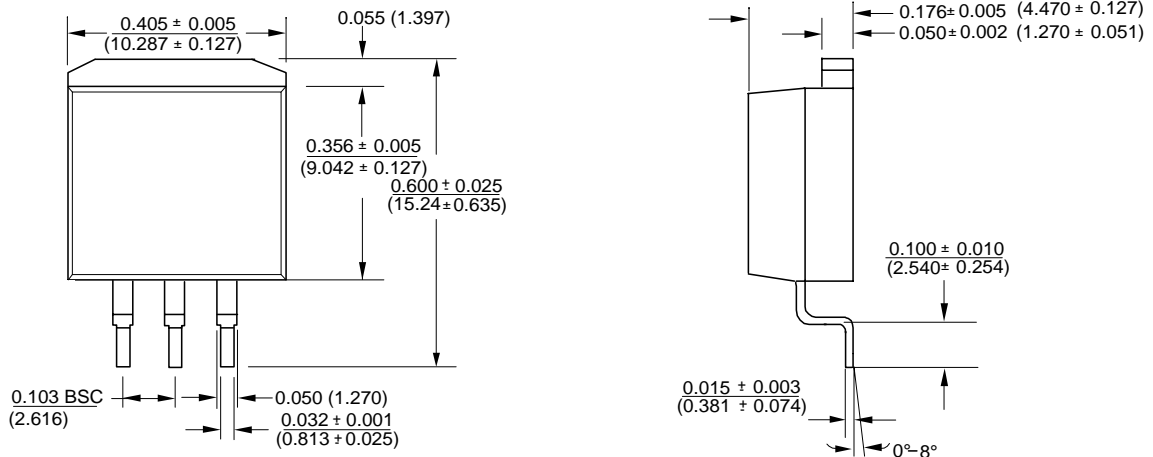

Advance Information- These data sheets contain descriptions of products that are in development. The specifications are based on the engineering calculations, computer simulations and/ or initial prototype evaluation.

Preliminary Information- These data sheets contain minimum and maximum specifications that are based on the initial device characterizations. These limits are subject to change upon the completion of the full characterization over the specified temperature and supply voltage ranges.

The application circuit examples are only to explain the representative applications of the devices and are not intended to guarantee any circuit design or permit any industrial property right to other rights to execute. Bay Linear takes no responsibility for any problems related to any industrial property right resulting from the use of the contents shown in the data book. Typical parameters can and do vary in different applications. Customer's technical experts must validate all operating parameters including " Typical" for each customer application.

LIFE SUPPORT AND NUCLEAR POLICY

Bay Linear products are not authorized for and should not be used within life support systems which are intended for surgical implants into the body to support or sustain life, in aircraft, space equipment, submarine, or nuclear facility applications without the specific written consent of Bay Linear President.
