

**1.25A High Current Low Dropout
Voltage Regulator Adjustable**

LM2940/2941

Description

The Bay Linear LM2940 & LM2941 is a 1.25A high accuracy, low dropout voltage regulator with only 40mV at light loads and 350mV(Typ.)@ 1.0A) and low quiescent current of 240µA typical.

The LM2940/41 is designed for low voltage a application that requires lower dropout voltage and faster transient response. This device is an excellent choice for use in powering low voltage applications where require a lower dropout, faster transient response to regulate from +2.5V to 3.8V supplies and as a post regulator for switching supplies applications.

The LM2940/41 offers full protection against over-current faults, reversed input polarity, reversed load insertion, and positive and negative transient voltage. On-Chip trimming adjusts the reference voltage to 1%. The LM2940-xx devices are in 3 pin fixed voltage regulators. The LM2941 include an Enable pin in the 5 pin packages.

The LM2940/41 are offered in a 3 & 5-pin SOT-223, TO-220 & TO-263 package compatible with other 3 terminal regulators. The LM2940/41 is also offer in a new LPDD (Low Profile TO-263) package from 4.47 mm (DD) tickness down to only 1.27 mm

Features

- High output accuracy of 1%
- Output Adjustable from 1.24V to 26V
- Output Current of 1.25A
- Low Dropout Voltage
- Low quiescent current
- Extremely Tight Load & Line Regulation
- Reverse-battery and “Load Dump” Protection
- Zero Current Shutdown Mode (5-pin version)
- Offer in TO-263, TO-220, SOT-223, & New Slim LPDD
- Similar to industry Standard MIC2940LM2941

Applications

- Powering VGA & Sound Card
- LCD Monitor
- Battery Powered Equipments/Laptop & Notebook
- SMPS Post Regulator / DC to DC Modules
- High Efficiency Linear Power Supply
- Adjustable Power Supply
- Bar Code Scanners

Pin Connection

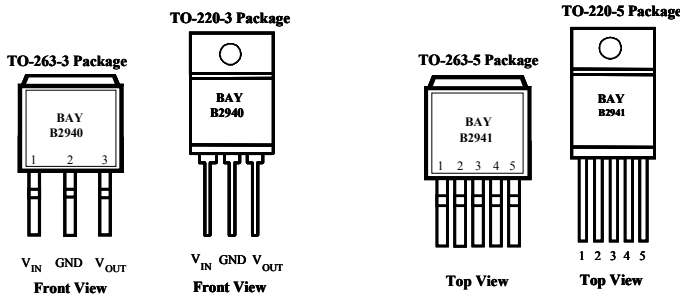

- 1) ADJUST
- 2) ON/OFF
- 3) GND
- 4) INPUT
- 5) OUTPUT

Ordering Information

Devices	Package	Temp.
LM2940T	TO-220-3	-40 °C to 125 °C
LM2941T	TO-220-5	-40 °C to 125 °C
LM2940S	TO-263-3	-40 °C to 125 °C
LM2941S	TO-263-5	-40 °C to 125 °C
LM2940N	SOT-223-3	-40 °C to 125 °C
LM2941N	SOT-223-5	-40 °C to 125 °C
LM2940J	LPDD-3	-40 °C to 125 °C
LM2941J	LPDD-5	-40 °C to 125 °C

ABSOLUTE MAXIMUM RATINGS

Lead Temp. (Soldering, 5 Seconds).....	260°C
Storage Temperature Range.....	-65° to +150°C
Operating Junction Temperature Range	
LM2940/2941 Control Section.....	-45°C +125°C
LM2940/2941 Power Transistor.....	-45°C +150°C

Input Voltage	26V
Maximum Output Current.....	3.5A
Input Supply Voltage (Note1) (Survival)-	-20V to +60V

ELECTRICAL CHARACTERISTICS (NOTE 1) at $I_{OUT} = 5mA$, $V_{IN} = V_{OUT} + 1V$, $I_1 = 1000mA$, $C_L = 10\mu F$, $T_a = 25^\circ C$, unless otherwise specified. The LM2941 is programmed to output 5V and has $V_{SHUTDOWN} \leq 0.6V$

PARAMETER	CONDITIONS	Typ	LM2940		Units
			Min	Max	
2.5V Version					
Output Voltage (Note 2)	$I_{OUT} = 5mA$ $5mA \leq I_{OUT} \leq 1.25A$, $4.75V \leq V_{IN} \leq 26V$	2.5 2.5	2.475 2.450	2.525 2.550	V
3.3V Version2.					
Output Voltage (Note 2)	$I_{OUT} = 5mA$ $5mA \leq I_{OUT} \leq 1.25A$, $4.75V \leq V_{IN} \leq 26V$	3.3 3.3	3.267 3.234	3.330 3.366	V
5.0V Version					
Output Voltage (Note 2)	$I_{OUT} = 5mA$ $5mA \leq I_{OUT} \leq 1.25A$, $5.5V \leq V_{IN} \leq 26V$	5.0 5.0	4.95 4.90	5.05 5.10	V
Output Voltage Accuracy	$5mA \leq I_{OUT} \leq 1.0A$		-1 -2 -2.5	1 2 2.5	%
All Voltage Options					
Line Regulation	$I_O = 5mA$, $(V_{OUT} + 1V) \leq V_{IN} \leq 26V$	0.06		0.5	%
Load Regulation	$V_{IN} = V_{OUT} + 5V$, $5mA \leq I_{OUT} \leq 1A$ (Note 2, 6)	0.2		1.6	%
$\frac{\Delta V^\circ}{\Delta T}$	Output Voltage (Note 6) Temperature Coef.	20		100	ppm/°C
Dropout Voltage	$I_O = 5mA$	80		150	mV
	$I_O = 1000mA$	350		450	
	$I_O = 1.25A$	400		600	
Ground Current	$I_O = 5mA$, $V_{IN} = V_{OUT} + 1V$	240		350	μA mA
	$I_O = 1000mA$, $V_{IN} = V_{OUT} + 1V$	22		35	
	$I_O = 1.25A$	35		70	
I_{GNDDO} Ground Pin Current at Dropout	$V_{IN} = 0.5V$ less than specified V_{OUT} $I_{OUT} = 10mA$	0.9			mA
Current Limit	$V_{OUT} = 0V$ (Note 4)	1.7	1.5		A
Output Noise Voltage (10Hz to 100kHz) $I_L = 100mA$	$C_L = 10\mu F$	400			μV_{RMS}
	$C_L = 33\mu F$	260			
Reference Voltage		1.235	1.223 1.210	1.247 1.260	V V_{max}
	(Note 8)		1.204	1.266	
Adjust Pin Bias Current		40		80 120	nA
Reference Voltage Temperature Coefficient	(Note 7)	20			ppm/°C
Adjust Pin Bias Current Temperature Coefficient		0.1			nA/°C

ENABLE Input LM2941					
Input Logic Voltage Low (OFF) High (ON)			2.4	0.8	V
Enable Pin Input Current	$V_{EN} = 26V$	100		600 750	V
	$V_{EN} = 0.8V$			2.5 5	μA
Regulator Output Current in Shutdown	(Note 10)	10		500	μA

NOTES:

The Bold specifications apply to the full operating temperature range.

Note 1: Maximum positive supply voltage of 60V must be of limited duration (<100msec) and duty cycle.) The maximum continuous supply voltage is 26V.

Note 2: Full load current (I_{FL}) is defined as 1.25A for the LM2941.

Note 3: Dropout voltage is defined as the input-to output differential when the output voltage drops to 99% of its nominal value with $V_{OUT} + 1V$ applied to V_{IN} .

Note 4: $V_{IN} = V_{OUT (NOMINAL)} + 1V$. For example, use $V_{IN} = 4.3V$ for a 3.3V regulator. Employ pulse-testing procedures to minimize temperature rise.

Note 5: Ground pin current is the regulator quiescent current. The total current drawn from the source is the sum of the load current to the ground current.

Note 6: Output voltage temperature coefficient is defined as the worst case voltage changed divided by the total temperature range.

Note 7: Thermal regulation is defined as the change in the output voltage at a time T after a change in power dissipation is applied, excluding load or line regulation effects. Specifications are for a 200mA load pulse as $V_{IN} = 20V$ (a 4W pulse) for $T = 10ms$.

Note 8: $V_{REF} \leq V_{OUT} \leq (V_{IN} - 1)$, $2.3V \leq V_{IN} \leq 26V$, $10mA < I_L \leq I_{FL}$, $T_J \leq T_{JMAX}$

Note 9: Comparator threshold is expressed in terms of a voltage differential at the Adjust terminal below the nominal reference voltage measured 6V input. To express these thresholds in terms of output voltage change, multiply the error amplifier gain = $V_{OUT}/V_{REF} = (R1 + R2)/R2$. For example, at a programmable output voltage of 5V, the Error output is guaranteed to go low when the output drops by $95mV \times 5V / 1.240V = 38mV$. Threshold remains constant as a percent of V_{OUT} as V_{OUT} is varied, with the dropout warning occurring at typically 5% below nominal, 7.7% guaranteed.

Note 10: $V_{EN} \leq 0.8V$ and $V_{IN} \leq 26V$, $V_{OUT} = 0$.

BLOCK DIAGRAM

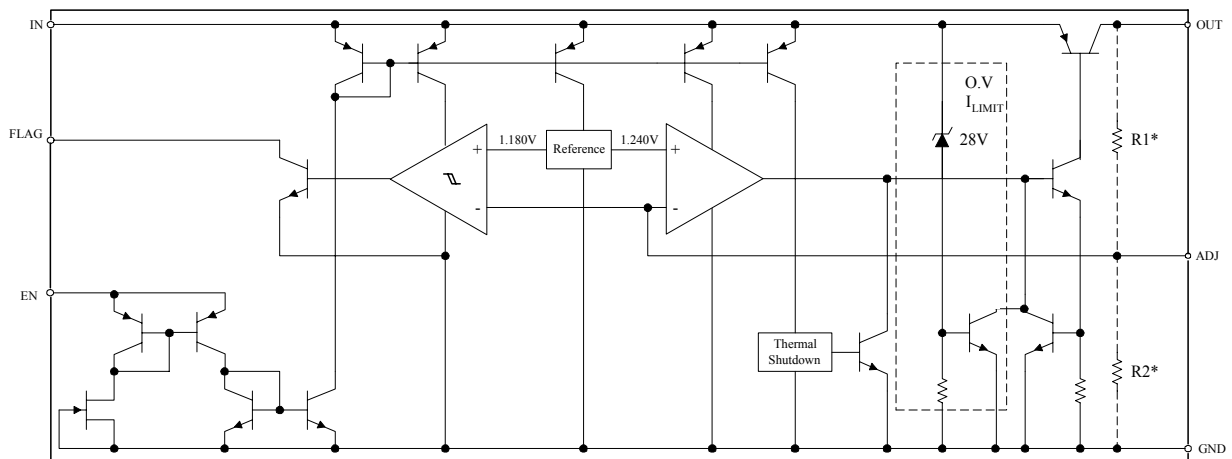

APPLICATION HINTS

The Bay Linear LM2941 incorporates protection against over-current faults, reversed load insertion, over temperature operation, and positive and negative transient voltage. However, the use of an output capacitor is required in order to insure the stability and the performances.

Thermal Consideration

Although the LM2941 offers limiting circuitry for overload conditions, it is necessary not to exceed the maximum junction temperature, and therefore to be careful about thermal resistance. The heat flow will follow the lowest resistance path, which is the Junction-to-case thermal resistance. In order to insure the best thermal flow of the component, a proper mounting is required. Note that the case of the device is electrically connected to the output. The case has to be electrically isolated, a thermally conductive spacer can be used. However do not forget to consider its contribution to thermal resistance.

Assuming:

$V_{IN} = 10V$, $V_{OUT} = 5V$, $I_{OUT} = 1.5A$, $T_A = 90^\circ C$, $\theta_{CASE} = 1^\circ C/W$ (no external heat sink, no wind)

Power dissipation under these conditions

$$P_D = (V_{IN} - V_{OUT}) * I_{OUT} = 7.5W$$

Junction Temperature

$$T_J = T_A + P_D * (\theta_{CASE} + \theta_{JC})$$

For the Control Section

$$T_J = 90^\circ C + 7.5W * (1^\circ C/W + 0.6^\circ C/W) = 102^\circ C$$

$114^\circ C < T_{JUNCTION\ MAX}$ for the control section.

For the Power Section

$$T_J = 90^\circ C + 7.5W * (1^\circ C/W + 1.6^\circ C/W) = 104.5^\circ C$$

$109.5^\circ C < T_{JUNCTION\ MAX}$ for the power transistor.

In both case reliable operation is insured by adequate junction temperature.

Capacitor Requirements

The output capacitor is needed for stability and to minimize the output noise. The required value of the capacitor varies with the load.

However, a minimum value of $10\mu F$ Aluminum will guarantee stability over load. A tantalum capacitor is recommended for a fast load transient response.

If the power source has high AC impedance, a $0.1\mu F$ capacitor between input & ground is recommended. This capacitor should have good characteristics up to 250 kHz.

Minimum Load Current

To ensure a proper behavior of the regulator at light load, a minimum load of 5mA for LM2941 is required.

Adjustable Regulator Design

B29152/53 are adjustable regulators and maybe programmed for any value between 1.25V and 26V using two resistors. The relation between the resistors is given by:

$$R_1 = R_2 (V_{OUT}/1.240 - 1)$$

Resistors have a large value up to $1m\Omega$ in order to reduce the current consumption. This might be interesting in the case of widely varying load currents.

Enable Input

LM2941 features enable input allowing turning ON & OFF the device. EN has been designed to be compatible with TTL/CMOS logic. When the regulator is ON, the current flowing through this pin is approximately $20\mu A$.

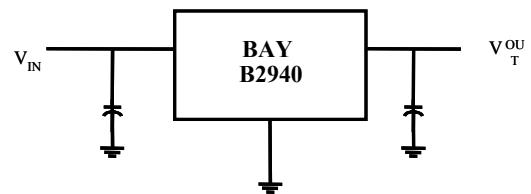
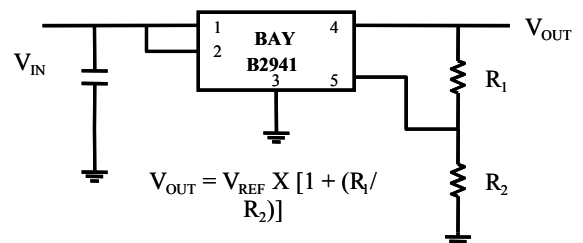

Fig.1 Basic Fixed Output Regulator



For best results, the total series resistance should be small enough to pass the minimum regulator load current

Fig. 2 Adjustable Output Voltage Regulator

Advance Information- These data sheets contain descriptions of products that are in development. The specifications are based on the engineering calculations, computer simulations and/or initial prototype evaluation.

Preliminary Information- These data sheets contain minimum and maximum specifications that are based on the initial device characterizations. These limits are subject to change upon the completion of the full characterization over the specified temperature and supply voltage ranges.

The application circuit examples are only to explain the representative applications of the devices and are not intended to guarantee any circuit design or permit any industrial property right to other rights to execute. Bay Linear takes no responsibility for any problems related to any industrial property right resulting from the use of the contents shown in the data book. Typical parameters can and do vary in different applications. Customer's technical experts must validate all operating parameters including "Typical" for each customer application.

LIFE SUPPORT AND NUCLEAR POLICY

Bay Linear products are not authorized for and should not be used within life support systems which are intended for surgical implants into the body to support or sustain life, in aircraft, space equipment, submarine, or nuclear facility applications without the specific written consent of Bay Linear President.
