

ADS7819

12-Bit 800kHz Sampling CMOS ANALOG-to-DIGITAL CONVERTER

FEATURES

- 1.25 μ s THROUGHPUT TIME
- STANDARD ± 2.5 V INPUT RANGE
- 70dB min SINAD WITH 250kHz INPUT
- $\pm 3/4$ LSB max INL AND ± 1 LSB max DNL
- INTERNAL REFERENCE
- COMPLETE WITH S/H, REF, CLOCK, ETC.
- PARALLEL DATA w/ LATCHES
- 28-PIN 0.3" PDIP AND SOIC

DESCRIPTION

The ADS7819 is a complete 12-bit sampling A/D using state-of-the-art CMOS structures. It contains a complete 12-bit capacitor-based SAR A/D with inherent S/H, reference, clock, interface for microprocessor use, and three-state output drivers.

The ADS7819 is specified at an 800kHz sampling rate, and guaranteed over the full temperature range. Laser-trimmed scaling resistors provide a ± 2.5 V input range and inherent overvoltage protection up to ± 25 V.

The 28-pin ADS7819 is available in a plastic 0.3" DIP and in an SOIC, both fully specified for operation over the industrial -40°C to $+85^{\circ}\text{C}$ range.

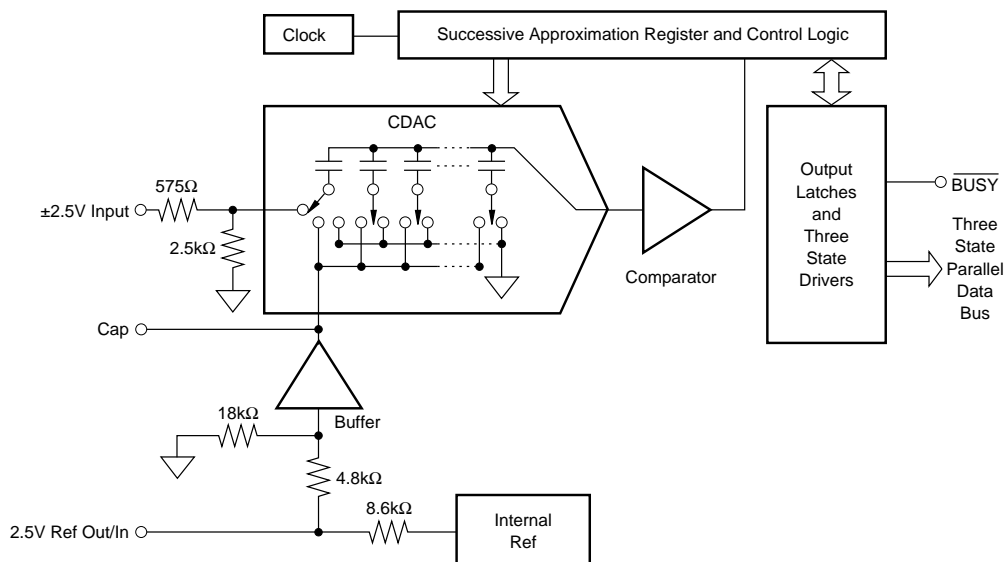

International Airport Industrial Park • Mailing Address: PO Box 11400 • Tucson, AZ 85734 • Street Address: 6730 S. Tucson Blvd. • Tucson, AZ 85706
Tel: (520) 746-1111 • Twx: 910-952-1111 • Cable: BBRCORP • Telex: 066-6491 • FAX: (520) 889-1510 • Immediate Product Info: (800) 548-6132

SPECIFICATIONS

At $T_A = -40^{\circ}\text{C}$ to $+85^{\circ}\text{C}$, $f_s = 800\text{kHz}$, $+V_{\text{DIG}} = +V_{\text{ANA}} = +5\text{V}$, $-V_{\text{ANA}} = -5\text{V}$, using internal reference and the 50Ω input resistor shown in Figure 4b, unless otherwise specified.

PARAMETER	CONDITIONS	ADS7819P, U			ADS7819PB, UB			UNITS	
		MIN	TYP	MAX	MIN	TYP	MAX		
RESOLUTION				12			*	Bits	
ANALOG INPUT									
Voltage Range			± 2.5			*		V	
Impedance			3.1			*		k Ω	
Capacitance			5			*		pF	
THROUGHPUT SPEED									
Conversion Time	Acquire & Convert		940			*		ns	
Complete Cycle				1250			*	ns	
Throughput Rate		800			*			kHz	
DC ACCURACY									
Integral Linearity Error	Ext. 2.5000V Ref Ext. 2.5000V Ref +4.75V < V_D < +5.25V -5.25V < $-V_{\text{ANA}}$ < -4.75V			± 1			± 0.75	LSB ⁽¹⁾	
Differential Linearity Error				± 1			*	LSB	
No Missing Codes			Guaranteed			*			
Transition Noise ⁽²⁾				0.1		*		LSB	
Full Scale Error ^(3, 4)					± 0.5			± 0.25	%
Full Scale Error Drift				± 12			*	*	ppm/ $^{\circ}\text{C}$
Full Scale Error ^(3, 4)					± 0.5			*	%
Full Scale Error Drift				± 12			*	*	ppm/ $^{\circ}\text{C}$
Bipolar Zero Error ⁽³⁾					± 8			± 4	LSB
Bipolar Zero Error Drift				± 2			*	*	ppm/ $^{\circ}\text{C}$
Power Supply Sensitivity ($+V_{\text{DIG}} = +V_{\text{ANA}} = V_D$)				± 5			*	LSB	
				± 0.5			*	LSB	
AC ACCURACY									
Spurious-Free Dynamic Range	$f_{\text{IN}} = 250\text{kHz}$	74	84		77	85		dB ⁽⁵⁾	
Total Harmonic Distortion	$f_{\text{IN}} = 250\text{kHz}$		-82	-74		-83	-77	dB	
Signal-to-(Noise+Distortion)	$f_{\text{IN}} = 250\text{kHz}$	68	71		70	*		dB	
Signal-to-Noise	$f_{\text{IN}} = 250\text{kHz}$	68	71		70	*		dB	
Usable Bandwidth ⁽⁶⁾			1.5			*		MHz	
SAMPLING DYNAMICS									
Aperture Delay	FS Step		20			*		ns	
Aperture Jitter			10			*		ps	
Transient Response			180			*		ns	
Overvoltage Recovery ⁽⁷⁾			250			*		ns	
REFERENCE									
Internal Reference Voltage		2.48	2.5	2.52	*	*	*	V	
Internal Reference DC Source Current (External load should be static)			100			*		μA	
Internal Reference Drift			6					ppm/ $^{\circ}\text{C}$	
External Reference Voltage Range For Specified Linearity		2.3	2.5	2.7	*	*	*	V	
External Reference Current Drain	Ext. 2.5000V Ref			100			*	μA	
DIGITAL INPUTS									
Logic Levels	$V_{\text{IL}} = 0\text{V}$ $V_{\text{IH}} = 5\text{V}$								
V_{IL}		-0.3		+0.8	*		*	V	
V_{IH}		+2.4		$V_D + 0.3$	*		*	V	
I_{IL}				± 10			*	μA	
I_{IH}				± 10			*	μA	
DIGITAL OUTPUTS									
Data Format									
Data Coding									
V_{OL}	$I_{\text{SINK}} = 1.6\text{mA}$ $I_{\text{SOURCE}} = 500\mu\text{A}$ High-Z State, $V_{\text{OUT}} = 0\text{V}$ to V_{DIG} High-Z State								
V_{OH}		+2.8		+0.4	*		*	V	
Leakage Current				± 5			*	μA	
Output Capacitance				15			*	pF	
DIGITAL TIMING									
Bus Access Time				62			*	ns	
Bus Relinquish Time				83			*	ns	

The information provided herein is believed to be reliable; however, BURR-BROWN assumes no responsibility for inaccuracies or omissions. BURR-BROWN assumes no responsibility for the use of this information, and all use of such information shall be entirely at the user's own risk. Prices and specifications are subject to change without notice. No patent rights or licenses to any of the circuits described herein are implied or granted to any third party. BURR-BROWN does not authorize or warrant any BURR-BROWN product for use in life support devices and/or systems.



SPECIFICATIONS (CONT)

At $T_A = -40^{\circ}\text{C}$ to $+85^{\circ}\text{C}$, $f_s = 800\text{kHz}$, $+V_{\text{DIG}} = +V_{\text{ANA}} = +5\text{V}$, $-V_{\text{ANA}} = -5\text{V}$, using internal reference and the 50Ω input resistor shown in Figure 4b, unless otherwise specified.

PARAMETER	CONDITIONS	ADS7819P, U			ADS7819PB, UB			UNITS
		MIN	TYP	MAX	MIN	TYP	MAX	
POWER SUPPLIES								
Specified Performance								
$+V_{\text{DIG}} = +V_{\text{ANA}}$		+4.75	+5	+5.25	*	*	*	V
$-V_{\text{ANA}}$		-5.25	-5	-4.75	*	*	*	V
$+I_{\text{DIG}}$			+16			*		mA
$+I_{\text{ANA}}$			+16			*		mA
$-I_{\text{ANA}}$			-13			*		mA
Derated Performance								
$+V_{\text{DIG}} = +V_{\text{ANA}}$		+4.5	+5	+5.5	*	*	*	V
$-V_{\text{ANA}}$		-5.5	-5	-4.5	*	*	*	V
Power Dissipation	$f_s = 800\text{kHz}$		225	275			*	mW
TEMPERATURE RANGE								
Specified Performance								
Derated Performance								
Storage								
Thermal Resistance (θ_{JA})		-40		+85	*		*	$^{\circ}\text{C/W}$
Plastic DIP		-55		+125	*		*	$^{\circ}\text{C/W}$
SOIC		-65		+150	*		*	$^{\circ}\text{C/W}$
			75			*		$^{\circ}\text{C/W}$
			75			*		$^{\circ}\text{C/W}$

NOTES: (1) LSB means Least Significant Bit. For the 12-bit, $\pm 2.5\text{V}$ input ADS7819, one LSB is 1.22mV. (2) Typical rms noise at worst case transitions and temperatures. (3) Measured with 50Ω in series with analog input. Adjustable to zero with external potentiometer. (4) Full scale error is the worst case of -Full Scale or +Full Scale untrimmed deviation from ideal first and last code transitions, divided by the transition voltage (not divided by the full-scale range) and includes the effect of offset error. (5) All specifications in dB are referred to a full-scale $\pm 2.5\text{V}$ input. (6) Usable Bandwidth defined as Full-Scale input frequency at which Signal-to-(Noise+Distortion) degrades to 60dB, or 10 bits of accuracy. (7) Recovers to specified performance after $2 \times \text{FS}$ input over voltage.

ABSOLUTE MAXIMUM RATINGS

Analog Inputs: V_{IN}	$\pm 25\text{V}$
REF	$+V_{\text{ANA}} + 0.3\text{V}$ to AGND2 -0.3V
CAP	Indefinite Short to AGND2
Momentary Short to $+V_{\text{ANA}}$	
Ground Voltage Differences: DGND, AGND1, AGND2	$\pm 0.3\text{V}$
$+V_{\text{ANA}}$	$+7\text{V}$
$+V_{\text{DIG}}$ to $+V_{\text{ANA}}$	$+0.3\text{V}$
$+V_{\text{DIG}}$	7V
$-V_{\text{ANA}}$	-7V
Digital Inputs	-0.3V to $+V_{\text{DIG}} + 0.3\text{V}$
Maximum Junction Temperature	$+165^{\circ}\text{C}$
Internal Power Dissipation	825mW
Lead Temperature (soldering, 10s)	$+300^{\circ}\text{C}$



ELECTROSTATIC DISCHARGE SENSITIVITY

Electrostatic discharge can cause damage ranging from performance degradation to complete device failure. Burr-Brown Corporation recommends that all integrated circuits be handled and stored using appropriate ESD protection methods.

ORDERING AND PACKAGE INFORMATION

MODEL	MAXIMUM INTEGRAL LINEARITY ERROR (LSB)	MINIMUM SIGNAL-TO-(NOISE + DISTORTION) RATIO (dB)	SPECIFICATION TEMPERATURE RANGE	PACKAGE	PACKAGE DRAWING NUMBER ⁽¹⁾
ADS7819P	± 1	68	-40°C to $+85^{\circ}\text{C}$	28-Pin Plastic DIP	246
ADS7819PB	± 0.75	70	-40°C to $+85^{\circ}\text{C}$	28-Pin Plastic DIP	246
ADS7819U	± 1	68	-40°C to $+85^{\circ}\text{C}$	28-Pin SOIC	217
ADS7819UB	± 0.75	70	-40°C to $+85^{\circ}\text{C}$	28-Pin SOIC	217

NOTE: (1) For detailed drawing and dimension table, please see end of data sheet, or Appendix D of Burr-Brown IC Data Book.

PIN ASSIGNMENTS

PIN #	NAME	DIGITAL I/O	DESCRIPTION
1	V _{IN}		Analog Input. Connect via 50Ω to analog input. Full-scale input range is ±2.5V.
2	AGND1		Analog Ground. Used internally as ground reference point. Minimal current flow.
3	REF		Reference Input/Output. Outputs internal reference of +2.5V nominal. Can also be driven by external system reference. In both cases, decouple to ground with a 0.1μF ceramic capacitor.
4	CAP		Reference Buffer Output. 10μF tantalum capacitor to ground. Nominally +2V.
5	AGND2		Analog Ground.
6	D11 (MSB)	O	Data Bit 11. Most Significant Bit (MSB) of conversion results. Hi-Z state when \overline{CS} is HIGH, or when R/\overline{C} is LOW, or when a conversion is in progress.
7	D10	O	Data Bit 10. Hi-Z state when \overline{CS} is HIGH, or when R/\overline{C} is LOW, or when a conversion is in progress.
8	D9	O	Data Bit 9. Hi-Z state when \overline{CS} is HIGH, or when R/\overline{C} is LOW, or when a conversion is in progress.
9	D8	O	Data Bit 8. Hi-Z state when \overline{CS} is HIGH, or when R/\overline{C} is LOW, or when a conversion is in progress.
10	D7	O	Data Bit 7. Hi-Z state when \overline{CS} is HIGH, or when R/\overline{C} is LOW, or when a conversion is in progress.
11	D6	O	Data Bit 6. Hi-Z state when \overline{CS} is HIGH, or when R/\overline{C} is LOW, or when a conversion is in progress.
12	D5	O	Data Bit 5. Hi-Z state when \overline{CS} is HIGH, or when R/\overline{C} is LOW, or when a conversion is in progress.
13	D4	O	Data Bit 4. Hi-Z state when \overline{CS} is HIGH, or when R/\overline{C} is LOW, or when a conversion is in progress.
14	DGND		Digital Ground.
15	D3	O	Data Bit 3. Hi-Z state when \overline{CS} is HIGH, or when R/\overline{C} is LOW, or when a conversion is in progress.
16	D2	O	Data Bit 2. Hi-Z state when \overline{CS} is HIGH, or when R/\overline{C} is LOW, or when a conversion is in progress.
17	D1	O	Data Bit 1. Hi-Z state when \overline{CS} is HIGH, or when R/\overline{C} is LOW, or when a conversion is in progress.
18	D0 (LSB)	O	Data Bit 0. Least Significant Bit (LSB) of conversion results. Hi-Z state when \overline{CS} is HIGH, or when R/\overline{C} is LOW, or when a conversion is in progress.
19			Not internally connected.
20	+V _{ANA}		Analog Positive Supply Input. Nominally +5V. Connect directly to pins 21, 27 and 28.
21	+V _{DIG}		Digital Supply Input. Nominally +5V. Connect directly to pins 20, 27 and 28.
22	DGND		Digital ground.
23	R/ \overline{C}	I	Read/Convert Input. With \overline{CS} LOW, a falling edge on R/\overline{C} puts the internal sample/hold into the hold state and starts a conversion. With \overline{CS} LOW and no conversion in progress, a rising edge on R/\overline{C} enables the output data bits.
24	\overline{CS}	I	Chip Select. With R/\overline{C} LOW, a falling edge on \overline{CS} will initiate a conversion. With R/\overline{C} HIGH and no conversion in progress, a falling edge on \overline{CS} will enable the output data bits.
25	\overline{BUSY}	O	Busy Output. Falls when a conversion is started, and remains LOW until the conversion is completed and the data is latched into the output register. With \overline{CS} LOW and R/\overline{C} HIGH, output data will be valid when \overline{BUSY} rises, so that the rising edge can be used to latch the data.
26	-V _{ANA}		Analog Negative Supply Input. Nominally -5V. Decouple to ground with 0.1μF ceramic and 10μF tantalum capacitors.
27	+V _{DIG}		Digital Supply Input. Nominally +5V. Connect directly to pins 20, 21 and 28.
28	+V _{ANA}		Analog Positive Supply Input. Nominally +5V. Connect directly to pins 20, 21 and 27, and decouple to ground with 0.1μF ceramic and 10μF tantalum capacitors.

PIN CONFIGURATION

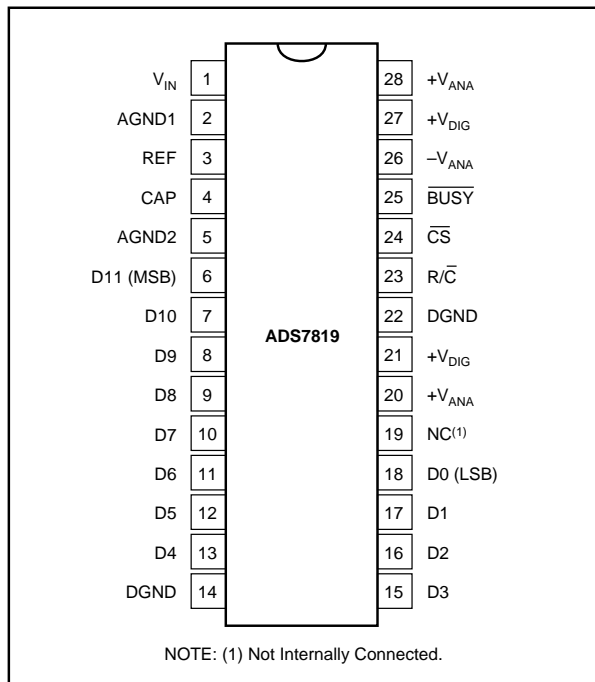

TYPICAL PERFORMANCE CURVES

T = +25°C, $f_S = 800\text{kHz}$, $V_{\text{DIG}} = +V_{\text{ANA}} = +5\text{V}$, $-V_{\text{ANA}} = -5\text{V}$, using internal reference and the input 50Ω resistors as shown in Figure 4b, unless otherwise specified.

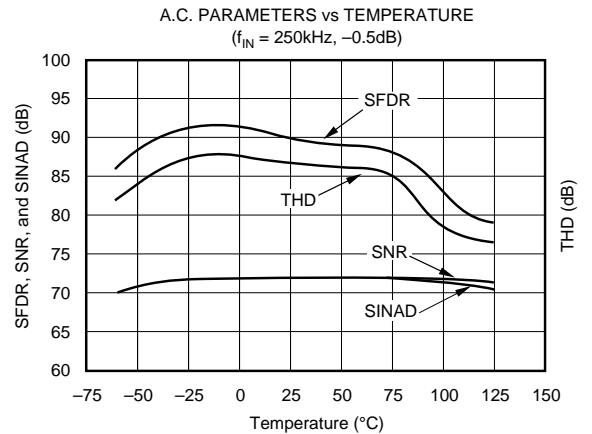
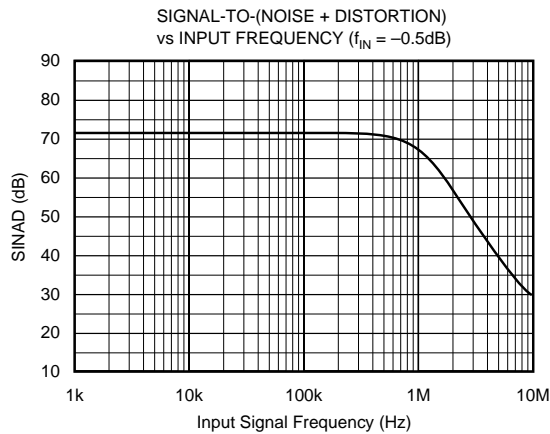
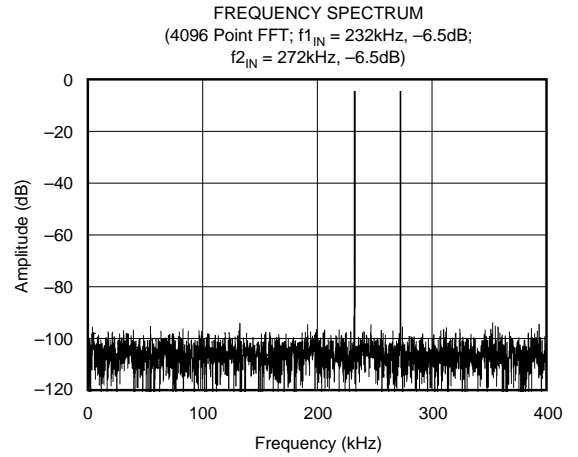
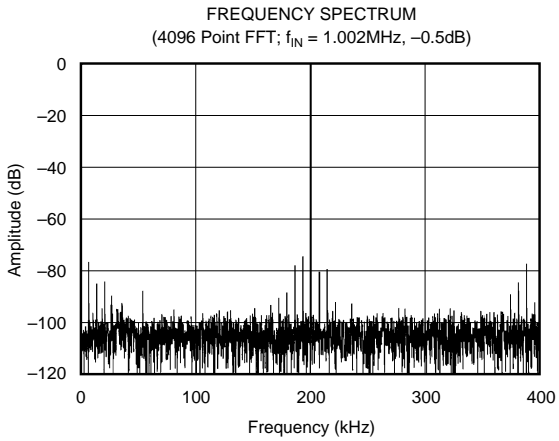
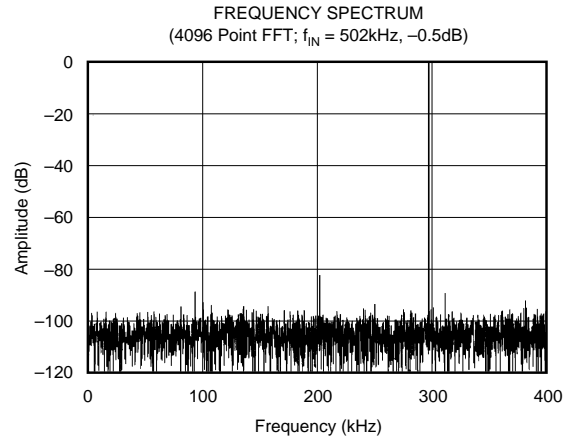
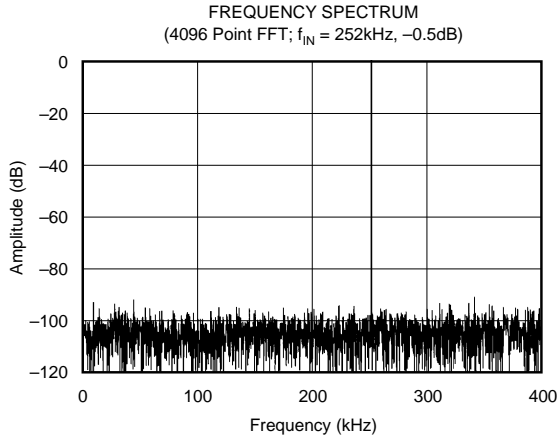

TYPICAL PERFORMANCE CURVES (CONT)

T = +25°C, f_S = 800kHz, +V_{DIG} = +V_{ANA} = +5V, -V_{ANA} = -5V, using internal reference and the 50Ω input resistors as shown in Figure 4b, unless otherwise specified.

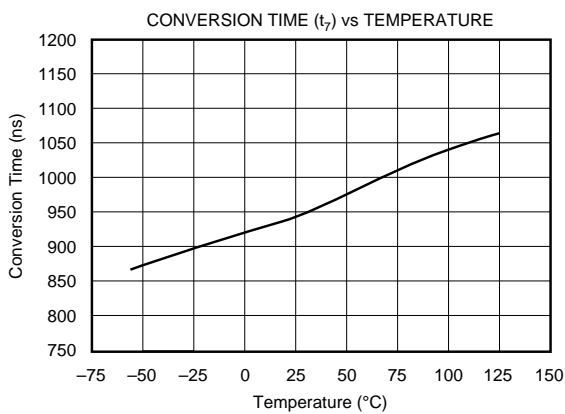
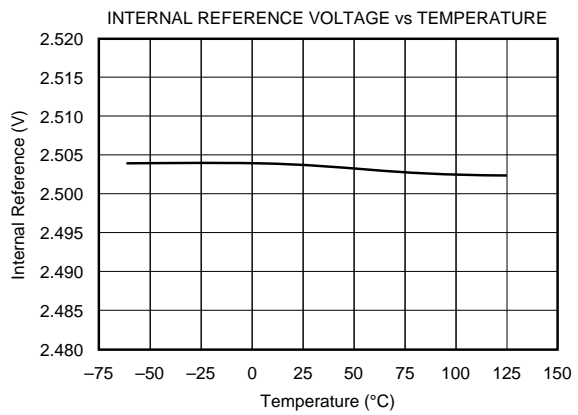
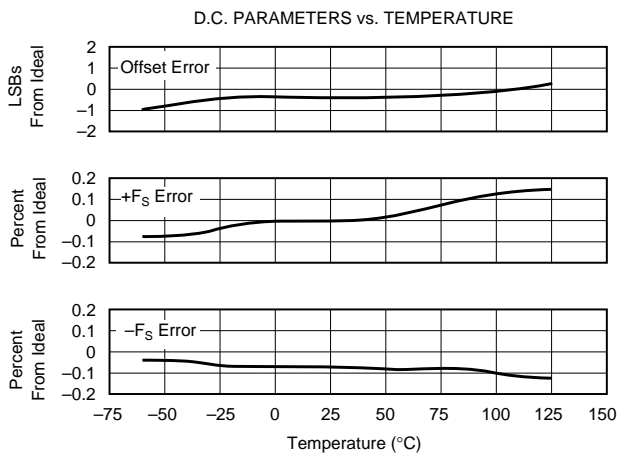
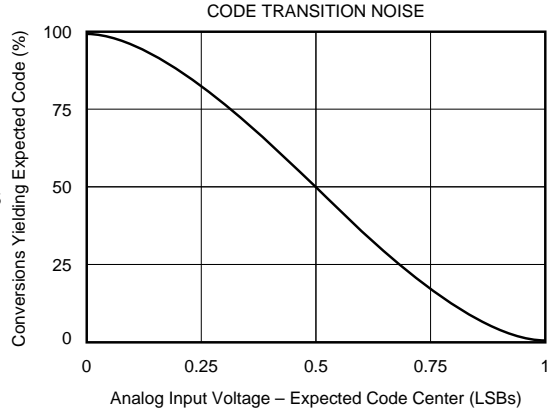
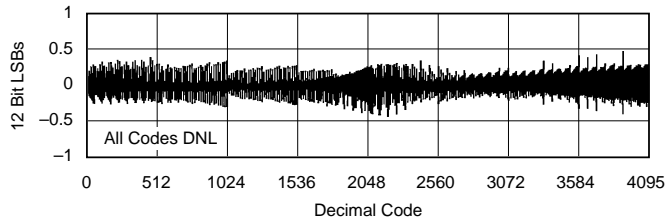
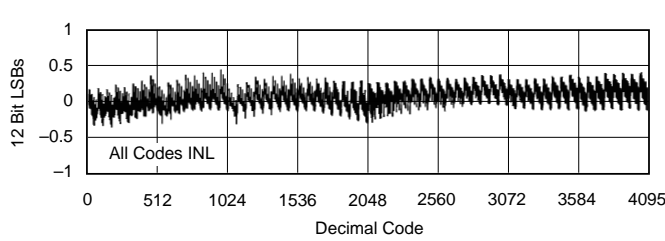

BASIC OPERATION

Figure 1 shows a basic circuit to operate the ADS7819. Taking $\overline{R/C}$ (pin 23) LOW for 40ns will initiate a conversion. \overline{BUSY} (pin 25) will go LOW and stay LOW until the conversion is completed and the output registers are updated. Data will be output in Binary Two's Complement with the MSB on D11 (pin 6). \overline{BUSY} going HIGH can be used to latch the data. All convert commands will be ignored while \overline{BUSY} is LOW.

\overline{CS}	$\overline{R/C}$	\overline{BUSY}	OPERATION
1	X	X	None. Databus in Hi-Z state.
↓	0	1	Initiates conversion. Databus remains in Hi-Z state.
0	↓	1	Initiates conversion. Databus enters Hi-Z state.
0	1	↑	Conversion completed. Valid data from the most recent conversion on the databus.
↓	1	1	Enables databus with valid data from the most recent conversion.
↓	1	0	Conversion in progress. Databus in Hi-Z state, enabled when the conversion is completed.
0	↑	0	Conversion in progress. Databus in Hi-Z state, enabled when the conversion is completed.
0	0	↑	Conversion completed. Valid data from the most recent conversion in the output register but the output pins D11-D0 are tri-stated.
X	X	0	New convert commands ignored. Conversion in progress.

Table I. Control Line Functions for 'read' and 'convert'.

The ADS7819 will begin tracking the input signal at the end of the conversion. Allowing 1.25 μ s between convert commands assures accurate acquisition of a new signal.

STARTING A CONVERSION

The combination of \overline{CS} (pin 24) and $\overline{R/C}$ (pin 23) LOW for a minimum of 40ns puts the sample/hold of the ADS7819 in the hold state and starts a conversion. \overline{BUSY} (pin 25) will go LOW and stay LOW until the conversion is completed and the internal output register has been updated. All new convert commands during \overline{BUSY} LOW will be ignored.

The ADS7819 will begin tracking the input signal at the end of the conversion. Allowing 1.25 μ s between convert commands assures accurate acquisition of a new signal. Refer to Table I for a summary of \overline{CS} , $\overline{R/C}$, and \overline{BUSY} states and Figures 2 and 3 for timing parameters.

DESCRIPTION	ANALOG VALUE	DIGITAL OUTPUT	
		BINARY CODE	HEX CODE
Full Scale Range	$\pm 2.5V$	BINARY TWO'S COMPLEMENT	
Least Significant Bit (LSB)	1.22mV		
+Full Scale (2.5V - 1LSB)	2.499V	0111 1111 1111	7FF
Midscale	0V	0000 0000 0000	000
One LSB below Midscale	-1.22mV	1111 1111 1111	FFF
-Full Scale	-2.5V	1000 0000 0000	800

TABLE II. Ideal Input Voltages and Output Codes.

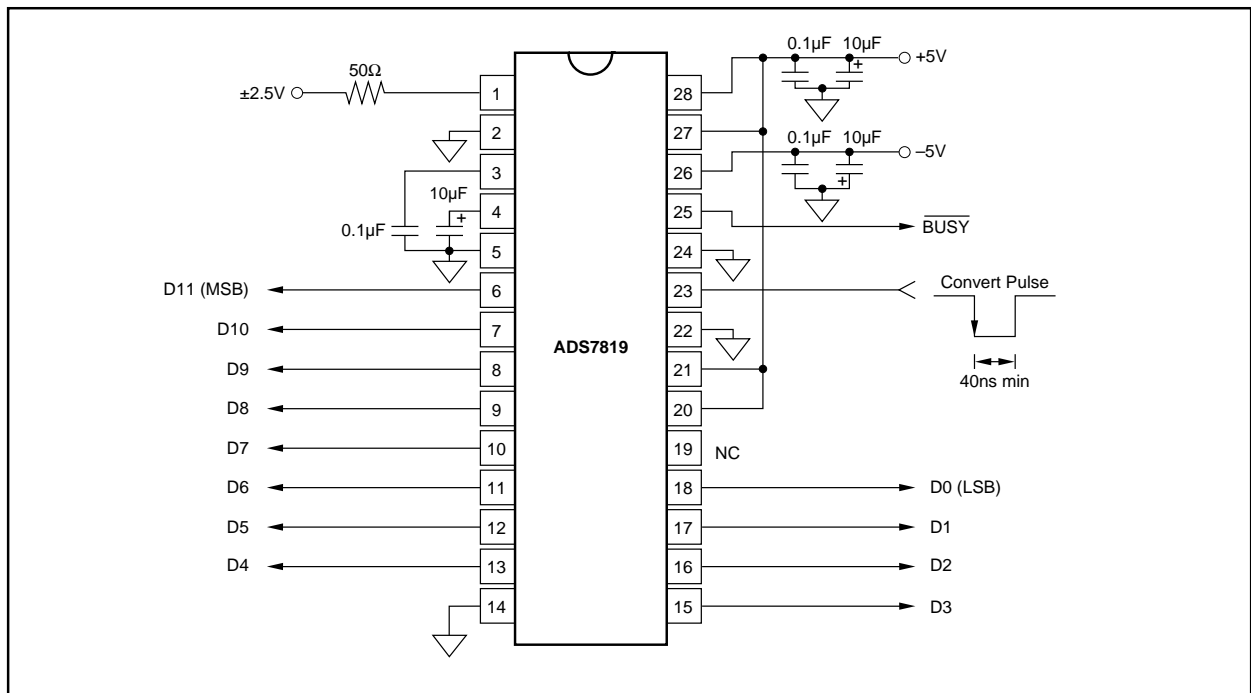

FIGURE 1. Basic Operation

\overline{CS} and R/\overline{C} are internally OR'd and level triggered. There is not a requirement which input goes LOW first when initiating a conversion. If it is critical that \overline{CS} or R/\overline{C} initiate the conversion, be sure the less critical input is LOW at least 10ns prior to the initiating input.

To reduce the number of control pins, \overline{CS} can be tied LOW using R/\overline{C} to control the read and convert modes. Note that the parallel output will be active whenever R/\overline{C} is HIGH and no conversion is in progress. See the **Reading Data** section and refer to Table I for control line functions for 'read' and 'convert' modes.

READING DATA

The ADS7819 outputs full parallel data in Binary Two's Complement data format. The parallel output will be active when R/\overline{C} (pin 23) is HIGH, \overline{CS} (pin 24) is LOW, and no conversion is in progress. Any other combination will tri-state the parallel output. Valid conversion data can be read in a full parallel, 12-bit word on D11-D0 (pins 6-13 and 15-18). Refer to Table II for ideal output codes.

After the conversion is completed and the output registers have been updated, \overline{BUSY} (pin 25) will go HIGH. Valid data from the most recent conversion will be available on D11-D0 (pins 6-13 and 15-18). \overline{BUSY} going HIGH can be used to latch the data. Refer to Table III and Figures 2 and 3.

Note: For best performance, the external data bus connected to D11-D0 should not be active during a conversion. The switching noise of the external asynchronous data signals can cause digital feed through degrading the converter's performance.

The number of control lines can be reduced by tying \overline{CS} LOW while using R/\overline{C} to initiate conversions and activate the output mode of the converter. See Figure 2.

INPUT RANGES

The ADS7819 has a $\pm 2.5V$ input range. Figures 4a and 4b show the necessary circuit connections for the ADS7819 with and without external hardware trim. Offset and full scale error⁽¹⁾ specifications are tested and guaranteed with the 50 Ω resistor shown in Figure 4b. This external resistor makes it possible to trim the offset $\pm 12mV$ using a trim pot or trim DAC. This resistor may be left out if the offset and gain errors will be corrected in software or if they are negligible in regards to the particular application. See the **Calibration** section of the data sheet for details.

The nominal input impedance of 3.125k Ω results from the combination of the internal resistor network shown on the front page of the product data sheet and the external 50 Ω resistor. The input resistor divider network provides inherent over-voltage protection guaranteed to at least $\pm 25V$. The 50 Ω , 1% resistor does not compromise the accuracy or drift of the converter. It has little influence relative to the internal resistors, and tighter tolerances are not required.

Note: The values shown for the internal resistors are for reference only. The exact values can vary by $\pm 30\%$. This is true of all resistors internal to the ADS7819. Each resistive divider is trimmed so that the proper division is achieved.

NOTE: (1) Full scale error includes offset and gain errors and is measured at both +FS and -FS.

SYMBOL	DESCRIPTION	MIN	TYP	MAX	UNITS
t_1	Convert Pulse Width	40			ns
t_2	Data Valid Delay After Start of Conversion		965	1100	ns
t_3	\overline{BUSY} Delay From Start of Conversion		70	125	ns
t_4	\overline{BUSY} LOW		960	1085	ns
t_5	\overline{BUSY} Delay After End of Conversion		90		ns
t_6	Aperture Delay		20		ns
t_7	Conversion Time		940	1030	ns
t_8	Acquisition Time		180	220	ns
t_7 & t_8	Throughput Time		1120	1250	ns
t_9	Bus Relinquish Time	10	50	83	ns
t_{10}	\overline{BUSY} Delay After Data Valid	20	65	100	ns
t_{11}	R/\overline{C} to \overline{CS} Setup Time	10			ns
t_{12}	Time Between Conversions	1250			ns
t_{13}	Bus Access Time	10	30	62	ns

TABLE III. Timing Specifications (T_{MIN} to T_{MAX}).

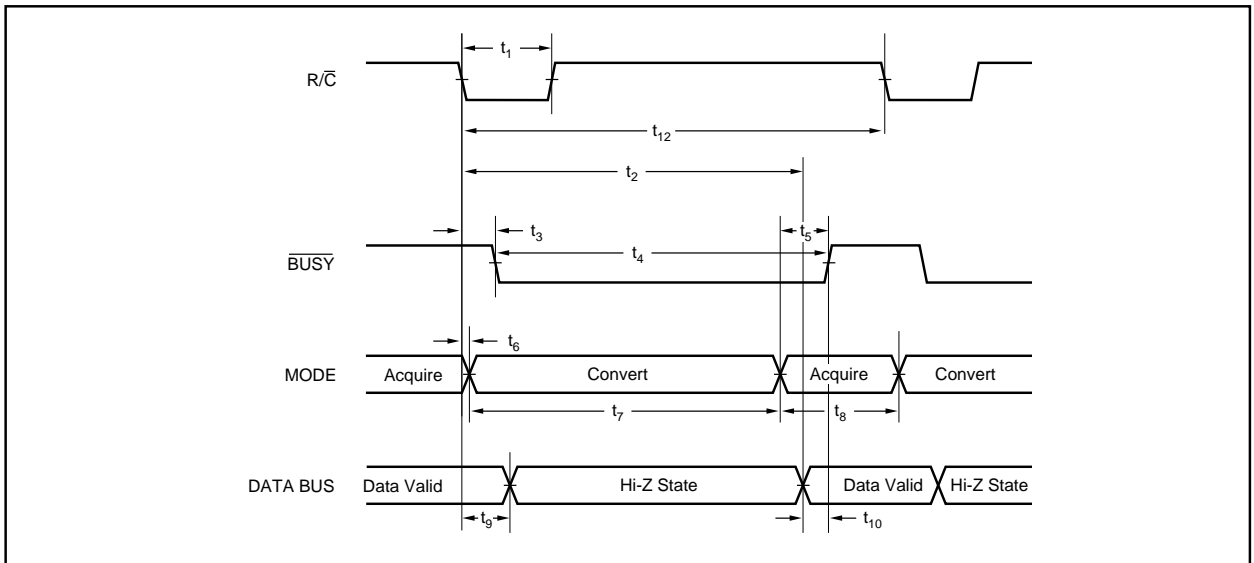

FIGURE 2. Conversion Timing with Outputs Enabled After Conversion (\overline{CS} Tied Low).

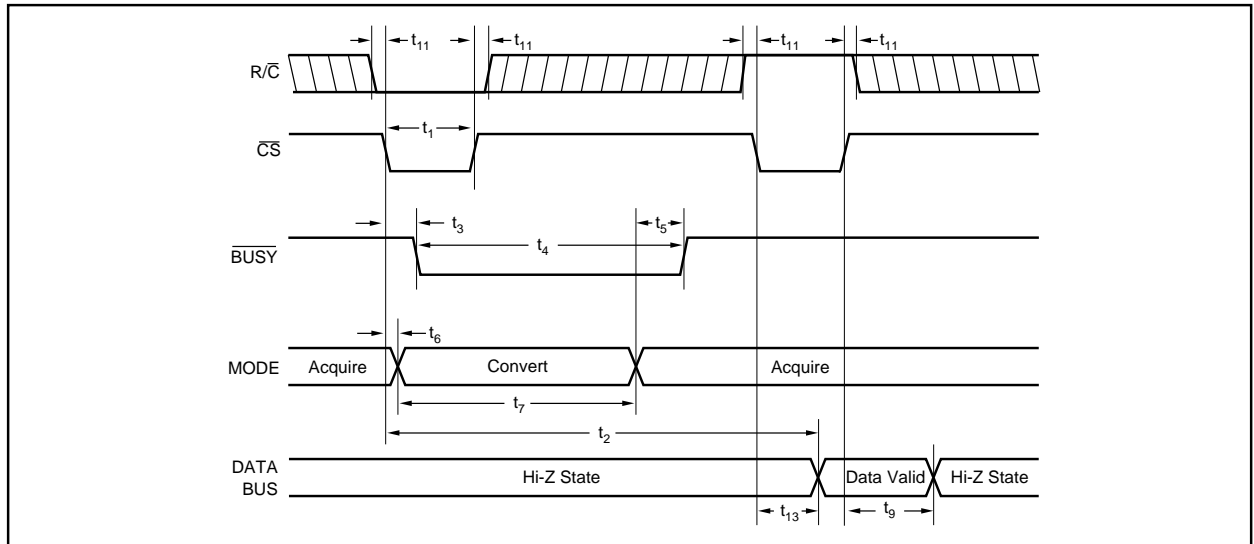

FIGURE 3. Using \overline{CS} to Control Conversion and Read Timing.

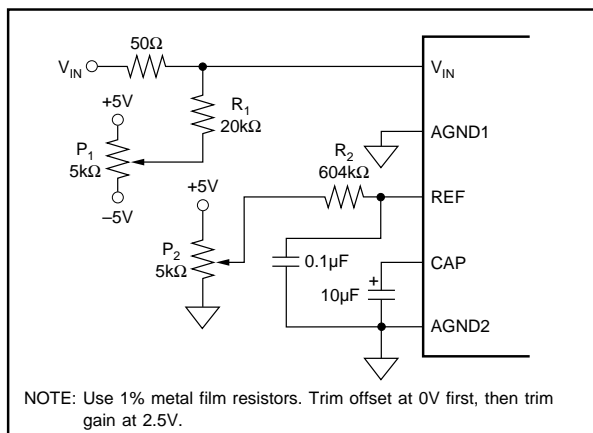

FIGURE 4a. Circuit Diagram With External Hardware Trim.

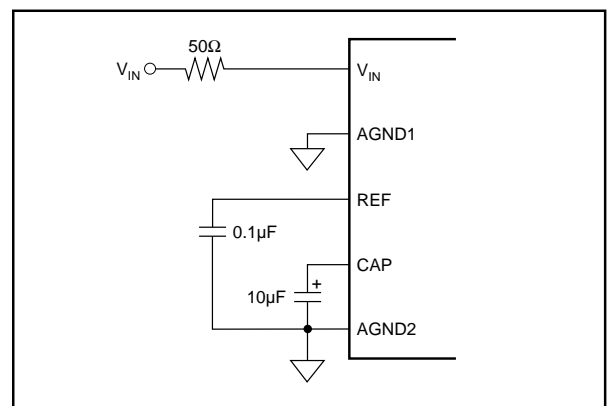

FIGURE 4b. Circuit Diagram Without External Hardware Trim.

CALIBRATION

The ADS7819 can be trimmed in hardware or software. The offset should be trimmed before the gain since the offset directly affects the gain.

Hardware Calibration

To calibrate the offset and gain of the ADS7819, install the proper resistors and potentiometers as shown in Figure 4a. The calibration range is $\pm 12\text{mV}$ for bipolar zero and $\pm 30\text{mV}$ for full scale.

Potentiometer P_1 and resistor R_1 form the offset adjust circuit and P_2 and R_2 the gain adjust circuit. The exact values are not critical. R_1 and R_2 should not be made any larger than the value shown. They can easily be made smaller to provide increased adjustment range. Reducing these below 15% of the indicated values could begin to adversely affect the operation of the converter.

P_1 and P_2 can also be made larger to reduce power dissipation. However, larger resistances will push the useful adjustment range to the edges of the potentiometer. P_1 should probably not exceed $20\text{k}\Omega$ and P_2 $100\text{k}\Omega$ in order to maintain reasonable sensitivity.

Software Calibration

To calibrate the offset and gain of the ADS7819, no external resistors are required. See the **No Calibration** section for details on the effects of the external resistor.

No Calibration

See Figure 4b for circuit connections. Note that the actual voltage dropped across the 50Ω resistor is nearly two orders of magnitude lower than the voltage dropped across the internal resistor divider network. This should be taken into consideration when choosing the accuracy and drift specifications of the external resistors. In most applications, 1% metal-film resistors will be sufficient.

The external 50Ω resistor shown in Figure 4b may not be necessary in some applications. This resistor provides trim capability for the offset and compensates for a slight gain adjustment internal to the ADS7819. Not using the 50Ω resistor will cause a small gain error but will have no effect on the inherent offset error. Figure 5 shows typical transfer function characteristics with and without the 50Ω resistor in the circuit.

REFERENCE

The ADS7819 can operate with its internal 2.5V reference or an external reference. By applying an external reference to pin 3, the internal reference can be bypassed. The reference voltage at REF is buffered internally and output on CAP (pin 4).

The internal reference has a $6\text{ ppm}/^\circ\text{C}$ drift (typical) and accounts for approximately 20% of the full scale error (FSE = $\pm 0.5\%$ for low grade, $\pm 0.25\%$ for high grade.)

REF

REF (pin 3) is an input for an external reference or the output for the internal 2.5V reference. A $0.1\mu\text{F}$ capacitor should be connected as close to the REF pin as possible. The capacitor and the output resistance of REF create a low pass filter to band limit noise on the reference. Using a smaller value capacitor will introduce more noise to the reference degrading the SNR and SINAD. The REF pin should not be used to drive external AC or DC loads.

The range for the external reference is 2.3V to 2.7V and determines the actual LSB size. Increasing the reference voltage will increase the full scale range and the LSB size of the converter which can improve the SNR.

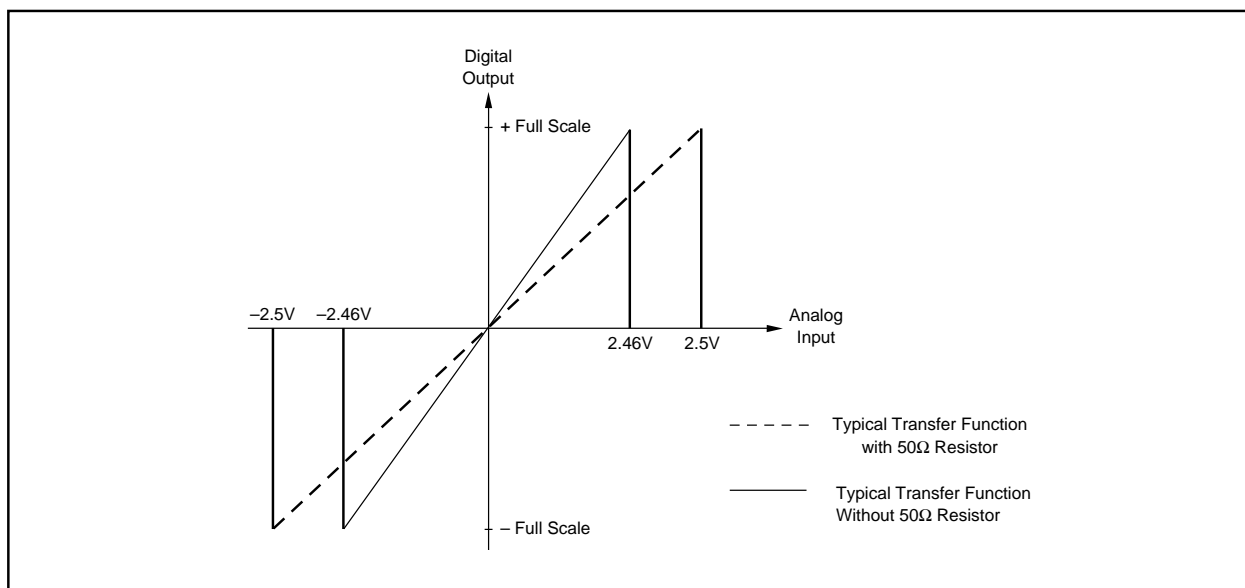

FIGURE 5. Circuit Diagram With and Without External Resistors.

CAP

CAP (pin 4) is the output of the internal reference buffer. A 10 μ F tantalum capacitor should be placed as close to the CAP as possible to provide optimum switching currents for the CDAC throughout the conversion cycle and compensation for the output of the buffer. Using a capacitor any smaller than 1 μ F can cause the output buffer to oscillate and may not have sufficient charge for the CDAC. Capacitor values larger than 10 μ F will have little effect on improving performance. The voltage on the CAP pin is approximately 2V when using the internal reference, or 80% of an externally supplied reference.

LAYOUT

POWER

The ADS7819 uses the majority of its power for analog and static circuitry, and it should be considered as an analog component. For optimum performance, tie the analog and digital +5V power pins to the same +5V power supply and tie the analog and digital grounds together.

For best performance, the \pm 5V supplies can be produced from whatever analog supply is used for the rest of the analog signal conditioning. If \pm 12V or \pm 15V supplies are present, simple regulators can be used. The +5V power for the A/D should be separate from the +5V used for the system's digital logic. Connecting +V_{DIG} (pin 27) directly to a digital supply can reduce converter performance due to switching noise from the digital logic.

Although it is not suggested, if the digital supply must be used to power the converter, be sure to properly filter the supply. Either using a filtered digital supply or a regulated analog supply, both V_{DIG} and V_{ANA} should be tied to the same +5V source.

GROUNDING

Three ground pins are present on the ADS7819. DGND (pin 22) is the digital supply ground. AGND2 (pin 5) is the analog supply ground. AGND1 (pin 2) is the ground which all analog signals internal to the A/D are referenced. AGND1 is more susceptible to current induced voltage drops and must have the path of least resistance back to the power supply.

All the ground pins of the ADS should be tied to the analog ground plane, separated from the system's digital logic ground, to achieve optimum performance. Both analog and digital ground planes should be tied to the "system" ground as near to the power supplies as possible. This helps to prevent dynamic digital ground currents from modulating the analog ground through a common impedance to power ground.

SIGNAL CONDITIONING

The FET switches used for the sample hold on many CMOS A/D converters release a significant amount of charge injection which can cause the driving op amp to oscillate. The FET switch on the ADS7819, compared to FET switches on

other CMOS A/D converters, releases 5%—10% of the charge. There is also a resistive front end which attenuates any charge which is released. The end result is a minimal requirement for the op amp on the front end. Any op amp sufficient for the signal in an application will be sufficient to drive the ADS7819.

The resistive front end of the ADS7819 also provides a guaranteed \pm 25V over voltage protection. In most cases, this eliminates the need for external input protection circuitry.

INTERMEDIATE LATCHES

The ADS7819 does have tri-state outputs for the parallel port, but intermediate latches should be used if the bus will be active during conversions. If the bus is not active during conversions, the tri-state outputs can be used to isolate the A/D from other peripherals on the same bus.

Intermediate latches are beneficial on any monolithic A/D converter. The ADS7819 has an internal LSB size of 610 μ V. Transients from fast switching signals on the parallel port, even when the A/D is tri-stated, can be coupled through the substrate to the analog circuitry causing degradation of converter performance.