



# ADS7846

For most current data sheet and other product information, visit [www.burr-brown.com](http://www.burr-brown.com)

## TOUCH-SCREEN CONTROLLER

### FEATURES

- SAME PINOUT AS ADS7843
- 2.2V TO 5.25V OPERATION
- INTERNAL 2.5V REFERENCE
- DIRECT BATTERY MEASUREMENT (0V to 6V)
- ON-CHIP TEMPERATURE MEASUREMENT
- TOUCH-PRESSURE MEASUREMENT
- QSPI/SPI 3-WIRE INTERFACE
- AUTO POWER DOWN
- TSSOP-16 AND SSOP-16 PACKAGES

### APPLICATIONS

- PERSONAL DIGITAL ASSISTANTS
- PORTABLE INSTRUMENTS
- POINT-OF-SALES TERMINALS
- PAGERS
- TOUCH-SCREEN MONITORS
- CELLULAR PHONES

### DESCRIPTION

The ADS7846 is a next-generation version to the industry standard ADS7843 4-wire touch-screen controller. The ADS7846 is 100% pin-compatible with the existing ADS7843, and will drop into the same socket. This allows for easy upgrade of current applications to the new version. Only software changes will be required to take advantage of the added features of direct battery measurement, temperature measurement, and touch-pressure measurement. The ADS7846 also has an on-chip 2.5V reference that can be utilized for the auxiliary input, battery monitor, and temperature measurement modes. The reference can also be powered down when not used to conserve power. The internal reference will operate down to 2.7V supply voltage while monitoring the battery voltage from 0V to 6V.

The low power consumption of  $< 0.5\text{mW}$  typ at 2.7V (reference OFF), high speed ( $> 125\text{kHz}$  clock rate), and on-chip drivers make the ADS7846 an ideal choice for battery-operated systems such as Personal Digital Assistants (PDAs) with resistive touch screens, pagers, cellular phones, and other portable equipment. The ADS7846 is available in the small TSSOP-16 and SSOP-16 packages and is guaranteed over the  $-40^{\circ}\text{C}$  to  $+85^{\circ}\text{C}$  temperature range.

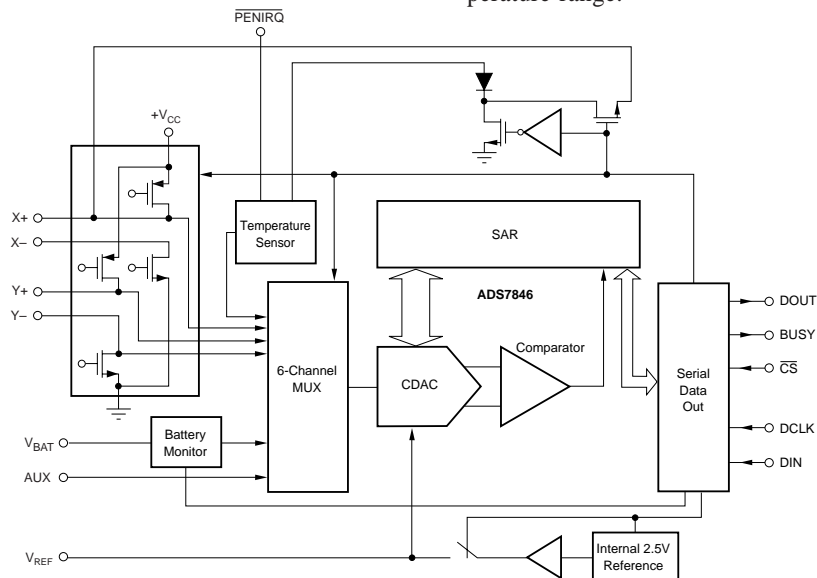

International Airport Industrial Park • Mailing Address: PO Box 11400, Tucson, AZ 85734 • Street Address: 6730 S. Tucson Blvd., Tucson, AZ 85706 • Tel: (520) 746-1111  
Tw: 910-952-1111 • Internet: <http://www.burr-brown.com/> • Cable: BBRCORP • Telex: 066-6491 • FAX: (520) 889-1510 • Immediate Product Info: (800) 548-6132

# PRELIMINARY SPECIFICATIONS

At  $T_A = -40^\circ\text{C}$  to  $+85^\circ\text{C}$ ,  $+V_{CC} = +2.7\text{V}$ ,  $V_{REF} = 2.5\text{V}$  internal voltage,  $f_{SAMPLE} = 125\text{kHz}$ ,  $f_{CLK} = 16 \cdot f_{SAMPLE} = 2\text{MHz}$ , 12-bit mode, and digital inputs = GND or  $+V_{CC}$ , unless otherwise noted.

PARAMETER	CONDITIONS	ADS7846E			UNITS
		MIN	TYP	MAX	
<b>ANALOG INPUT</b> Full-Scale Input Span Absolute Input Range  Capacitance Leakage Current	Positive Input - Negative Input Positive Input Negative Input	0 -0.2 -0.2		$V_{REF}$ $+V_{CC} + 0.2$ $+0.2$	V V V pF $\mu\text{A}$
<b>SYSTEM PERFORMANCE</b> Resolution No Missing Codes Integral Linearity Error Offset Error Gain Error Noise Power Supply Rejection	External $V_{REF}$ Including Internal $V_{REF}$	11	12	$\pm 2$ $\pm 6$ $\pm 4$	Bits Bits LSB <sup>(1)</sup> LSB LSB $\mu\text{V}_{rms}$ dB
<b>SAMPLING DYNAMICS</b> Conversion Time Acquisition Time Throughput Rate Multiplexer Settling Time Aperture Delay Aperture Jitter Channel-to-Channel Isolation	$V_{IN} = 2.5\text{V}_{p-p}$ at 50kHz	3		12 125	CLK Cycles CLK Cycles kHz ns ns ps dB
<b>SWITCH DRIVERS</b> On-Resistance Y+, X+ Y-, X- Drive Current <sup>(2)</sup>	Duration 100ms		5 6	50	$\Omega$ $\Omega$ mA
<b>REFERENCE OUTPUT</b> Internal Reference Voltage Internal Reference Drift Input Impedance  Quiescent Current	Internal Reference ON Internal Reference OFF	2.45	2.50 15 250 1 500	2.55	V ppm/ $^\circ\text{C}$ $\Omega$ G $\Omega$ $\mu\text{A}$
<b>REFERENCE INPUT</b> Range Resistance	PD1 = 0, Internal Reference OFF	1.0	1	$V_{CC}$	V G $\Omega$
<b>BATTERY MONITOR</b> Input Voltage Range Input Impedance Sampling Battery Battery Monitor OFF Accuracy	$V_{REF} = 2.5\text{V}$ Internal Reference	0.5 -2 -3	10 1	6.0 +2 +3	V K $\Omega$ G $\Omega$ % %
<b>TEMPERATURE MEASUREMENT</b> Temperature Range Resolution  Accuracy	Differential Method <sup>(3)</sup> TEMP0 <sup>(4)</sup>  Differential Method <sup>(3)</sup> TEMP0 <sup>(4)</sup>	-40 $^\circ\text{C}$	1.6 0.3 $\pm 2$ $\pm 3$	+85	$^\circ\text{C}$ $^\circ\text{C}$ $^\circ\text{C}$ $^\circ\text{C}$ $^\circ\text{C}$
<b>DIGITAL INPUT/OUTPUT</b> Logic Family Logic Levels, Except PENIRQ $V_{IH}$ $V_{IL}$ $V_{OH}$ $V_{OL}$ PENIRQ $V_{OL}$ Data Format	$ I_H  \leq +5\mu\text{A}$ $ I_{IL}  \leq +5\mu\text{A}$ $I_{OH} = -250\mu\text{A}$ $I_{OL} = 250\mu\text{A}$  $T_A = 0^\circ\text{C}$ to $+85^\circ\text{C}$ , 50k $\Omega$ Pull-Up	$+V_{CC} \cdot 0.7$ -0.3 $+V_{CC} \cdot 0.8$	CMOS	$+V_{CC} + 0.3$ $+0.8$ 0.4 0.8	V V V V V

# SPECIFICATIONS (Cont.)

At  $T_A = -40^{\circ}\text{C}$  to  $+85^{\circ}\text{C}$ ,  $+V_{CC} = +2.7\text{V}$ ,  $V_{REF} = 2.5\text{V}$  internal voltage,  $f_{SAMPLE} = 125\text{kHz}$ ,  $f_{CLK} = 16 \cdot f_{SAMPLE} = 2\text{MHz}$ , 12-bit mode, and digital inputs = GND or  $+V_{CC}$ , unless otherwise noted.

PARAMETER	CONDITONS	ADS7846E			UNITS
		MIN	TYP	MAX	
<b>POWER SUPPLY REQUIREMENTS</b>					
$+V_{CC}^{(5)}$	Specified Performance	2.7		3.6	V
Quiescent Current	Operating Range	2.2		5.25	V
	Internal Reference OFF		280	650	$\mu\text{A}$
	Internal Reference ON		780		$\mu\text{A}$
	$f_{SAMPLE} = 12.5\text{kHz}$		220		$\mu\text{A}$
	Shut Down Mode with DCLK = DIN = $+V_{CC}$			3	$\mu\text{A}$
Power Dissipation	$+V_{CC} = +2.7\text{V}$			1.8	mW
<b>TEMPERATURE RANGE</b>					
Specified Performance		-40		+85	$^{\circ}\text{C}$

NOTES: (1) LSB means Least Significant Bit. With  $V_{REF}$  equal to  $+2.5\text{V}$ , one LSB is  $610\mu\text{V}$ . (2) Guaranteed by design, but not tested. Exceeding  $50\text{mA}$  source current may result in device degradation. (3) Difference between TEMPO and TEMP1 measurement. No calibration necessary. (4) Temperature drift is  $-2.1\text{mV}/^{\circ}\text{C}$ . (5) ADS7846 will operate down to  $2.2\text{V}$ .

## PIN CONFIGURATION

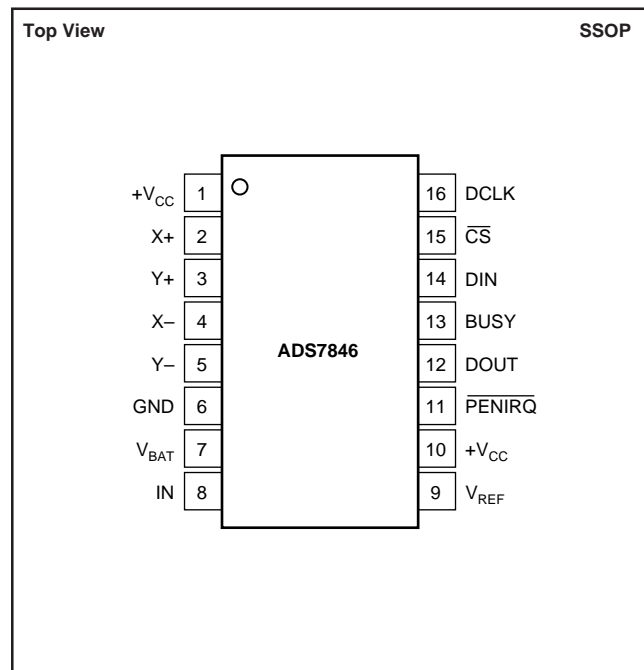

## PIN DESCRIPTION

PIN	NAME	DESCRIPTION
1	$+V_{CC}$	Power Supply
2	X+	X+ Position Input. ADC Input Channel 1.
3	Y+	Y+ Position Input. ADC Input Channel 2.
4	X-	X- Position Input
5	Y-	Y- Position Input
6	GND	Ground
7	$V_{BAT}$	Battery Monitor Input
8	IN	Auxiliary Input to ADC Input, Channel 4.
9	$V_{REF}$	Voltage Reference Input/Output
10	$+V_{CC}$	Power Supply
11	$\overline{\text{PENIRQ}}$	Pen Interrupt. Open anode output (requires $10\text{k}\Omega$ to $100\text{k}\Omega$ pull-up resistor externally).
12	DOUT	Serial Data Output. Data is shifted on the falling edge of DCLK. This output is high impedance when $\overline{\text{CS}}$ is HIGH.
13	BUSY	Busy Output. This output is high impedance when $\overline{\text{CS}}$ is HIGH.
14	DIN	Serial Data Input. If $\overline{\text{CS}}$ is LOW, data is latched on rising edge of DCLK.
15	$\overline{\text{CS}}$	Chip Select Input. Controls conversion timing and enables the serial input/output register. $\overline{\text{CS}}$ HIGH = power-down mode (ADC only).
16	DCLK	External Clock Input. This clock runs the SAR conversion process and synchronizes serial data I/O.

## ABSOLUTE MAXIMUM RATINGS<sup>(1)</sup>

+V <sub>CC</sub> to GND .....	-0.3V to +6V
Analog Inputs to GND .....	-0.3V to +V <sub>CC</sub> + 0.3V
Digital Inputs to GND .....	-0.3V to +V <sub>CC</sub> + 0.3V
Power Dissipation .....	250mW
Maximum Junction Temperature .....	+150°C
Operating Temperature Range .....	-40°C to +85°C
Storage Temperature Range .....	-65°C to +150°C
Lead Temperature (soldering, 10s) .....	+300°C

NOTE: (1) Stresses above those listed under "Absolute Maximum Ratings" may cause permanent damage to the device. Exposure to absolute maximum conditions for extended periods may affect device reliability.



## ELECTROSTATIC DISCHARGE SENSITIVITY

This integrated circuit can be damaged by ESD. Burr-Brown recommends that all integrated circuits be handled with appropriate precautions. Failure to observe proper handling and installation procedures can cause damage.

ESD damage can range from subtle performance degradation to complete device failure. Precision integrated circuits may be more susceptible to damage because very small parametric changes could cause the device not to meet its published specifications.

## PACKAGE/ORDERING INFORMATION

PRODUCT	MAXIMUM INTEGRAL LINEARITY ERROR (LSB)	PACKAGE	PACKAGE DRAWING NUMBER	SPECIFICATION TEMPERATURE RANGE	ORDERING NUMBER <sup>(1)</sup>	TRANSPORT MEDIA
ADS7846E "	±2 "	SSOP-16 "	322 "	-40°C to +85°C "	ADS7846E ADS7846E/2K5	Rails Tape and Reel
ADS7846N "	±2 "	TSSOP-16 "	363 "	-40°C to +85°C "	ADS7846N ADS7846N/2K5	Rails Tape and Reel

NOTE: (1) Models with a slash (/) are available only in Tape and Reel in the quantities indicated (e.g., /2K5 indicates 2500 devices per reel). Ordering 2500 pieces of "ADS7846E/2K5" will get a single 2500-piece Tape and Reel.

The information provided herein is believed to be reliable; however, BURR-BROWN assumes no responsibility for inaccuracies or omissions. BURR-BROWN assumes no responsibility for the use of this information, and all use of such information shall be entirely at the user's own risk. Prices and specifications are subject to change without notice. No patent rights or licenses to any of the circuits described herein are implied or granted to any third party. BURR-BROWN does not authorize or warrant any BURR-BROWN product for use in life support devices and/or systems.

# TYPICAL PERFORMANCE CURVES

At  $T_A = +25^\circ\text{C}$ ,  $+V_{CC} = +2.7\text{V}$ ,  $V_{REF} = \text{External } +2.5\text{V}$ ,  $f_{\text{SAMPLE}} = 125\text{kHz}$ , and  $f_{\text{CLK}} = 16 \cdot f_{\text{SAMPLE}} = 2\text{MHz}$ , unless otherwise noted.

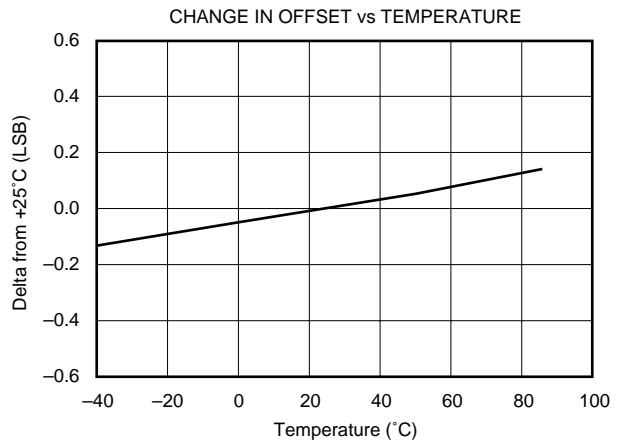
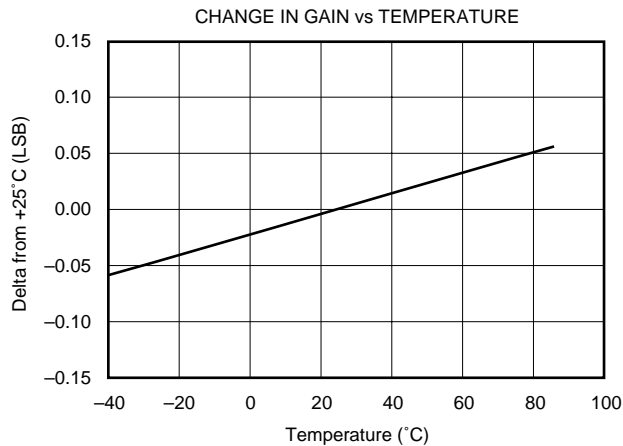
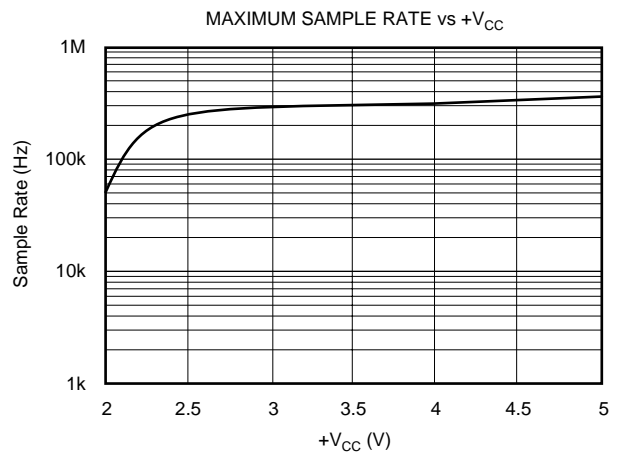
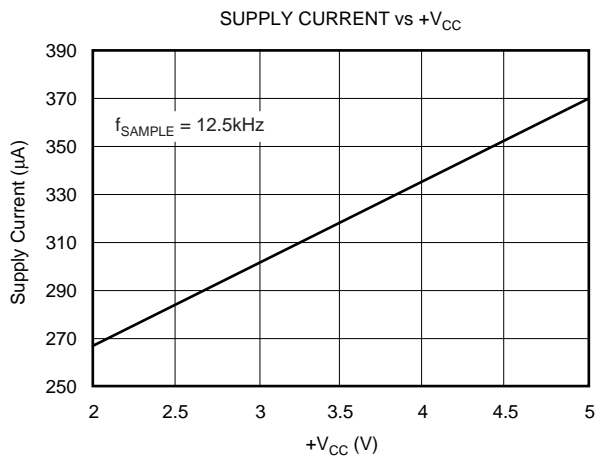
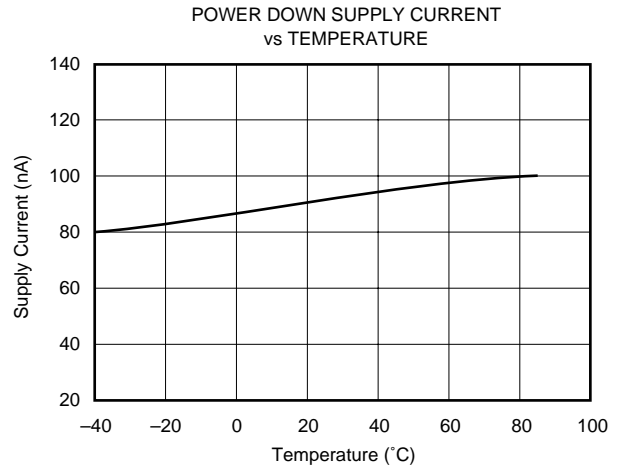
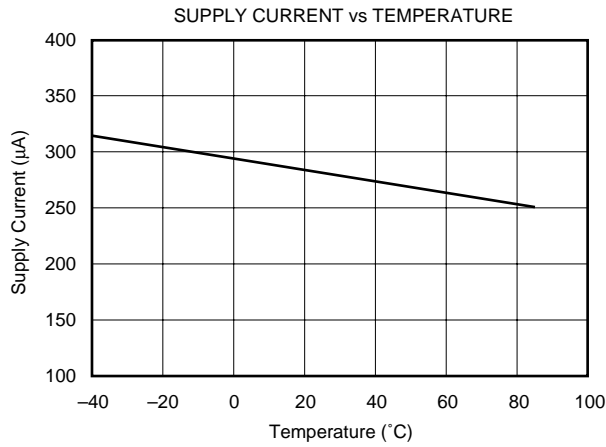

# TYPICAL PERFORMANCE CURVES (Cont.)

At  $T_A = +25^\circ\text{C}$ ,  $+V_{CC} = +2.7\text{V}$ ,  $V_{REF} = \text{External } +2.5\text{V}$ ,  $f_{\text{SAMPLE}} = 125\text{kHz}$ , and  $f_{\text{CLK}} = 16 \cdot f_{\text{SAMPLE}} = 2\text{MHz}$ , unless otherwise noted.

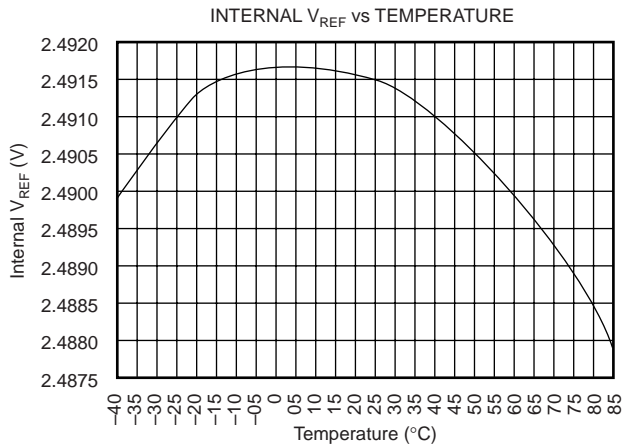
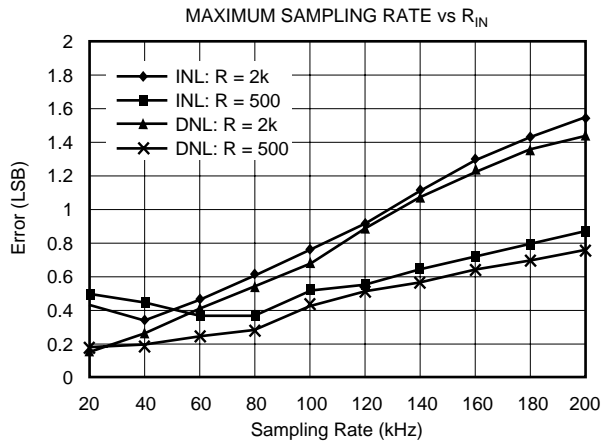
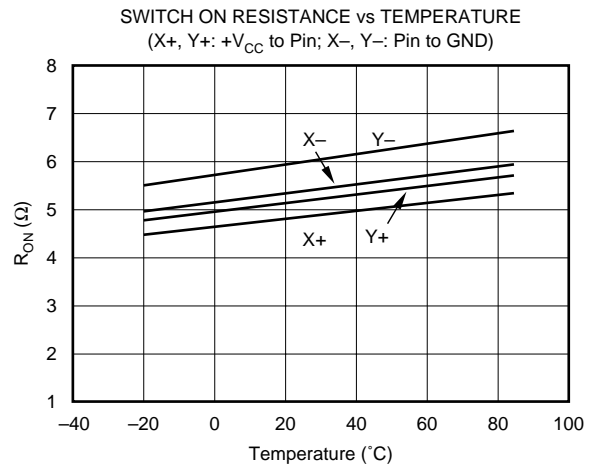
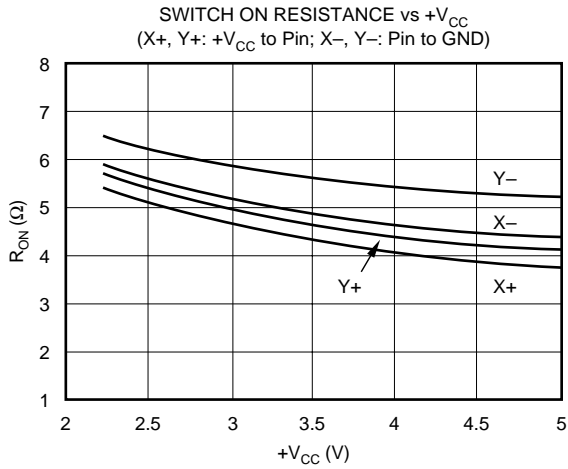
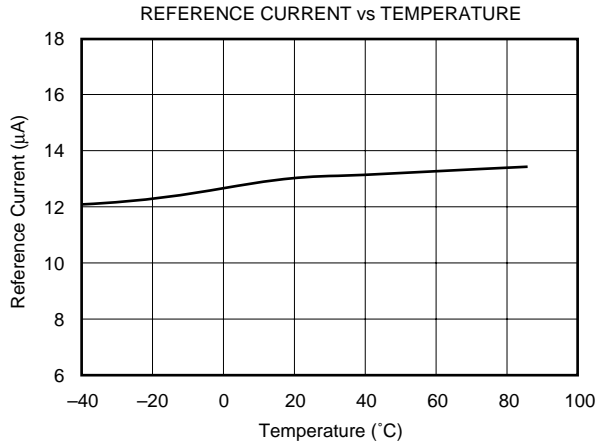
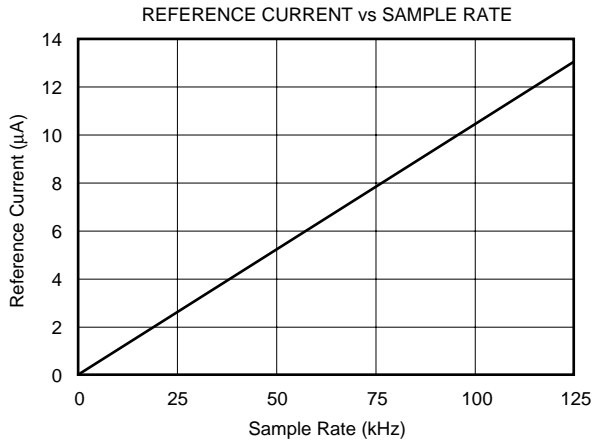

# TYPICAL PERFORMANCE CURVES (Cont.)

At  $T_A = +25^\circ\text{C}$ ,  $+V_{CC} = +2.7\text{V}$ ,  $V_{REF} = \text{External } +2.5\text{V}$ ,  $f_{\text{SAMPLE}} = 125\text{kHz}$ , and  $f_{\text{CLK}} = 16 \cdot f_{\text{SAMPLE}} = 2\text{MHz}$ , unless otherwise noted.

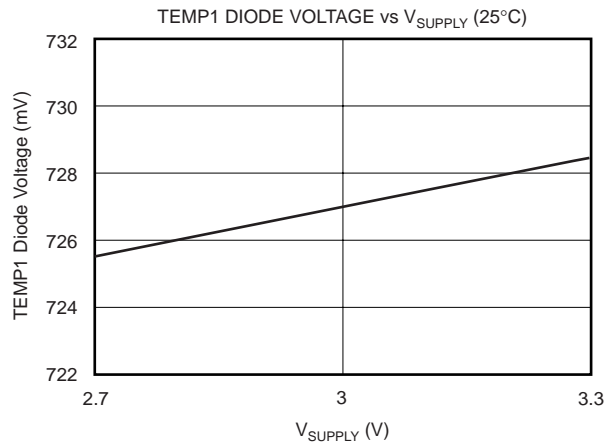
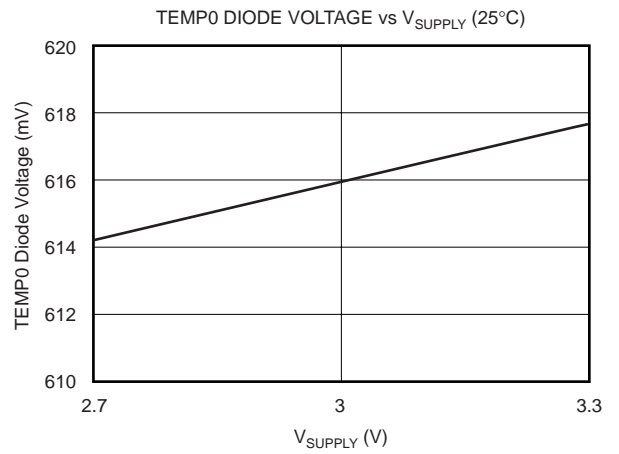
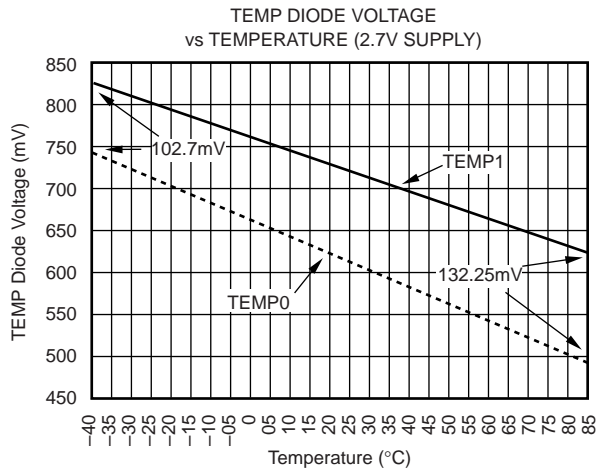
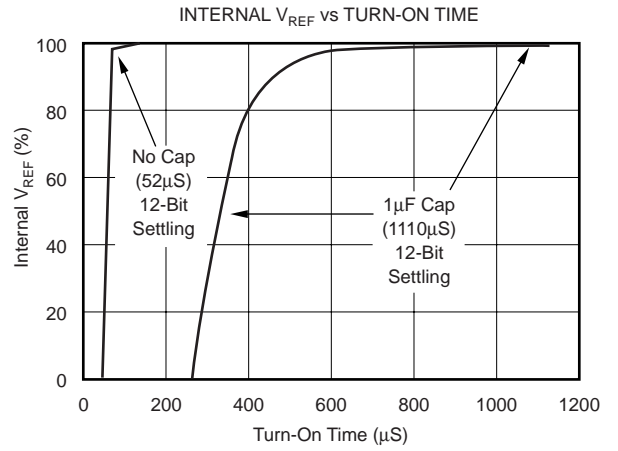
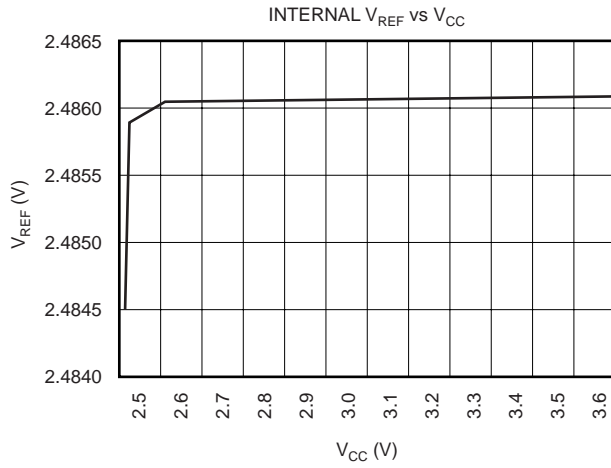

# THEORY OF OPERATION

The ADS7846 is a classic Successive Approximation Register (SAR) Analog-to-Digital Converter (ADC). The architecture is based on capacitive redistribution which inherently includes a sample/hold function. The converter is fabricated on a 0.6µs CMOS process.

The basic operation of the ADS7846 is shown in Figure 1. The device features an internal 2.5V reference and an external clock. Operation is maintained from a single supply of 2.7V to 5.25V. The internal reference can be overdriven with an external, low impedance source between 1V and +V<sub>CC</sub>. The value of the reference voltage directly sets the input range of the converter.

The analog input (X, Y, and Z panel coordinates, battery voltage, and chip temperature) to the converter is provided via a multiplexer. A unique configuration of low on-resistance switches allows an unselected ADC input channel to provide power and an accompanying pin to provide ground for an external device. By maintaining a differential input to the converter and a differential reference architecture, it is

possible to negate the switch's on-resistance error (should this be a source of error for the particular measurement).

## ANALOG INPUT

Figure 2 shows a block diagram of the input multiplexer on the ADS7846, the differential input of the ADC, and the converter's differential reference. Table I and Table II show the relationship between the A2, A1, A0, and SER/DFR control bits and the configuration of the ADS7846. The control bits are provided serially via the DIN pin—see the Digital Interface section of this data sheet for more details.

When the converter enters the hold mode, the voltage difference between the +IN and -IN inputs (see Figure 2) is captured on the internal capacitor array. The input current on the analog inputs depends on the conversion rate of the device. During the sample period, the source must charge the internal sampling capacitor (typically 25pF). After the capacitor has been fully charged, there is no further input current. The rate of charge transfer from the analog source to the converter is a function of conversion rate.

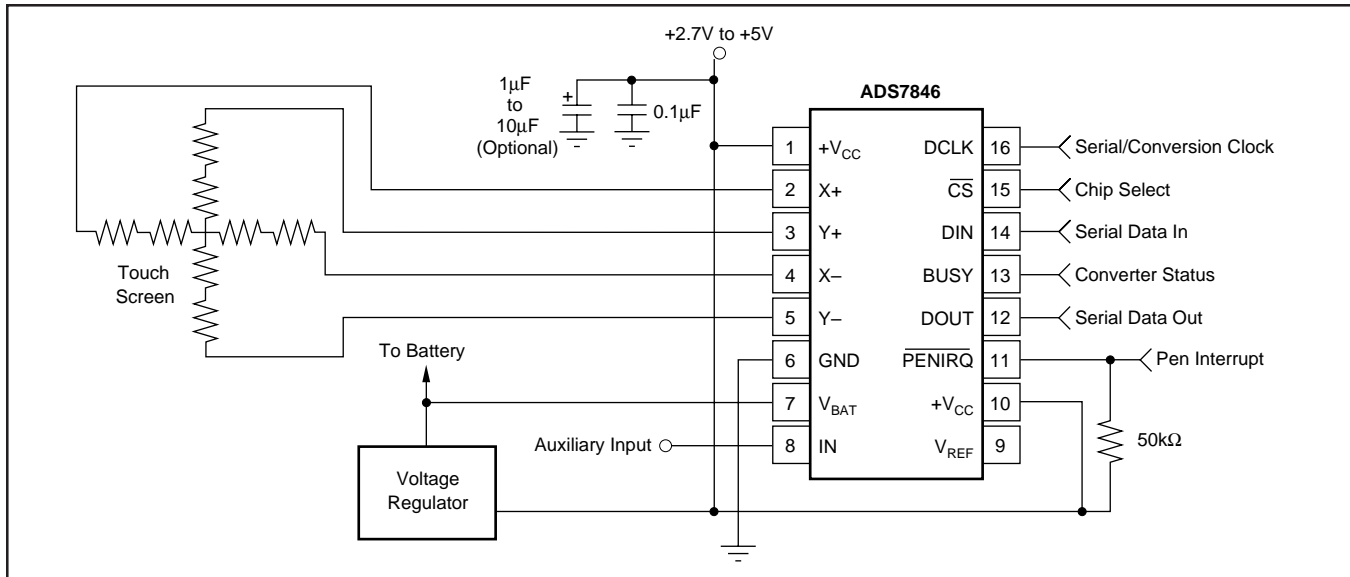

FIGURE 1. Basic Operation of the ADS7846.

A2	A1	A0	V <sub>BAT</sub>	AUX <sub>IN</sub>	TEMP	Y-	X+	Y+	Y-POSITION	X-POSITION	Z <sub>1</sub> -POSITION	Z <sub>2</sub> -POSITION	X-DRIVERS	Y-DRIVERS
0	0	0			+IN (TEMP 0)								OFF	OFF
0	0	1	+IN				+IN		Measure				OFF	ON
0	1	0												
0	1	1					+IN		Measure		Measure	Measure	X-, ON	Y+, ON
1	0	0				+IN								
1	0	1						+IN	Measure		Measure	Measure	ON	OFF
1	1	0	+IN											
1	1	1				+IN (TEMP 1)								OFF

TABLE I. Input Configuration (DIN), Single-Ended Reference Mode (SER/DFR HIGH).

A2	A1	A0	+REF	-REF	Y-	X+	Y+	Y-POSITION	X-POSITION	Z <sub>1</sub> -POSITION	Z <sub>2</sub> -POSITION	DRIVERS ON
0	0	1	Y+	Y-		+IN		Measure		Measure	Measure	Y+, Y-
0	1	1	Y+	X-		+IN						
1	0	0	Y+	X-	+IN			Measure		Measure	Measure	Y+, X-
1	0	1	X+	X-			+IN					

TABLE II. Input Configuration (DIN), Differential Reference Mode (SER/DFR LOW).



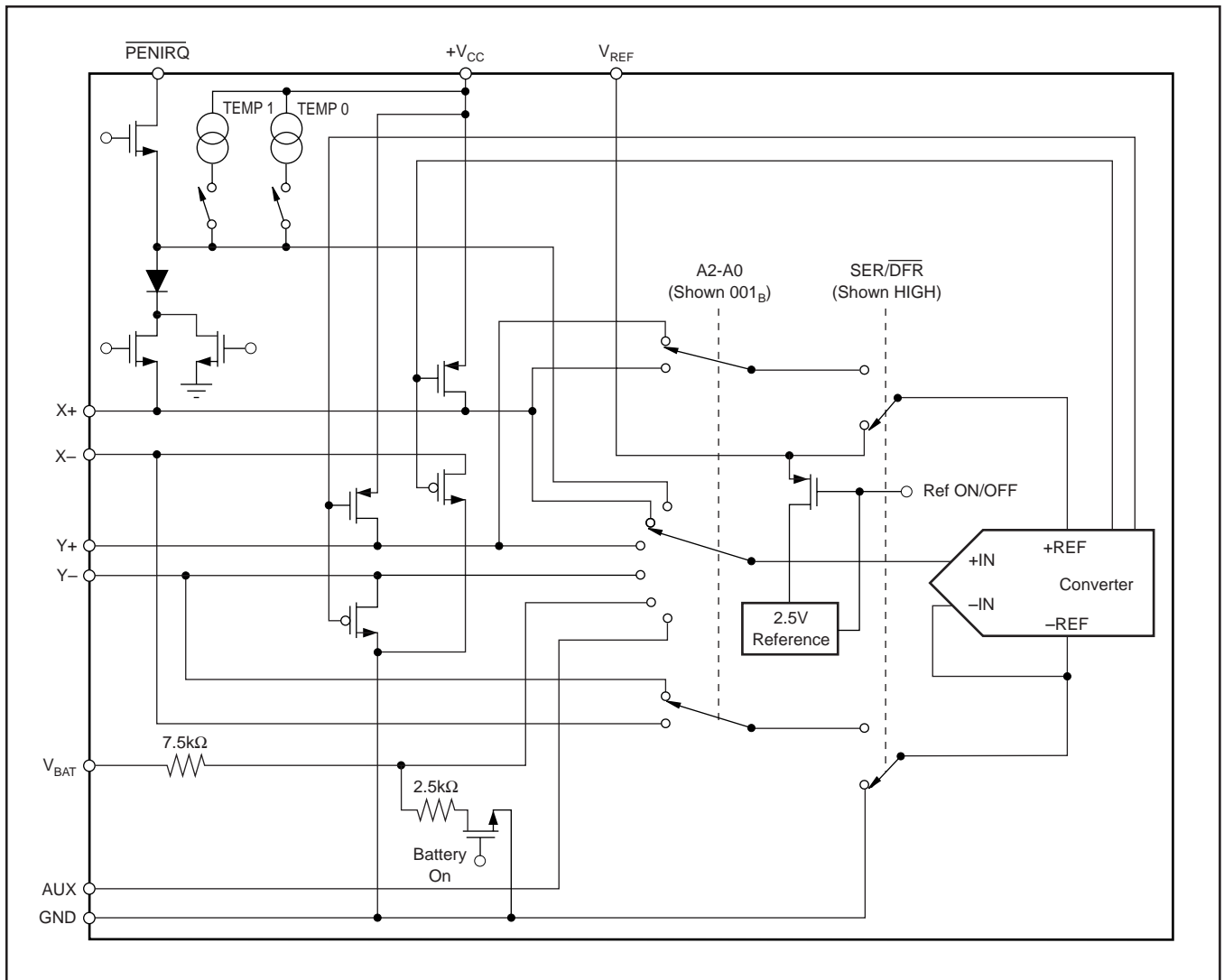

FIGURE 2. Simplified Diagram of Analog Input.

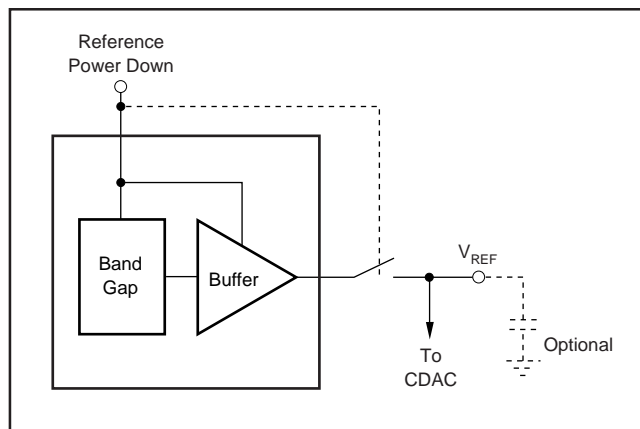

FIGURE 3. Simplified Diagram of the Internal Reference.

### INTERNAL REFERENCE

The ADS7846 has an internal 2.5V voltage reference that can be turned ON or OFF with the power-down address, PD1 = 1 (see Table V and Figure 3). Typically, the internal reference voltage is only used in the single-ended mode for battery monitoring, temperature measurement, and for uti-

lizing the auxiliary input. Optimal touch-screen performance is achieved when utilizing the differential mode. The internal reference voltage of the ADS7846 must be commanded to be OFF to maintain compatibility with the ADS7843. Therefore, after power-up, a write of PD1 = 0 is required to insure the reference is OFF. See Typical Performance Curves for power-up time of the reference from power-down.

### REFERENCE INPUT

The voltage difference between +REF and -REF (see Figure 2) sets the analog input range. The ADS7846 will operate with a reference in the range of 1V to +V<sub>CC</sub>. There are several critical items concerning the reference input and its wide voltage range. As the reference voltage is reduced, the analog voltage weight of each digital output code is also reduced. This is often referred to as the LSB (Least Significant Bit) size and is equal to the reference voltage divided by 4096. Any offset or gain error inherent in the ADC will appear to increase, in terms of LSB size, as the reference voltage is reduced. For example, if the offset of a given converter is 2 LSBs with a 2.5V reference, it will typically be 5 LSBs with a 1V reference. In each case, the actual offset of the device

is the same, 1.22mV. With a lower reference voltage, more care must be taken to provide a clean layout including adequate bypassing, a clean (low noise, low ripple) power supply, a low-noise reference (if an external reference is used), and a low-noise input signal.

The voltage into the  $V_{REF}$  input is buffered and directly drives the Capacitor Digital-to-Analog Converter (CDAC) portion of the ADS7846. Therefore, the input current is very low (typically  $< 1\text{nA}$ ).

There is also a critical item regarding the reference when making measurements where the switch drivers are ON. For this discussion, it's useful to consider the basic operation of the ADS7846 as shown in Figure 1. This particular application shows the device being used to digitize a resistive touch screen. A measurement of the current Y position of the pointing device is made by connecting the X+ input to the ADC, turning on the Y+ and Y- drivers, and digitizing the voltage on X+ (see Figure 4 for a block diagram). For this measurement, the resistance in the X+ lead does not affect the conversion (it does affect the settling time, but the resistance is usually small enough that this is not a concern). However, since the resistance between Y+ and Y- is fairly low, the on-resistance of the Y drivers does make a small difference. Under the situation outlined so far, it would not be possible to achieve a zero volt input or a full-scale input regardless of where the pointing device is on the touch screen because some voltage is lost across the internal switches. In addition, the internal switch resistance is unlikely to track the resistance of the touch screen, providing an additional source of error.

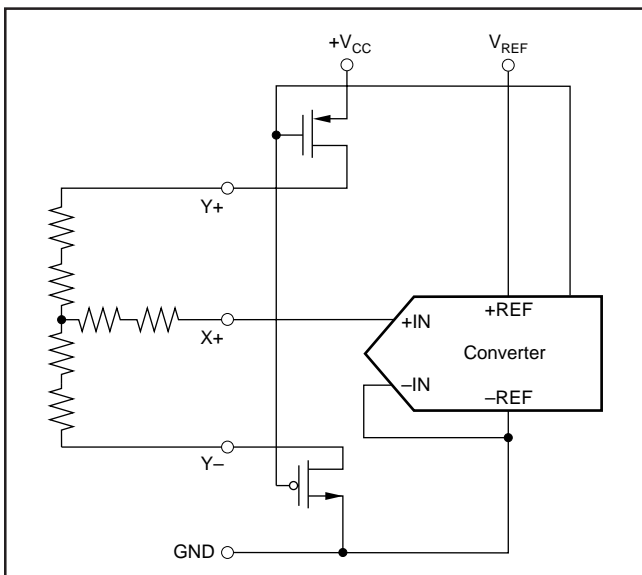

FIGURE 4. Simplified Diagram of Single-Ended Reference (SER/DFR HIGH, Y Switches Enabled, X+ is Analog Input).

This situation can be remedied as shown in Figure 5. By setting the SER/DFR bit LOW, the +REF and -REF inputs are connected directly to Y+ and Y-. This makes the analog-to-digital conversion ratiometric. The result of the

conversion is always a percentage of the external resistance, regardless of how it changes in relation to the on-resistance of the internal switches. Note that there is an important consideration regarding power dissipation when using the ratiometric mode of operation (see the Power Dissipation section for more details).

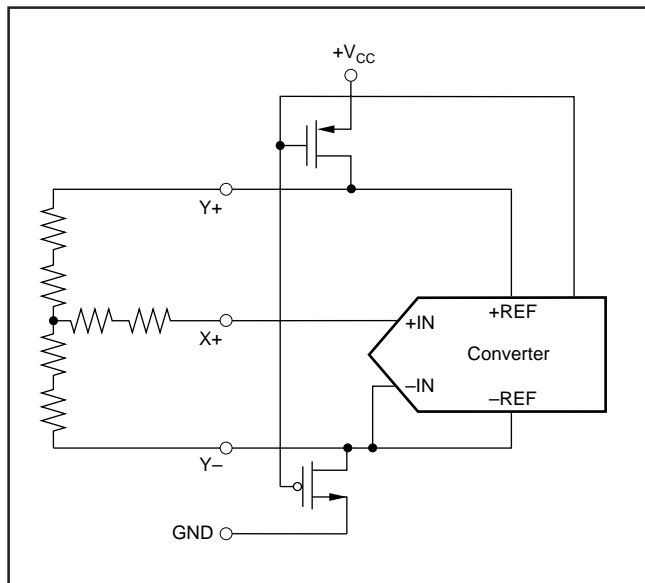

FIGURE 5. Simplified Diagram of Differential Reference (SER/DFR LOW, Y Switches Enabled, X+ is Analog Input).

As a final note about the differential reference mode, it must be used with +V<sub>CC</sub> as the source of the +REF voltage and cannot be used with V<sub>REF</sub>. It is possible to use a high precision reference on V<sub>REF</sub> and single-ended reference mode for measurements which do not need to be ratiometric. In some cases it could be possible to power the converter directly from a precision reference. Most references can provide enough power for the ADS7846, but they might not be able to supply enough current for the external load (such as a resistive touch screen).

## TOUCH-SCREEN SETTling

In some application, external capacitors may be required across the touch-screen for filtering noise picked up by the touch-screen, i.e. noise generated by the LCD panel or backlight circuitry. The value of these capacitors will provide a low-pass filter to reduce the noise, but will cause a settling time requirement when the panel is touched. The settling time will typically show up as a Gain Error. There are several methods for minimizing or eliminating this issue. The problem is the input and/or reference has not settled to its final steady-state value prior to the ADC sampling the input(s) and provides the digital output. Additionally, the reference voltage may still be changing during the measurement cycle. What are the options? Option 1 is to stop or slow down the ADS7846 DCLK for the required touch-screen settling time. This will allow the input and reference to have stable values for the 'Acquire' period (3 clock cycles of the

ADS7846; see Figure 9). This will work for both the single-ended and the differential modes. Option 2 is to operate the ADS7846 in the differential mode only for the touch-screen, and command the ADS7846 to remain ON (touch-screen drivers ON) and not go into power-down (PD0 = PD1 = 1). Several conversions will be required depending on the settling time required and ADS7846 data rate. Once the required number of conversions have been made, the processor will command the ADS7846 into its power-down state on the last measurement. This process would be required for X-position, Y-position, and Z-position. Option 3 is to operate in the 15-Clock per Conversion mode which overlaps ADCs and maintains the touch-screen drivers ON until it is commanded to stop by the processor.

## TEMPERATURE MEASUREMENT

In some applications, such as battery recharging, a measurement of ambient temperature is required. The temperature measurement technique used in the ADS7846 relies on the characteristics of a semiconductor junction operation at a fixed current level. The forward diode voltage ( $V_{BE}$ ) has a well-defined characteristic versus temperature. The ambient temperature can be predicted in applications by knowing the 25°C value of the  $V_{BE}$  voltage and then monitoring the delta of that voltage as the temperature changes. The ADS7846 offers two modes of operation. The first mode requires calibration at a known temperature, but only requires a single reading to predict the ambient temperature. The PENIRQ diode is used (turned ON) during this measurement cycle and the voltage across the diode is connected through the MUX for digitizing the forward bias voltage by the ADC with an address of A2 = 0, A1 = 0, and A0 = 0 (see Table I and Figure 6 for details). This voltage is typically 600mV at +25°C, with a 20µA current through it. The absolute value of this diode voltage can vary a few millivolts, however, the TC of this voltage is very consistent at -2.1mV/°C. During the final test of the end product, the diode voltage would be stored at a known room temperature, in memory, for calibration purposes by the user. The result is an equivalent temperature measurement resolution of 0.3°C/LSB.

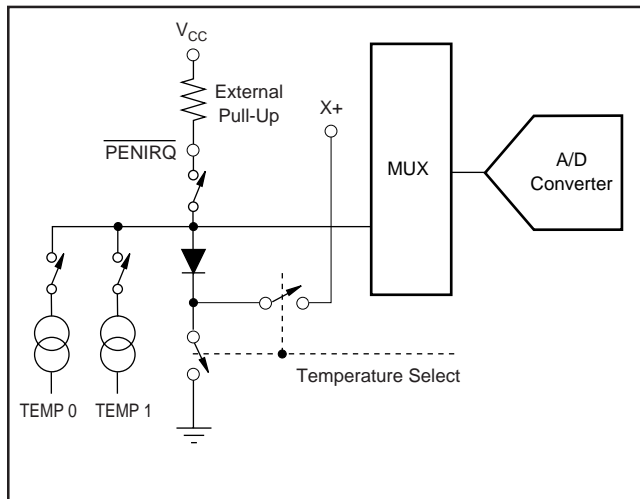

FIGURE 6. Functional Block Diagram of Temperature Measurement Mode.

The second mode does not require a test temperature calibration, but uses a two-measurement method to eliminate the need for absolute temperature calibration and for achieving 2°C/LSB accuracy. This mode requires a second conversion with an address of A2 = 1, A1 = 1, and A0 = 1, with an 82 times larger current. The voltage difference between the first and second conversion using 82 times the bias current will be represented by  $kT/q \cdot \ln(N)$ , where N is the current ratio = 82, k = Boltzmann's constant ( $1.38054 \cdot 10^{-23}$  electrons volts/degrees Kelvin), q = the electron charge ( $1.602189 \cdot 10^{-19}$  °C), and T = the temperature in degrees Kelvin. This method can provide much improved absolute temperature measurement, but less resolution of 2°C/LSB. The resultant equation for solving for °K is:

$$^{\circ}\text{K} = q \cdot \Delta V / (k \cdot \ln(N)) \quad (1)$$

where,

$$\Delta V = V(I_{82}) - V(I_1) \text{ (in mV)}$$

$$\therefore ^{\circ}\text{K} = 2.68 \Delta V \text{ } ^{\circ}\text{K/mV}$$

$$^{\circ}\text{C} = 2.63 \cdot \Delta V(\text{mV}) - 273^{\circ}\text{K}$$

NOTE: The bias current for each diode temperature measurement is only turned ON for 3 clock cycles (during the acquisition mode) and, therefore, does not add any noticeable increase in power, especially if the temperature measurement only occurs occasionally.

## BATTERY MEASUREMENT

An added feature of the ADS7846 is the ability to monitor the battery voltage on the other side of the voltage regulator (DC/DC converter), as shown in Figure 7. The battery voltage can vary from 0.5V to 6V, while maintaining the voltage to the ADS7846 at 2.7V, 3.3V, etc. The input voltage ( $V_{BAT}$ ) is divided down by 4 so that a 6.0V battery voltage is represented as 1.5V to the ADC. This simplifies

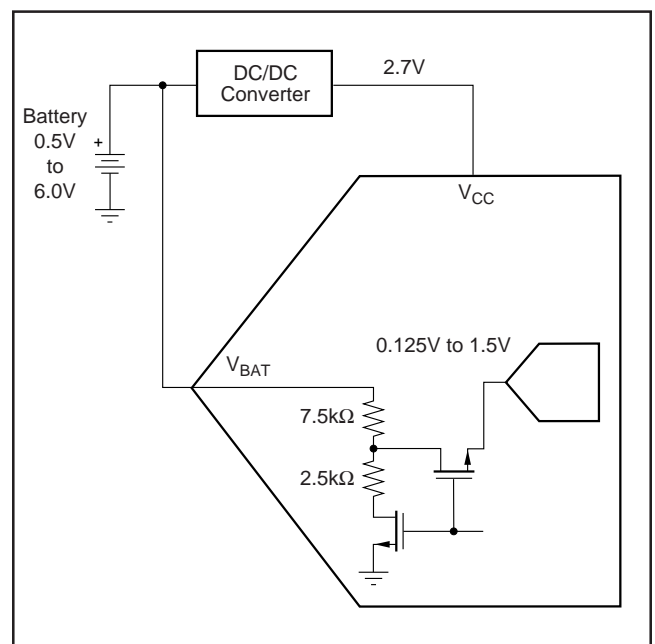

FIGURE 7. Battery Measurement Functional Block Diagram.

the multiplexer and control logic. In order to minimize the power consumption, the divider is only ON during the sampling of DIN to A2 = 0, A1 = 1, and A0 = 0. Tables I and II show the relationship between the control bits and configuration of the ADS7846.

### PRESSURE MEASUREMENT

Measuring touch pressure can also be done with the ADS7846. To determine pen or finger touch, the pressure of the “touch” needs to be determined. Generally, it is not necessary to have very high performance for this test, therefore, the 8-bit resolution mode is recommended (however, calculations will be shown with the 12-bit resolution mode). There are several different ways of performing this measurement. The ADS7846 supports two methods. The first method requires knowing the X-plate resistance, measurement of the X-Position, and two additional cross panel measurements (Z<sub>2</sub> and Z<sub>1</sub>) of the touch screen (see Figure 8). Using Equation 2 will calculate the touch resistance:

$$R_{TOUCH} = R_{X - plate} \cdot \frac{X - Position}{4096} \left( \frac{Z_2}{Z_1} - 1 \right) \quad (2)$$

The second method requires knowing both the X-plate and Y-plate resistance, measurement of X-Position and Y-Position, and Z<sub>1</sub>. Using Equation 3 will also calculate the touch resistance:

$$R_{TOUCH} = \frac{R_{X - plate} \cdot X - Position}{4096} \left( \frac{4096}{Z_1} - 1 \right) - R_{Y - plate} \cdot \frac{Y Position}{4096} \quad (3)$$

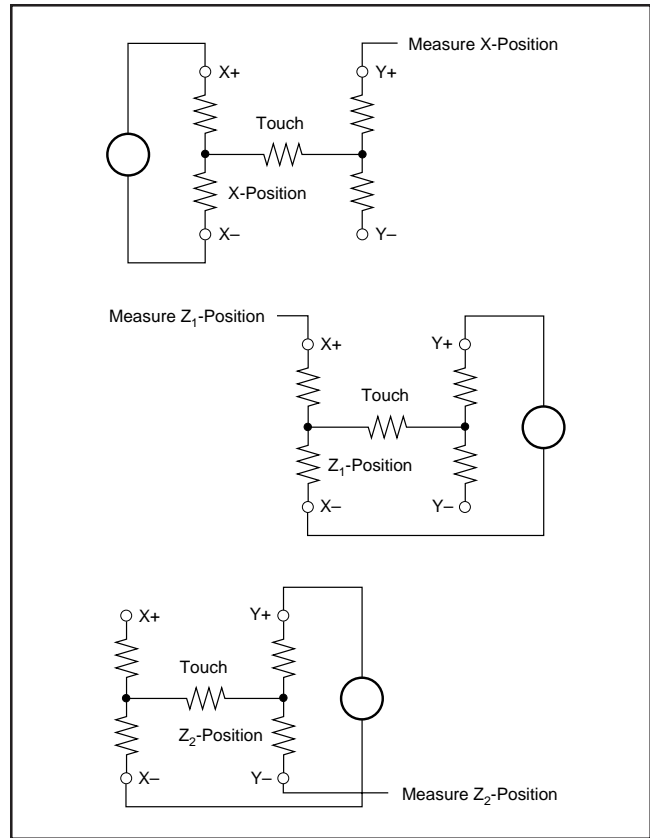

FIGURE 8. Pressure Measurement Block Diagrams.

### DIGITAL INTERFACE

Figure 9 shows the typical operation of the ADS7846’s digital interface. This diagram assumes that the source of the digital signals is a microcontroller or digital signal processor with a basic serial interface. Each communication between the processor and the converter, such as SPI/SSI or micro-wire synchro-

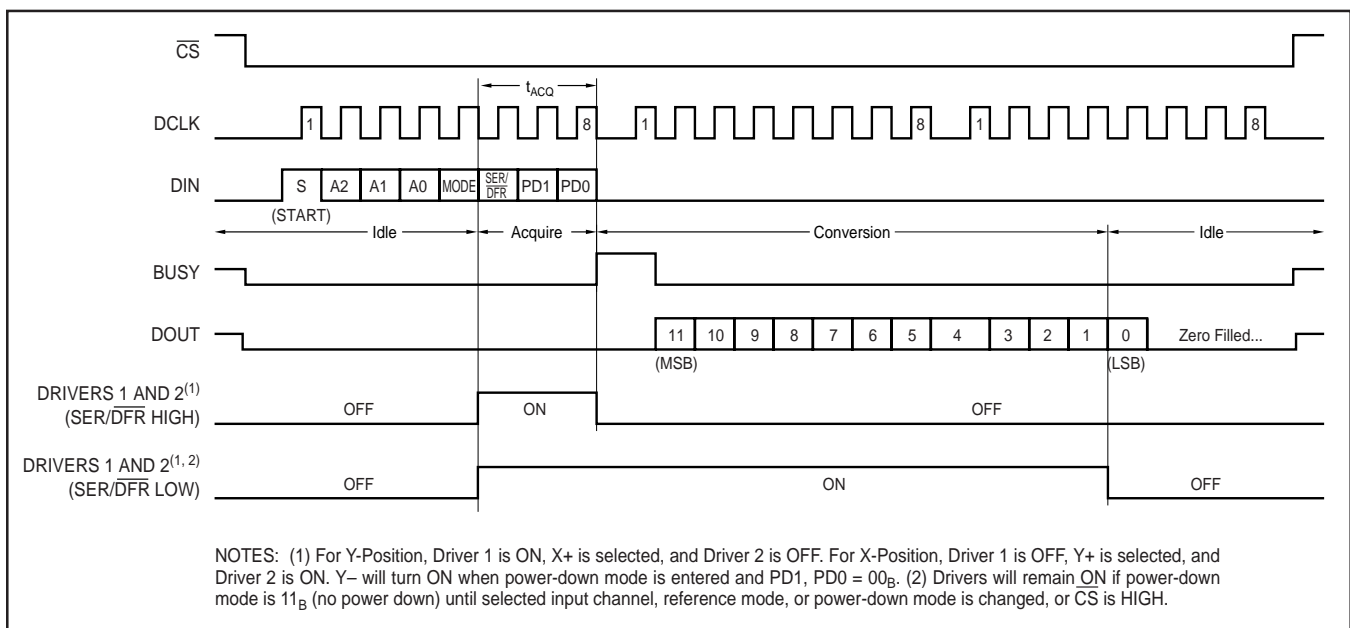

FIGURE 9. Conversion Timing, 24-Clocks per Conversion, 8-bit Bus Interface. No DCLK delay required with dedicated serial port.

nous serial interface, consists of eight clock cycles. One complete conversion can be accomplished with three serial communications, for a total of 24 clock cycles on the DCLK input.

The first eight clock cycles are used to provide the control byte via the DIN pin. When the converter has enough information about the following conversion to set the input multiplexer, switches, and reference inputs appropriately, the converter enters the acquisition (sample) mode and, if needed, the internal switches are turned on. After three more clock cycles, the control byte is complete and the converter enters the conversion mode. At this point, the input sample/hold goes into the hold mode and the internal switches may turn OFF (in single-ended mode, battery-monitor mode, or temperature-measurement mode). The next twelve clock cycles accomplish the actual analog-to-digital conversion. If the conversion is ratiometric ( $\overline{\text{SER/DFR}}$  LOW), the internal switches are on during the conversion. A thirteenth clock cycle is needed for the last bit of the conversion result. Three more clock cycles are needed to complete the last byte (DOUT will be LOW). These will be ignored by the converter.

### Control Byte

The control byte (on DIN), shown in Table III, provides the start conversion, addressing, ADC resolution, configuration, and power down of the ADS7846. Figure 9 and Tables III and IV give detailed information regarding the order and description of these control bits within the control byte.

**Initiate START**—The first bit, the “S” bit, must always be HIGH and initiates the start of the control byte. The ADS7846 will ignore inputs on the DIN pin until the start bit is detected.

Bit 7 (MSB)	Bit 6	Bit 5	Bit 4	Bit 3	Bit 2	Bit 1	Bit 0 (LSB)
S	A2	A1	A0	MODE	$\overline{\text{SER/DFR}}$	PD1	PD0

TABLE III. Order of the Control Bits in the Control Byte.

BIT	NAME	DESCRIPTION
7	S	Start Bit. Control byte starts with first HIGH bit on DIN. A new control byte can start every 15th clock cycle in 12-bit conversion mode or every 11th clock cycle in 8-bit conversion mode.
6 - 4	A2 - A0	Channel Select Bits. Along with the $\overline{\text{SER/DFR}}$ bit, these bits control the setting of the multiplexer input, switches, and reference inputs, as detailed in Tables I and II.
3	MODE	12-Bit/8-Bit Conversion Select Bit. This bit controls the number of bits for the following conversion: 12-bits (LOW) or 8-bits (HIGH).
2	$\overline{\text{SER/DFR}}$	Single-Ended/Differential Reference Select Bit. Along with bits A2 - A0, this bit controls the setting of the multiplexer input, switches, and reference inputs, as detailed in Tables I and II.
1 - 0	PD1 - PD0	Power-Down Mode Select Bits. See Table V for details.

TABLE IV. Descriptions of the Control Bits within the Control Byte.

**Addressing**—The next three bits (A2, A1, and A0) select the active input channel(s) of the input multiplexer (see Tables I, II, and Figure 2), touch-screen drivers, and the reference inputs.

**MODE**—The mode bit sets the resolution of the ADC. With this bit LOW, the following conversion will be 12 bits of resolution. With this bit HIGH, the following conversion will be 8 bits of resolution.

**$\overline{\text{SER/DFR}}$** —The  $\overline{\text{SER/DFR}}$  bit controls the reference mode, either single-ended (HIGH) or differential (LOW). The differential mode is also referred to as the ratiometric conversion mode. The differential mode is preferred for X-Position, Y-Position, and Pressure-Touch measurements for optimum performance. The reference is derived from the voltage at the switch drivers, which is almost the same as the voltage to the touch screen. In this case a reference voltage is not needed, as the reference voltage to the ADC is the voltage across the touch screen. In the single-ended mode, the converter’s reference voltage is always the difference between the  $V_{\text{REF}}$  and GND pins. See Tables I and II, and Figures 2 through 4 for further information.

If X-Position, Y-Position, and Pressure Touch are measured in the single-ended mode, an external reference voltage is needed. The ADS7846 should also be powered from the external reference. Caution should be observed when utilizing the single-ended mode such that the input voltage to the ADC does not exceed the internal reference voltage, especially if the supply voltage is greater than 2.7V.

NOTE: The differential mode can only be used for X-Position, Y-Position and Pressure Touch measurements. All other measurements require the single-ended mode.

**PD0 and PD1**—Table V describes the power down and the internal reference voltage configurations. The internal reference voltage can be turned ON or OFF independently of the ADC. This can allow extra time for the internal reference voltage to settle to its final value prior to making a conversion. Make sure to also allow this extra wake-up time if the internal reference was powered down. The ADC requires no wake-up time and can be instantaneously used. Also note that the status of the internal reference power down is latched into the part (internally) with BUSY going HIGH. Therefore, in order to turn the reference OFF, an additional write to the ADS7846 is required after the channel has been converted.

PD1	PD0	PENIRQ	DESCRIPTION
0	0	Enabled	Power-Down Between Conversions. When each conversion is finished, the converter enters a low power mode. At the start of the next conversion, the device instantly powers up to full power. There is no need for additional delays to assure full operation and the very first conversion is valid. The Y- switch is ON while in power down.
0	1	Enabled	Reference is OFF and ADC is ON.
1	0	Enabled	Reference is ON and ADC is OFF.
1	1	Disabled	Device is always powered. Reference is ON and ADC is ON.

TABLE V. Power-Down Selection.

## 16-Clocks per Conversion

The control bits for conversion 'n+1' can be overlapped with conversion 'n' to allow for a conversion every 16 clock cycles, as shown in Figure 10. This figure also shows possible serial communication occurring with other serial peripherals between each byte transfer between the processor and the converter. This is possible provided that each conversion completes within 1.6ms of starting. Otherwise, the signal that has been captured on the input sample/hold may droop enough to affect the conversion result. Note that the ADS7846 is fully powered while other serial communications are taking place during a conversion.

### Digital Timing

Figure 11 and Table VI provide detailed timing for the digital interface of the ADS7846.

SYMBOL	DESCRIPTION	MIN	TYP	MAX	UNITS
$t_{ACQ}$	Acquisition Time	1.5			$\mu$ s
$t_{DS}$	DIN Valid Prior to DCLK Rising	100			ns
$t_{DH}$	DIN Hold After DCLK HIGH	10			ns
$t_{DO}$	DCLK Falling to DOUT Valid			200	ns
$t_{DV}$	$\overline{CS}$ Falling to DOUT Enabled			200	ns
$t_{TR}$	$\overline{CS}$ Rising to DOUT Disabled			200	ns
$t_{CSS}$	$\overline{CS}$ Falling to First DCLK Rising	100			ns
$t_{CSH}$	$\overline{CS}$ Rising to DCLK Ignored	0			ns
$t_{CH}$	DCLK HIGH	200			ns
$t_{CL}$	DCLK LOW	200			ns
$t_{BD}$	DCLK Falling to BUSY Rising			200	ns
$t_{BDV}$	$\overline{CS}$ Falling to BUSY Enabled			200	ns
$t_{BTR}$	$\overline{CS}$ Rising to BUSY Disabled			200	ns

TABLE VI. Timing Specifications ( $+V_{CC} = +2.7V$  and Above,  $T_A = -40^\circ C$  to  $+85^\circ C$ ,  $C_{LOAD} = 50pF$ ).

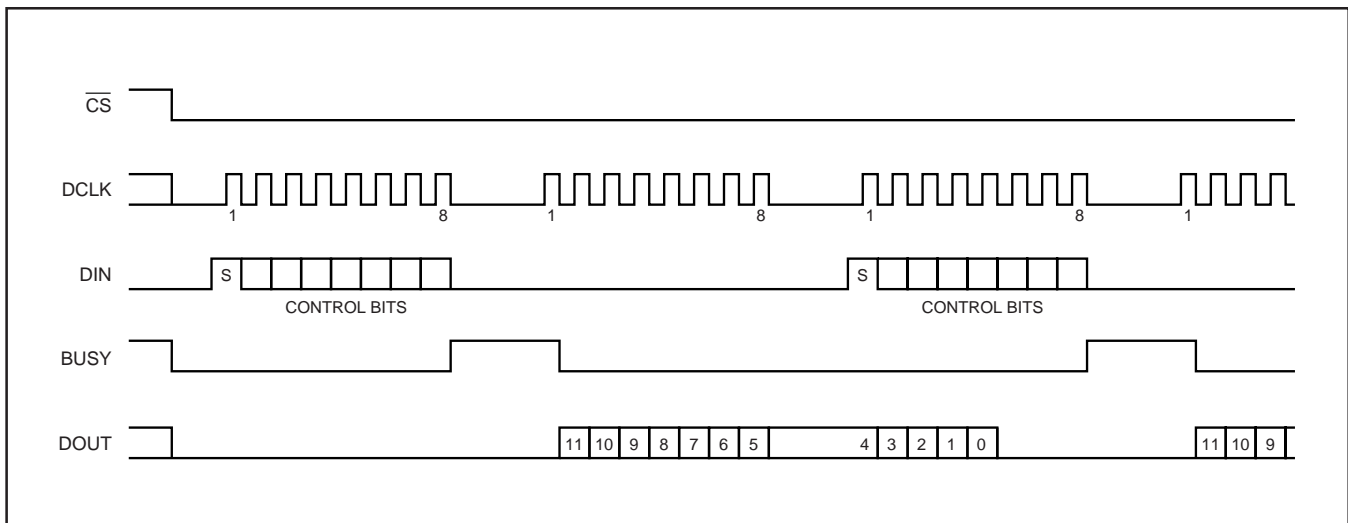

FIGURE 10. Conversion Timing, 16-Clocks per Conversion, 8-bit Bus Interface. No DCLK delay required with dedicated serial port.

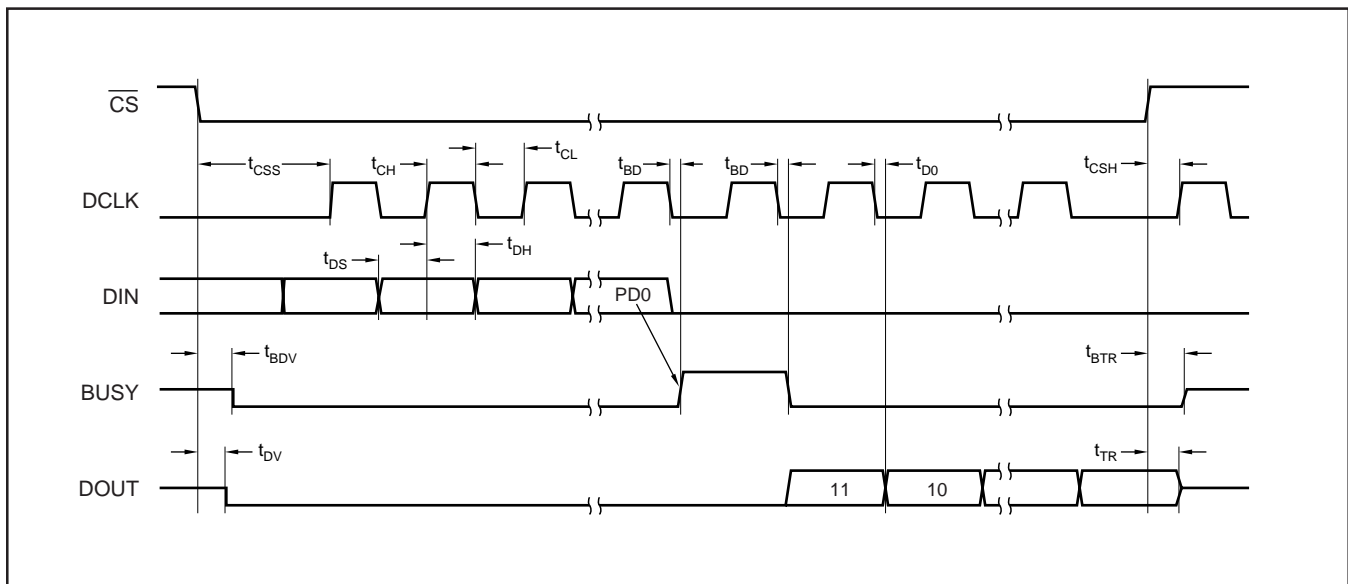

FIGURE 11. Detailed Timing Diagram.

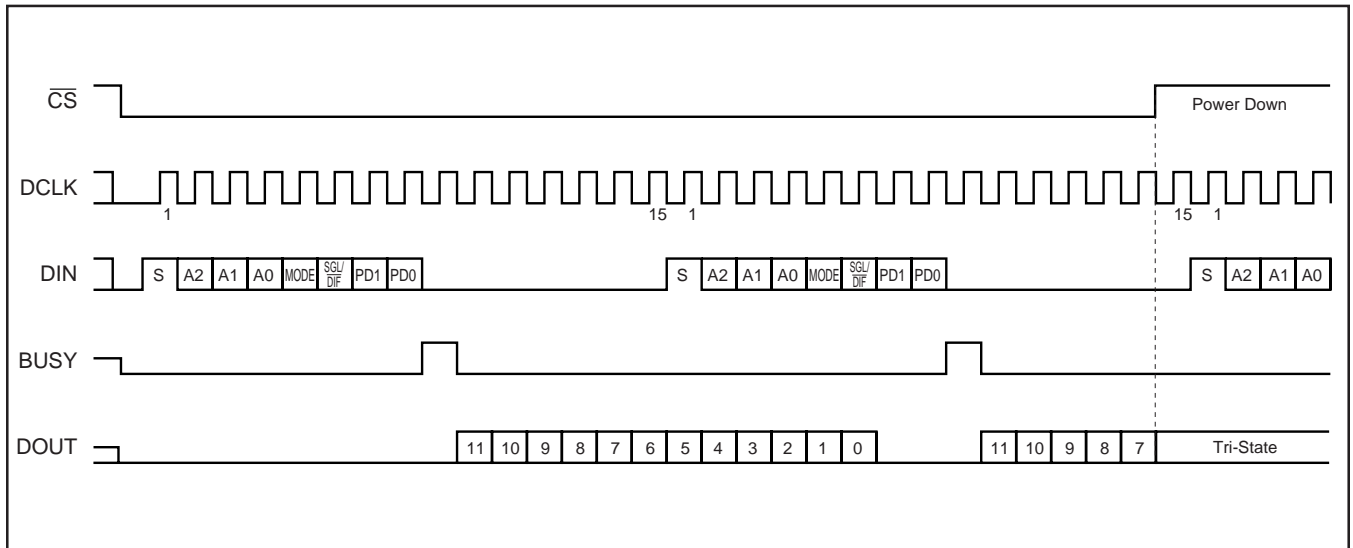

FIGURE 12. Maximum Conversion Rate, 15 Clocks per Conversion.

### 15-Clocks per Conversion

Figure 12 provides the fastest way to clock the ADS7846. This method will not work with the serial interface of most microcontrollers and digital signal processors, as they are generally not capable of providing 15 clock cycles per serial transfer. However, this method could be used with Field Programmable Gate Arrays (FPGAs) or Application Specific Integrated Circuits (ASICs). Note that this effectively increases the maximum conversion rate of the converter beyond the values given in the specification tables, which assume 16 clock cycles per conversion.

### Data Format

The ADS7846 output data is in Straight Binary format as shown in Figure 13. This figure shows the ideal output code for the given input voltage and does not include the effects of offset, gain, or noise.

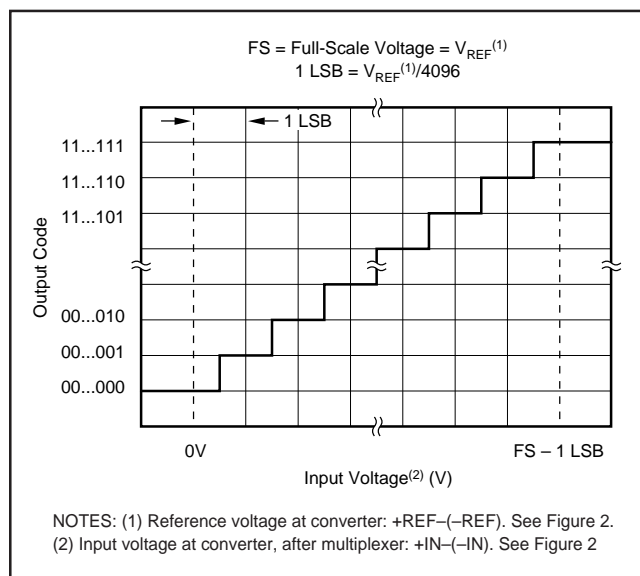

FIGURE 13. Ideal Input Voltages and Output Codes.

### 8-Bit Conversion

The ADS7846 provides an 8-bit conversion mode that can be used when faster throughput is needed and the digital result is not as critical. By switching to the 8-bit mode, a conversion is complete four clock cycles earlier. This could be used in conjunction with serial interfaces that provide 12-bit transfers, or two conversions could be accomplished with three 8-bit transfers. Not only does this shorten each conversion by four bits (25% faster throughput), but each conversion can actually occur at a faster clock rate. This is because the internal settling time of the ADS7846 is not as critical—settling to better than 8 bits is all that is needed. The clock rate can be as much as 50% faster. The faster clock rate and fewer clock cycles combine to provide a 2x increase in conversion rate.

### POWER DISSIPATION

There are two major power modes for the ADS7846: full power (PD1 - PD0 = 11<sub>B</sub>) and auto power down (PD1 - PD0 = 00<sub>B</sub>). When operating at full speed and 16-clocks per conversion (see Figure 10), the ADS7846 spends most of its time acquiring or converting. There is little time for auto power down, assuming that this mode is active. Therefore, the difference between full power mode and auto power-down is negligible. If the conversion rate is decreased by simply slowing the frequency of the DCLK input, the two modes remain approximately equal. However, if the DCLK frequency is kept at the maximum rate during a conversion, but conversions are simply done less often, the difference between the two modes is dramatic.

Figure 14 shows the difference between reducing the DCLK frequency (“scaling” DCLK to match the conversion rate) or maintaining DCLK at the highest frequency and reducing the number of conversions per second. In the later case, the converter spends an increasing percentage of its time in power-down mode (assuming the auto power-down mode is active).

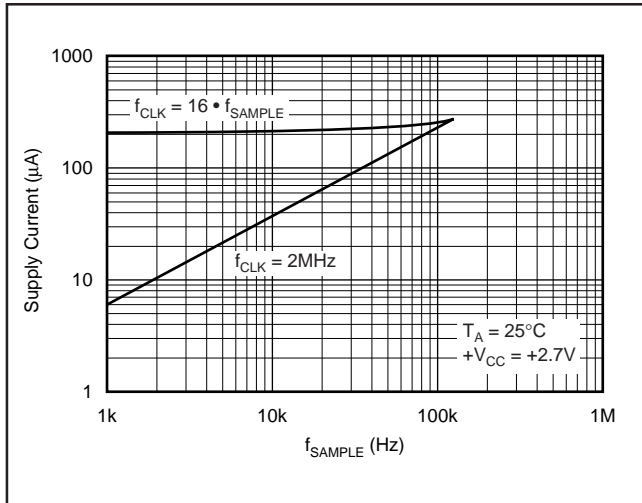

FIGURE 14. Supply Current vs Directly Scaling the Frequency of DCLK with Sample Rate or Maintaining DCLK at the Maximum Possible Frequency.

Another important consideration for power dissipation is the reference mode of the converter. In the single-ended reference mode, the converter’s internal switches are ON only when the analog input voltage is being acquired (see Figure 9 and Table V). Therefore, the external device (e.g., a resistive touch screen) is only powered during the acquisition period. In the differential reference mode, the external device must be powered throughout the acquisition and conversion periods (see Figure 9). If the conversion rate is high, this could substantially increase power dissipation.

$\overline{CS}$  will also put the ADS7846 into a power-down mode. When  $\overline{CS}$  goes HIGH, the ADS7846 immediately goes into power down and does not complete the current conversion. However, the internal reference does not turn OFF with  $\overline{CS}$  going HIGH. To turn the reference OFF, an additional write is required before  $\overline{CS}$  goes HIGH (PD1 = 0).

## LAYOUT

The following layout suggestions should provide the most optimum performance from the ADS7846. However, many portable applications have conflicting requirements concerning power, cost, size, and weight. In general, most portable devices have fairly “clean” power and grounds because most of the internal components are very low power. This situation would mean less bypassing for the converter’s power and less concern regarding grounding. Still, each situation is unique and the following suggestions should be reviewed carefully.

For optimum performance, care should be taken with the physical layout of the ADS7846 circuitry. The basic SAR architecture is sensitive to glitches or sudden changes on the power supply, reference, ground connections, and digital inputs that occur just prior to latching the output of the analog comparator. Therefore, during any single conversion for an ‘n-bit’ SAR converter, there are n ‘windows’ in which large external transient voltages can easily affect the conversion result. Such glitches might originate from switching power supplies, nearby digital logic, and high power devices. The degree of error in the digital output depends on the reference voltage, layout, and the exact timing of the external event. The error can change if the external event changes in time with respect to the DCLK input.

With this in mind, power to the ADS7846 should be clean and well bypassed. A 0.1µF ceramic bypass capacitor should be placed as close to the device as possible. A 1µF to 10µF capacitor may also be needed if the impedance of the connection between +V<sub>CC</sub> and the power supply is high.

A bypass capacitor is generally not needed because the reference is buffered by an internal op amp. If an external reference voltage originates from an op amp, make sure that it can drive any bypass capacitor that is used without oscillation.

The ADS7846 architecture offers no inherent rejection of noise or voltage variation in regards to using an external reference input. This is of particular concern when the reference input is tied to the power supply. Any noise and ripple from the supply will appear directly in the digital results. While high frequency noise can be filtered out, voltage variation due to line frequency (50Hz or 60Hz) can be difficult to remove.

The GND pin should be connected to a clean ground point. In many cases, this will be the “analog” ground. Avoid connections which are too near the grounding point of a microcontroller or digital signal processor. If needed, run a ground trace directly from the converter to the power supply entry or battery connection point. The ideal layout will include an analog ground plane dedicated to the converter and associated analog circuitry.



In the specific case of use with a resistive touch screen, care should be taken with the connection between the converter and the touch screen. Since resistive touch screens have fairly low resistance, the interconnection should be as short and robust as possible. Longer connections will be a source of error, much like the on-resistance of the internal switches. Likewise, loose connections can be a source of error when the contact resistance changes with flexing or vibrations.

As indicated previously, noise can be a major source of error in touch-screen applications (e.g., applications that require a backlit LCD panel). This EMI noise can be coupled through the LCD panel to the touch screen and cause “flickering” of the converted data. Several things can be done to reduce this error, such as utilizing a touch screen with a bottom-side metal layer connected to ground. This will couple the majority of noise to ground. Additionally, filtering capacitors, from Y+, Y-, X+, and X- to ground, can also help. Caution should be observed for settling time of the touch screen, especially operating in the single-ended mode and at high data rates.

### **PENIRQ Output**

The pen interrupt output function is detailed in Figure 15. By connecting a pull-up resistor to  $V_{CC}$  (typically  $100k\Omega$ ), the  $\overline{PENIRQ}$  output is HIGH. While in the power-down mode, with  $PD0 = PD1 = 0$ , the Y- driver is ON and connected to GND and the  $\overline{PENIRQ}$  output is connected to the X+ input. When the panel is touched, the X+ input is pulled to ground through the touch screen and  $\overline{PENIRQ}$  output goes LOW due to the current path through the panel to GND, initiating an interrupt to the processor. During the measurement cycles for X- and Y-Position, the  $\overline{PENIRQ}$  output diode will be internally connected to GND and the X+ input disconnected from the  $\overline{PENIRQ}$  diode to eliminate any leakage current from the pull-up resistor to flow through the touch screen, thus causing no errors.

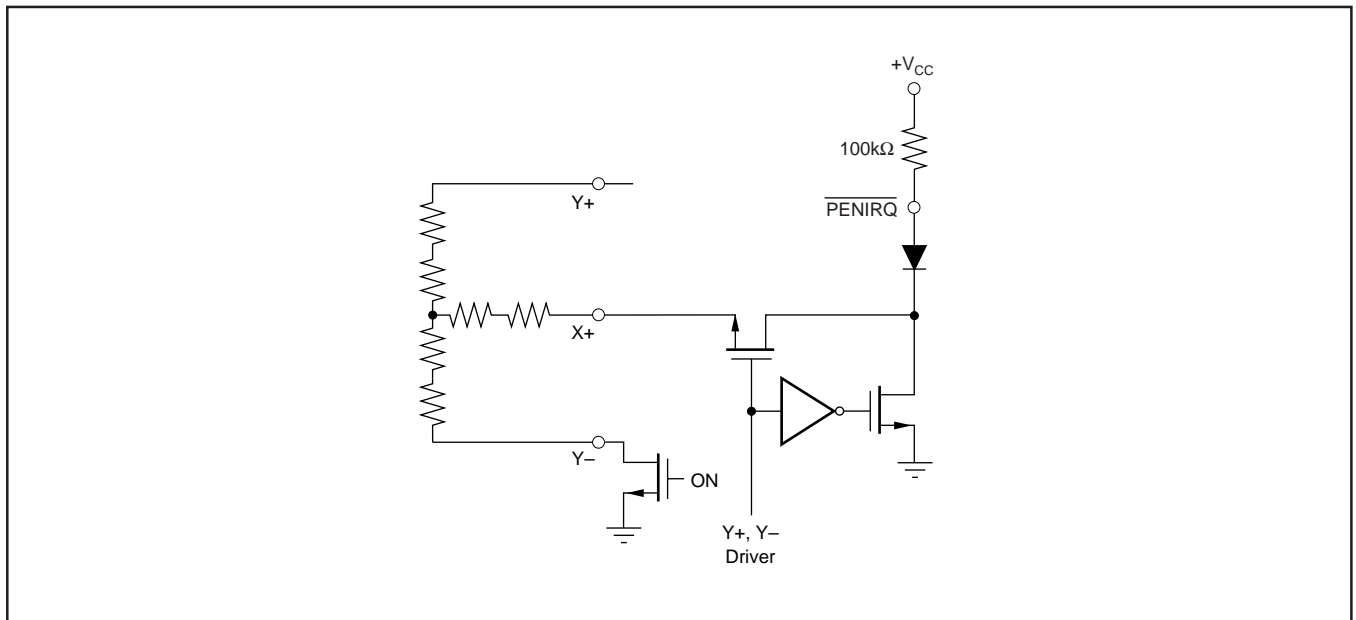

FIGURE 15. PENIRQ Functional Block Diagram.