

# DAC7614

## Quad, Serial Input, 12-Bit, Voltage Output DIGITAL-TO-ANALOG CONVERTER

### FEATURES

- LOW POWER: 20mW
- UNIPOLAR OR BIPOLAR OPERATION
- SETTLING TIME: 10 $\mu$ s to 0.012%
- 12-BIT LINEARITY AND MONOTONICITY:  
-40°C to +85°C
- USER SELECTABLE RESET TO MID-  
SCALE OR ZERO-SCALE
- SECOND-SOURCE for DAC8420
- SMALL 20-LEAD SSOP PACKAGE

### APPLICATIONS

- ATE PIN ELECTRONICS
- PROCESS CONTROL
- CLOSED-LOOP SERVO-CONTROL
- MOTOR CONTROL
- DATA ACQUISITION SYSTEMS

### DESCRIPTION

The DAC7614 is a quad, serial input, 12-bit, voltage output digital-to-analog converter (DAC) with guaranteed 12-bit monotonic performance over the -40°C to +85°C temperature range. An asynchronous reset clears all registers to either mid-scale (800<sub>H</sub>) or zero-scale (000<sub>H</sub>), selectable via the RESETSEL pin. The device can be powered from a single +5V supply or from dual +5V and -5V supplies.

Low power and small size makes the DAC7614 ideal for process control, data acquisition systems, and closed-loop servo-control. The device is available in 16-pin plastic DIP, 16-lead SOIC, or 20-lead SSOP packages, and is guaranteed over the -40°C to +85°C temperature range.

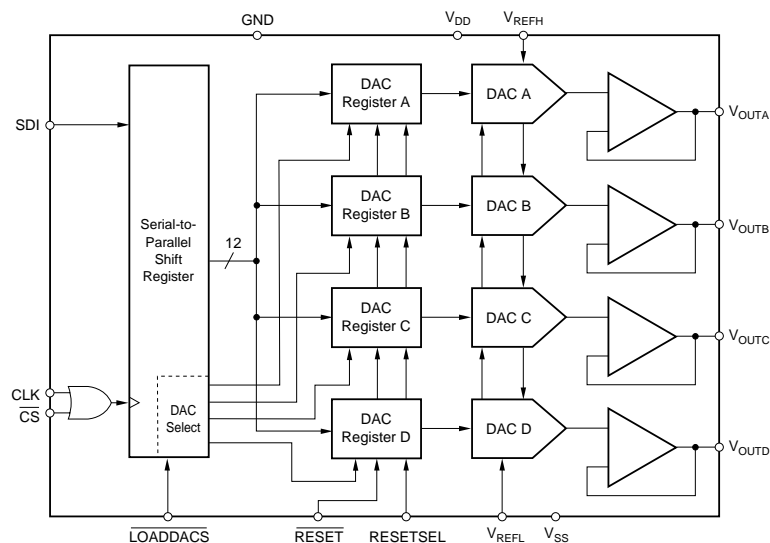

International Airport Industrial Park • Mailing Address: PO Box 11400, Tucson, AZ 85734 • Street Address: 6730 S. Tucson Blvd., Tucson, AZ 85706 • Tel: (520) 746-1111  
Twx: 910-952-1111 • Internet: <http://www.burr-brown.com/> • Cable: BBRCORP • Telex: 066-6491 • FAX: (520) 889-1510 • Immediate Product Info: (800) 548-6132

# SPECIFICATIONS

At  $T_A = -40^\circ\text{C}$  to  $+85^\circ\text{C}$ ,  $V_{DD} = +5\text{V}$ ,  $V_{SS} = -5\text{V}$ ,  $V_{REFH} = +2.5\text{V}$ , and  $V_{REFL} = -2.5\text{V}$ , unless otherwise noted.

PARAMETER	CONDITIONS	DAC7614E, P, U			DAC7614EB, PB, UB			UNITS
		MIN	TYP	MAX	MIN	TYP	MAX	
<b>ACCURACY</b>								
Linearity Error <sup>(1)</sup>	$V_{SS} = 0\text{V}$ or $-5\text{V}$			$\pm 2$			$\pm 1$	LSB <sup>(2)</sup>
Linearity Matching <sup>(3)</sup>	$V_{SS} = 0\text{V}$ or $-5\text{V}$			$\pm 2$			$\pm 1$	LSB
Differential Linearity Error	$V_{SS} = 0\text{V}$ or $-5\text{V}$			$\pm 1$			$\pm 1$	LSB
Monotonicity		12			*			Bits
Zero-Scale Error	Code = 000 <sub>H</sub>			$\pm 4$			*	LSB
Zero-Scale Drift			2	5		*	*	ppm/ $^\circ\text{C}$
Zero-Scale Matching <sup>(3)</sup>				$\pm 2$			$\pm 1$	LSB
Full-Scale Error	Code = FFF <sub>H</sub>			$\pm 4$			*	LSB
Full-Scale Matching <sup>(3)</sup>				$\pm 2$			$\pm 1$	LSB
Zero-Scale Error	Code = 00A <sub>H</sub> , $V_{SS} = 0\text{V}$			$\pm 8$			*	LSB
Zero-Scale Drift	$V_{SS} = 0\text{V}$		5	10		*	*	ppm/ $^\circ\text{C}$
Zero-Scale Matching <sup>(3)</sup>	$V_{SS} = 0\text{V}$			$\pm 4$			$\pm 2$	LSB
Full-Scale Error	Code = FFF <sub>H</sub> , $V_{SS} = 0\text{V}$			$\pm 8$			*	LSB
Full-Scale Matching <sup>(3)</sup>	$V_{SS} = 0\text{V}$			$\pm 4$			$\pm 2$	LSB
Power Supply Rejection			30			*		ppm/V
<b>ANALOG OUTPUT</b>								
Voltage Output <sup>(4)</sup>	$V_{SS} = 0\text{V}$ or $-5\text{V}$	$V_{REFL}$		$V_{REFH}$	*		*	V
Output Current		-1.25		+1.25	*		*	mA
Load Capacitance	No Oscillation		100			*		pF
Short-Circuit Current			+5, -15			*		mA
Short-Circuit Duration			Indefinite			*		
<b>REFERENCE INPUT</b>								
$V_{REFH}$ Input Range	$V_{SS} = 0\text{V}$ or $-5\text{V}$	$V_{REFL} + 1.25$		+2.5	*		*	V
$V_{REFL}$ Input Range	$V_{SS} = 0\text{V}$	0		$V_{REFH} - 1.25$	*		*	V
$V_{REFL}$ Input Range	$V_{SS} = -5\text{V}$	-2.5		$V_{REFH} - 1.25$	*		*	V
<b>DYNAMIC PERFORMANCE</b>								
Settling Time <sup>(5)</sup>	To $\pm 0.012\%$		5	10		*	*	$\mu\text{s}$
Channel-to-Channel Crosstalk	Full-Scale Step On Any Other DAC, $R_L = 2\text{k}\Omega$		0.1			*		LSB
Output Noise Voltage	Bandwidth: 0Hz to 1MHz		40			*		$\text{nV}/\sqrt{\text{Hz}}$
<b>DIGITAL INPUT/OUTPUT</b>								
Logic Family		TTL-Compatible CMOS					*	
Logic Levels								
$V_{IH}$	$ I_{IH}  \leq 10\mu\text{A}$	2.4		$V_{DD} + 0.3$	*		*	V
$V_{IL}$	$ I_{IL}  \leq 10\mu\text{A}$	-0.3		0.8	*		*	V
Data Format		Straight Binary					*	
<b>POWER SUPPLY REQUIREMENTS</b>								
$V_{DD}$		4.75		5.25	*		*	V
$V_{SS}$	If $V_{SS} \neq 0\text{V}$	-5.25		-4.75	*		*	V
$I_{DD}$			1.5	1.9		*	*	mA
$I_{SS}$		-2.1	-1.6		*	*	*	mA
Power Dissipation	$V_{SS} = -5\text{V}$		15	20		*	*	mW
	$V_{SS} = 0\text{V}$		7.5	10		*	*	mW
<b>TEMPERATURE RANGE</b>								
Specified Performance		-40		+85	*		*	$^\circ\text{C}$

\* Specification same as grade to the left.

NOTES: (1) If  $V_{SS} = 0\text{V}$ , specification applies at code 00A<sub>H</sub> and above. (2) LSB means Least Significant Bit, with  $V_{REFH}$  equal to +2.5V and  $V_{REFL}$  equal to -2.5V, one LSB is 1.22mV. (3) All DAC outputs will match within the specified error band. (4) Ideal output voltage, does not take into account zero or full-scale error. (5) If  $V_{SS} = -5\text{V}$ , full-scale step from code 000<sub>H</sub> to FFF<sub>H</sub> or vice-versa. If  $V_{SS} = 0\text{V}$ , full-scale positive step from code 000<sub>H</sub> to FFF<sub>H</sub> and negative step from code FFF<sub>H</sub> to 00A<sub>H</sub>.

The information provided herein is believed to be reliable; however, BURR-BROWN assumes no responsibility for inaccuracies or omissions. BURR-BROWN assumes no responsibility for the use of this information, and all use of such information shall be entirely at the user's own risk. Prices and specifications are subject to change without notice. No patent rights or licenses to any of the circuits described herein are implied or granted to any third party. BURR-BROWN does not authorize or warrant any BURR-BROWN product for use in life support devices and/or systems.

## ABSOLUTE MAXIMUM RATINGS<sup>(1)</sup>

V <sub>DD</sub> to V <sub>SS</sub> .....	-0.3V to +11V
V <sub>DD</sub> to GND .....	-0.3V to +5.5V
V <sub>REFL</sub> to V <sub>SS</sub> .....	-0.3V to (V <sub>DD</sub> - V <sub>SS</sub> )
V <sub>DD</sub> to V <sub>REFH</sub> .....	-0.3V to (V <sub>DD</sub> - V <sub>SS</sub> )
V <sub>REFH</sub> to V <sub>REFL</sub> .....	-0.3V to (V <sub>DD</sub> - V <sub>SS</sub> )
Digital Input Voltage to GND .....	-0.3V to V <sub>DD</sub> + 0.3V
Maximum Junction Temperature .....	+150°C
Operating Temperature Range .....	-40°C to +85°C
Storage Temperature Range .....	-65°C to +150°C
Lead Temperature (soldering, 10s) .....	+300°C

NOTE: (1) Stresses above those listed under "Absolute Maximum Ratings" may cause permanent damage to the device. Exposure to absolute maximum conditions for extended periods may affect device reliability.



## ELECTROSTATIC DISCHARGE SENSITIVITY

This integrated circuit can be damaged by ESD. Burr-Brown recommends that all integrated circuits be handled with appropriate precautions. Failure to observe proper handling and installation procedures can cause damage.

ESD damage can range from subtle performance degradation to complete device failure. Precision integrated circuits may be more susceptible to damage because very small parametric changes could cause the device not to meet its published specifications.

## PACKAGE/ORDERING INFORMATION

PRODUCT	MAXIMUM LINEARITY ERROR (LSB)	MAXIMUM DIFFERENTIAL LINEARITY (LSB)	PACKAGE	PACKAGE DRAWING NUMBER <sup>(1)</sup>	SPECIFICATION TEMPERATURE RANGE	ORDERING NUMBER <sup>(2)</sup>	TRANSPORT MEDIA
DAC7614P	±2	±1	16-Pin DIP	180	-40°C to +85°C	DAC7614P	Rails
DAC7614PB	±1	"	"	"	"	DAC7614PB	Rails
DAC7614U	±2	±1	16-Lead SOIC	211	-40°C to +85°C	DAC7614U	Rails
"	"	"	"	"	"	DAC7614U/1K	Tape and Reel
DAC7614UB	±1	±1	16-Lead SOIC	211	-40°C to +85°C	DAC7614UB	Rails
"	"	"	"	"	"	DAC7614UB/1K	Tape and Reel
DAC7614E	±2	±1	20-Lead SSOP	334	-40°C to +85°C	DAC7614E	Rails
"	"	"	"	"	"	DAC7614E/1K	Tape and Reel
DAC7614EB	±1	±1	20-Lead SSOP	334	-40°C to +85°C	DAC7614EB	Rails
"	"	"	"	"	"	DAC7614EB/1K	Tape and Reel

NOTES: (1) For detailed drawing and dimension table, please see end of data sheet, or Appendix C of Burr-Brown IC Data Book. (2) Models with a slash (/) are available only in Tape and Reel in the quantities indicated (e.g., /1K indicates 1000 devices per reel). Ordering 1000 pieces of "DAC7614EB/1K" will get a single 1000-piece Tape and Reel. For detailed Tape and Reel mechanical information, refer to Appendix B of Burr-Brown IC Data Book.

## PIN CONFIGURATION—P, U Packages

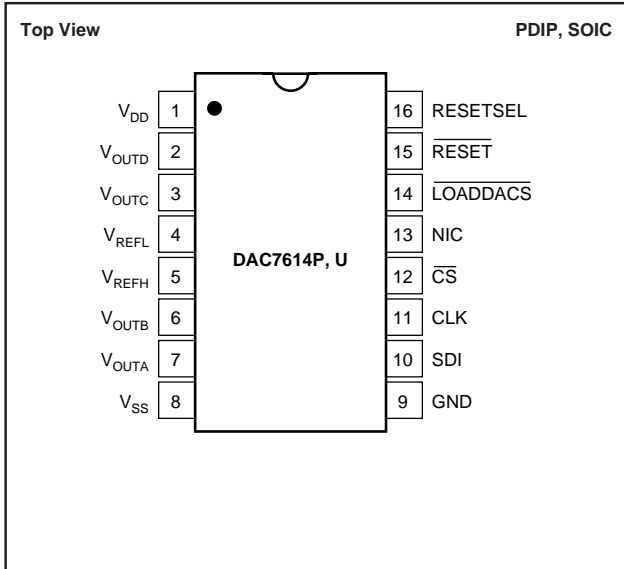

## PIN CONFIGURATION—E Package

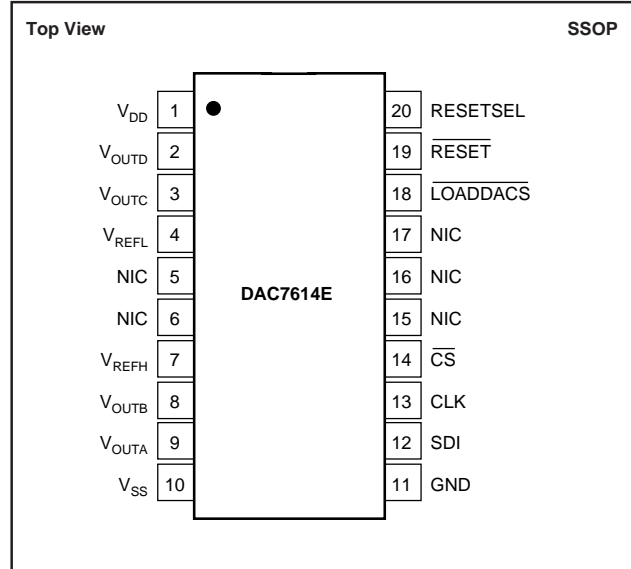

## PIN DESCRIPTIONS—P, U Packages

PIN	LABEL	DESCRIPTION
1	V <sub>DD</sub>	Positive Analog Supply Voltage, +5V nominal.
2	V <sub>OUTD</sub>	DAC D Voltage Output
3	V <sub>OUTC</sub>	DAC C Voltage Output
4	V <sub>REFL</sub>	Reference Input Voltage Low. Sets minimum output voltage for all DACs.
5	V <sub>REFH</sub>	Reference Input Voltage High. Sets maximum output voltage for all DACs.
6	V <sub>OUTB</sub>	DAC B Voltage Output
7	V <sub>OUTA</sub>	DAC A Voltage Output
8	V <sub>SS</sub>	Negative Analog Supply Voltage, 0V or –5V nominal.
9	GND	Ground
10	SDI	Serial Data Input
11	CLK	Serial Data Clock
12	CS	Chip Select Input
13	NIC	Not Internally Connected.
14	LOADDACS	The selected DAC register becomes transparent when $\overline{\text{LOADDACS}}$ is LOW. It is in the latched state when $\overline{\text{LOADDACS}}$ is HIGH.
15	RESESEL	Asynchronous Reset Input. Sets all DAC registers to either zero-scale (000 <sub>H</sub> ) or mid-scale (800 <sub>H</sub> ) when LOW. RESESEL determines which code is active.
16	RESESEL	When LOW, a LOW on $\overline{\text{RESESEL}}$ will cause all DAC registers to be set to code 000 <sub>H</sub> . When RESESEL is HIGH, a LOW on RESESEL will set the registers to code 800 <sub>H</sub> .

## PIN DESCRIPTIONS—E Package

PIN	LABEL	DESCRIPTION
1	V <sub>DD</sub>	Positive Analog Supply Voltage, +5V nominal.
2	V <sub>OUTD</sub>	DAC D Voltage Output
3	V <sub>OUTC</sub>	DAC C Voltage Output
4	V <sub>REFL</sub>	Reference Input Voltage Low. Sets minimum output voltage for all DACs.
5	NIC	Not Internally Connected.
6	NIC	Not Internally Connected.
7	V <sub>REFH</sub>	Reference Input Voltage High. Sets maximum output voltage for all DACs.
8	V <sub>OUTB</sub>	DAC B Voltage Output.
9	V <sub>OUTA</sub>	DAC A Voltage Output.
10	V <sub>SS</sub>	Negative Analog Supply Voltage, 0V or –5V nominal.
11	GND	Ground
12	SDI	Serial Data Input
13	CLK	Serial Data Clock
14	CS	Chip Select Input
15	NIC	Not Internally Connected.
16	NIC	Not Internally Connected.
17	NIC	Not Internally Connected.
18	LOADDACS	The selected DAC register becomes transparent when $\overline{\text{LOADDACS}}$ is LOW. It is in the latched state when $\overline{\text{LOADDACS}}$ is HIGH.
19	RESESEL	Asynchronous Reset Input. Sets all DAC registers to either zero-scale (000 <sub>H</sub> ) or mid-scale (800 <sub>H</sub> ) when LOW. RESESEL determines which code is active.
20	RESESEL	When LOW, a LOW on $\overline{\text{RESESEL}}$ will cause all DAC registers to be set to code 000 <sub>H</sub> . When RESESEL is HIGH, a LOW on $\overline{\text{RESESEL}}$ will set the registers to code 800 <sub>H</sub> .

# TYPICAL PERFORMANCE CURVES: $V_{SS} = 0V$

At  $T_A = +25^\circ C$ ,  $V_{DD} = +5V$ ,  $V_{SS} = 0V$ ,  $V_{REFH} = +2.5V$ , and  $V_{REFL} = 0V$ , representative unit, unless otherwise specified.

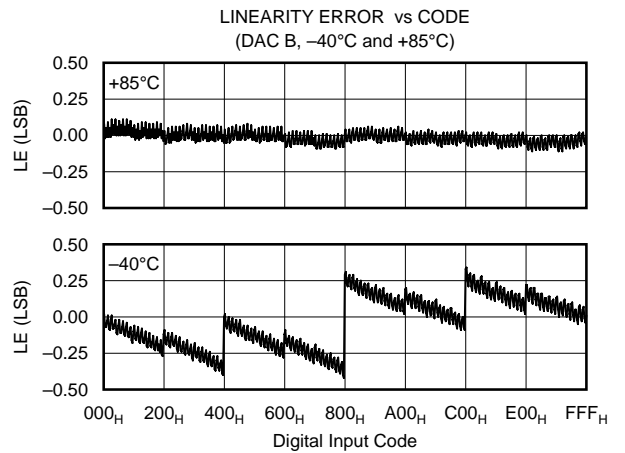
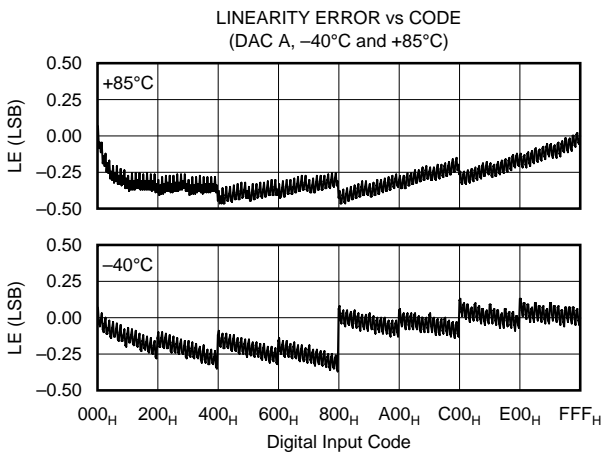
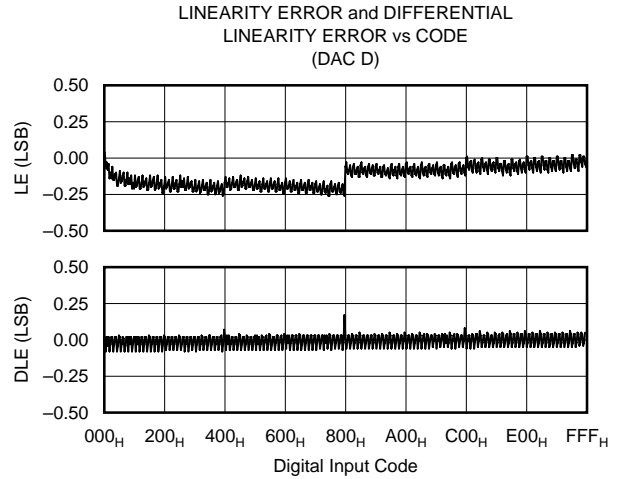
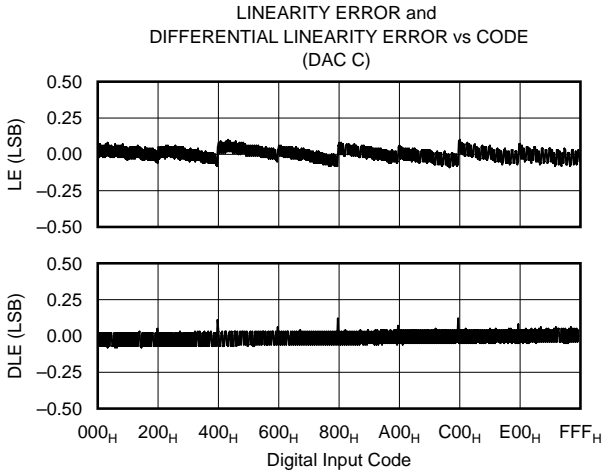
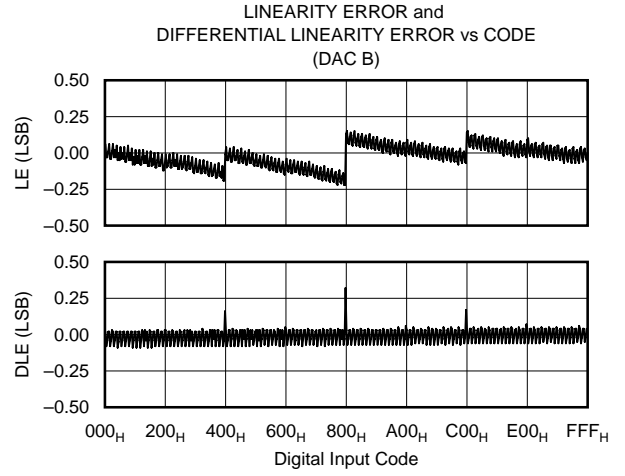
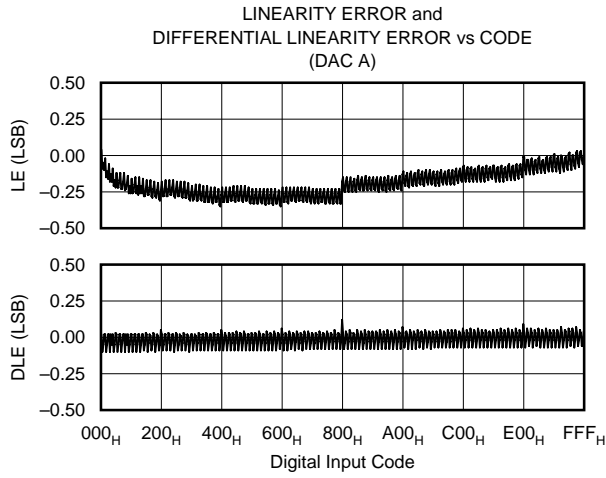

# TYPICAL PERFORMANCE CURVES: $V_{SS} = 0V$ (CONT)

At  $T_A = +25^\circ C$ ,  $V_{DD} = +5V$ ,  $V_{SS} = 0V$ ,  $V_{REFH} = +2.5V$ , and  $V_{REFL} = 0V$ , representative unit, unless otherwise specified.

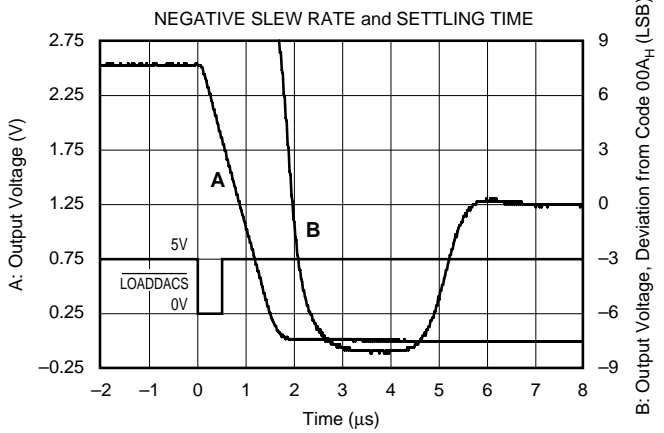
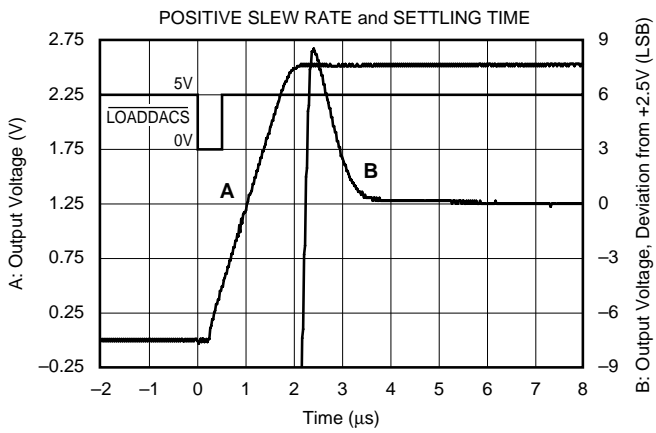
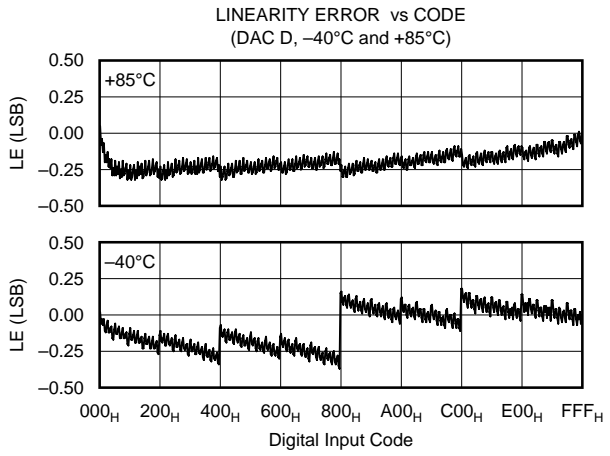
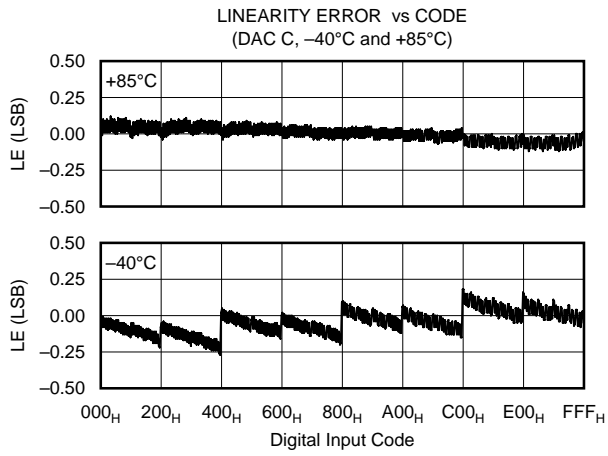

# TYPICAL PERFORMANCE CURVES: $V_{SS} = -5V$

At  $T_A = +25^\circ C$ ,  $V_{DD} = +5V$ ,  $V_{SS} = -5V$ ,  $V_{REFH} = +2.5V$ , and  $V_{REFL} = -2.5V$ , representative unit, unless otherwise specified.

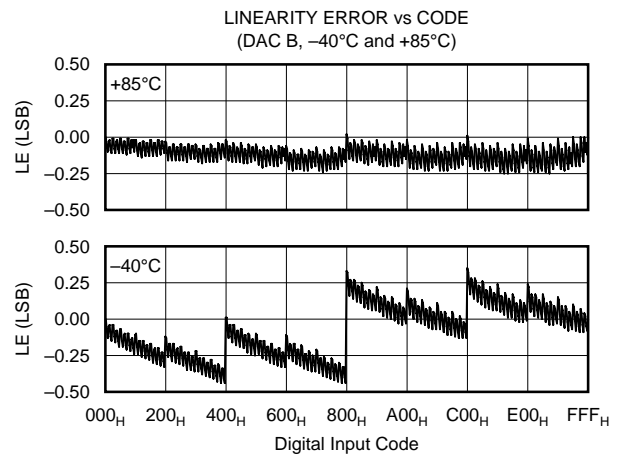
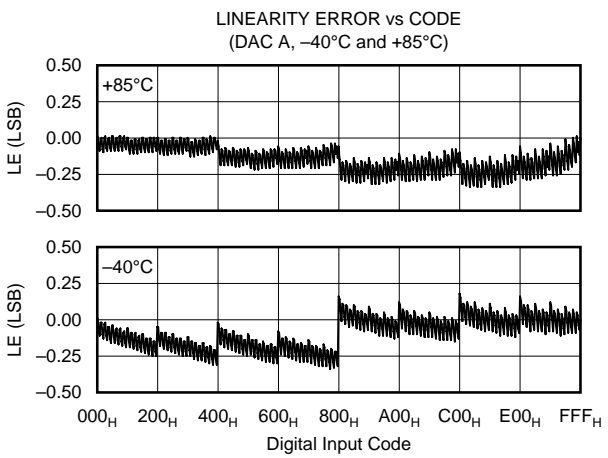
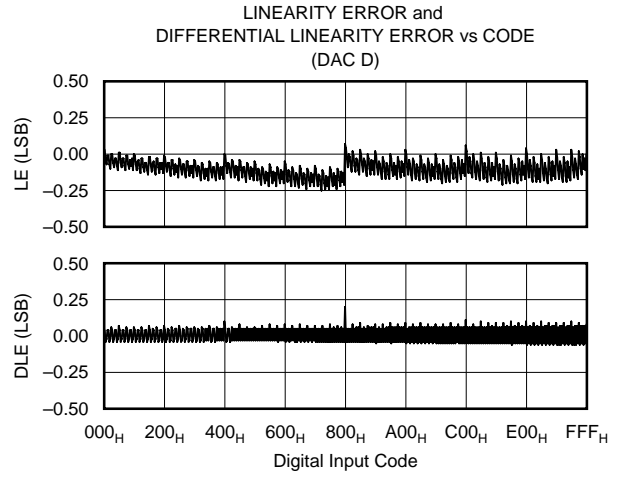
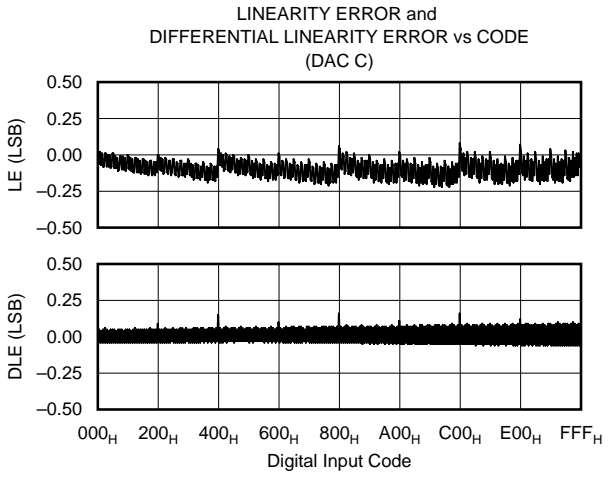
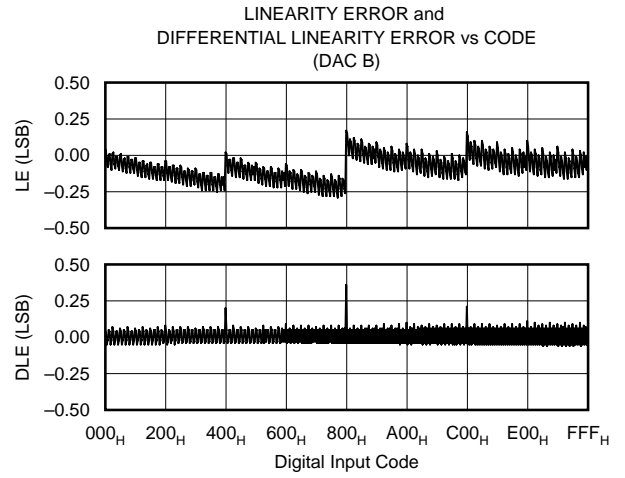
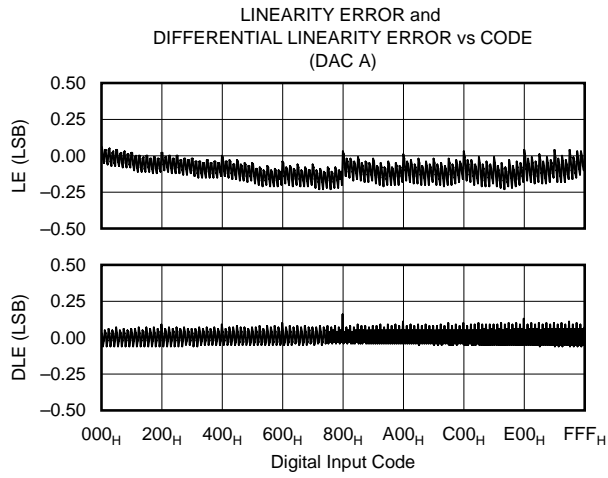

# TYPICAL PERFORMANCE CURVES: $V_{SS} = -5V$ (CONT)

At  $T_A = +25^\circ C$ ,  $V_{DD} = +5V$ ,  $V_{SS} = -5V$ ,  $V_{REFH} = +2.5V$ , and  $V_{REFL} = -2.5V$ , representative unit, unless otherwise specified.

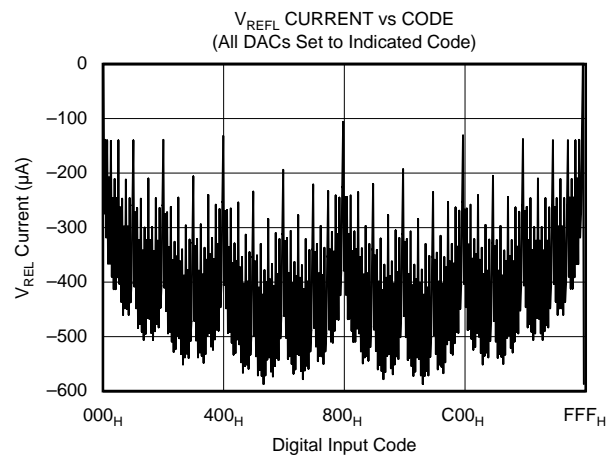
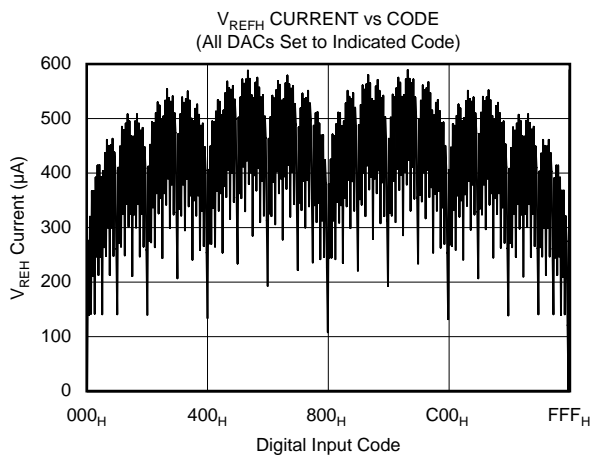
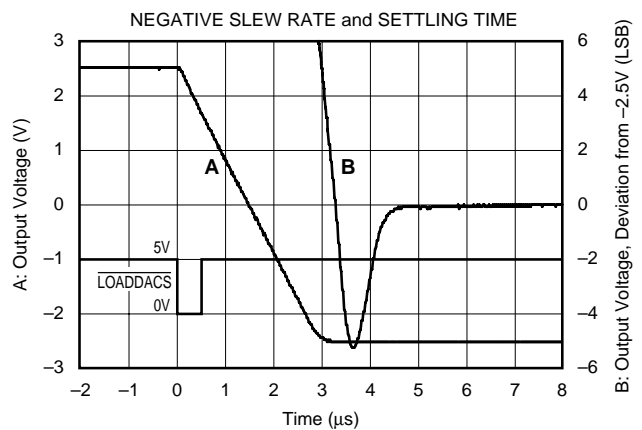
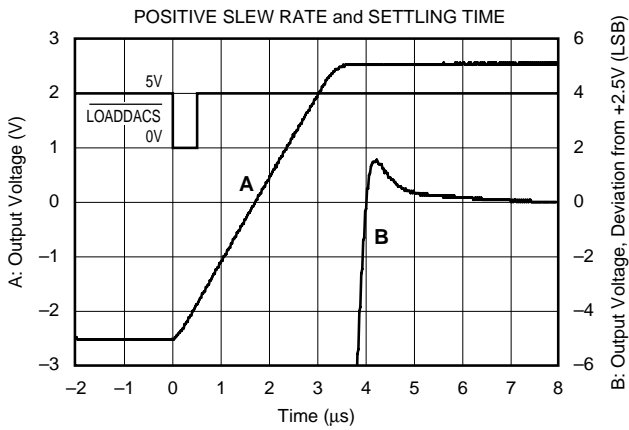
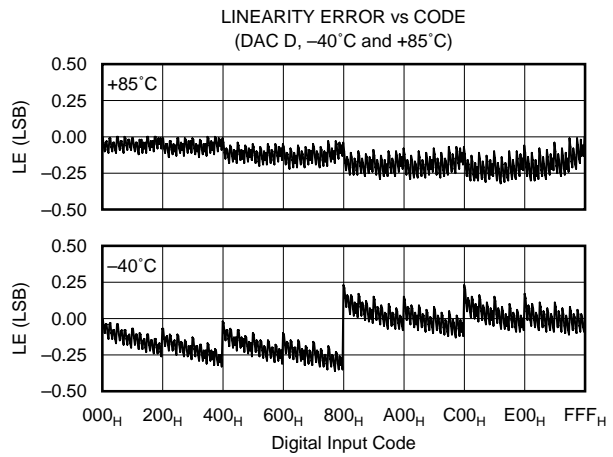
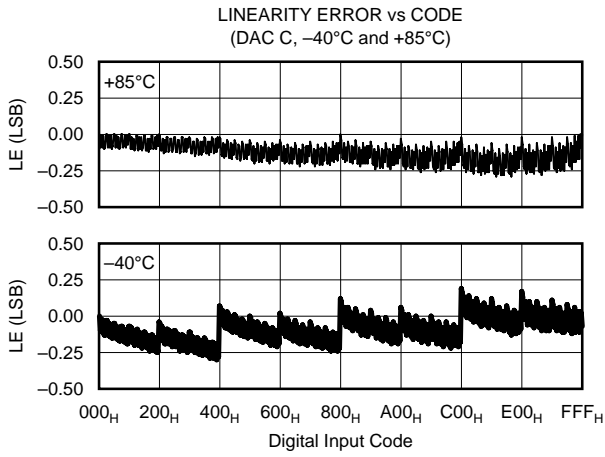



# THEORY OF OPERATION

The DAC7614 is a quad, serial input, 12-bit, voltage output DAC. The architecture is a classic R-2R ladder configuration followed by an operational amplifier that serves as a buffer. Each DAC has its own R-2R ladder network and output op amp, but all share the reference voltage inputs. The minimum voltage output (“zero-scale”) and maximum voltage output (“full-scale”) are set by external voltage references ( $V_{REFL}$  and  $V_{REFH}$ , respectively). The digital input is a 16-bit serial word that contains the 12-bit DAC code and a 2-bit address code that selects one of the four DACs (the two remaining bits are unused). The converter can be powered from a single +5V supply or a dual  $\pm 5V$  supply. Each device offers a reset function which immediately sets all DAC output voltages and internal registers to either zero-scale (code 000<sub>H</sub>) or mid-scale (code 800<sub>H</sub>). The reset code is selected by the state of the RESETSEL pin (LOW = 000<sub>H</sub>, HIGH = 800<sub>H</sub>). See Figures 1 and 2 for the basic operation of the DAC7614.

# ANALOG OUTPUTS

When  $V_{SS} = -5V$  (dual supply operation), the output amplifier can swing to within 2.25V of the supply rails, over the  $-40^{\circ}C$  to  $+85^{\circ}C$  temperature range. With  $V_{SS} = 0V$  (single-supply operation), the output can swing to ground. Note that the settling time of the output op amp will be longer with voltages very near ground. Also, care must be taken when measuring the zero-scale error when  $V_{SS} = 0V$ . If the output amplifier has a negative offset, the output voltage may not change for the first few digital input codes (000<sub>H</sub>, 001<sub>H</sub>, 002<sub>H</sub>, etc.) since the output voltage cannot swing below ground.

The behavior of the output amplifier can be critical in some applications. Under short-circuit conditions (DAC output shorted to ground), the output amplifier can sink a great deal more current than it can source. See the Specifications table for more details concerning short-circuit current.

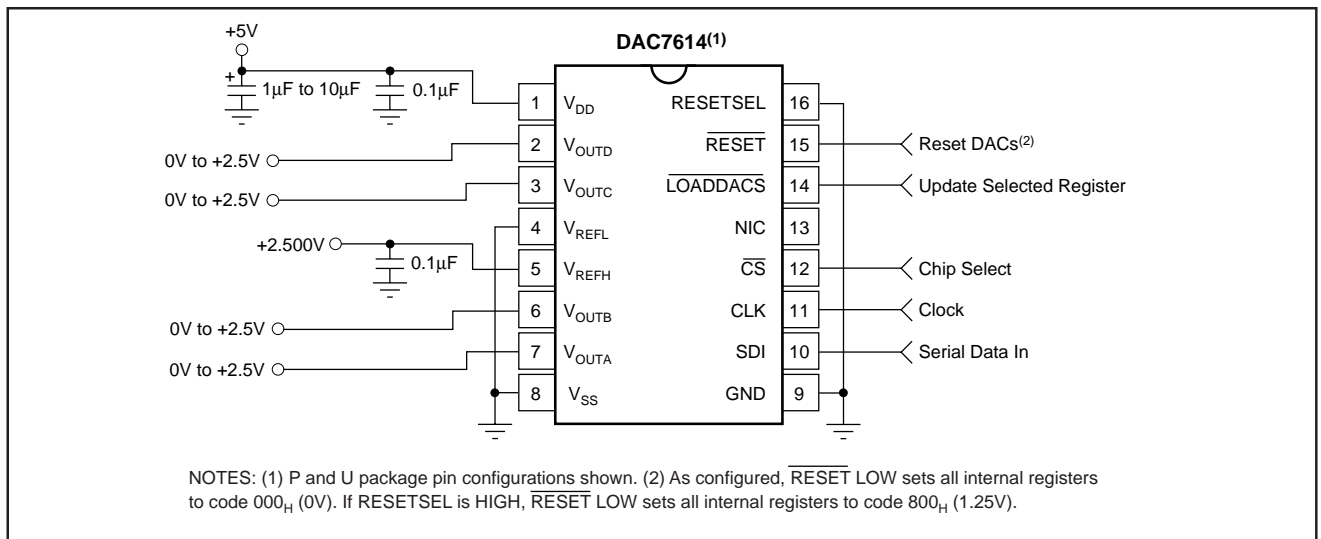

FIGURE 1. Basic Single-Supply Operation of the DAC7614.

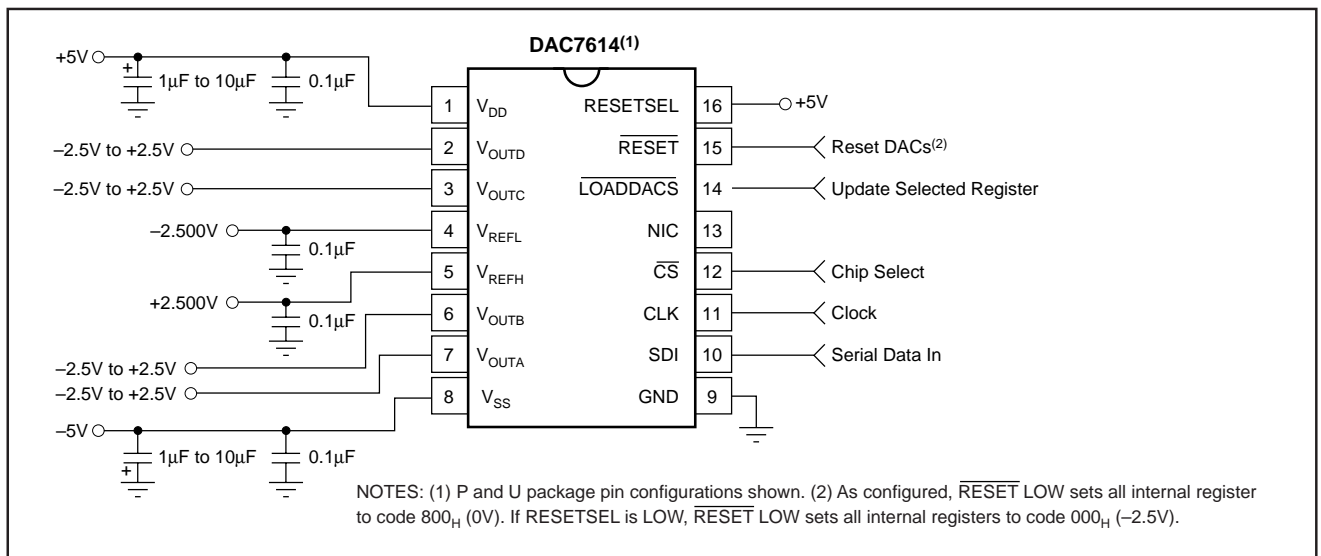

FIGURE 2. Basic Dual-Supply Operation of the DAC7614.

## REFERENCE INPUTS

The reference inputs,  $V_{REFL}$  and  $V_{REFH}$ , can be any voltage between  $V_{SS} + 2.25V$  and  $V_{DD} - 2.25V$  provided that  $V_{REFH}$  is at least 1.25V greater than  $V_{REFL}$ . The minimum output of each DAC is equal to  $V_{REFL} - 1LSB$  plus a small offset voltage (essentially, the offset of the output op amp). The maximum output is equal to  $V_{REFH}$  plus a similar offset voltage. Note that  $V_{SS}$  (the negative power supply) must either be connected to ground or must be in the range of  $-4.75V$  to  $-5.25V$ . The voltage on  $V_{SS}$  sets several bias points within the converter. If  $V_{SS}$  is not in one of these two configurations, the bias values may be in error and proper operation of the device is not guaranteed.

The current into the reference inputs depends on the DAC output voltages and can vary from a few microamps to approximately 0.6 milliamp. Bypassing the reference voltage or voltages with a 0.1 $\mu$ F capacitor placed as close as possible to the DAC7614 package is strongly recommended.

## DIGITAL INTERFACE

Figure 3 and Table I provide the basic timing for the DAC7614. The interface consists of a serial clock (CLK), serial data (SDI), and a load DAC signal (LOADDACCS). In addition, a chip select ( $\overline{CS}$ ) input is available to enable serial communication when there are multiple serial devices. An

SYMBOL	DESCRIPTION	MIN	TYP	MAX	UNITS
$t_{DS}$	Data Valid to CLK Rising	25			ns
$t_{DH}$	Data Held Valid after CLK Rises	20			ns
$t_{CH}$	CLK HIGH	30			ns
$t_{CL}$	CLK LOW	50			ns
$t_{CSS}$	$\overline{CS}$ LOW to CLK Rising	55			ns
$t_{CSH}$	CLK HIGH to $\overline{CS}$ Rising	15			ns
$t_{LD1}$	$\overline{LOADDACCS}$ HIGH to CLK Rising	40			ns
$t_{LD2}$	CLK Rising to $\overline{LOADDACCS}$ LOW	15			ns
$t_{LDDW}$	$\overline{LOADDACCS}$ LOW Time	45			ns
$t_{RSSH}$	RESETSEL Valid to $\overline{RESET}$ LOW	25			ns
$t_{RSTW}$	$\overline{RESET}$ LOW Time	70			ns
$t_s$	Settling Time	10			$\mu$ s

TABLE I. Timing Specifications ( $T_A = -40^\circ C$  to  $+85^\circ C$ ).

asynchronous reset input ( $\overline{RESET}$ ) is provided to simplify start-up conditions, periodic resets, or emergency resets to a known state.

The DAC code and address are provided via a 16-bit serial interface as shown in Figure 3. The first two bits select the DAC register that will be updated when  $\overline{LOADDACCS}$  goes LOW (see Table II). The next two bits are not used. The last 12 bits is the DAC code which is provided, most significant bit first.

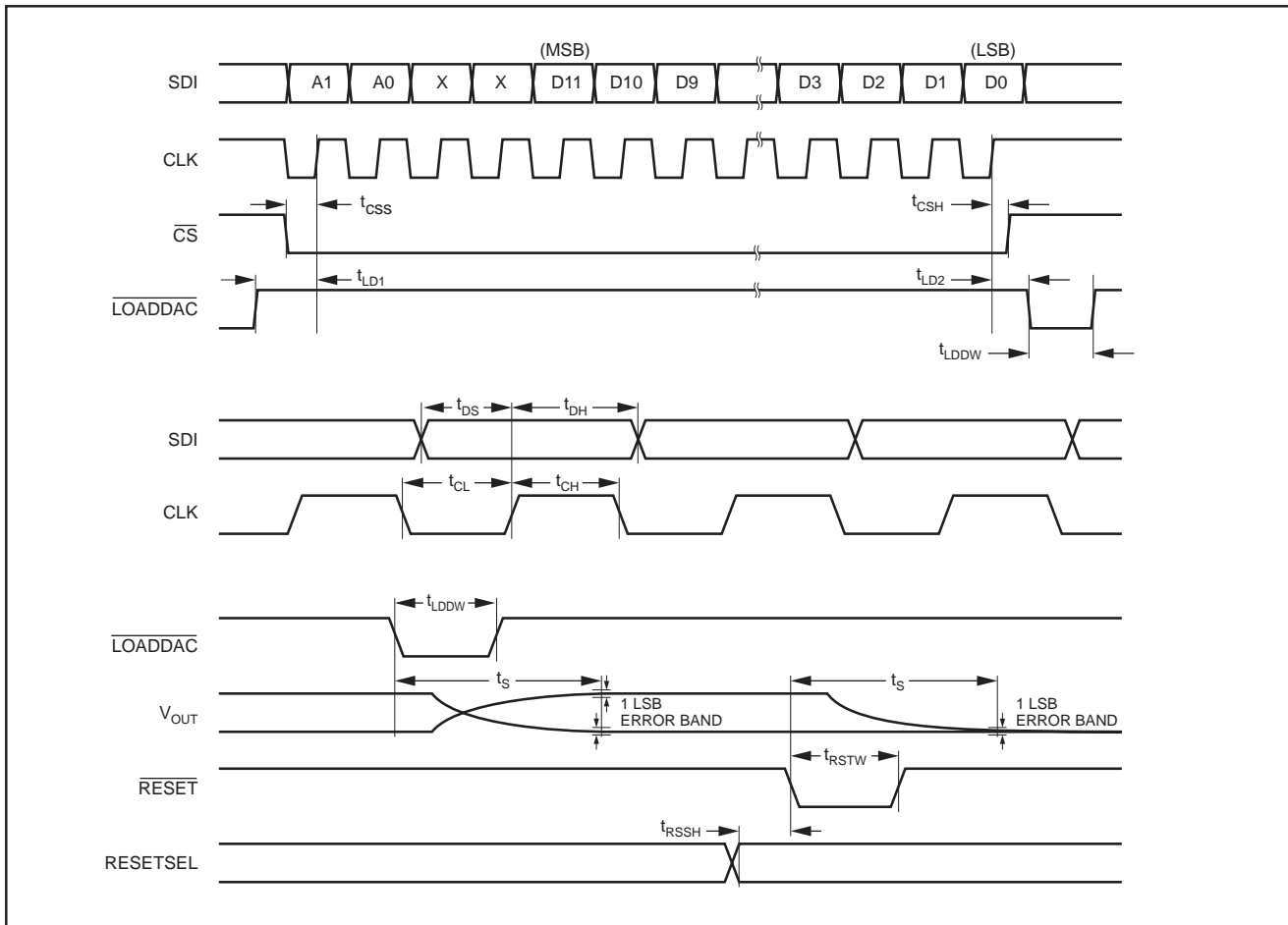

FIGURE 3. DAC7614 Timing.

A1	A0	$\overline{\text{LOADDACS}}$	$\overline{\text{RESET}}$	SELECTED DAC REGISTER	STATE OF SELECTED DAC REGISTER
L <sup>(1)</sup>	L	L	H	A	Transparent
L	H	L	H	B	Transparent
H	L	L	H	C	Transparent
H	H	L	H	D	Transparent
X <sup>(2)</sup>	X	H	H	NONE	(All Latched)
X	X	X	L	ALL	Reset <sup>(3)</sup>

NOTES: (1) L = Logic LOW. (2) X = Don't Care. (3) Resets to either 000H or 800<sub>H</sub>, per the RESETSEL state (LOW = 000<sub>H</sub>, HIGH = 800<sub>H</sub>). When  $\overline{\text{RESET}}$  rises, all registers that are in their latched state retain the reset value.

TABLE II. Control Logic Truth Table.

$\overline{\text{CS}}^{(1)}$	$\text{CLK}^{(1)}$	$\overline{\text{LOADDACS}}$	$\overline{\text{RESET}}$	SERIAL SHIFT REGISTER
H <sup>(2)</sup>	X <sup>(3)</sup>	H	H	No Change
L <sup>(4)</sup>	L	H	H	No Change
L	$\uparrow^{(5)}$	H	H	Advanced One Bit
$\uparrow$	L	H	H	Advanced One Bit
H <sup>(6)</sup>	X	L <sup>(7)</sup>	H	No Change
H <sup>(6)</sup>	X	H	L <sup>(8)</sup>	No Change

NOTES: (1)  $\overline{\text{CS}}$  and CLK are interchangeable. (2) H = Logic HIGH. (3) X = Don't Care. (4) L = Logic LOW (5) = Positive Logic Transition. (6) A HIGH value is suggested in order to avoid a "false clock" from advancing the shift register and changing the shift register. (7) If data is clocked into the serial register while  $\overline{\text{LOADDACS}}$  is LOW, the selected DAC register will change as the shift register bits "flow" through A1 and A0. This will corrupt the data in each DAC register that has been erroneously selected. (8)  $\overline{\text{RESET}}$  LOW causes no change in the contents of the serial shift register.

TABLE III. Serial Shift Register Truth Table.

Note that  $\overline{\text{CS}}$  and CLK are combined with an OR gate and the output controls the serial-to-parallel shift register internal to the DAC7614 (see the block diagram on the front of this data sheet). These two inputs are completely interchangeable. In addition, care must be taken with the state of CLK when  $\overline{\text{CS}}$  rises at the end of a serial transfer. If CLK is LOW when  $\overline{\text{CS}}$  rises, the OR gate will provide a rising edge to the shift register, shifting the internal data one additional bit. The result will be incorrect data and possible selection of the wrong DAC.

If both  $\overline{\text{CS}}$  and CLK are used, then  $\overline{\text{CS}}$  should rise only when CLK is HIGH. If not, then either  $\overline{\text{CS}}$  or CLK can be used to operate the shift register. See Table III for more information.

### Digital Input Coding

The DAC7614 input data is in Straight Binary format. The output voltage is given by the following equation:

$$V_{\text{OUT}} = V_{\text{REFL}} + \frac{(V_{\text{REFH}} - V_{\text{REFL}}) \cdot N}{4096}$$

where N is the digital input code (in decimal). This equation does not include the effects of offset (zero-scale) or gain (full-scale) errors.

# LAYOUT

A precision analog component requires careful layout, adequate bypassing, and clean, well-regulated power supplies. As the DAC7614 offers single-supply operation, it will often be used in close proximity with digital logic, microcontrollers, microprocessors, and digital signal processors. The more digital logic present in the design and the higher the switching speed, the more difficult it will be to achieve good performance from the converter.

Because the DAC7614 has a single ground pin, all return currents, including digital and analog return currents, must flow through the GND pin. Ideally, GND would be connected directly to an analog ground plane. This plane would be separate from the ground connection for the digital components until they were connected at the power entry point of the system (see Figure 4).

The power applied to  $V_{DD}$  (as well as  $V_{SS}$ , if not grounded) should be well regulated and low noise. Switching power supplies and DC/DC converters will often have high-frequency glitches or spikes riding on the output voltage. In addition, digital components can create similar high-frequency spikes as their internal logic switches states. This noise can easily couple into the DAC output voltage through various paths between the power connections and analog output.

As with the GND connection,  $V_{DD}$  should be connected to a +5V power supply plane or trace that is separate from the connection for digital logic until they are connected at the power entry point. In addition, the  $1\mu\text{F}$  to  $10\mu\text{F}$  and  $0.1\mu\text{F}$  capacitors shown in Figure 4 are strongly recommended. In some situations, additional bypassing may be required, such as a  $100\mu\text{F}$  electrolytic capacitor or even a “Pi” filter made up of inductors and capacitors—all designed to essentially lowpass filter the +5V supply, removing the high frequency noise (see Figure 4).

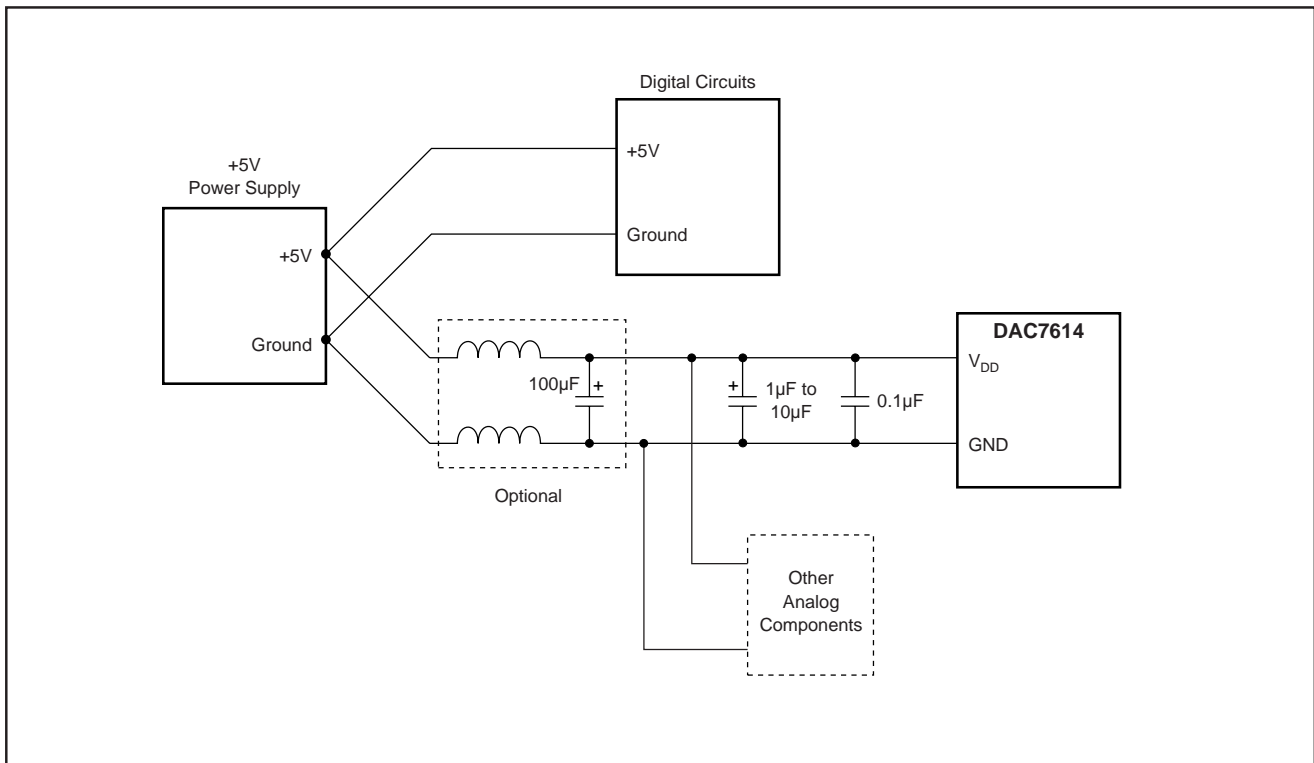

FIGURE 4. Suggested Power and Ground Connections for a DAC7614 Sharing a +5V Supply with a Digital System.