



INA156

For most current data sheet and other product information, visit [www.burr-brown.com](http://www.burr-brown.com)

## Single-Supply, Rail-to-Rail Output, CMOS INSTRUMENTATION AMPLIFIER

### FEATURES

- RAIL-TO-RAIL OUTPUT SWING: Within 20mV
- LOW OFFSET DRIFT:  $\pm 5\mu\text{V}/^\circ\text{C}$
- INTERNAL FIXED GAIN = 10V/V OR 50V/V
- SPECIFIED TEMPERATURE RANGE:  $-55^\circ\text{C}$  to  $+125^\circ\text{C}$
- LOW INPUT BIAS CURRENT: 1pA
- WIDE BANDWIDTH: 550kHz in  $G = 10$
- HIGH SLEW RATE:  $6.5\text{V}/\mu\text{s}$
- LOW COST
- TINY MSOP-8 PACKAGES

### APPLICATIONS

- INDUSTRIAL SENSOR AMPLIFIERS: Bridge, RTD, Thermocouple, Flow, Position
- MEDICAL EQUIPMENT: ECG, EEG, EMG Amplifiers
- DRIVING A/D CONVERTERS
- PCMCIA CARDS
- AUDIO PROCESSING
- COMMUNICATIONS
- TEST EQUIPMENT
- LOW COST AUTOMOTIVE INSTRUMENTATION

### DESCRIPTION

The INA156 is a low-cost CMOS instrumentation amplifier with rail-to-rail output swing optimized for low-voltage, single-supply operation.

Wide bandwidth (550kHz in  $G = 10$ ) and high slew rate ( $6.5\text{V}/\mu\text{s}$ ) make the INA156 suitable for driving sampling A/D converters as well as general purpose and audio applications. Fast settling time allows use with higher speed sensors and transducers, and rapid scanning data acquisition systems.

Gain can be set to 10V/V or 50V/V by pin strapping. Gains between these two values can be obtained with the addition of a single resistor. The INA156 is fully specified over the supply range of +2.7V to +5.5V.

The INA156 is available in an MSOP-8 surface-mount package specified for operation over the temperature range  $-55^\circ\text{C}$  to  $125^\circ\text{C}$ .

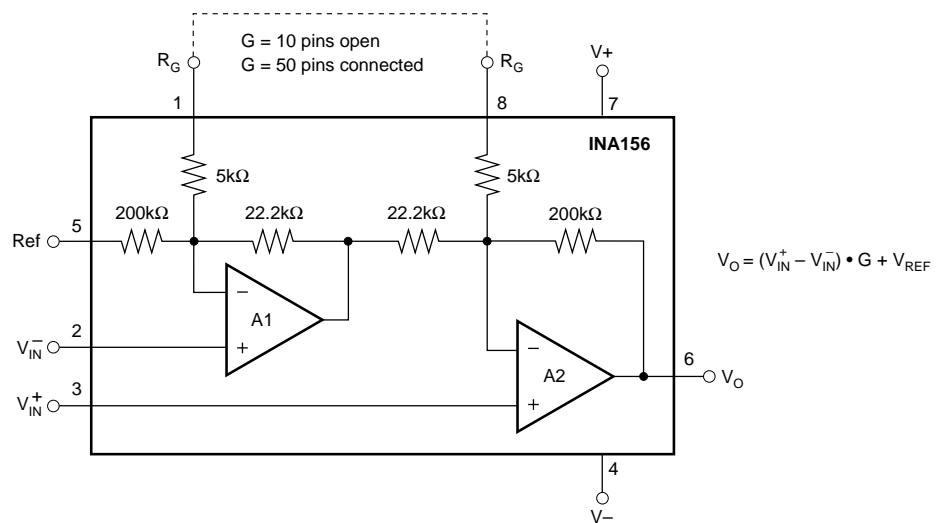

International Airport Industrial Park • Mailing Address: PO Box 11400, Tucson, AZ 85734 • Street Address: 6730 S. Tucson Blvd., Tucson, AZ 85706 • Tel: (520) 746-1111  
 Twx: 910-952-1111 • Internet: <http://www.burr-brown.com/> • Cable: BBRCORP • Telex: 066-6491 • FAX: (520) 889-1510 • Immediate Product Info: (800) 548-6132

# SPECIFICATIONS: $V_S = +2.7V$ to $+5.5V$

**Boldface** limits apply over the specified temperature range,  $T_A = -55^{\circ}C$  to  $+125^{\circ}C$

At  $T_A = +25^{\circ}C$ ,  $R_L = 10k\Omega$  connected to  $V_S/2$ .  $R_G$  pins open ( $G = 10$ ), and  $Ref = V_S/2$ , unless otherwise noted.

PARAMETER	CONDITION	INA156E, A			UNITS
		MIN	TYP	MAX	
<b>INPUT</b> Offset Voltage, RTI <b>Over Temperature</b> Drift vs Power Supply <b>Over Temperature</b> vs Time	$V_{OS}$ $V_S = +5.0V, V_{CM} = V_S/2$ $dV_{OS}/dT$ PSRR $V_S = +2.7V$ to $+6V, V_{CM} = 0.2 \cdot V_S$		$\pm 2.5$ $\pm 5$ $\pm 50$ $\pm 0.4$	$\pm 8$ $\pm 9$ $\pm 200$ $\pm 250$	mV mV $\mu V/^{\circ}C$ $\mu V/V$ $\mu V/V$ $\mu V/mo$
<b>INPUT VOLTAGE RANGE</b> Safe Input Voltage Common-Mode Range <sup>(1)</sup> Common-Mode Rejection Ratio <b>Over Temperature</b> <b>Over Temperature</b>	$V_{CM}$ $V_S = 5.5V$ $V_S = 2.7V$ CMRR $V_S = 5.5V, 0.6V < V_{CM} < 3.7V, G = 10$ $V_S = 5.5V, 0.6V < V_{CM} < 3.7V, G = 50$	(V-) - 0.5 0.3 0.2 66 <b>65</b> 74 <b>73</b>	78 87	(V+) + 0.5 5.2 <sup>(2)</sup> 2.5 <sup>(2)</sup>	V V V dB dB dB
<b>INPUT IMPEDANCE</b> Differential Common-Mode			$10^{13} \parallel 3$ $10^{13} \parallel 3$		$\Omega \parallel pF$ $\Omega \parallel pF$
<b>INPUT BIAS CURRENT</b> Input Bias Current Offset Current	$I_B$ $I_{OS}$		$\pm 1$ $\pm 1$	$\pm 10$ $\pm 10$	pA pA
<b>NOISE, RTI</b> Voltage Noise: $f = 0.1Hz$ to $10Hz$ Voltage Noise Density: $f = 10Hz$ $f = 100Hz$ $f = 1kHz$ Current Noise: $f = 1kHz$	$R_S = 0\Omega, G = 10$ or $50$		4.5 260 99 40 2		$\mu V/V_{p-p}$ $nV/\sqrt{Hz}$ $nV/\sqrt{Hz}$ $nV/\sqrt{Hz}$ $fA/\sqrt{Hz}$
<b>GAIN</b> Gain Equation Gain Error <sup>(3)</sup> <b>vs Temperature</b> <b>vs Temperature</b> Nonlinearity <b>Over Temperature</b>	$V_S = 5.5V, V_O = 0.02V$ to $5.48V, G = 10$ $V_S = 5.5V, V_O = 0.05V$ to $5.45V, G = 50$ $V_S = 5.5V, G = 10$ or $50$	10 $G = 10 + 400k\Omega/(10k\Omega + R_G)$	$\pm 0.08$ $\pm 2$ $\pm 0.1$ $\pm 15$ $\pm 0.005$	50 V/V $\pm 0.4$ $\pm 10$ $\pm 0.8$ $\pm 30$ $\pm 0.015$ $\pm 0.015$	% % ppm/ $^{\circ}C$ % ppm/ $^{\circ}C$ % of FSR % of FSR
<b>OUTPUT</b> Voltage Output Swing from Rail <b>Over Temperature</b> Short-Circuit Current Capacitance Load (stable operation)	$G = 10, R_L = 10k\Omega, G_{ERR} < 0.4\%$ Short-Circuit to Ground		5 $\pm 50$ See Typical Curve	20 <b>20</b>	mV mV mA
<b>FREQUENCY RESPONSE</b> Bandwidth, -3dB Slew Rate Settling Time: 0.1% 0.01% Overload Recovery Total Harmonic Distortion + Noise	BW SR $t_S$ THD+N $V_S = 5.5V, C_L = 100pF$ $V_S = 5.5V, V_O = 2V$ Step, $C_L = 100pF, G = 10$ $V_S = 5.5V, V_O = 2V$ Step, $C_L = 100pF, G = 50$ $V_S = 5.5V, V_O = 2V$ Step, $C_L = 100pF, G = 10$ $V_S = 5.5V, V_O = 2V$ Step, $C_L = 100pF, G = 50$ 50% Input Overload	$G = 10$ $G = 50$	550 110 6.5 5 11 8 15 0.2 See Typical Curve		kHz kHz V/ $\mu s$ $\mu s$ $\mu s$ $\mu s$ $\mu s$ $\mu s$
<b>POWER SUPPLY</b> Specified Voltage Range Operating Voltage Range Quiescent Current <b>Over Temperature</b>	$V_{IN} = 0, I_O = 0$ $V_{IN} = 0, I_O = 0$	+2.7	+2.5 to +6 1.8	+5.5 2.5 <b>3.2</b>	V V mA mA
<b>TEMPERATURE RANGE</b> Specified Range Operating Range Storage Range Thermal Resistance MSOP-8 Surface Mount SO-8 Surface Mount	$\theta_{JA}$	-55 -65 -65		+125 +150 +150	$^{\circ}C$ $^{\circ}C$ $^{\circ}C$ $^{\circ}C/W$ $^{\circ}C/W$

NOTES: (1) For further information, refer to typical performance curves on common-mode input range. (2) Operation beyond (V+) - 1.8V (max) results in reduced common-mode rejection. See discussion and Figure 6 in the text of this data sheet. (3) Does not include error and TCR of additional optional gain-setting resistor in series with  $R_G$ , if used.

## PIN CONFIGURATION

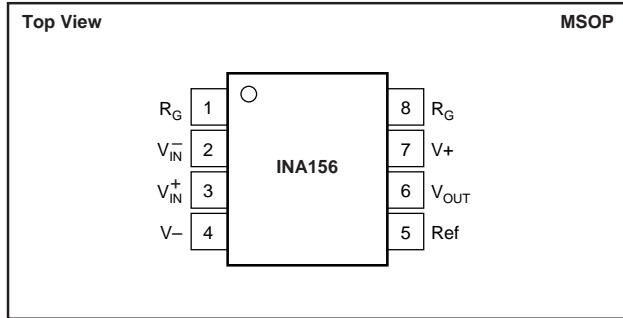

## ELECTROSTATIC DISCHARGE SENSITIVITY

This integrated circuit can be damaged by ESD. Burr-Brown recommends that all integrated circuits be handled with appropriate precautions. Failure to observe proper handling and installation procedures can cause damage.

ESD damage can range from subtle performance degradation to complete device failure. Precision integrated circuits may be more susceptible to damage because very small parametric changes could cause the device not to meet its published specifications.

## ABSOLUTE MAXIMUM RATINGS<sup>(1)</sup>

Supply Voltage, $V^+$ to $V^-$ .....	7.5V
Signal Input Terminals, Voltage <sup>(2)</sup> .....	$(V^-) - 0.5V$ to $(V^+) + 0.5V$
Current <sup>(2)</sup> .....	10mA
Output Short-Circuit <sup>(3)</sup> .....	Continuous
Operating Temperature .....	$-65^\circ\text{C}$ to $+150^\circ\text{C}$
Storage Temperature .....	$-65^\circ\text{C}$ to $+150^\circ\text{C}$
Junction Temperature .....	$+150^\circ\text{C}$
Lead Temperature (soldering, 10s) .....	$+300^\circ\text{C}$

NOTES: (1) Stresses above these ratings may cause permanent damage. Exposure to absolute maximum conditions for extended periods may degrade device reliability. These are stress ratings only, and functional operation of the device at these or any other conditions beyond those specified is not implied. (2) Input terminals are diode-clamped to the power supply rails. Input signals that can swing more than 0.5V beyond the supply rails should be current limited to 10mA or less. (3) Short circuit to ground.

## PACKAGE/ORDERING INFORMATION

PRODUCT	PACKAGE	PACKAGE DRAWING NUMBER	SPECIFIED TEMPERATURE RANGE	PACKAGE MARKING	ORDERING NUMBER <sup>(1)</sup>	TRANSPORT MEDIA
INA156 EA	MSOP-8	337	$-55^\circ\text{C}$ to $+125^\circ\text{C}$	A56	INA156EA/250	Tape and Reel
"	"	"	"	"	INA156EA/2K5	Tape and Reel

NOTE: (1) Models with a slash (/) are available only in Tape and Reel in the quantities indicated (e.g., /2K5 indicates 2500 devices per reel). Ordering 2500 pieces of "INA156EA/2K5" will get a single 2500-piece Tape and Reel.

The information provided herein is believed to be reliable; however, BURR-BROWN assumes no responsibility for inaccuracies or omissions. BURR-BROWN assumes no responsibility for the use of this information, and all use of such information shall be entirely at the user's own risk. Prices and specifications are subject to change without notice. No patent rights or licenses to any of the circuits described herein are implied or granted to any third party. BURR-BROWN does not authorize or warrant any BURR-BROWN product for use in life support devices and/or systems.

# TYPICAL PERFORMANCE CURVES

At  $T_A = +25^\circ\text{C}$ ,  $V_S = 5.5\text{V}$ ,  $R_L = 10\text{k}\Omega$  connected to  $V_S/2$ .  $R_G$  pins open ( $G = 10$ ), and  $\text{Ref} = V_S/2$ , unless otherwise noted.

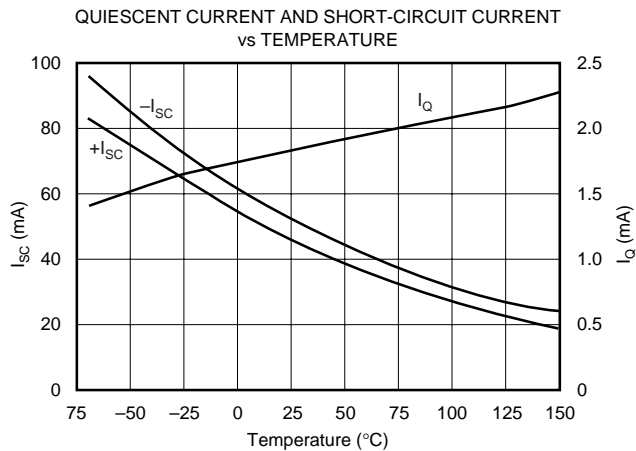
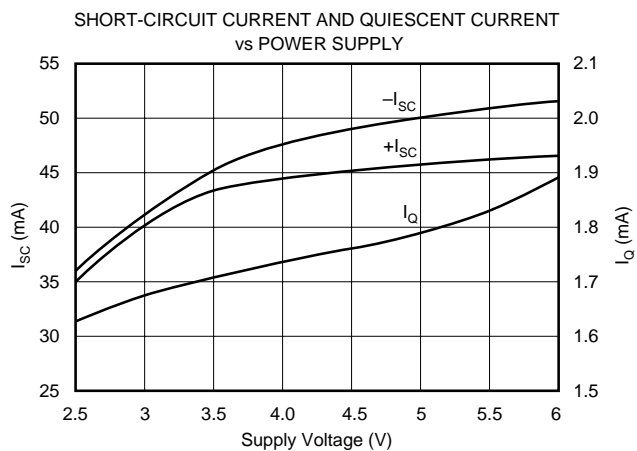
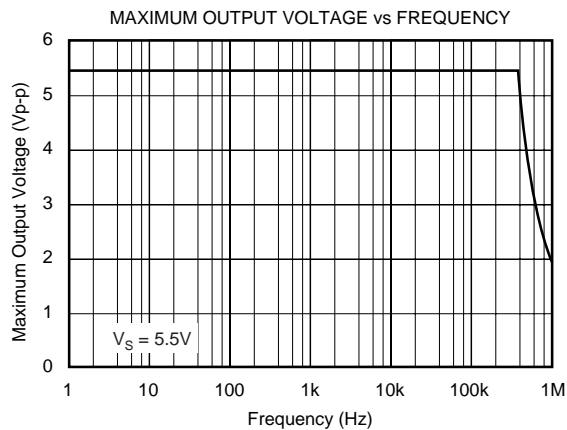
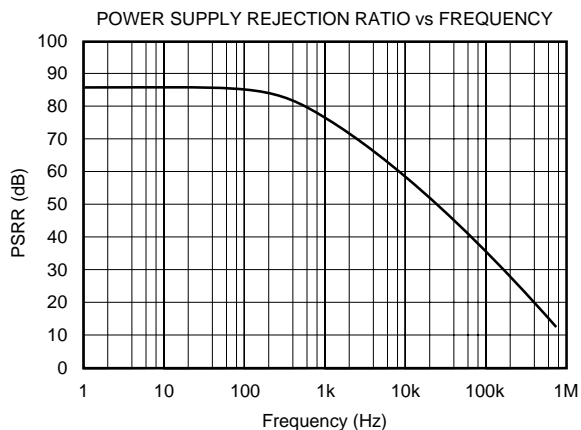
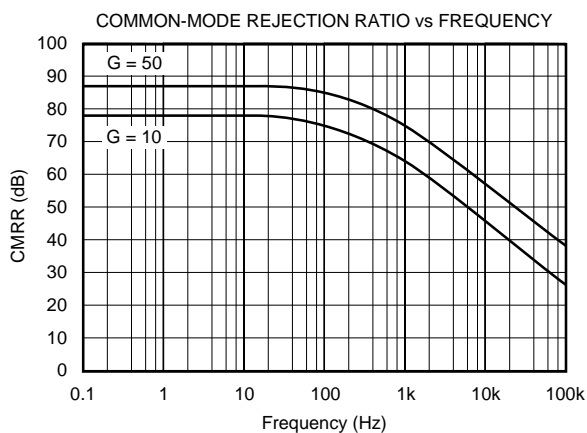
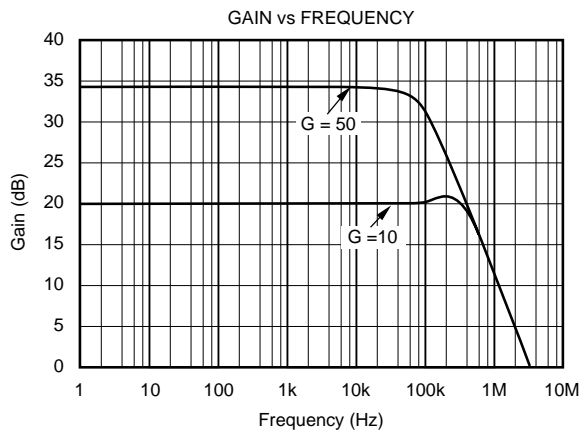

# TYPICAL PERFORMANCE CURVES (Cont.)

At  $T_A = +25^\circ\text{C}$ ,  $V_S = 5.5\text{V}$ ,  $R_L = 10\text{k}\Omega$  connected to  $V_S/2$ .  $R_G$  pins open ( $G = 10$ ), and  $\text{Ref} = V_S/2$ , unless otherwise noted.

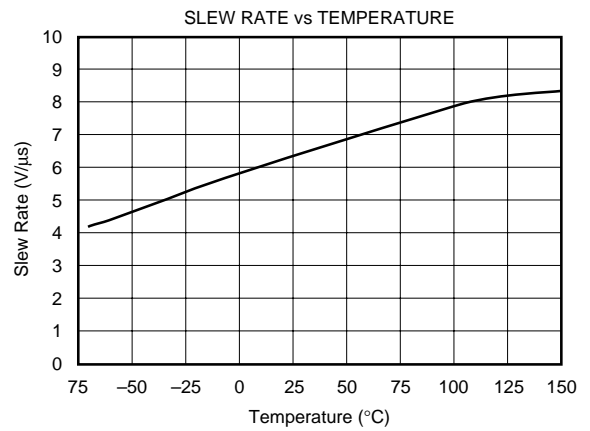
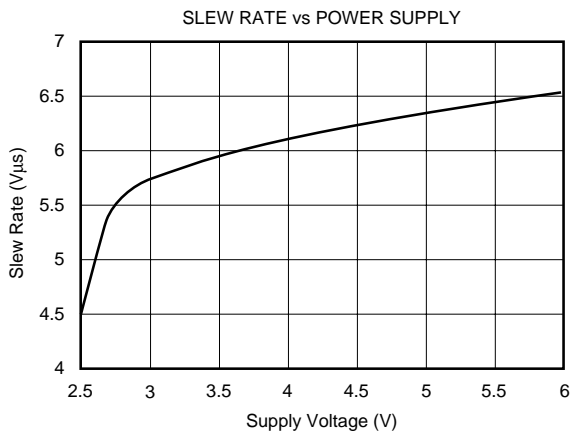
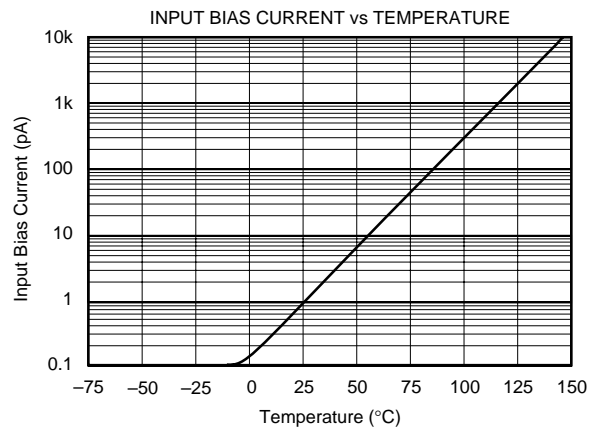
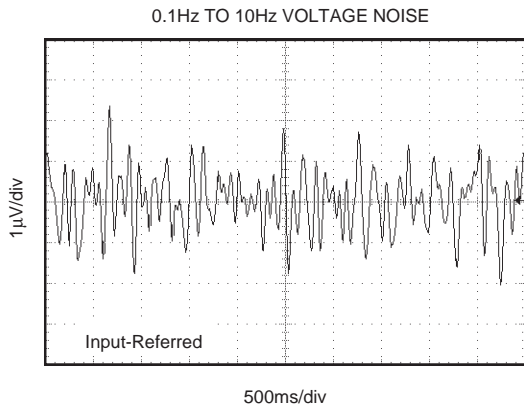
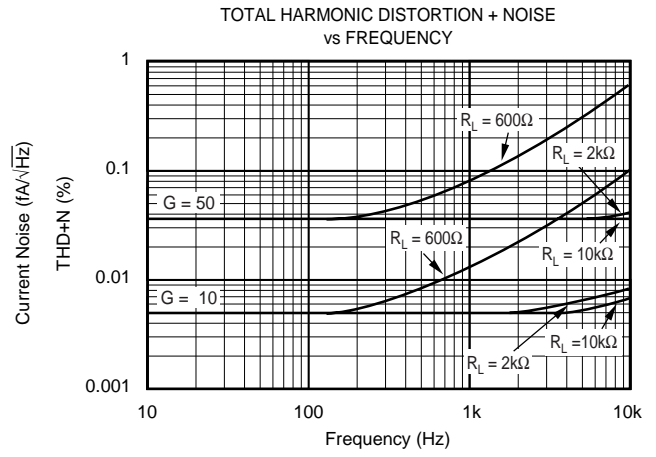
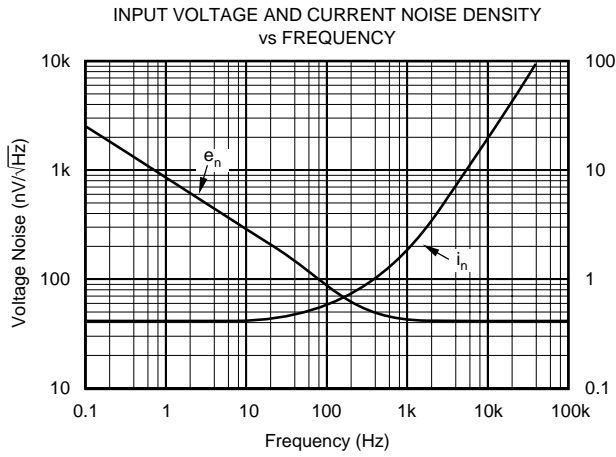

# TYPICAL PERFORMANCE CURVES (Cont.)

At  $T_A = +25^\circ\text{C}$ ,  $V_S = 5.5\text{V}$ ,  $R_L = 10\text{k}\Omega$  connected to  $V_S/2$ .  $R_G$  pins open ( $G = 10$ ), and  $\text{Ref} = V_S/2$ , unless otherwise noted.

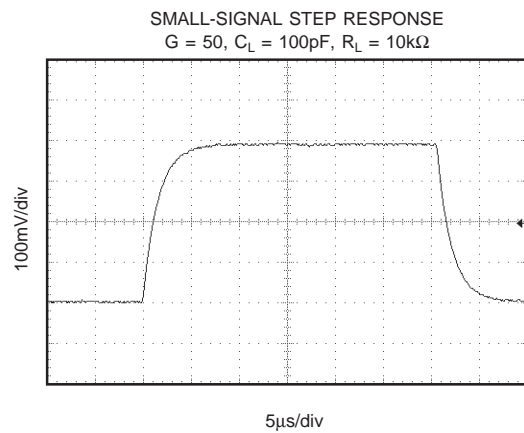
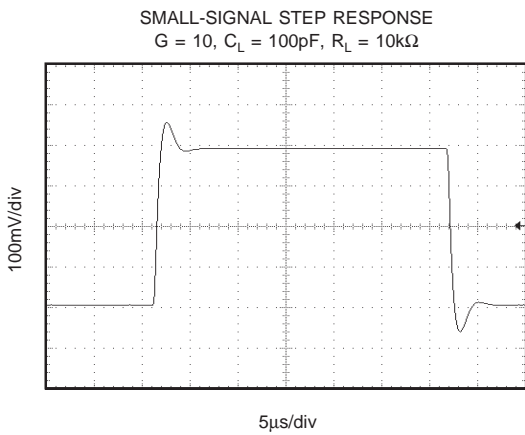
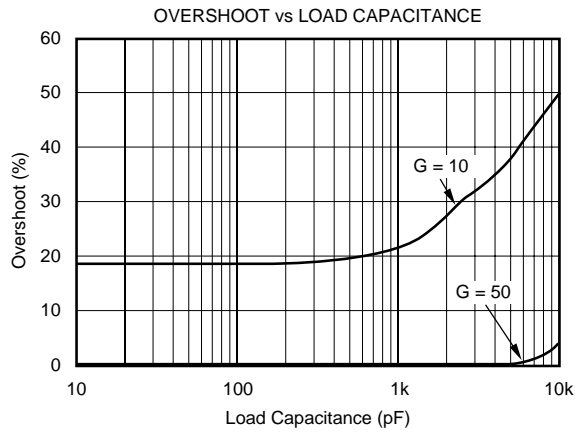
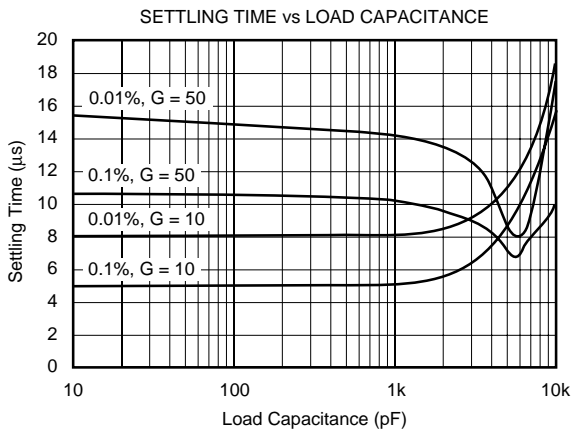
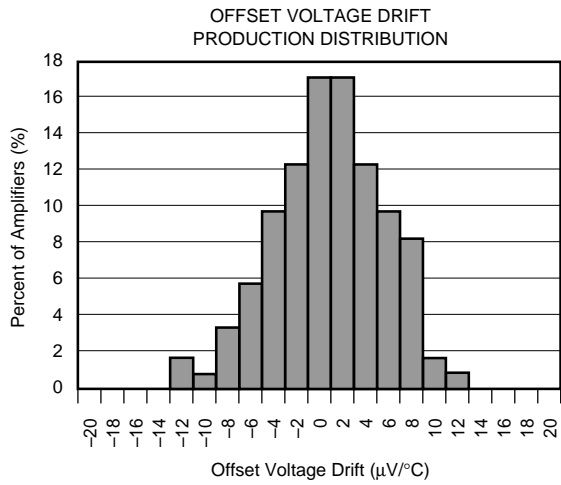
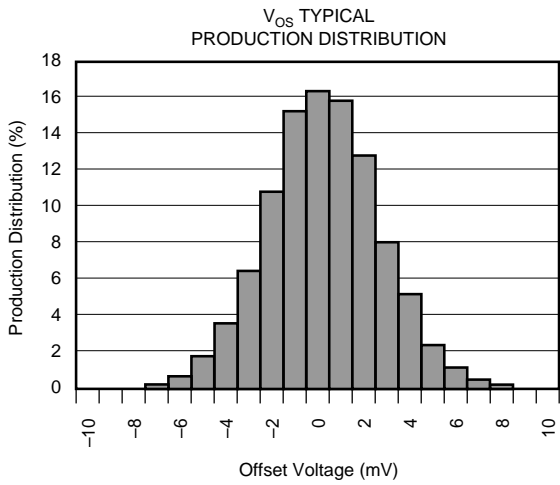

# TYPICAL PERFORMANCE CURVES (Cont.)

At  $T_A = +25^\circ\text{C}$ ,  $V_S = 5.5\text{V}$ ,  $R_L = 10\text{k}\Omega$  connected to  $V_S/2$ .  $R_G$  pins open ( $G = 10$ ), and  $\text{Ref} = V_S/2$ , unless otherwise noted.

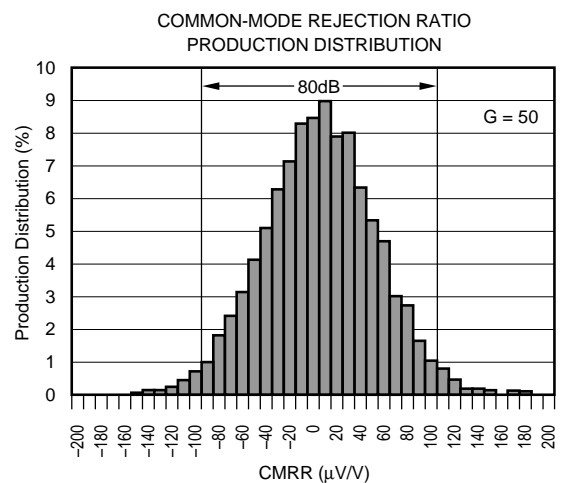
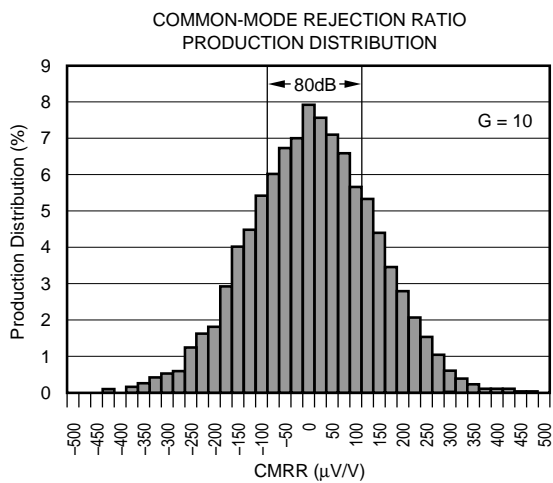
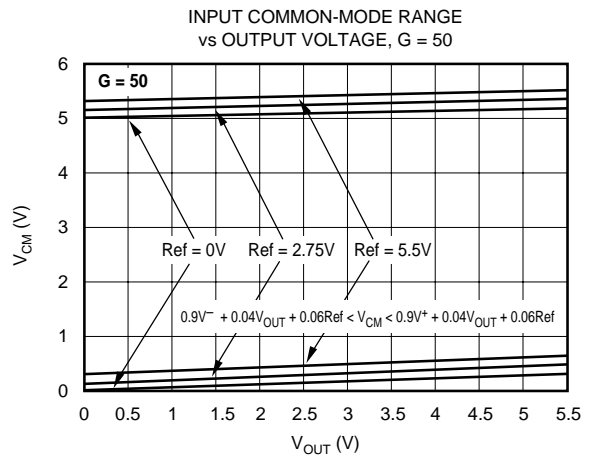
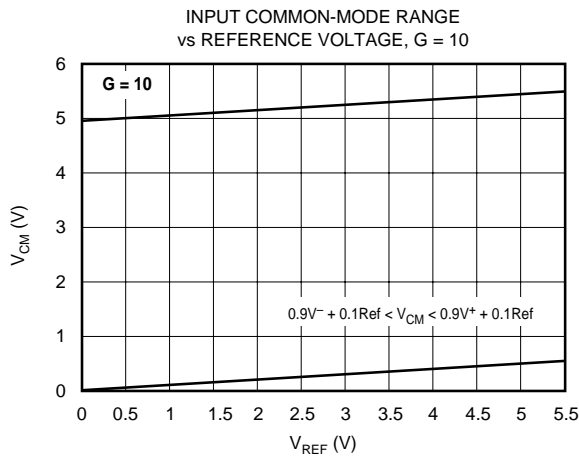
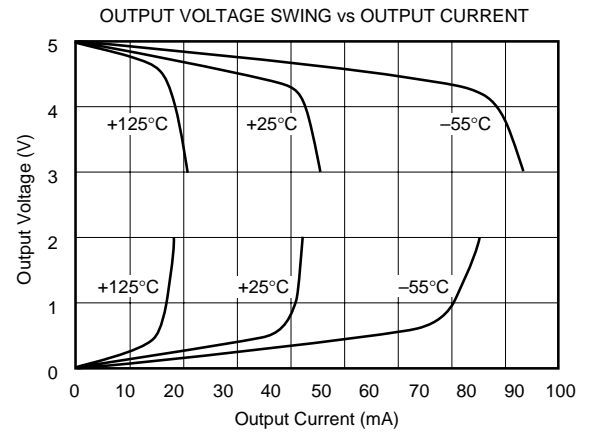
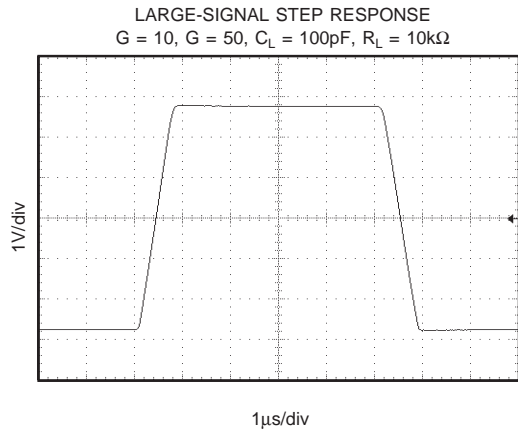

# APPLICATIONS INFORMATION

Figure 1 shows the basic connections required for operation of the INA156. Applications with noisy or high impedance power supplies may require decoupling capacitors close to the device pins, as shown.

The output is referred to the output reference terminal, Ref, which is normally set to  $V_S/2$ . This must be a low-impedance connection to ensure good common-mode rejection.

In addition, for the  $G = 50$  configuration, the connection between pins 1 and 8 must be low-impedance. A connection impedance of  $20\Omega$  can cause a 0.2% shift in gain error.

# OPERATING VOLTAGE

The INA156 is fully specified and guaranteed over the supply range  $+2.7V$  to  $+5.5V$ , with key parameters guaranteed over the temperature range of  $-55^\circ C$  to  $+125^\circ C$ . Parameters that vary significantly with operating voltages, load conditions or temperature are shown in the Typical Performance Curves.

The INA156 can be operated from either single or dual power supplies. By adjusting the voltage applied to the reference terminal, the input common-mode voltage range and the output range can be adjusted within the bounds shown in the Typical Performance Curves. Figure 2 shows a bridge amplifier circuit operated from a single  $+5V$  power supply. The bridge provides a relatively small differential voltage on top of an input common-mode voltage near  $2.5V$ .

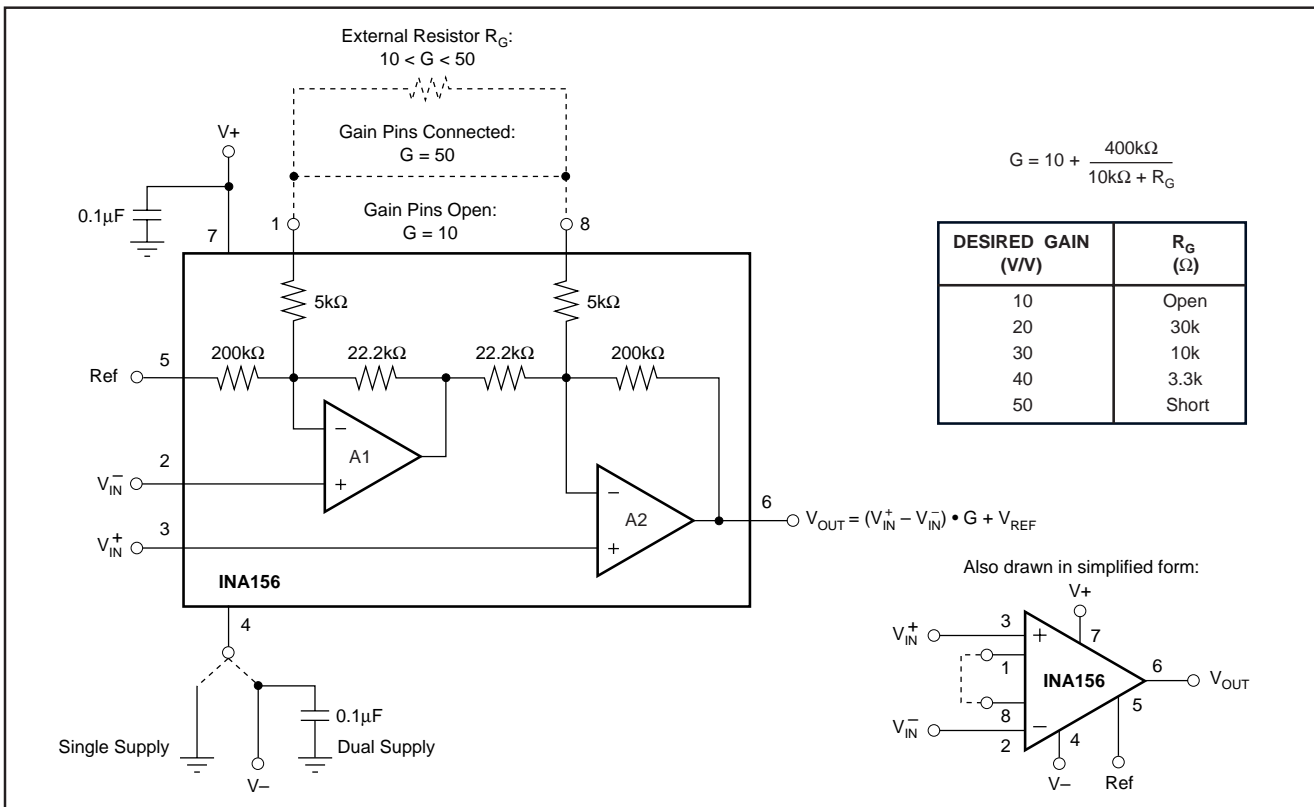

FIGURE 1. Basic Connections.

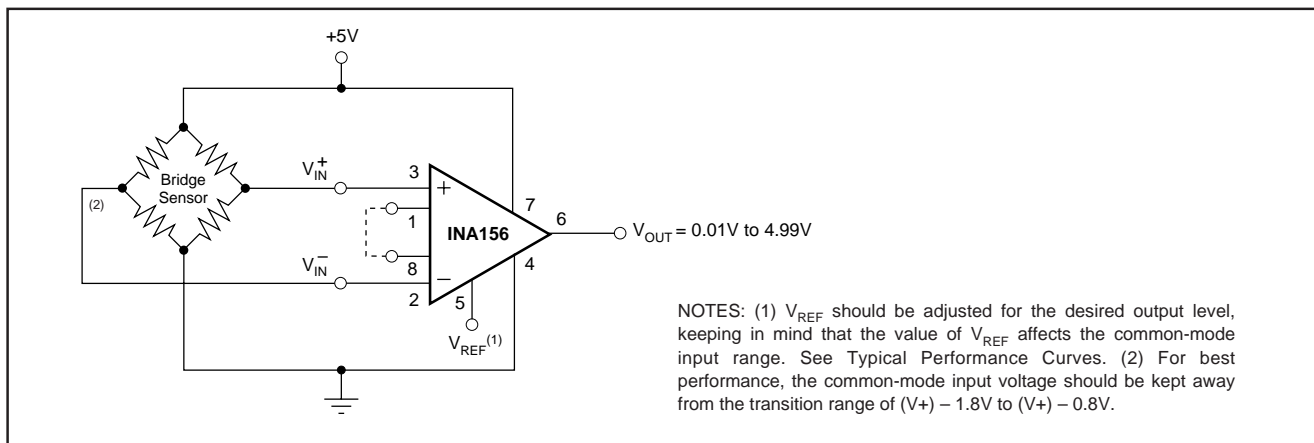

FIGURE 2. Single-Supply Bridge Amplifier.



## SETTING THE GAIN

Gain of 10 is achieved simply by leaving the two gain pins (1 and 8) open. Gain of 50 is achieved by connecting the gain pins together directly. In the  $G = 10$  configuration, the gain error is less than 0.4%. In the  $G = 50$  configuration, the gain error is less than 0.8%.

Gain can be set to any value between 10 and 50 by connecting a resistor  $R_G$  between the gain pins according to the following equation:

$$10 + 400k\Omega / (10k\Omega + R_G) \quad (1)$$

This is demonstrated in Figure 1 and is shown with the commonly used gains and resistor  $R_G$  values. However, because the absolute value of internal resistors is not guaranteed, using the INA156 in this configuration will increase the gain error and gain drift with temperature, as shown in Figure 3.

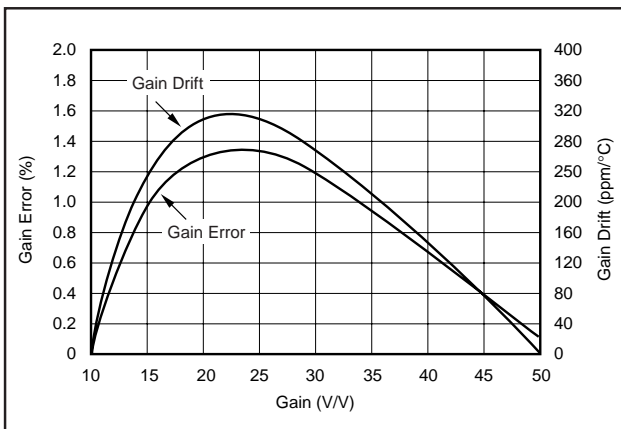

FIGURE 3. Typical Gain Error and Gain Error Drift with External Resistor.

## OFFSET TRIMMING

Offset voltage can be adjusted by applying a correction voltage to the reference terminal. Figure 4 shows an optional circuit for trimming the output offset voltage. The voltage applied to the Ref terminal is added to the output signal. An op amp buffer is used to provide low impedance at the Ref terminal to preserve good common-mode rejection.

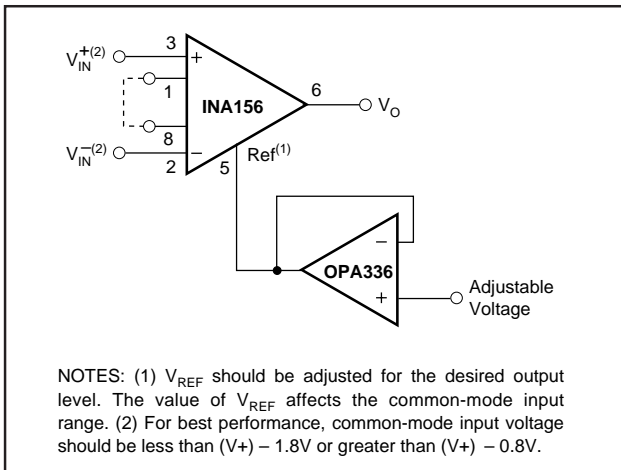

FIGURE 4. Optional Trimming of Output Offset Voltage.

## INPUT BIAS CURRENT RETURN

The input impedance of the INA156 is extremely high—approximately  $10^{13}\Omega$ , making it ideal for use with high-impedance sources. However, a path must be provided for the input bias current of both inputs. This input bias current is less than 10pA and is virtually independent of the input voltage.

Input circuitry must provide a path for this input bias current for proper operation. Figure 5 shows various provisions for an input bias current path. Without a bias current path, the inputs will float to a potential that exceeds the common-mode range and the input amplifier will saturate.

If the differential source resistance is low, the bias current return path can be connected to one input (see the thermocouple in Figure 5). With higher source impedance, using two equal resistors provides a balanced input with advantages of lower input offset voltage due to bias current and better high-frequency common-mode rejection.

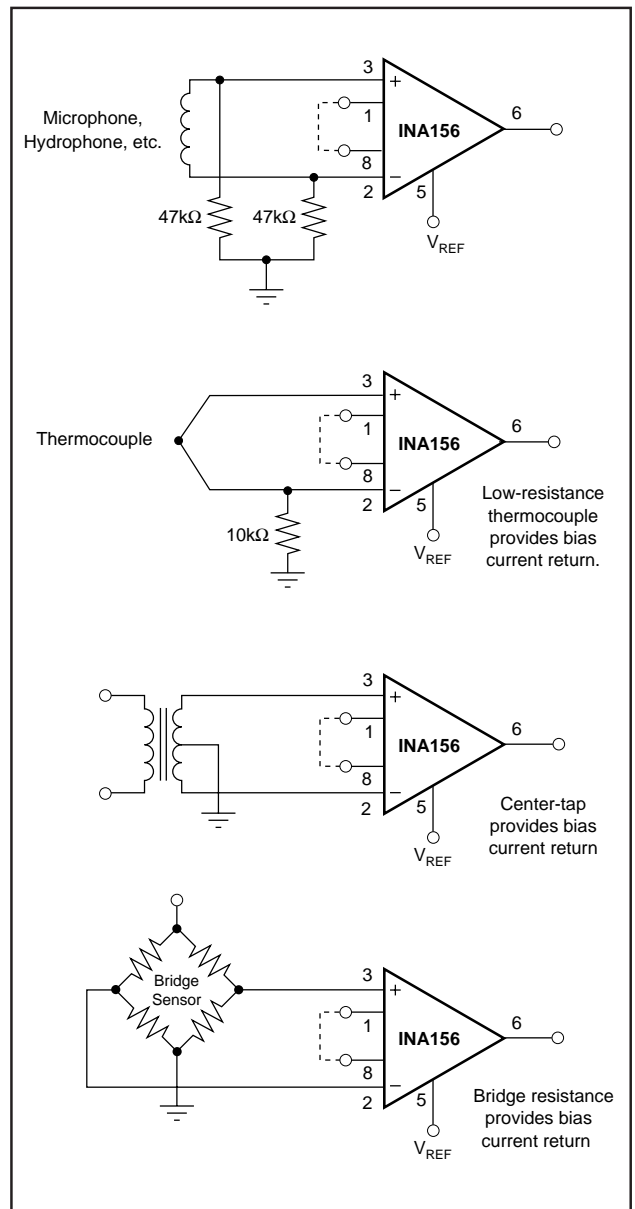

FIGURE 5. Providing an Input Common-Mode Current Path.

## INPUT COMMON-MODE RANGE

The input common-mode range of the INA156 for various operating conditions is shown in the Typical Performance Curves. The common-mode input range is limited by the output voltage swing of A1, an internal circuit node. For the  $G = 10$  configuration, output voltage of A1 can be expressed as:

$$V_{OUTA1} = -\frac{1}{9}V_{REF} + (1 + \frac{1}{9})V_{IN-} \quad (2)$$

The input common-mode voltage range can be calculated using this equation, given that the output of A1 can swing to within 20mV of either rail. When the input common-mode range is exceeded (A1's output is saturated), A2 can still be in linear operation and respond to changes in the non-inverting input voltage. However, the output voltage will be invalid.

The common-mode range for the  $G = 50$  configuration is included in the typical performance curve, "Input Common-Mode Range vs Output Voltage."

## INPUT RANGE FOR BEST ACCURACY

The internal amplifiers have rail-to-rail input stages, achieved by using complementary n-channel and p-channel input pairs. The common-mode input voltage determines whether the p-channel or the n-channel input stage is operating. The transition between the input stages is gradual and occurs between  $(V+) - 1.8V$  to  $(V+) - 1V$ . Due to these characteristics, operating the INA156 with input voltages within the transition region of  $(V+) - 1.8V$  to  $(V+) - 0.8V$  results in a shift in input offset voltage, and reduced common-mode and power supply rejection performance. Typical patterns of the offset voltage change throughout the input common-mode range are illustrated in Figure 6. The INA156 can be operated below or above the transition region with excellent results. Figure 7 demonstrates the use of the INA156 in a single-supply, high-side current monitor. In this application, the INA156 is operated above the transition region.

## RAIL-TO-RAIL OUTPUT

A class AB output stage with common-source transistors is used to achieve rail-to-rail output. For resistive loads greater than 10k $\Omega$ , the output voltage can swing to within a few millivolts of the supply rail while maintaining low gain error. For heavier loads and over temperature, see the typical performance curve "Output Voltage Swing vs Output Current." The INA156's low output impedance at high frequencies makes it suitable for directly driving Capacitive Digital-to-Analog (CDAC) input A/D converters, as shown in Figure 9.

## INPUT PROTECTION

Device inputs are protected by ESD diodes that will conduct if the input voltages exceed the power supplies by more than 500mV. Momentary voltages greater than 500mV beyond the power supply can be tolerated if the current on the input pins is limited to 10mA. This is easily accomplished with input resistors  $R_{LIM}$ , as shown in Figure 8. Many input signals are inherently current-limited to less than 10mA. Therefore, a limiting resistor is not required.

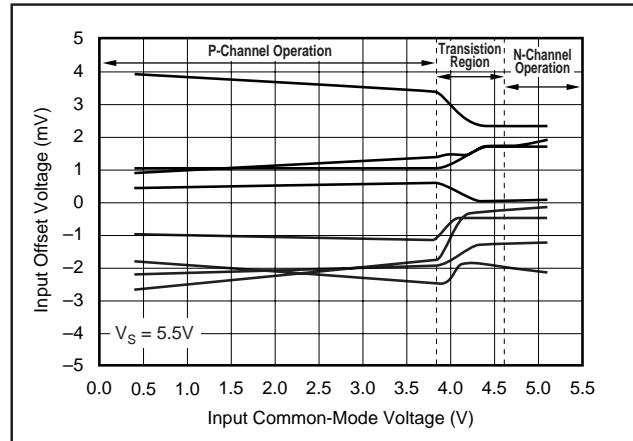

FIGURE 6. Input Offset Voltage Changes with Common-Mode Voltage.

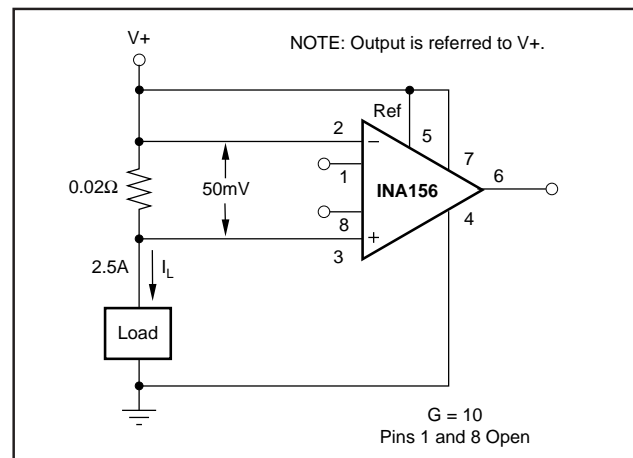

FIGURE 7. Single-Supply, High-Side Current Monitor.

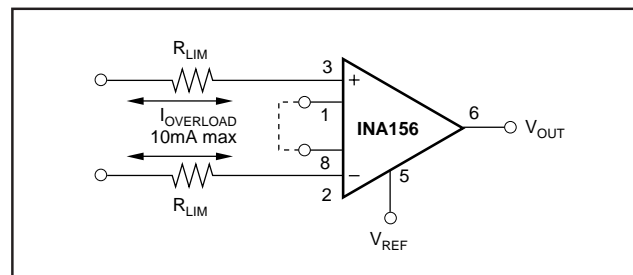

FIGURE 8. Input Current Protection for Voltages Exceeding the Supply Voltage.

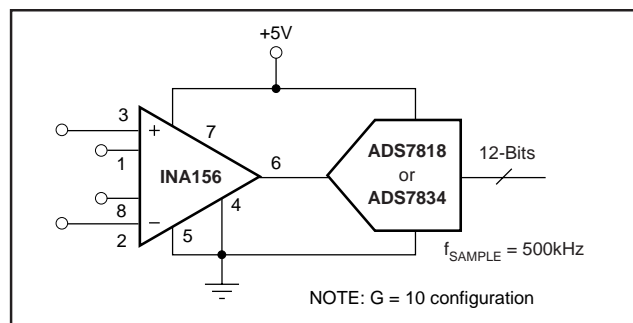

FIGURE 9. Driving Capacitive-Input A/D Converter.