

**OPA227**  
**OPA2227**  
**OPA4227**  
**OPA228**  
**OPA2228**  
**OPA4228**

For most current data sheet and other product information, visit [www.burr-brown.com](http://www.burr-brown.com)

## High Precision, Low Noise OPERATIONAL AMPLIFIERS

### FEATURES

- **LOW NOISE:**  $3\text{nV}/\sqrt{\text{Hz}}$
- **WIDE BANDWIDTH:**  
 OPA227: 8MHz,  $2.3\text{V}/\mu\text{s}$   
 OPA228: 33MHz,  $10\text{V}/\mu\text{s}$
- **SETTLING TIME:**  $5\mu\text{s}$   
 (significant improvement over OP-27)
- **HIGH CMRR:** 138dB
- **HIGH OPEN-LOOP GAIN:** 160dB
- **LOW INPUT BIAS CURRENT:** 10nA max
- **LOW OFFSET VOLTAGE:**  $75\mu\text{V}$  max
- **WIDE SUPPLY RANGE:**  $\pm 2.5\text{V}$  to  $\pm 18\text{V}$
- **OPA227 REPLACES OP-27, LT1007, MAX427**
- **OPA228 REPLACES OP-37, LT1037, MAX437**
- **SINGLE, DUAL, AND QUAD VERSIONS**

### APPLICATIONS

- DATA ACQUISITION
- TELECOM EQUIPMENT
- GEOPHYSICAL ANALYSIS
- VIBRATION ANALYSIS
- SPECTRAL ANALYSIS
- PROFESSIONAL AUDIO EQUIPMENT
- ACTIVE FILTERS
- POWER SUPPLY CONTROL

### DESCRIPTION

The OPA227 and OPA228 series op amps combine low noise and wide bandwidth with high precision to make them the ideal choice for applications requiring both ac and precision dc performance.

The OPA227 is unity gain stable and features high slew rate ( $2.3\text{V}/\mu\text{s}$ ) and wide bandwidth (8MHz). The OPA228 is optimized for closed-loop gains of 5 or greater, and offers higher speed with a slew rate of  $10\text{V}/\mu\text{s}$  and a bandwidth of 33MHz.

The OPA227 and OPA228 series op amps are ideal for professional audio equipment. In addition, low quiescent current and low cost make them ideal for portable applications requiring high precision.

The OPA227 and OPA228 series op amps are pin-for-pin replacements for the industry standard OP-27 and OP-37 with substantial improvements across the board. The dual and quad versions are available for space savings and per-channel cost reduction.

The OPA227, OPA228, OPA2227, and OPA2228 are available in DIP-8 and SO-8 packages. The OPA4227 and OPA4228 are available in DIP-14 and SO-14 packages with standard pin configurations. Operation is specified from  $-40^\circ\text{C}$  to  $+85^\circ\text{C}$ .

SPICE Model available for OPA227 at [www.burr-brown.com](http://www.burr-brown.com)

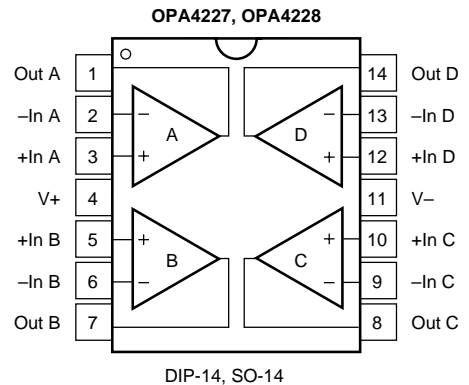
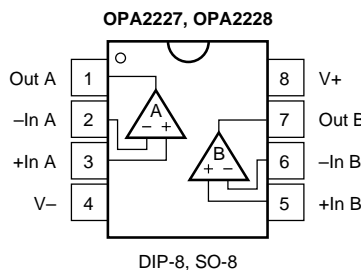
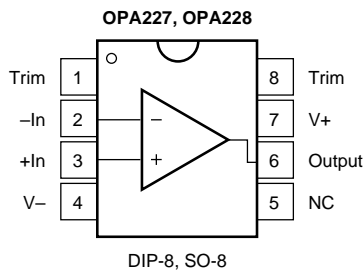

International Airport Industrial Park • Mailing Address: PO Box 11400, Tucson, AZ 85734 • Street Address: 6730 S. Tucson Blvd., Tucson, AZ 85706 • Tel: (520) 746-1111  
 Twx: 910-952-1111 • Internet: <http://www.burr-brown.com/> • Cable: BBRCORP • Telex: 066-6491 • FAX: (520) 889-1510 • Immediate Product Info: (800) 548-6132

# SPECIFICATIONS: $V_S = \pm 5V$ to $\pm 15V$

## OPA227 Series

At  $T_A = +25^\circ C$ , and  $R_L = 10k\Omega$ , unless otherwise noted.

**Boldface** limits apply over the specified temperature range,  $T_A = -40^\circ C$  to  $+85^\circ C$ .

| PARAMETER   | CONDITION  | OPA227P, U<br>OPA2227P, U  |  |  | OPA227PA, UA<br>OPA2227PA, UA<br>OPA4227PA, UA |   |  | UNITS  |
|---|--|--|--|--|--|---|--|--|
|   |  | MIN  | TYP  | MAX  | MIN  | TYP   | MAX  |  |
| <b>OFFSET VOLTAGE</b><br>Input Offset Voltage $V_{OS}$<br>$T_A = -40^\circ C$ to $+85^\circ C$<br>vs Temperature $dV_{OS}/dT$<br>vs Power Supply PSRR<br>$T_A = -40^\circ C$ to $+85^\circ C$<br>vs Time<br>Channel Separation (dual, quad) | $V_S = \pm 2.5V$ to $\pm 18V$<br><br>dc<br>$f = 1kHz, R_L = 5k\Omega$  |  | $\pm 5$<br><br><b><math>\pm 0.1</math></b><br>$\pm 0.5$<br><br>0.2<br>0.2<br>110 | $\pm 75$<br><b><math>\pm 100</math></b><br><b><math>\pm 0.6</math></b><br>$\pm 2$<br><b><math>\pm 2</math></b> |  | $\pm 10$<br><br><b><math>\pm 0.3</math></b><br><br>*<br>*<br>*<br>* | $\pm 200$<br><b><math>\pm 200</math></b><br><b><math>\pm 2</math></b><br>*<br>*<br>* | $\mu V$<br>$\mu V$<br>$\mu V/^\circ C$<br>$\mu V/V$<br>$\mu V/V$<br>$\mu V/mo$<br>$\mu V/V$<br>dB      |
| <b>INPUT BIAS CURRENT</b><br>Input Bias Current $I_B$<br>$T_A = -40^\circ C$ to $+85^\circ C$<br>Input Offset Current $I_{OS}$<br>$T_A = -40^\circ C$ to $+85^\circ C$  |  |  | $\pm 2.5$<br><br>$\pm 2.5$   | $\pm 10$<br><b><math>\pm 10</math></b><br>$\pm 10$<br><b><math>\pm 10</math></b>                               |  | *<br>*<br>*<br>*  | *<br>*<br>*<br>*   | nA<br>nA<br>nA<br>nA   |
| <b>NOISE</b><br>Input Voltage Noise, $f = 0.1Hz$ to $10Hz$<br><br>Input Voltage Noise Density, $f = 10Hz$ $e_n$<br>$f = 100Hz$<br>$f = 1kHz$<br>Current Noise Density, $f = 1kHz$ $i_n$   |  |  | 90<br>15<br>3.5<br>3<br>3<br>0.4   |  |  | *<br>*<br>*<br>*<br>*<br>*  |  | nVp-p<br>nVrms<br>nV/ $\sqrt{Hz}$<br>nV/ $\sqrt{Hz}$<br>nV/ $\sqrt{Hz}$<br>pA/ $\sqrt{Hz}$             |
| <b>INPUT VOLTAGE RANGE</b><br>Common-Mode Voltage Range $V_{CM}$<br>Common-Mode Rejection CMRR<br>$T_A = -40^\circ C$ to $+85^\circ C$  | $V_{CM} = (V-)+2V$ to $(V+)-2V$  | $(V-)+2$<br>120<br><b>120</b>  | 138  | $(V+)-2$   | *<br>*<br>*                                    | *<br>*<br>*   | *<br>*<br>*  | V<br>dB<br>dB  |
| <b>INPUT IMPEDANCE</b><br>Differential<br>Common-Mode   | $V_{CM} = (V-)+2V$ to $(V+)-2V$  |  | $10^7 \parallel 12$<br>$10^9 \parallel 3$  |  |  | *<br>*  |  | $\Omega \parallel pF$<br>$\Omega \parallel pF$   |
| <b>OPEN-LOOP GAIN</b><br>Open-Loop Voltage Gain $A_{OL}$<br>$T_A = -40^\circ C$ to $+85^\circ C$<br><br>$T_A = -40^\circ C$ to $+85^\circ C$  | $V_O = (V-)+2V$ to $(V+)-2V, R_L = 10k\Omega$<br><br>$V_O = (V-)+3.5V$ to $(V+)-3.5V, R_L = 600\Omega$                             | 132<br><b>132</b><br>132<br><b>132</b>   | 160<br><br>160   |  | *<br>*<br>*<br>*                               | *<br>*<br>*<br>*  |  | dB<br>dB<br>dB<br>dB   |
| <b>FREQUENCY RESPONSE</b><br>Gain Bandwidth Product GBW<br>Slew Rate SR<br>Settling Time: 0.1%<br>0.01%<br>Overload Recovery Time<br>Total Harmonic Distortion + Noise THD+N  | $G = 1, 10V$ Step, $C_L = 100pF$<br>$G = 1, 10V$ Step, $C_L = 100pF$<br>$V_{IN} \cdot G = V_S$<br>$f = 1kHz, G = 1, V_O = 3.5Vrms$ |  | 8<br>2.3<br>5<br>5.6<br>1.3<br>0.00005   |  |  | *<br>*<br>*<br>*<br>*<br>*  |  | MHz<br>V/ $\mu s$<br>$\mu s$<br>$\mu s$<br>$\mu s$<br>%  |
| <b>OUTPUT</b><br>Voltage Output<br>$T_A = -40^\circ C$ to $+85^\circ C$<br><br>$T_A = -40^\circ C$ to $+85^\circ C$<br>Short-Circuit Current $I_{SC}$<br>Capacitive Load Drive $C_{LOAD}$   | $R_L = 10k\Omega$<br>$R_L = 10k\Omega$<br>$R_L = 600\Omega$<br>$R_L = 600\Omega$   | $(V-)+2$<br><b><math>(V-)+2</math></b><br>$(V-)+3.5$<br><b><math>(V-)+3.5</math></b> | $\pm 45$<br>See Typical Curve  | $(V+)-2$<br><b><math>(V+)-2</math></b><br>$(V+)-3.5$<br><b><math>(V+)-3.5</math></b>                           | *<br>*<br>*<br>*                               | *<br>*<br>*<br>*  | *<br>*<br>*<br>*   | V<br>V<br>V<br>V<br>mA   |
| <b>POWER SUPPLY</b><br>Specified Voltage Range $V_S$<br>Operating Voltage Range<br>Quiescent Current (per amplifier) $I_Q$<br>$T_A = -40^\circ C$ to $+85^\circ C$  | $I_Q = 0$<br>$I_Q = 0$   | $\pm 5$<br>$\pm 2.5$   | $\pm 3.7$  | $\pm 15$<br>$\pm 18$<br>$\pm 3.8$<br><b><math>\pm 4.2</math></b>   | *<br>*<br>*<br>*                               | *<br>*<br>*<br>*  | *<br>*<br>*<br>*   | V<br>V<br>mA<br>mA   |
| <b>TEMPERATURE RANGE</b><br>Specified Range<br>Operating Range<br>Storage Range<br>Thermal Resistance $\theta_{JA}$<br>SO-8 Surface Mount<br>DIP-8<br>DIP-14<br>SO-14 Surface Mount   |  | -40<br>-55<br>-65  |  | +85<br>+125<br>+150  | *<br>*<br>*                                    | *<br>*<br>*   | *<br>*<br>*  | $^\circ C$<br>$^\circ C$<br>$^\circ C$<br>$^\circ C/W$<br>$^\circ C/W$<br>$^\circ C/W$<br>$^\circ C/W$ |

\* Specifications same as OPA227P, U.

# SPECIFICATIONS: $V_S = \pm 5V$ to $\pm 15V$

## OPA228 Series

At  $T_A = +25^\circ\text{C}$ , and  $R_L = 10\text{k}\Omega$ , unless otherwise noted.

**Boldface** limits apply over the specified temperature range,  $T_A = -40^\circ\text{C}$  to  $+85^\circ\text{C}$ .

| PARAMETER   | CONDITION  | OPA228P, U<br>OPA2228P, U    |                     |                              | OPA228PA, UA<br>OPA2228PA, UA<br>OPA4228PA, UA |           |                              | UNITS                        |
|---|--|------------------------------|---------------------|------------------------------|--|-----------|------------------------------|------------------------------|
|   |  | MIN                          | TYP                 | MAX                          | MIN  | TYP       | MAX                          |                              |
| <b>OFFSET VOLTAGE</b><br>Input Offset Voltage $V_{OS}$<br>$T_A = -40^\circ\text{C}$ to $+85^\circ\text{C}$<br>vs Temperature $dV_{OS}/dT$<br>vs Power Supply PSRR<br>$T_A = -40^\circ\text{C}$ to $+85^\circ\text{C}$<br>vs Time<br>Channel Separation (dual, quad) | $V_S = \pm 2.5V$ to $\pm 18V$<br><br>dc<br>$f = 1\text{kHz}$ , $R_L = 5\text{k}\Omega$   |                              | $\pm 5$             | $\pm 75$                     |  | $\pm 10$  | $\pm 200$                    | $\mu\text{V}$                |
|   |  |                              | $\pm 0.1$           | $\pm 0.6$                    |  | $\pm 0.3$ | $\pm 2$                      | $\mu\text{V}/^\circ\text{C}$ |
|   |  |                              | $\pm 0.5$           | $\pm 2$                      |  | *         | *                            | $\mu\text{V}/V$              |
|   |  |                              | 0.2                 |                              |  | *         | *                            | $\mu\text{V}/\text{mo}$      |
|   |  | 0.2                          |                     |                              | *  | *         | $\mu\text{V}/V$              |                              |
|   |  | 110                          |                     |                              | *  | *         | dB                           |                              |
| <b>INPUT BIAS CURRENT</b><br>Input Bias Current $I_B$<br>$T_A = -40^\circ\text{C}$ to $+85^\circ\text{C}$<br>Input Offset Current $I_{OS}$<br>$T_A = -40^\circ\text{C}$ to $+85^\circ\text{C}$  |  |                              | $\pm 2.5$           | $\pm 10$                     |  | *         | *                            | nA                           |
|   |  |                              |                     | $\pm 10$                     |  | *         | *                            | nA                           |
|   |  |                              | $\pm 2.5$           | $\pm 10$                     |  | *         | *                            | nA                           |
|   |  |                              |                     | $\pm 10$                     |  | *         | *                            | nA                           |
| <b>NOISE</b><br>Input Voltage Noise, $f = 0.1\text{Hz}$ to $10\text{Hz}$<br><br>Input Voltage Noise Density, $f = 10\text{Hz}$ $e_n$<br>$f = 100\text{Hz}$<br>$f = 1\text{kHz}$<br>Current Noise Density, $f = 1\text{kHz}$ $i_n$                                   |  |                              | 90                  |                              |  | *         | *                            | nVp-p                        |
|   |  |                              | 15                  |                              |  | *         | *                            | nVrms                        |
|   |  |                              | 3.5                 |                              |  | *         | *                            | $\text{nV}/\sqrt{\text{Hz}}$ |
|   |  |                              | 3                   |                              |  | *         | *                            | $\text{nV}/\sqrt{\text{Hz}}$ |
|   |  |                              | 3                   |                              |  | *         | *                            | $\text{nV}/\sqrt{\text{Hz}}$ |
|   |  | 0.4                          |                     |                              | *  | *         | $\text{pA}/\sqrt{\text{Hz}}$ |                              |
| <b>INPUT VOLTAGE RANGE</b><br>Common-Mode Voltage Range $V_{CM}$<br>Common-Mode Rejection CMRR<br>$T_A = -40^\circ\text{C}$ to $+85^\circ\text{C}$  | $V_{CM} = (V-)+2V$ to $(V+)-2V$  | $(V-)+2$                     |                     | $(V+)-2$                     | *  |           | *                            | V                            |
|   |  | 120                          | 138                 |                              | *  | *         |                              | dB                           |
|   |  | <b>120</b>                   |                     |                              | *  |           |                              | dB                           |
| <b>INPUT IMPEDANCE</b><br>Differential<br>Common-Mode   | $V_{CM} = (V-)+2V$ to $(V+)-2V$  |                              | $10^7 \parallel 12$ |                              |  | *         |                              | $\Omega \parallel \text{pF}$ |
|   |  |                              | $10^9 \parallel 3$  |                              |  | *         |                              | $\Omega \parallel \text{pF}$ |
| <b>OPEN-LOOP GAIN</b><br>Open-Loop Voltage Gain $A_{OL}$<br>$T_A = -40^\circ\text{C}$ to $+85^\circ\text{C}$<br><br>$T_A = -40^\circ\text{C}$ to $+85^\circ\text{C}$  | $V_O = (V-)+2V$ to $(V+)-2V$ , $R_L = 10\text{k}\Omega$<br><br>$V_O = (V-)+3.5V$ to $(V+)-3.5V$ , $R_L = 600\Omega$  | 132                          | 160                 |                              | *  | *         |                              | dB                           |
|   |  | <b>132</b>                   |                     |                              | *  | *         |                              | dB                           |
|   |  | 132                          | 160                 |                              | *  | *         |                              | dB                           |
|   |  | <b>132</b>                   |                     |                              | *  | *         |                              | dB                           |
| <b>FREQUENCY RESPONSE</b><br>Minimum Closed-Loop Gain<br>Gain Bandwidth Product GBW<br>Slew Rate SR<br>Settling Time: 0.1%<br>0.01%<br>Overload Recovery Time<br>Total Harmonic Distortion + Noise THD+N  | $G = 5$ , 10V Step, $C_L = 100\text{pF}$ , $C_F = 12\text{pF}$<br>$G = 5$ , 10V Step, $C_L = 100\text{pF}$ , $C_F = 12\text{pF}$<br>$V_{IN} \cdot G = V_S$<br>$f = 1\text{kHz}$ , $G = 5$ , $V_O = 3.5V_{rms}$ |                              | 5                   |                              |  | *         |                              | V/V                          |
|   |  |                              | 33                  |                              |  | *         |                              | MHz                          |
|   |  |                              | 11                  |                              |  | *         |                              | V/ $\mu\text{s}$             |
|   |  |                              | 1.5                 |                              |  | *         |                              | $\mu\text{s}$                |
|   |  |                              | 2                   |                              |  | *         |                              | $\mu\text{s}$                |
|   |  |                              | 0.6                 |                              |  | *         |                              | $\mu\text{s}$                |
|   |  |                              | 0.00005             |                              |  | *         |                              | %                            |
| <b>OUTPUT</b><br>Voltage Output<br>$T_A = -40^\circ\text{C}$ to $+85^\circ\text{C}$<br><br>$T_A = -40^\circ\text{C}$ to $+85^\circ\text{C}$<br>Short-Circuit Current $I_{SC}$<br>Capacitive Load Drive $C_{LOAD}$   | $R_L = 10\text{k}\Omega$<br>$R_L = 10\text{k}\Omega$<br>$R_L = 600\Omega$<br>$R_L = 600\Omega$   | $(V-)+2$                     |                     | $(V+)-2$                     | *  |           | *                            | V                            |
|   |  | <b><math>(V-)+2</math></b>   |                     | <b><math>(V+)-2</math></b>   | *  |           | *                            | V                            |
|   |  | $(V-)+3.5$                   |                     | $(V+)-3.5$                   | *  |           | *                            | V                            |
|   |  | <b><math>(V-)+3.5</math></b> |                     | <b><math>(V+)-3.5</math></b> | *  |           | *                            | V                            |
|   |  | $\pm 45$                     |                     |                              | *  | *         |                              | mA                           |
|   |  | See Typical Curve            |                     |                              |  | *         |                              |                              |
| <b>POWER SUPPLY</b><br>Specified Voltage Range $V_S$<br>Operating Voltage Range<br>Quiescent Current (per amplifier) $I_Q$<br>$T_A = -40^\circ\text{C}$ to $+85^\circ\text{C}$  | $I_O = 0$<br>$I_O = 0$   | $\pm 5$                      |                     | $\pm 15$                     | *  |           | *                            | V                            |
|   |  | $\pm 2.5$                    |                     | $\pm 18$                     | *  |           | *                            | V                            |
|   |  | $\pm 3.7$                    |                     | $\pm 3.8$                    |  | *         | *                            | mA                           |
|   |  |                              |                     | <b><math>\pm 4.2</math></b>  |  | *         | mA                           |                              |
| <b>TEMPERATURE RANGE</b><br>Specified Range<br>Operating Range<br>Storage Range<br>Thermal Resistance $\theta_{JA}$<br>SO-8 Surface Mount<br>DIP-8<br>DIP-14<br>SO-14 Surface Mount   |  | -40                          |                     | +85                          | *  |           | *                            | $^\circ\text{C}$             |
|   |  | -55                          |                     | +125                         | *  |           | *                            | $^\circ\text{C}$             |
|   |  | -65                          |                     | +150                         | *  |           | *                            | $^\circ\text{C}$             |
|   |  |                              | 150                 |                              |  | *         |                              | $^\circ\text{C}/\text{W}$    |
|   |  |                              | 100                 |                              |  | *         |                              | $^\circ\text{C}/\text{W}$    |
|   |  |                              | 80                  |                              |  | *         |                              | $^\circ\text{C}/\text{W}$    |
|   |  |                              | 100                 |                              |  | *         |                              | $^\circ\text{C}/\text{W}$    |

\* Specifications same as OPA228P, U.

## ABSOLUTE MAXIMUM RATINGS<sup>(1)</sup>

|   |                          |
|---|--------------------------|
| Supply Voltage .....                      | ±18V                     |
| Signal Input Terminals, Voltage .....     | (V-) -0.7V to (V+) +0.7V |
| Current .....                             | 20mA                     |
| Output Short-Circuit <sup>(2)</sup> ..... | Continuous               |
| Operating Temperature .....               | -55°C to +125°C          |
| Storage Temperature .....                 | -65°C to +150°C          |
| Junction Temperature .....                | 150°C                    |
| Lead Temperature (soldering, 10s) .....   | 300°C                    |

NOTE: (1) Stresses above these ratings may cause permanent damage. Exposure to absolute maximum conditions for extended periods may degrade device reliability. (2) Short-circuit to ground, one amplifier per package.



## ELECTROSTATIC DISCHARGE SENSITIVITY

This integrated circuit can be damaged by ESD. Burr-Brown recommends that all integrated circuits be handled with appropriate precautions. Failure to observe proper handling and installation procedures can cause damage.

ESD damage can range from subtle performance degradation to complete device failure. Precision integrated circuits may be more susceptible to damage because very small parametric changes could cause the device not to meet its published specifications.

## PACKAGE/ORDERING INFORMATION

| PRODUCT              | OFFSET VOLTAGE max, $\mu\text{V}$ | OFFSET VOLTAGE DRIFT max, $\mu\text{V}/^\circ\text{C}$ | PACKAGE             | PACKAGE DRAWING NUMBER <sup>(1)</sup> | TEMPERATURE RANGE | ORDERING NUMBER <sup>(2)</sup> | TRANSPORT MEDIA |
|----------------------|-----------------------------------|--|---------------------|---------------------------------------|-------------------|--------------------------------|-----------------|
| <b>OPA227 Series</b> |                                   |  |                     |                                       |                   |                                |                 |
| <b>Single</b>        |                                   |  |                     |                                       |                   |                                |                 |
| OPA227PA             | ±200                              | ±2   | DIP-8               | 006                                   | -40°C to +85°C    | OPA227PA                       | Rails           |
| OPA227P              | ±75                               | ±0.6   | DIP-8               | 006                                   | -40°C to +85°C    | OPA227P                        | Rails           |
| OPA227UA             | ±200                              | ±2   | SO-8 Surface Mount  | 182                                   | -40°C to +85°C    | OPA227UA                       | Rails           |
| "                    | "                                 | "  | "                   | "                                     | "                 | OPA227UA/2K5                   | Tape and Reel   |
| OPA227U              | ±75                               | ±0.6   | SO-8 Surface Mount  | 182                                   | -40°C to +85°C    | OPA227U                        | Rails           |
| "                    | "                                 | "  | "                   | "                                     | "                 | OPA227U/2K5                    | Tape and Reel   |
| <b>Dual</b>          |                                   |  |                     |                                       |                   |                                |                 |
| OPA2227PA            | ±200                              | ±2   | DIP-8               | 006                                   | -40°C to +85°C    | OPA2227PA                      | Rails           |
| OPA2227P             | ±75                               | ±0.6   | DIP-8               | 006                                   | -40°C to +85°C    | OPA2227P                       | Rails           |
| OPA2227UA            | ±200                              | ±2   | SO-8 Surface Mount  | 182                                   | -40°C to +85°C    | OPA2227UA                      | Rails           |
| "                    | "                                 | "  | "                   | "                                     | "                 | OPA2227UA/2K5                  | Tape and Reel   |
| OPA2227U             | ±75                               | ±0.6   | SO-8 Surface Mount  | 182                                   | -40°C to +85°C    | OPA2227U                       | Rails           |
| "                    | "                                 | "  | "                   | "                                     | "                 | OPA2227U/2K5                   | Tape and Reel   |
| <b>Quad</b>          |                                   |  |                     |                                       |                   |                                |                 |
| OPA4227PA            | ±200                              | ±2   | DIP-14              | 010                                   | -40°C to +85°C    | OPA4227PA                      | Rails           |
| OPA4227UA            | ±200                              | ±2   | SO-14 Surface Mount | 235                                   | -40°C to +85°C    | OPA4227UA                      | Rails           |
| "                    | "                                 | "  | "                   | "                                     | "                 | OPA4227UA/2K5                  | Tape and Reel   |
| <b>OPA228 Series</b> |                                   |  |                     |                                       |                   |                                |                 |
| <b>Single</b>        |                                   |  |                     |                                       |                   |                                |                 |
| OPA228PA             | ±200                              | ±2   | DIP-8               | 006                                   | -40°C to +85°C    | OPA228PA                       | Rails           |
| OPA228P              | ±75                               | ±0.6   | DIP-8               | 006                                   | -40°C to +85°C    | OPA228P                        | Rails           |
| OPA228UA             | ±200                              | ±2   | SO-8 Surface Mount  | 182                                   | -40°C to +85°C    | OPA228UA                       | Rails           |
| "                    | "                                 | "  | "                   | "                                     | "                 | OPA228UA/2K5                   | Tape and Reel   |
| OPA228U              | ±75                               | ±0.6   | SO-8 Surface Mount  | 182                                   | -40°C to +85°C    | OPA228U                        | Rails           |
| "                    | "                                 | "  | "                   | "                                     | "                 | OPA228U/2K5                    | Tape and Reel   |
| <b>Dual</b>          |                                   |  |                     |                                       |                   |                                |                 |
| OPA2228PA            | ±200                              | ±2   | DIP-8               | 006                                   | -40°C to +85°C    | OPA2228PA                      | Rails           |
| OPA2228P             | ±75                               | ±0.6   | DIP-8               | 006                                   | -40°C to +85°C    | OPA2228P                       | Rails           |
| OPA2228UA            | ±200                              | ±2   | SO-8 Surface Mount  | 182                                   | -40°C to +85°C    | OPA2228UA                      | Rails           |
| "                    | "                                 | "  | "                   | "                                     | "                 | OPA2228UA/2K5                  | Tape and Reel   |
| OPA2228U             | ±75                               | ±0.6   | SO-8 Surface Mount  | 182                                   | -40°C to +85°C    | OPA2228U                       | Rails           |
| "                    | "                                 | "  | "                   | "                                     | "                 | OPA2228U/2K5                   | Tape and Reel   |
| <b>Quad</b>          |                                   |  |                     |                                       |                   |                                |                 |
| OPA4228PA            | ±200                              | ±2   | DIP-14              | 010                                   | -40°C to +85°C    | OPA4228PA                      | Rails           |
| OPA4228UA            | ±200                              | ±2   | SO-14 Surface Mount | 235                                   | -40°C to +85°C    | OPA4228UA                      | Rails           |
| "                    | "                                 | "  | "                   | "                                     | "                 | OPA4228UA/2K5                  | Tape and Reel   |

NOTE: (1) For detailed drawing and dimension table, please see end of data sheet, or Appendix C of Burr-Brown IC Data Book. (2) Products followed by a slash (/) are only available in Tape and Reel in the quantities indicated (e.g. /2K5 indicates 2500 devices per reel). Ordering 2500 pieces of "OPA227UA/2K5" will get a single 2500 piece Tape and Reel. For detailed Tape and Reel mechanical information, refer to Appendix B of Burr-Brown IC Data Book.

The information provided herein is believed to be reliable; however, BURR-BROWN assumes no responsibility for inaccuracies or omissions. BURR-BROWN assumes no responsibility for the use of this information, and all use of such information shall be entirely at the user's own risk. Prices and specifications are subject to change without notice. No patent rights or licenses to any of the circuits described herein are implied or granted to any third party. BURR-BROWN does not authorize or warrant any BURR-BROWN product for use in life support devices and/or systems.

# TYPICAL PERFORMANCE CURVES

At  $T_A = +25^\circ\text{C}$ ,  $R_L = 10\text{k}\Omega$ , and  $V_S = \pm 15\text{V}$ , unless otherwise noted.

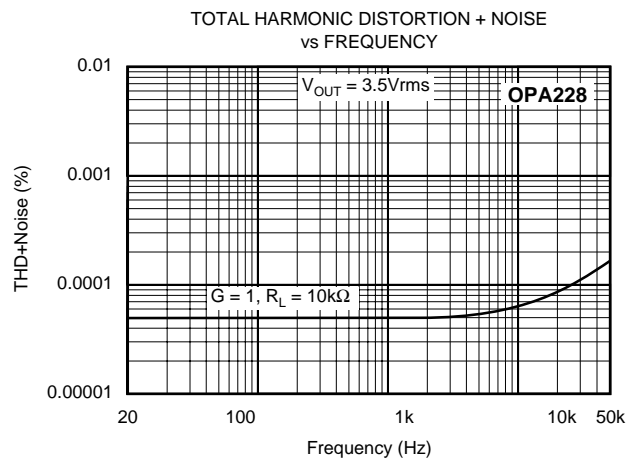
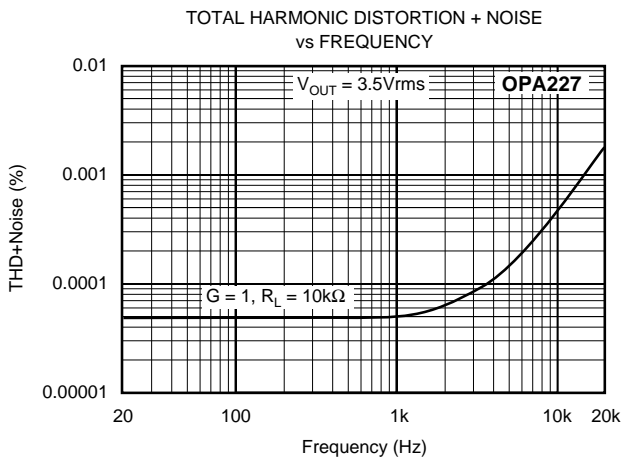
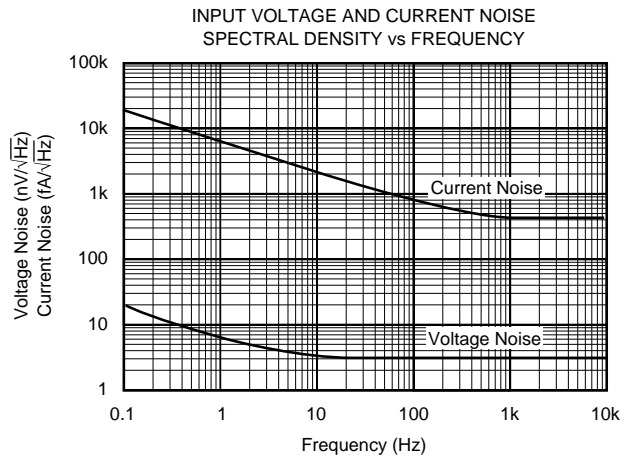
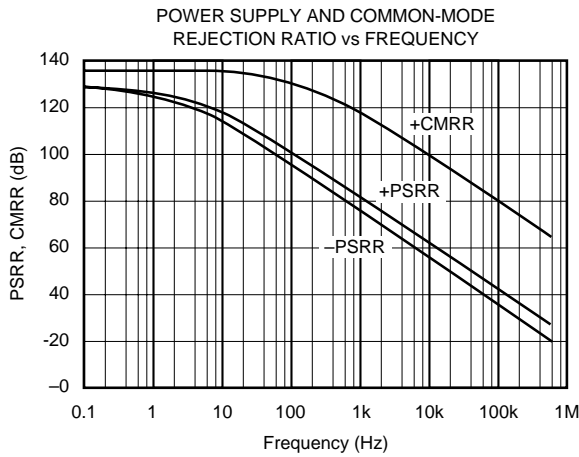
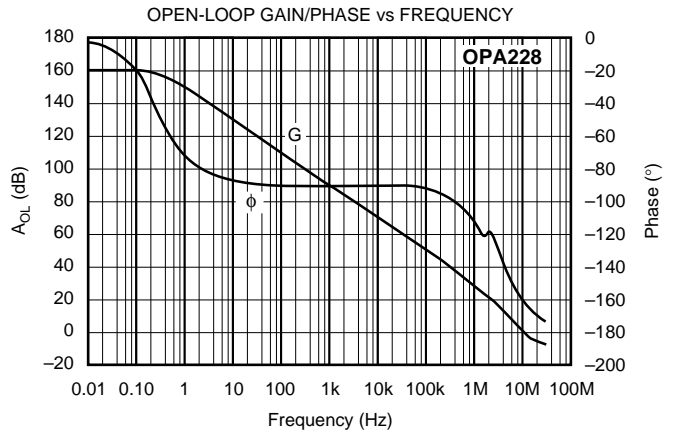
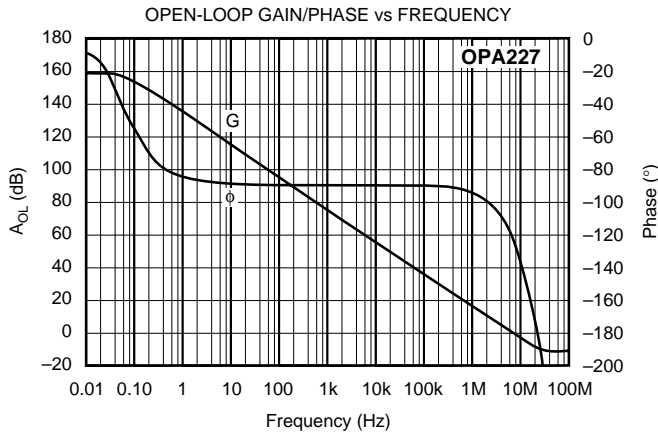

# TYPICAL PERFORMANCE CURVES (CONT)

At  $T_A = +25^\circ\text{C}$ ,  $R_L = 10\text{k}\Omega$ , and  $V_S = \pm 15\text{V}$ , unless otherwise noted.

INPUT NOISE VOLTAGE vs TIME

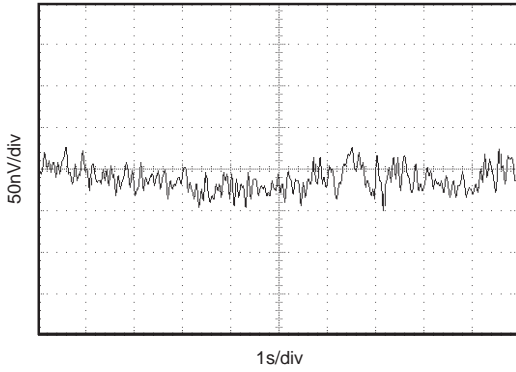

CHANNEL SEPARATION vs FREQUENCY

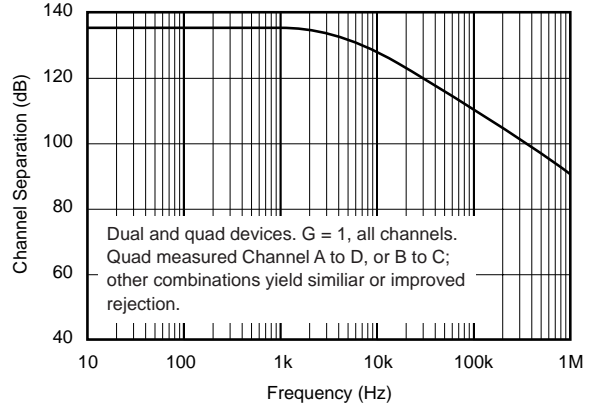

VOLTAGE NOISE DISTRIBUTION (10Hz)

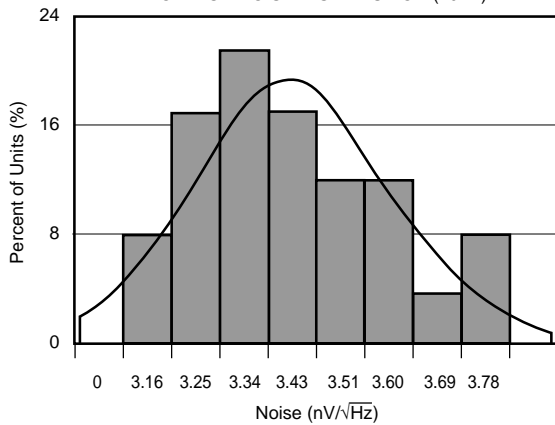

OFFSET VOLTAGE PRODUCTION DISTRIBUTION

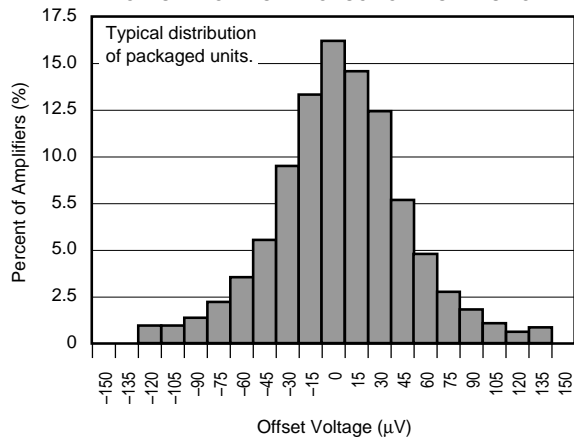

OFFSET VOLTAGE DRIFT PRODUCTION DISTRIBUTION

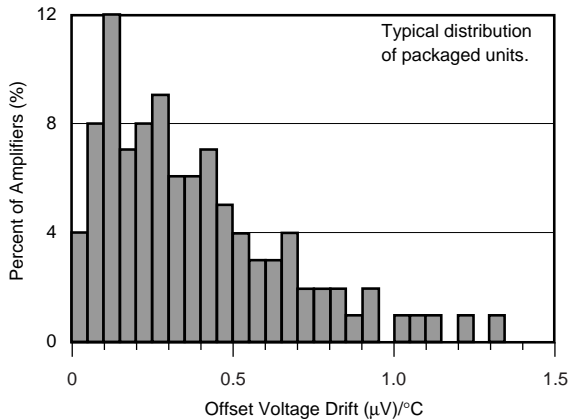

WARM-UP OFFSET VOLTAGE DRIFT

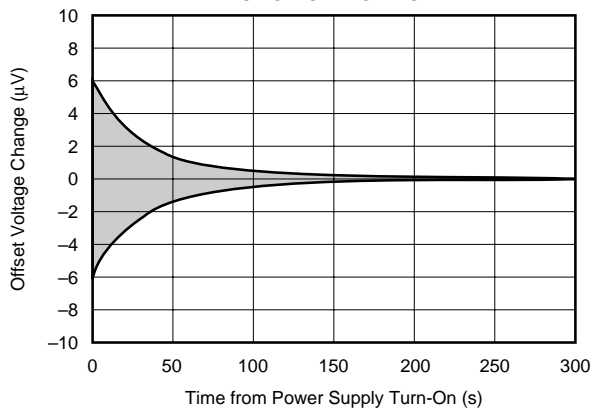

# TYPICAL PERFORMANCE CURVES (CONT)

At  $T_A = +25^\circ\text{C}$ ,  $R_L = 10\text{k}\Omega$ , and  $V_S = \pm 15\text{V}$ , unless otherwise noted.

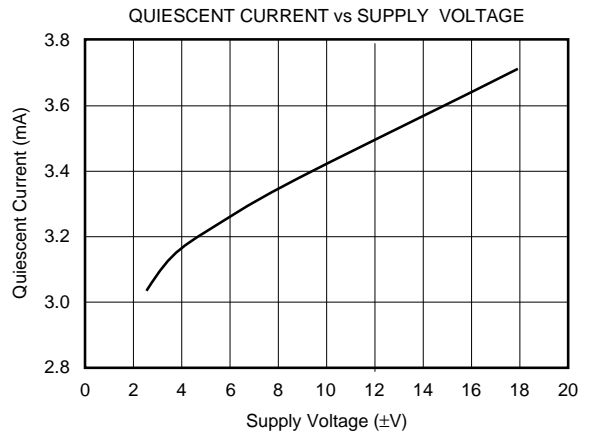
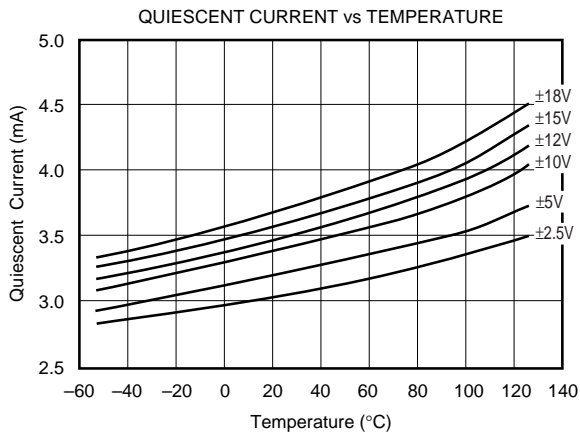
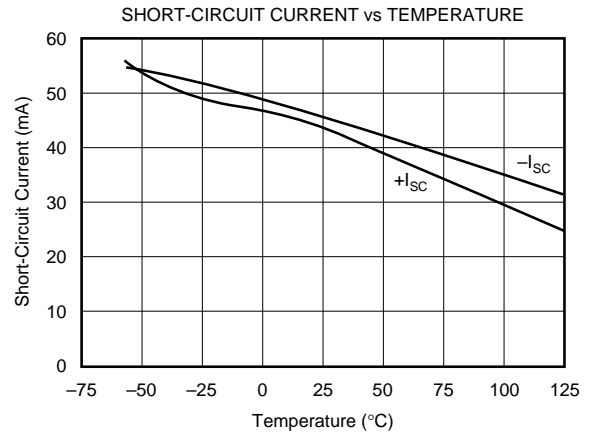
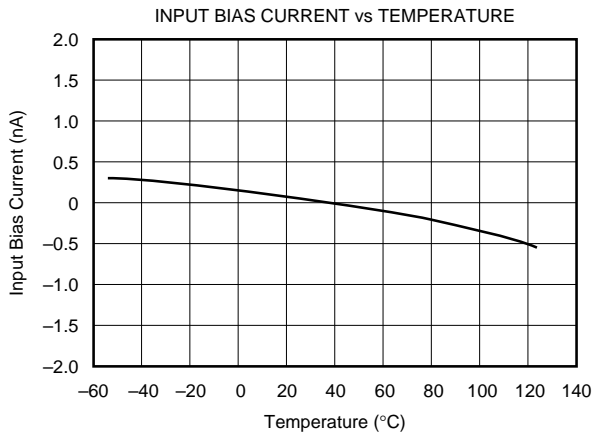
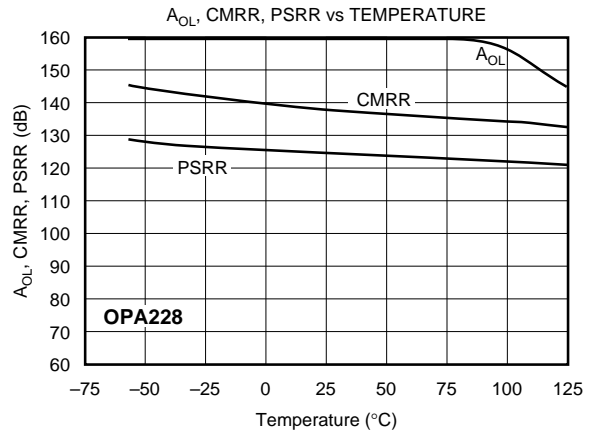
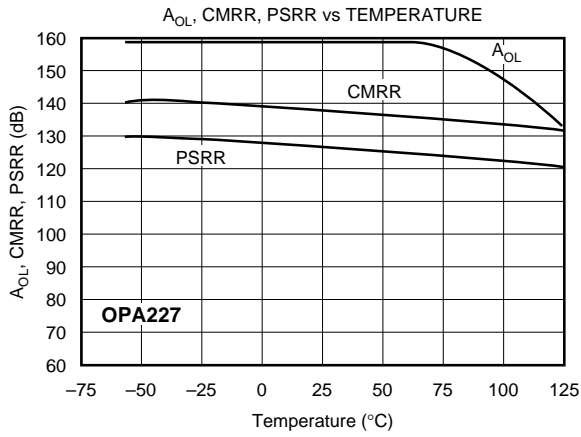

# TYPICAL PERFORMANCE CURVES (CONT)

At  $T_A = +25^\circ\text{C}$ ,  $R_L = 10\text{k}\Omega$ , and  $V_S = \pm 15\text{V}$ , unless otherwise noted.

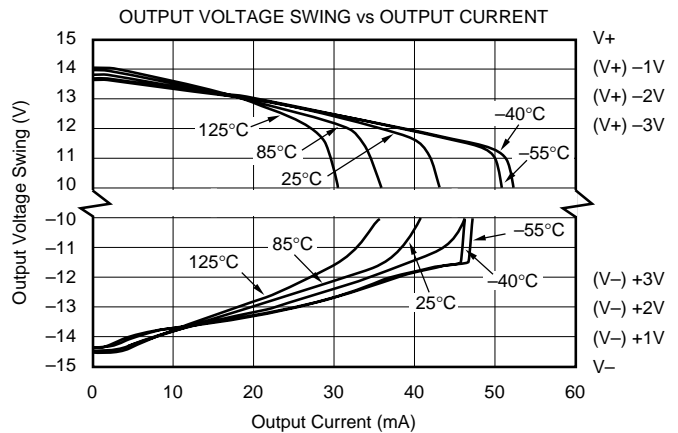
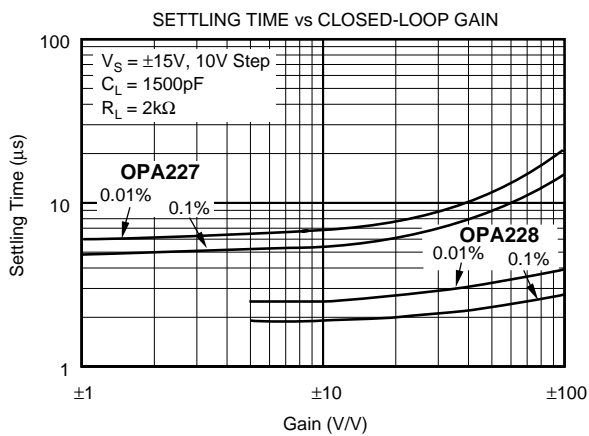
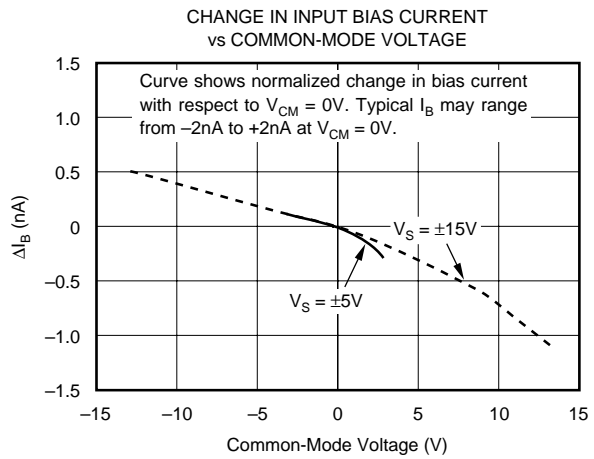
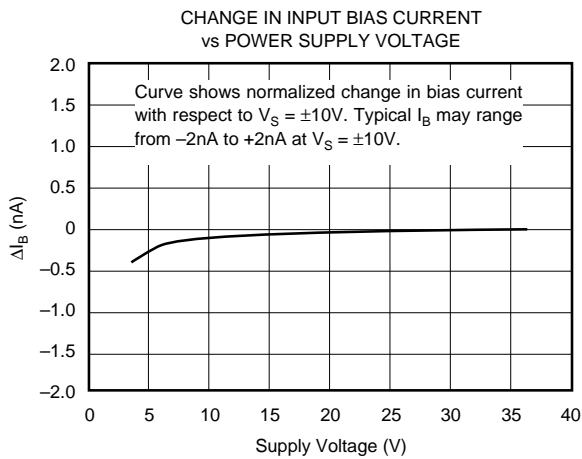
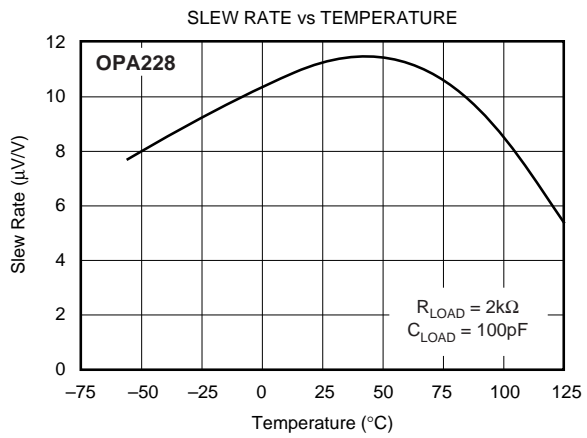
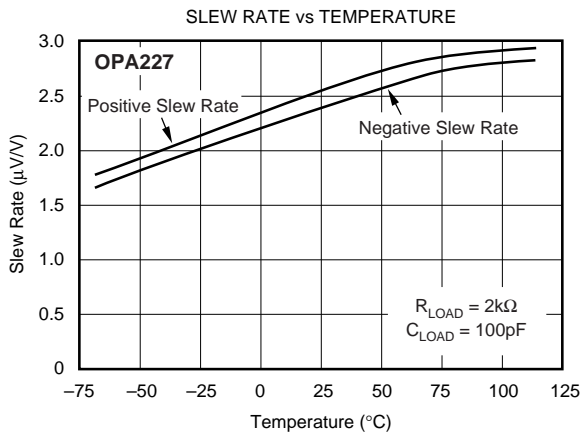



# TYPICAL PERFORMANCE CURVES (CONT)

At  $T_A = +25^\circ\text{C}$ ,  $R_L = 10\text{k}\Omega$ , and  $V_S = \pm 15\text{V}$ , unless otherwise noted.

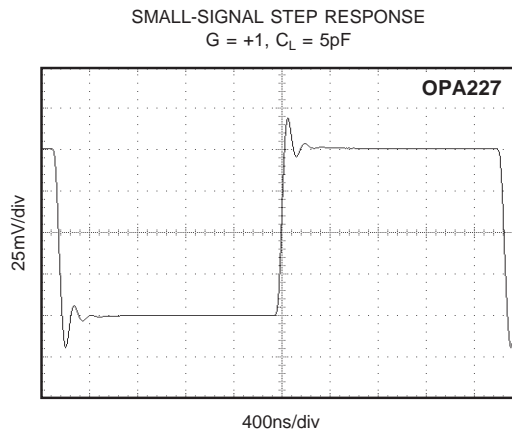
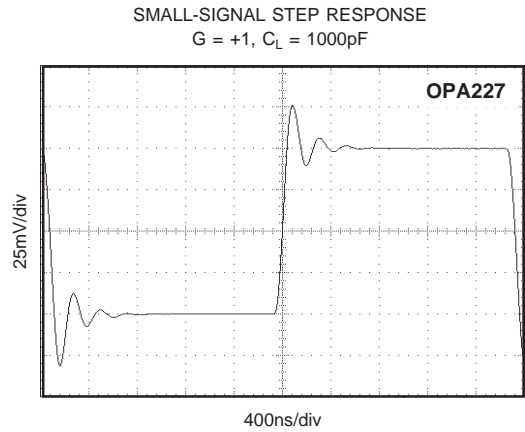
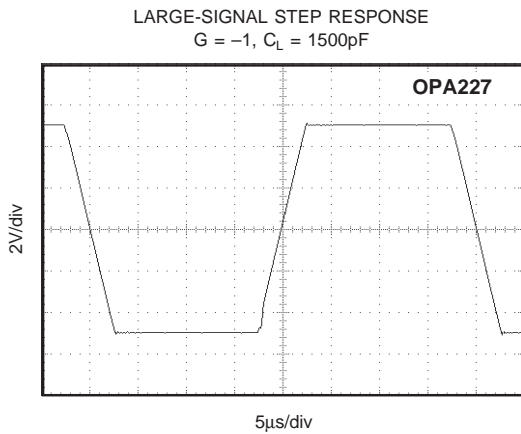
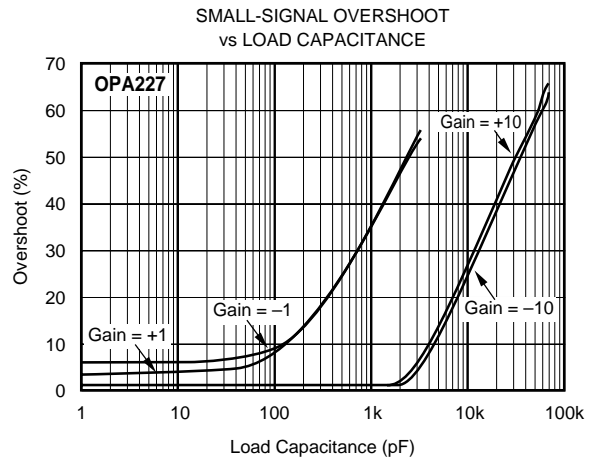
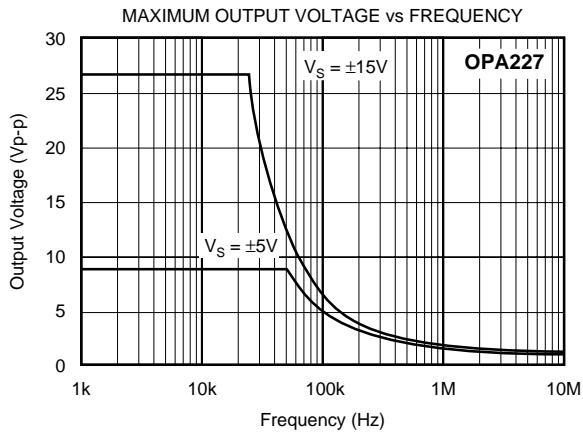

# TYPICAL PERFORMANCE CURVES (CONT)

At  $T_A = +25^\circ\text{C}$ ,  $R_L = 10\text{k}\Omega$ , and  $V_S = \pm 15\text{V}$ , unless otherwise noted.

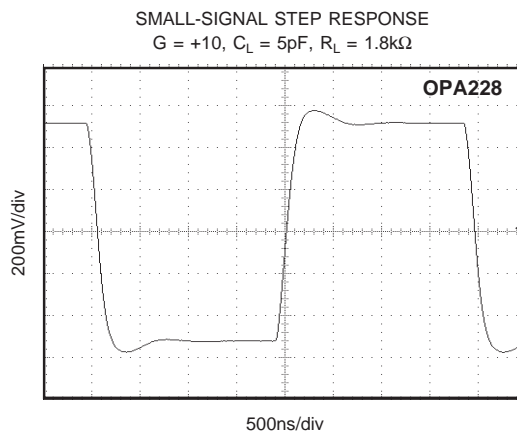
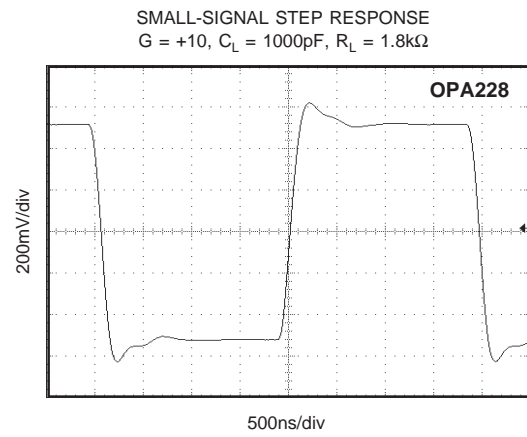
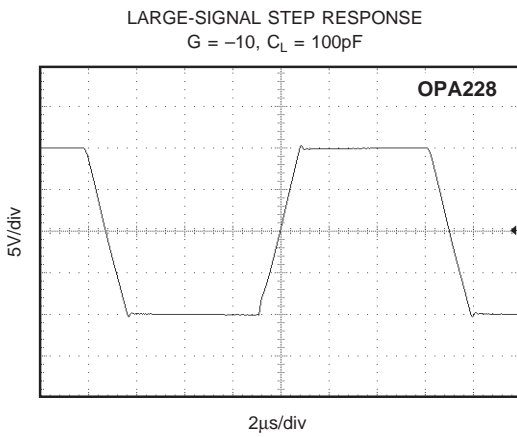
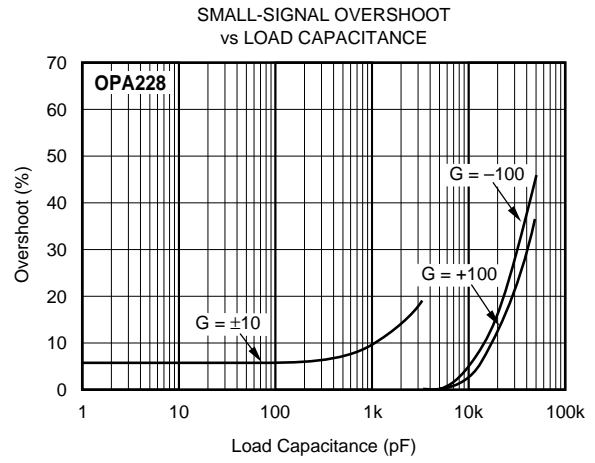
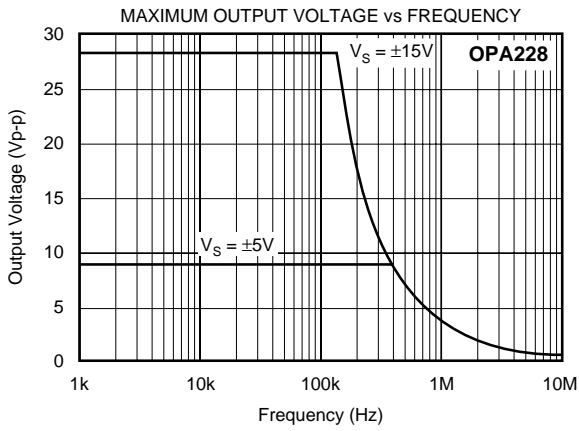

## APPLICATIONS INFORMATION

The OPA227 and OPA228 series are precision op amps with very low noise. The OPA227 series is unity-gain stable with a slew rate of 2.3V/μs and 8MHz bandwidth. The OPA228 series is optimized for higher-speed applications with gains of 5 or greater, featuring a slew rate of 10V/μs and 33MHz bandwidth. Applications with noisy or high impedance power supplies may require decoupling capacitors close to the device pins. In most cases, 0.1μF capacitors are adequate.

### OFFSET VOLTAGE AND DRIFT

The OPA227 and OPA228 series have very low offset voltage and drift. To achieve highest dc precision, circuit layout and mechanical conditions should be optimized. Connections of dissimilar metals can generate thermal potentials at the op amp inputs which can degrade the offset voltage and drift. These thermocouple effects can exceed the inherent drift of the amplifier and ultimately degrade its performance. The thermal potentials can be made to cancel by assuring that they are equal at both input terminals. In addition:

- Keep thermal mass of the connections made to the two input terminals similar.
- Locate heat sources as far as possible from the critical input circuitry.
- Shield op amp and input circuitry from air currents such as those created by cooling fans.

### OPERATING VOLTAGE

OPA227 and OPA228 series op amps operate from ±2.5V to ±18V supplies with excellent performance. Unlike most op amps which are specified at only one supply voltage, the OPA227 series is specified for real-world applications; a single set of specifications applies over the ±5V to ±15V supply range. Specifications are guaranteed for applications between ±5V and ±15V power supplies. Some applications do not require equal positive and negative output voltage swing. Power supply voltages do not need to be equal. The OPA227 and OPA228 series can operate with as little as 5V between the supplies and with up to 36V between the supplies. For example, the positive supply could be set to 25V with the negative supply at -5V or vice-versa. In addition, key parameters are guaranteed over the specified temperature range, -40°C to +85°C. Parameters which vary significantly with operating voltage or temperature are shown in the Typical Performance Curves.

### OFFSET VOLTAGE ADJUSTMENT

The OPA227 and OPA228 series are laser-trimmed for very low offset and drift so most applications will not require external adjustment. However, the OPA227 and OPA228 (single versions) provide offset voltage trim connections on pins 1 and 8. Offset voltage can be adjusted by connecting a potentiometer as shown in Figure 1. This adjustment should be used only to null the offset of the op

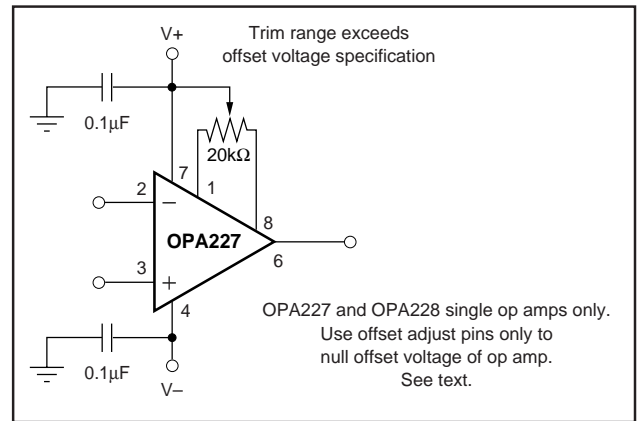

FIGURE 1. OPA227 Offset Voltage Trim Circuit.

amp. This adjustment should not be used to compensate for offsets created elsewhere in the system since this can introduce additional temperature drift.

### INPUT PROTECTION

Back-to-back diodes (see Figure 2) are used for input protection on the OPA227 and OPA228. Exceeding the turn-on threshold of these diodes, as in a pulse condition, can cause current to flow through the input protection diodes due to the amplifier's finite slew rate. Without external current-limiting resistors, the input devices can be destroyed. Sources of high input current can cause subtle damage to the amplifier. Although the unit may still be functional, important parameters such as input offset voltage, drift, and noise may shift.

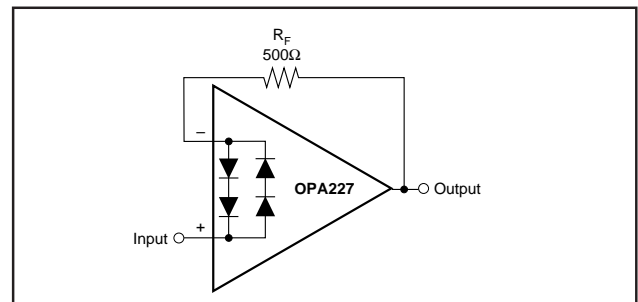

FIGURE 2. Pulsed Operation.

When using the OPA227 as a unity-gain buffer (follower), the input current should be limited to 20mA. This can be accomplished by inserting a feedback resistor or a resistor in series with the source. Sufficient resistor size can be calculated:

$$R_X = V_S / 20\text{mA} - R_{\text{SOURCE}}$$

where  $R_X$  is either in series with the source or inserted in the feedback path. For example, for a 10V pulse ( $V_S = 10\text{V}$ ), total loop resistance must be 500Ω. If the source impedance is large enough to sufficiently limit the current on its own, no additional resistors are needed. The size of any external resistors must be carefully chosen since they will increase noise. See the Noise Performance section of this data sheet for further information on noise calculation. Figure 2 shows an example implementing a current-limiting feedback resistor.

## INPUT BIAS CURRENT CANCELLATION

The input bias current of the OPA227 and OPA228 series is internally compensated with an equal and opposite cancellation current. The resulting input bias current is the difference between with input bias current and the cancellation current. The residual input bias current can be positive or negative.

When the bias current is cancelled in this manner, the input bias current and input offset current are approximately equal. A resistor added to cancel the effect of the input bias current (as shown in Figure 3) may actually increase offset and noise and is therefore not recommended.

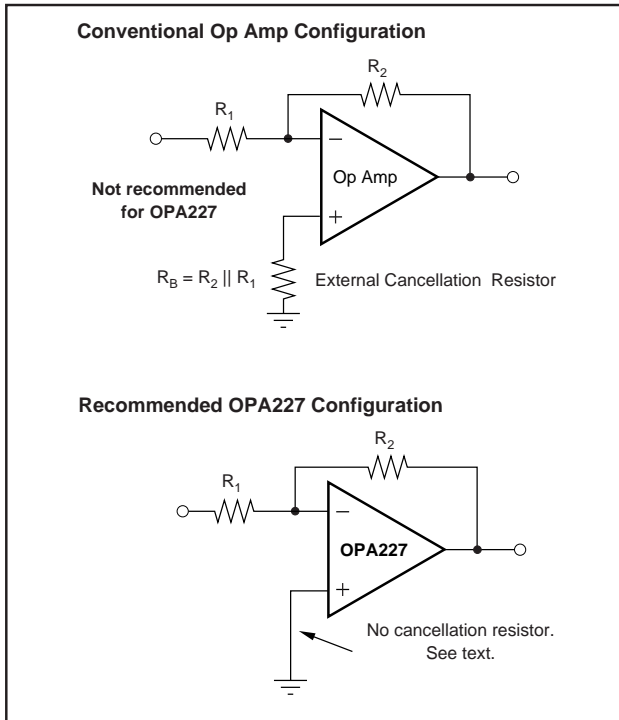

FIGURE 3. Input Bias Current Cancellation.

## NOISE PERFORMANCE

Figure 4 shows total circuit noise for varying source impedances with the op amp in a unity-gain configuration (no feedback resistor network, therefore no additional noise contributions). Two different op amps are shown with total circuit noise calculated. The OPA227 has very low voltage noise, making it ideal for low source impedances (less than 20kΩ). A similar precision op amp, the OPA277, has somewhat higher voltage noise but lower current noise. It provides excellent noise performance at moderate source impedance (10kΩ to 100kΩ). Above 100kΩ, a FET-input op amp such as the OPA132 (very low current noise) may provide improved performance. The equation is shown for the calculation of the total circuit noise. Note that  $e_n$  = voltage noise,  $i_n$  = current noise,  $R_S$  = source impedance,  $k$  = Boltzmann's constant =  $1.38 \cdot 10^{-23}$  J/K and  $T$  is temperature in K. For more details on calculating noise, see the insert titled "Basic Noise Calculations."

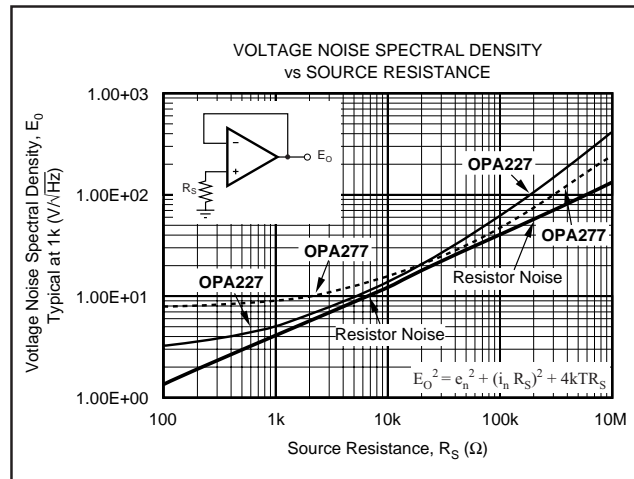

FIGURE 4. Noise Performance of the OPA227 in Unity-Gain Buffer Configuration.

## BASIC NOISE CALCULATIONS

Design of low noise op amp circuits requires careful consideration of a variety of possible noise contributors: noise from the signal source, noise generated in the op amp, and noise from the feedback network resistors. The total noise of the circuit is the root-sum-square combination of all noise components.

The resistive portion of the source impedance produces thermal noise proportional to the square root of the resistance. This function is shown plotted in Figure 4. Since the source impedance is usually fixed, select the op amp and the feedback resistors to minimize their contribution to the total noise.

Figure 4 shows total noise for varying source impedances with the op amp in a unity-gain configuration (no feedback resistor network and therefore no additional noise contributions). The operational amplifier itself contributes both a voltage noise component and a current

noise component. The voltage noise is commonly modeled as a time-varying component of the offset voltage. The current noise is modeled as the time-varying component of the input bias current and reacts with the source resistance to create a voltage component of noise. Consequently, the lowest noise op amp for a given application depends on the source impedance. For low source impedance, current noise is negligible and voltage noise generally dominates. For high source impedance, current noise may dominate.

Figure 5 shows both inverting and noninverting op amp circuit configurations with gain. In circuit configurations with gain, the feedback network resistors also contribute noise. The current noise of the op amp reacts with the feedback resistors to create additional noise components. The feedback resistor values can generally be chosen to make these noise sources negligible. The equations for total noise are shown for both configurations.

### Noise in Noninverting Gain Configuration

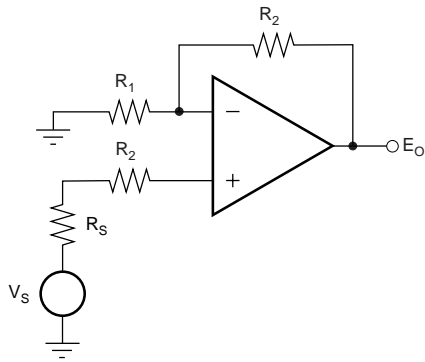

Noise at the output:

$$E_O^2 = \left(1 + \frac{R_2}{R_1}\right)^2 e_n^2 + e_1^2 + e_2^2 + (i_n R_2)^2 + e_s^2 + (i_n R_s)^2 \left(1 + \frac{R_2}{R_1}\right)^2$$

Where  $e_s = \sqrt{4kTR_s} \cdot \left(1 + \frac{R_2}{R_1}\right)$  = thermal noise of  $R_s$

$$e_1 = \sqrt{4kTR_1} \cdot \left(\frac{R_2}{R_1}\right) = \text{thermal noise of } R_1$$

$$e_2 = \sqrt{4kTR_2} = \text{thermal noise of } R_2$$

### Noise in Inverting Gain Configuration

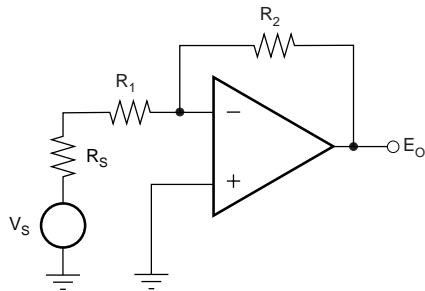

Noise at the output:

$$E_O^2 = \left(1 + \frac{R_2}{R_1 + R_s}\right)^2 e_n^2 + e_1^2 + e_2^2 + (i_n R_2)^2 + e_s^2$$

Where  $e_s = \sqrt{4kTR_s} \cdot \left(\frac{R_2}{R_1 + R_s}\right)$  = thermal noise of  $R_s$

$$e_1 = \sqrt{4kTR_1} \cdot \left(\frac{R_2}{R_1 + R_s}\right) = \text{thermal noise of } R_1$$

$$e_2 = \sqrt{4kTR_2} = \text{thermal noise of } R_2$$

For the OPA227 and OPA228 series op amps at 1kHz,  $e_n = 3\text{nV}/\sqrt{\text{Hz}}$  and  $i_n = 0.4\text{pA}/\sqrt{\text{Hz}}$ .

FIGURE 5. Noise Calculation in Gain Configurations.

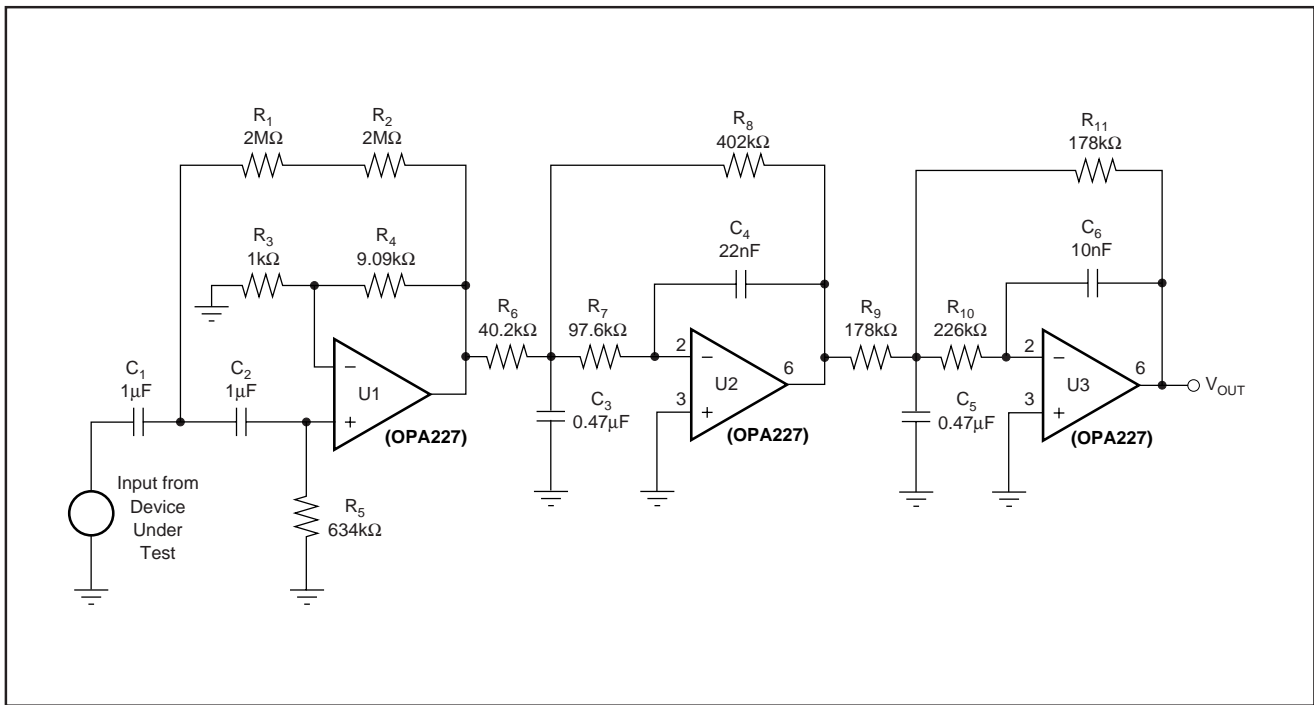

FIGURE 6. 0.1Hz to 10Hz Bandpass Filter Used to Test Wideband Noise of the OPA227 and OPA228 Series.

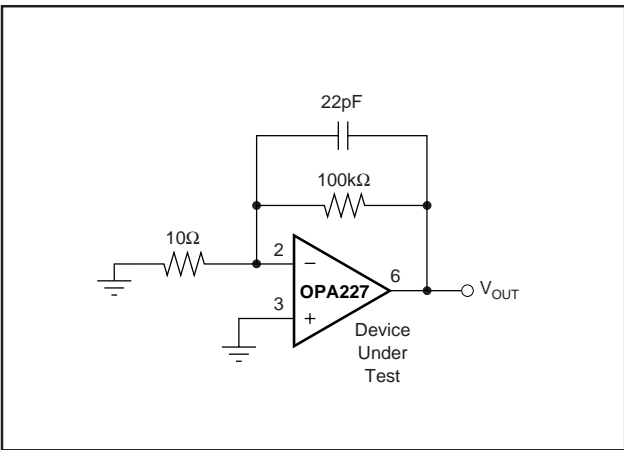

FIGURE 7. Noise Test Circuit.

Figure 6 shows the 0.1Hz 10Hz bandpass filter used to test the noise of the OPA227 and OPA228. The filter circuit was designed using Burr-Brown's FilterPro software (available at [www.burr-brown.com](http://www.burr-brown.com)). Figure 7 shows the configuration of the OPA227 and OPA228 for noise testing.

### USING THE OPA228 IN LOW GAINS

The OPA228 family is intended for applications with signal gains of 5 or greater, but it is possible to take advantage of their high speed in lower gains. Without external compensation, the OPA228 has sufficient phase margin to maintain stability in unity gain with purely resistive loads. However, the addition of load capacitance can reduce the phase margin and destabilize the op amp.

A variety of compensation techniques have been evaluated specifically for use with the OPA228. The recommended configuration consists of an additional capacitor ( $C_F$ ) in parallel with the feedback resistance, as shown in Figures 8 and 11. This feedback capacitor serves two purposes in compensating the circuit. The op amp's input capacitance and the feedback resistors interact to cause phase shift that can result in instability.  $C_F$  compensates the input capacitance, minimizing peaking. Additionally, at high frequencies, the closed-loop gain of the amplifier is strongly influenced by the ratio of the input capacitance and the feedback capacitor. Thus,  $C_F$  can be selected to yield good stability while maintaining high speed.

Without external compensation, the noise specification of the OPA228 is the same as that for the OPA227 in gains of 5 or greater. With the additional external compensation, the output noise of the OPA228 will be higher. The amount of noise increase is directly related to the increase in high frequency closed-loop gain established by the  $C_{IN}/C_F$  ratio.

Figures 8 and 11 show the recommended circuit for gains of +2 and -2, respectively. The figures suggest approximate

values for  $C_F$ . Because compensation is highly dependent on circuit design, board layout, and load conditions,  $C_F$  should be optimized experimentally for best results. Figures 9 and 10 show the large- and small-signal step responses for the  $G = +2$  configuration with 100pF load capacitance. Figures 12 and 13 show the large- and small-signal step responses for the  $G = -2$  configuration with 100pF load capacitance.

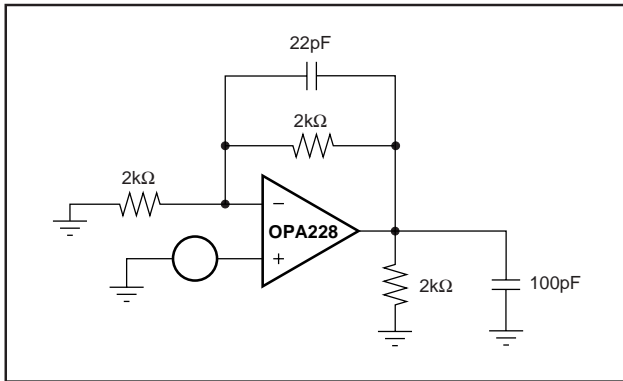

FIGURE 8. Compensation of the OPA228 for  $G = +2$ .

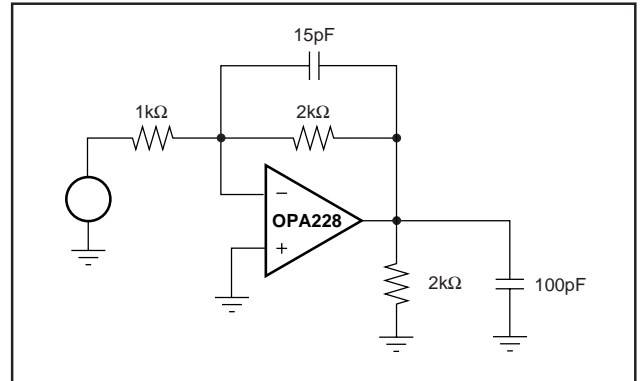

FIGURE 11. Compensation for OPA228 for  $G = -2$ .

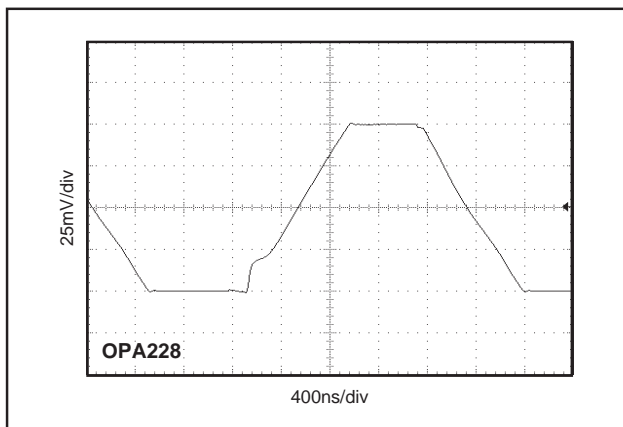

FIGURE 9. Large-Signal Step Response,  $G = +2$ ,  $C_{LOAD} = 100\text{pF}$ , Input Signal = 5Vp-p.

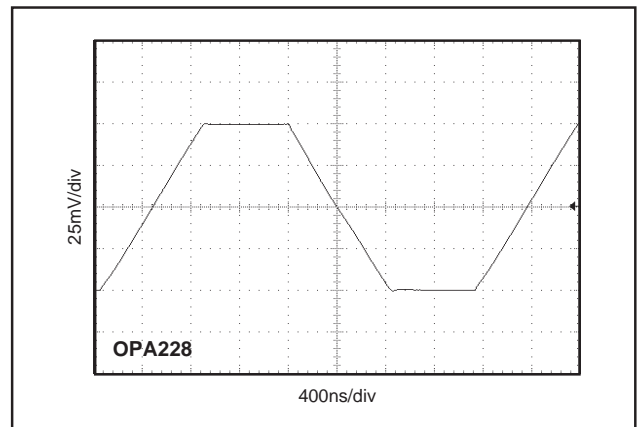

FIGURE 12. Large-Signal Step Response,  $G = -2$ ,  $C_{LOAD} = 100\text{pF}$ , Input Signal = 5Vp-p.

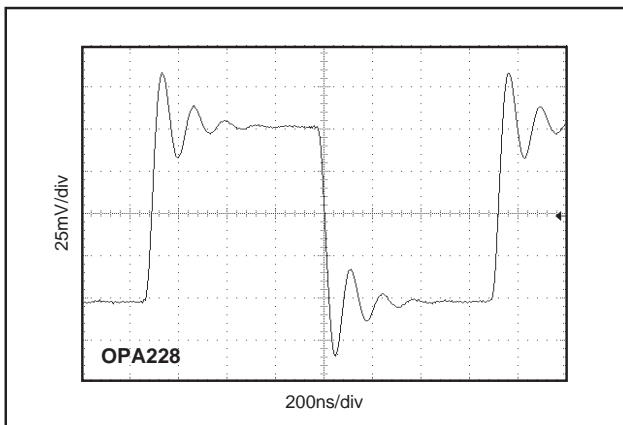

FIGURE 10. Small-Signal Step Response,  $G = +2$ ,  $C_{LOAD} = 100\text{pF}$ , Input Signal = 50mVp-p.

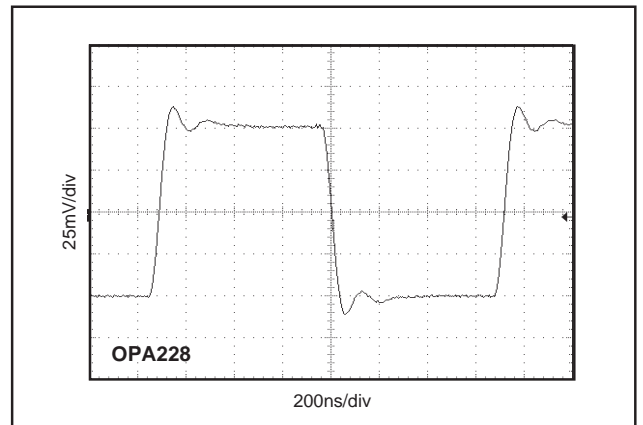

FIGURE 13. Small-Signal Step Response,  $G = -2$ ,  $C_{LOAD} = 100\text{pF}$ , Input Signal = 50mVp-p.

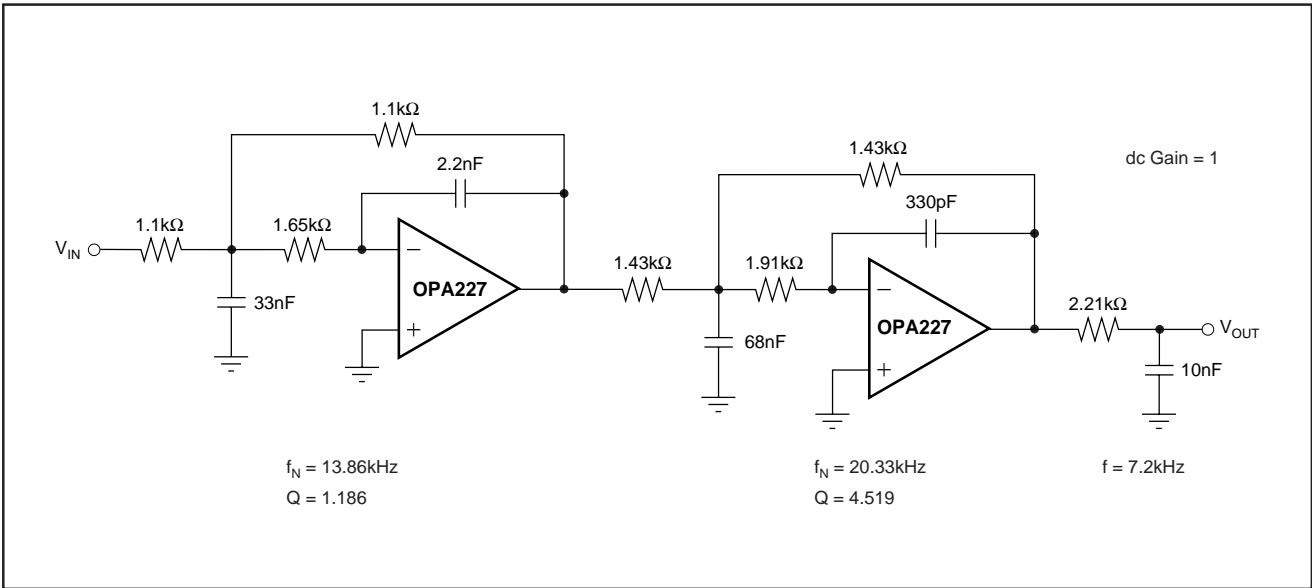

FIGURE 14. Three-Pole, 20kHz Low Pass, 0.5dB Chebyshev Filter.

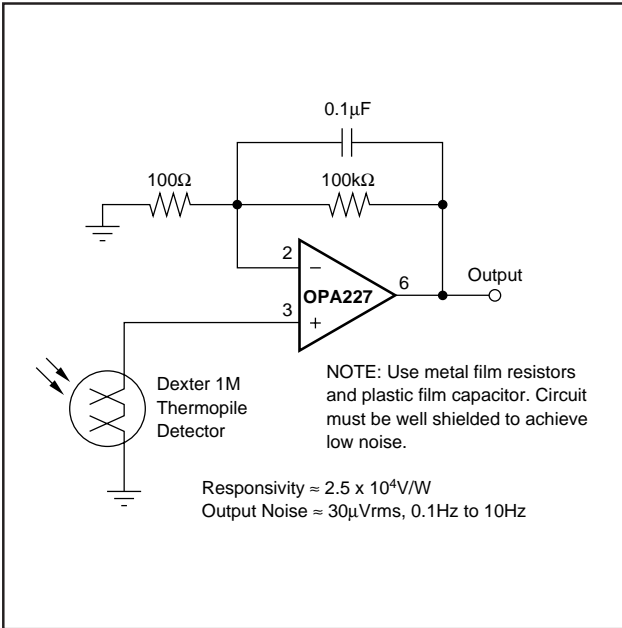

FIGURE 15. Long-Wavelength Infrared Detector Amplifier.

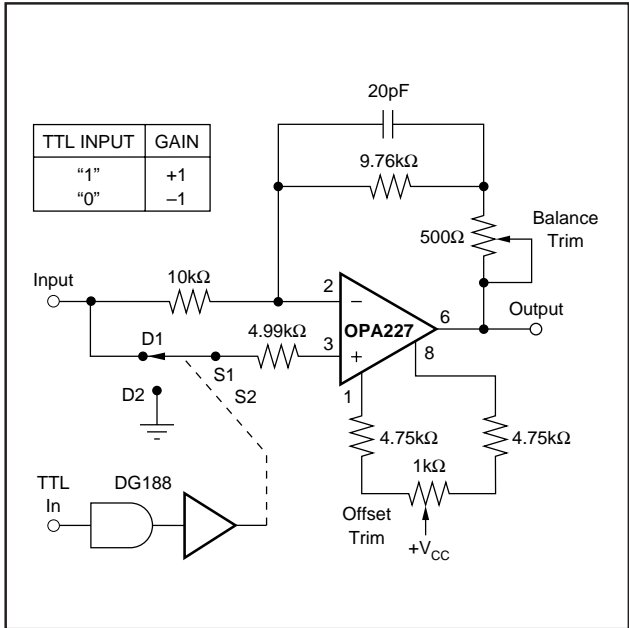

FIGURE 16. High Performance Synchronous Demodulator.



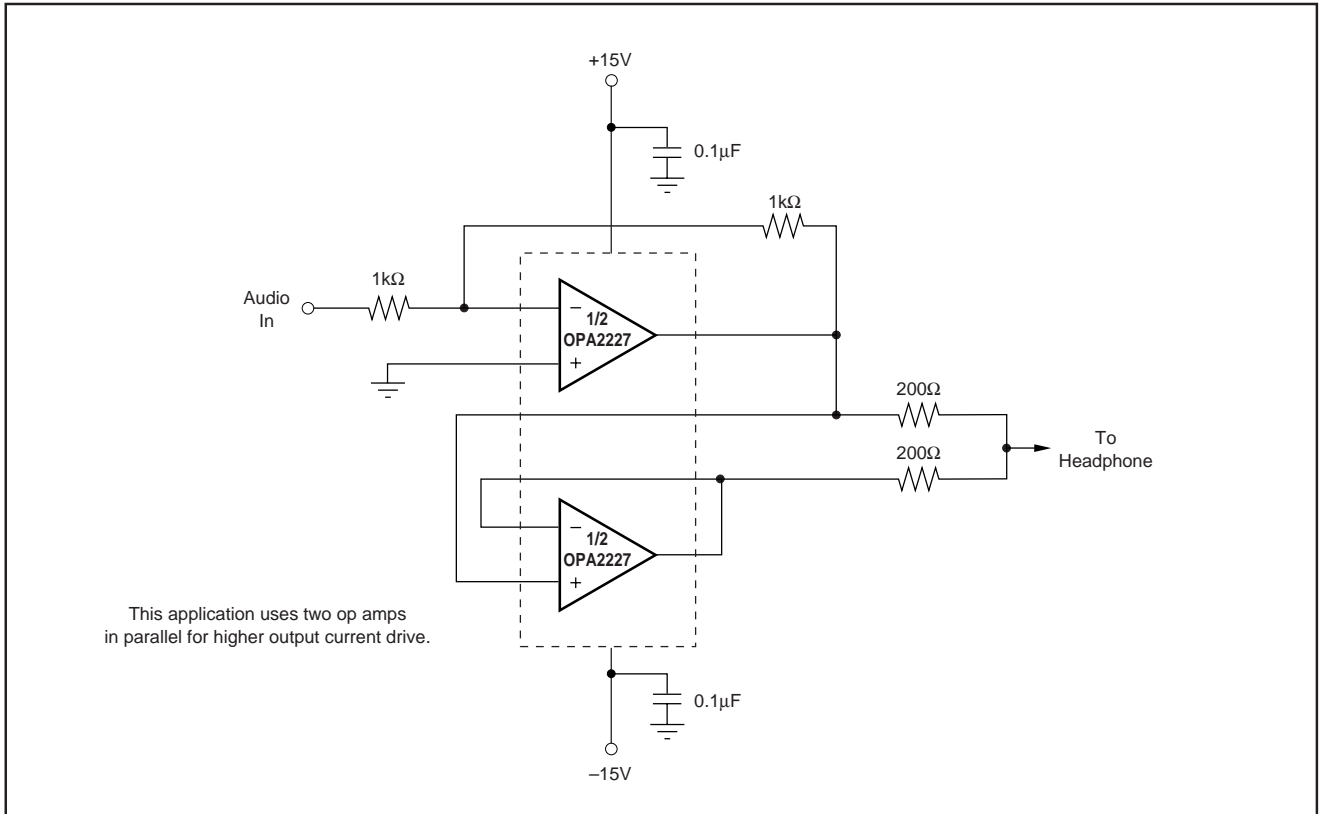

FIGURE 17. Headphone Amplifier.

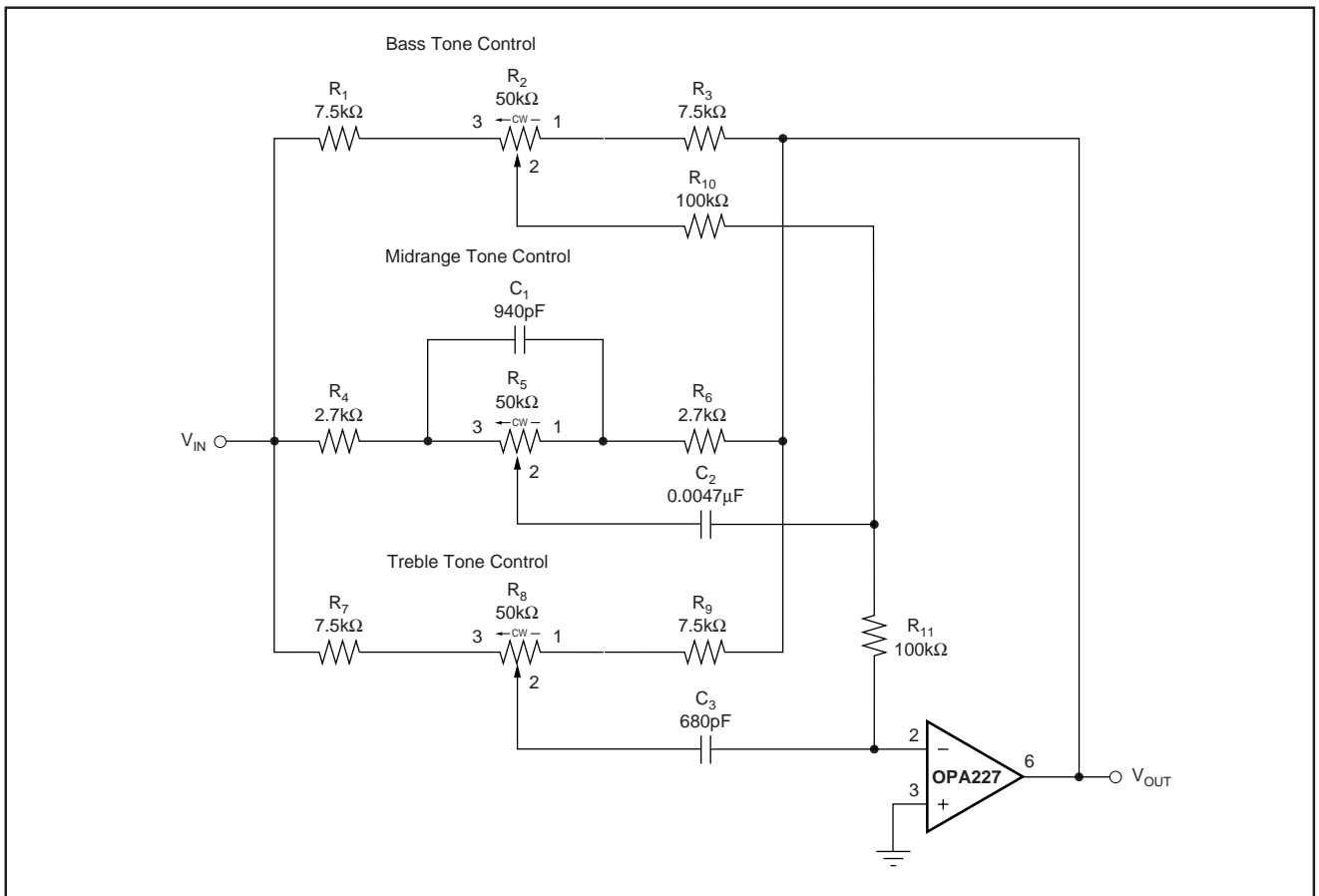

FIGURE 18. Three-Band ActiveTone Control (bass, midrange and treble).