

OPA2658

Dual Wideband, Low Power, Current Feedback OPERATIONAL AMPLIFIER

FEATURES

- UNITY GAIN STABLE BANDWIDTH: 800MHz
- LOW POWER: 50mW/Chan.
- LOW DIFFERENTIAL GAIN/PHASE ERRORS: 0.01%/0.03°
- HIGH SLEW RATE: 1700V/ μ s
- PACKAGE: 8-Pin DIP, SO-8 and MSOP-8

APPLICATIONS

- MEDICAL IMAGING
- HIGH-RESOLUTION VIDEO
- HIGH-SPEED SIGNAL PROCESSING
- COMMUNICATIONS
- PULSE AMPLIFIERS
- ADC/DAC GAIN AMPLIFIER
- MONITOR PREAMPLIFIER
- CCD IMAGING AMPLIFIER

DESCRIPTION

The OPA2658 is a dual, ultra-wideband, low power current feedback video operational amplifier featuring high slew rate and low differential gain/phase error. The current feedback design allows for superior large signal bandwidth, even at high gains. The low differential gain/phase errors, wide bandwidth and low

quiescent current make the OPA2658 a perfect choice for numerous video, imaging and communications applications.

The OPA2658 is optimized for low gain operation, and is also available in single, OPA658 and quad, OPA4658 configurations.

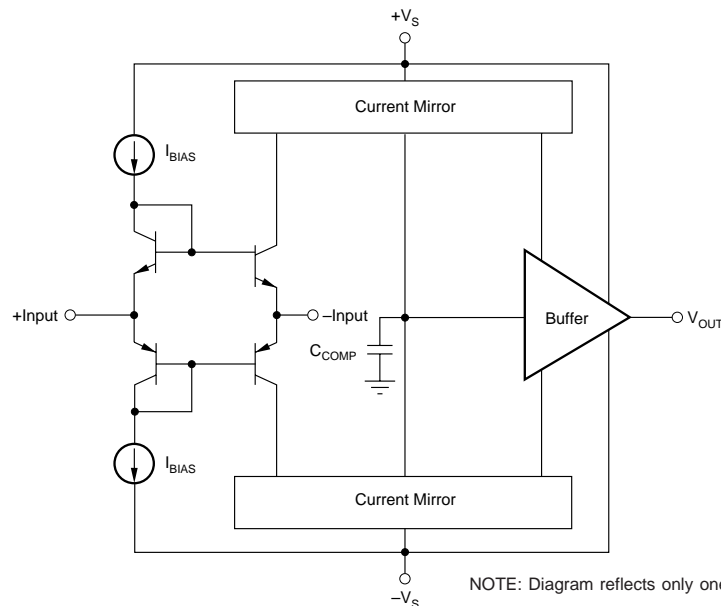

International Airport Industrial Park • Mailing Address: PO Box 11400, Tucson, AZ 85734 • Street Address: 6730 S. Tucson Blvd., Tucson, AZ 85706 • Tel: (520) 746-1111 • Twx: 910-952-1111
Internet: <http://www.burr-brown.com/> • FAXLine: (800) 548-6133 (US/Canada Only) • Cable: BBRCORP • Telex: 066-6491 • FAX: (520) 889-1510 • Immediate Product Info: (800) 548-6132

SPECIFICATIONS

At $T_A = +25^\circ\text{C}$, $V_S = \pm 5\text{V}$, $R_L = 100\Omega$, $R_{FB} = 402\Omega$, unless otherwise noted.

PARAMETER	CONDITION	OPA2658P, U, E			OPA2658UB			UNITS
		MIN	TYP	MAX	MIN	TYP	MAX	
FREQUENCY RESPONSE Closed-Loop Bandwidth ⁽²⁾	$G = +1^{(3)}$		800			* ⁽¹⁾		MHz
	$G = +2$		500		300	*		MHz
	$G = +5$		210			*		MHz
	$G = +10$		130			*		MHz
Bandwidth for 0.1dB Flatness ⁽²⁾	$V_O < 0.5\text{Vp-p}$		135			*		MHz
Slew Rate ⁽⁴⁾	$G = +2, 2\text{V Step}$		1700		1000	*		V/ μs
Over Temperature Range			1500		900	*		V/ μs
Settling Time: 0.01%	$G = +2, 2\text{V Step}$		15			*		ns
0.1%	$G = +2, 2\text{V Step}$		12.6			*		ns
1%	$G = +2, 2\text{V Step}$		4.8			*		ns
Spurious Free Dynamic Range	$f = 5\text{MHz}, G = +2, V_O = 2\text{Vp-p}$		68			*		dB
	$f = 20\text{MHz}, G = +2, V_O = 2\text{Vp-p}$		56			*		dB
	$f = 10\text{MHz}, 4\text{dBm, Each Tone}$		39			*		dBm
Third-Order Intercept Point	$G = +2, \text{NTSC}, V_O = 1.4\text{Vp-p}, R_L = 150\Omega$		0.01			*		%
Differential Gain	$G = +2, \text{NTSC}, V_O = 1.4\text{Vp-p}, R_L = 150\Omega$		0.03			*		degrees
Differential Phase			-78			*		dB
Crosstalk	Input Referred, 5MHz, Channel-to-Channel					*		
OFFSET VOLTAGE Input Offset Voltage	$V_{CM} = 0\text{V}$		± 3	± 5.5		± 2	± 4.5	mV
Over Temperature Range			± 5	± 8		± 4	± 7	mV
Power Supply Rejection	Input Referred, $V_S = \pm 4.5$ to $\pm 5.5\text{V}$	55	64		58	68		dB
INPUT BIAS CURRENT Non-Inverting	$V_{CM} = 0\text{V}$		± 4.0	± 30		*	± 18	μA
Over Temperature Range			± 10	± 80		*	± 35	μA
Inverting	$V_{CM} = 0\text{V}$		± 2.9	± 35		*	*	μA
Over Temperature Range			± 30	± 75		*	*	μA
NOISE Input Voltage Noise								$\text{nV}/\sqrt{\text{Hz}}$
Noise Density: $f = 100\text{Hz}$			16			*		$\text{nV}/\sqrt{\text{Hz}}$
$f = 10\text{kHz}$			3.6			*		$\text{nV}/\sqrt{\text{Hz}}$
$f \geq 1\text{MHz}$			3.2			*		$\text{nV}/\sqrt{\text{Hz}}$
Integrated Noise:								μVrms
$f_B = 100\text{Hz}$ to 200MHz			45			*		
Input Bias Current Noise Density								$\text{pA}/\sqrt{\text{Hz}}$
Inverting: $f \geq 1\text{MHz}$			32			*		$\text{pA}/\sqrt{\text{Hz}}$
Non-Inverting: $f \geq 1\text{MHz}$			11.9			*		$\text{pA}/\sqrt{\text{Hz}}$
INPUT VOLTAGE RANGE Common-mode Input Range			± 2.9			*	*	V
Over Temperature Range		± 2.5			*	*		V
Common-mode Rejection	Input Referred, $V_{CM} = \pm 1\text{V}$	45	50		*	*		dB
INPUT IMPEDANCE Non-Inverting			500 1			*		k Ω pF
Inverting			50			*		Ω
OPEN-LOOP TRANSIMPEDANCE Open-loop Transimpedance	$V_O = \pm 2\text{V}, R_L = 100\Omega$	150	180		200	*		k Ω
Over Temperature Range		100			150			k Ω
OUTPUT Voltage Output	No Load	± 2.7	± 3.0		*	*		V
Over Temperature Range		± 2.5	± 2.8		*	*		V
Voltage Output	$R_L = 250\Omega$	± 2.7	± 2.9		*	*		V
Over Temperature Range		± 2.5	± 2.8		*	*		V
Voltage Output	$R_L = 100\Omega$	± 2.2	± 2.6		*	*		V
Over Temperature Range		± 2.0	± 2.4		*	*		V
Output Current, Sourcing		80	120		*	*		mA
Over Temperature Range		70			*	*		mA
Output Current, Sinking		60	80		*	*		mA
Over Temperature Range		35			*	*		mA
Short Circuit Current			150			*		mA
Output Resistance	$f < 100\text{kHz}, G = +2$		0.06			*		Ω
POWER SUPPLY Specified Operating Voltage		± 4.5	± 5	± 5.5	*	*		V
Operating Voltage Range				± 15.5		*	*	V
Quiescent Current	Both Channels, $V_S = \pm 5\text{V}$		± 10	± 15.5		*	± 11.5	mA
Over Temperature Range			± 11	± 17		*	± 13	mA
THERMAL CHARACTERISTICS Temperature Range	Specification: P, U, E, UB	-40		+85	*		*	$^\circ\text{C}$
Thermal Resistance, θ_{JA}			100			*		$^\circ\text{C}/\text{W}$
P 8-Pin DIP			125			*		$^\circ\text{C}/\text{W}$
U SO-8			150			*		$^\circ\text{C}/\text{W}$
E MSOP-8						*		$^\circ\text{C}/\text{W}$

NOTES: (1) An asterisk (*) specifies the same value as the grade to the left. (2) Frequency response can be strongly influenced by PC board parasitics. The demonstration boards show low parasitic layouts for this part. Refer to the demonstration board layout for details. (3) At $G = +1$, $R_{FB} = 560\Omega$ for DIP and MSOP-8, and 402Ω for SO-8. (4) Slew rate is rate of change from 10% to 90% of output voltage step.

ABSOLUTE MAXIMUM RATINGS

Supply Voltage	$\pm 5.5V$
Internal Power Dissipation	See Thermal Characteristics
Differential Input Voltage	$\pm 1.2V$
Input Voltage Range	$\pm V_S$
Storage Temperature Range: P, U, UB, E	$-40^{\circ}C$ to $+125^{\circ}C$
Lead Temperature (DIP, soldering, 10s)	$+300^{\circ}C$
(SO-8 and MSOP-8, soldering, 3s)	$+260^{\circ}C$
Junction Temperature (T_J)	$+175^{\circ}C$

PIN CONFIGURATION

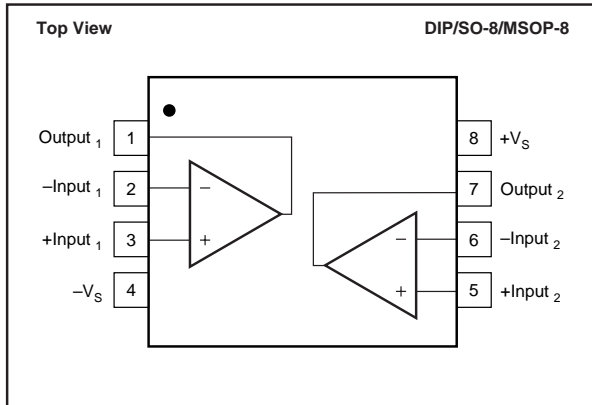

ELECTROSTATIC DISCHARGE SENSITIVITY

This integrated circuit can be damaged by ESD. Burr-Brown recommends that all integrated circuits be handled with appropriate precautions. Failure to observe proper handling and installation procedures can cause damage.

ESD damage can range from subtle performance degradation to complete device failure. Precision integrated circuits may be more susceptible to damage because very small parametric changes could cause the device not to meet its published specifications.

PACKAGE/ORDERING INFORMATION

PRODUCT	PACKAGE	PACKAGE DRAWING NUMBER ⁽¹⁾	TEMPERATURE RANGE	PACKAGE MARKING ⁽²⁾	ORDERING NUMBER ⁽³⁾
OPA2658P	8-Pin Plastic DIP	006	$-40^{\circ}C$ to $+85^{\circ}C$	OPA2658P	OPA2658P
OPA2658U	SO-8 Surface Mount	182	$-40^{\circ}C$ to $+85^{\circ}C$	OPA2658U	OPA2658U
OPA2658UB	SO-8 Surface Mount	182	$-40^{\circ}C$ to $+85^{\circ}C$	OPA2658UB	OPA2658UB
OPA2658E	8-Pin MSOP-8	337	$-40^{\circ}C$ to $+85^{\circ}C$	B58	OPA2658E-250 OPA2658E-2500

NOTE: (1) For detailed drawing and dimension table, see end of data sheet, or Appendix C of Burr-Brown IC Data Book. (2) The "B" grade will be marked with a "B" by pin 8. (3) The MSOP-8 is available on 7" tape and reel with 250 parts, and on 14" tape and reel with 2500 parts. For example, ordering 250 pieces of "OPA2658E-250" will get a single 250 piece tape and reel. Refer to Appendix B of Burr-Brown IC Data Book for detailed Tape and Reel Mechanical information.

The information provided herein is believed to be reliable; however, BURR-BROWN assumes no responsibility for inaccuracies or omissions. BURR-BROWN assumes no responsibility for the use of this information, and all use of such information shall be entirely at the user's own risk. Prices and specifications are subject to change without notice. No patent rights or licenses to any of the circuits described herein are implied or granted to any third party. BURR-BROWN does not authorize or warrant any BURR-BROWN product for use in life support devices and/or systems.

TYPICAL PERFORMANCE CURVES

At $T_A = +25^\circ\text{C}$, $V_S = \pm 5\text{V}$, $R_L = 100\Omega$, $R_{FB} = 402\Omega$, unless otherwise noted.

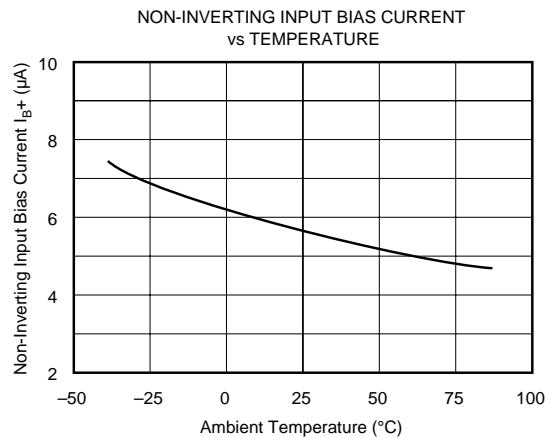
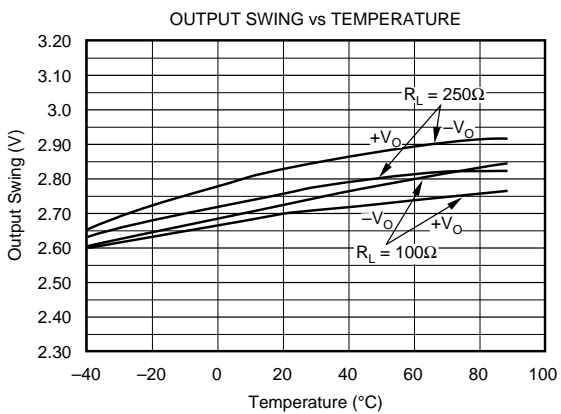
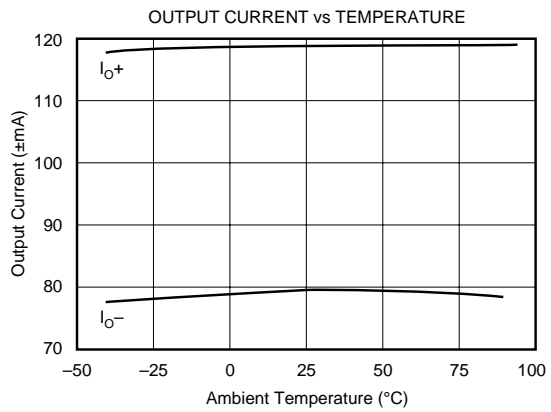
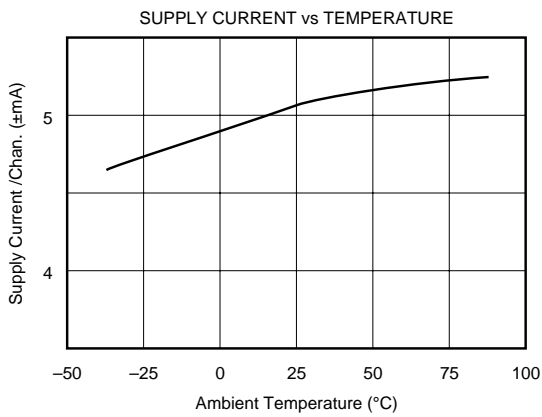
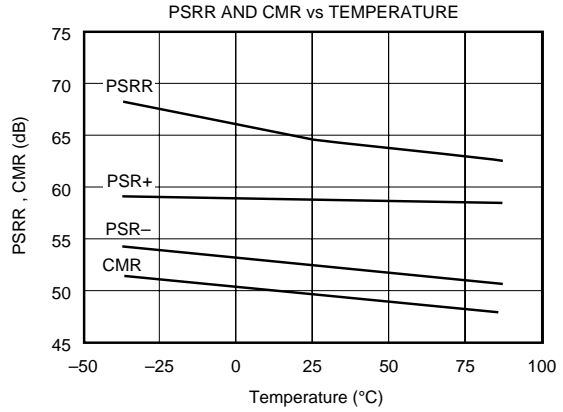
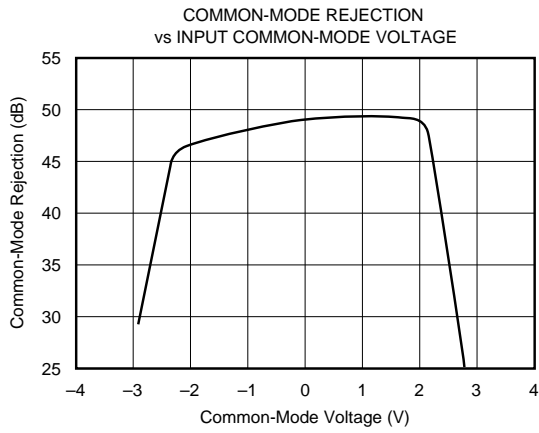

TYPICAL PERFORMANCE CURVES (CONT)

At $T_A = +25^\circ\text{C}$, $V_S = \pm 5\text{V}$, $R_L = 100\Omega$, $R_{FB} = 402\Omega$, unless otherwise noted.

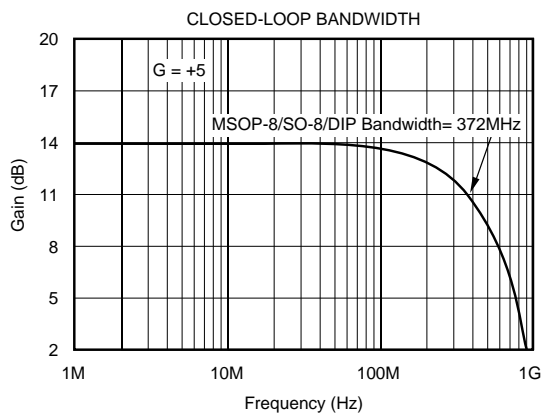
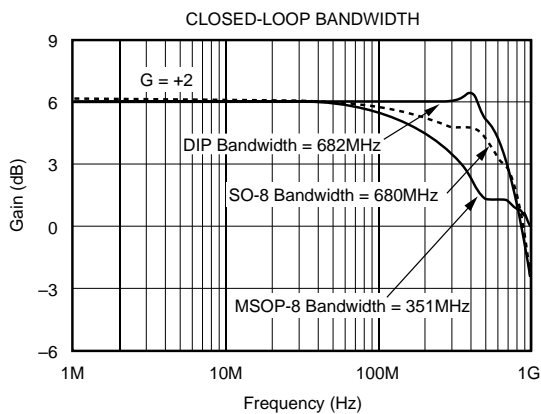
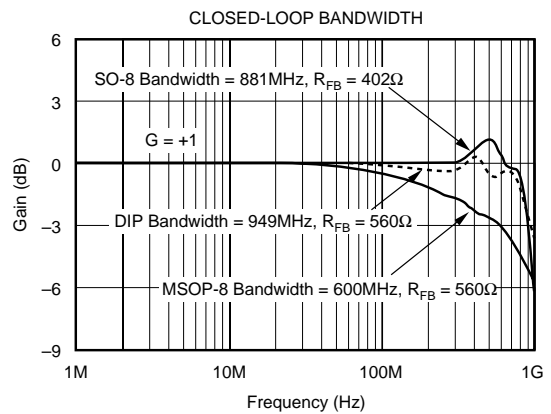
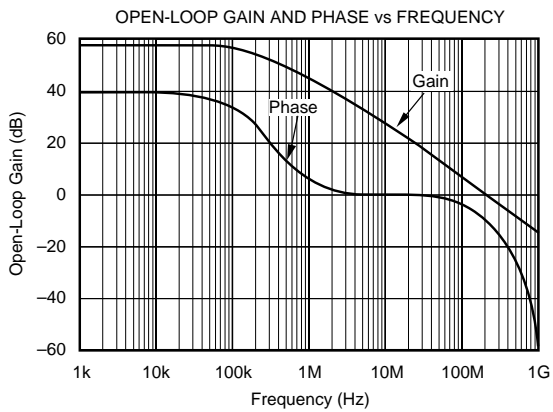
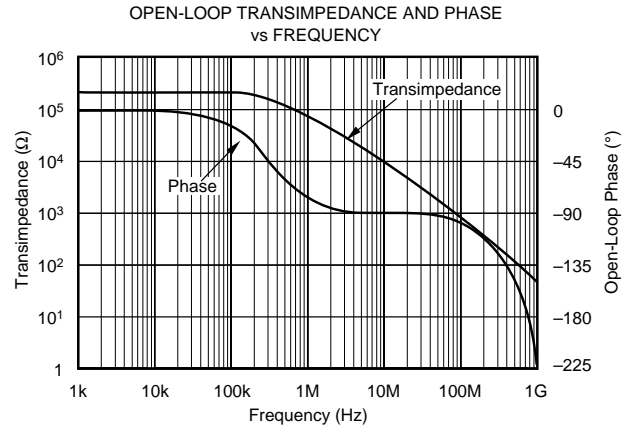
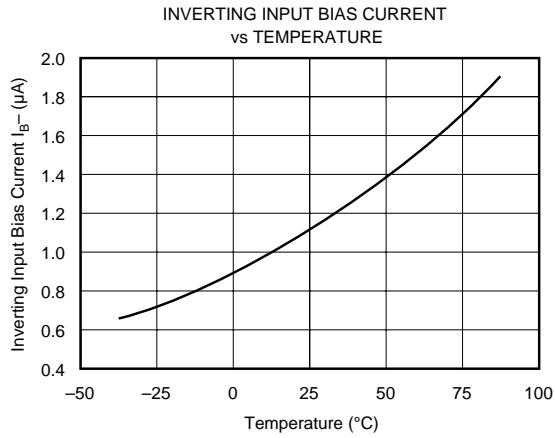

TYPICAL PERFORMANCE CURVES (CONT)

At $T_A = +25^\circ\text{C}$, $V_S = \pm 5\text{V}$, $R_L = 100\Omega$, $R_{FB} = 402\Omega$, unless otherwise noted.

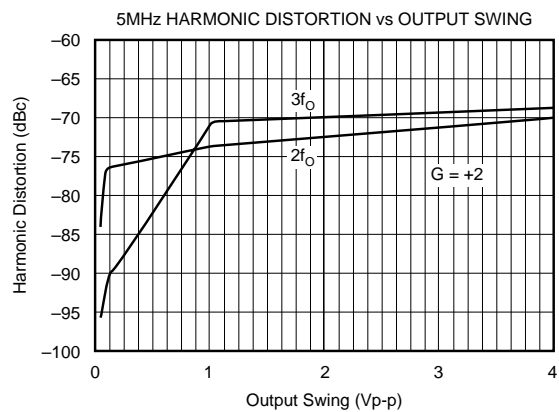
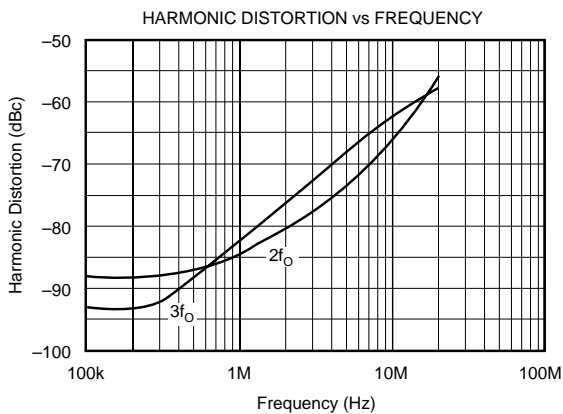
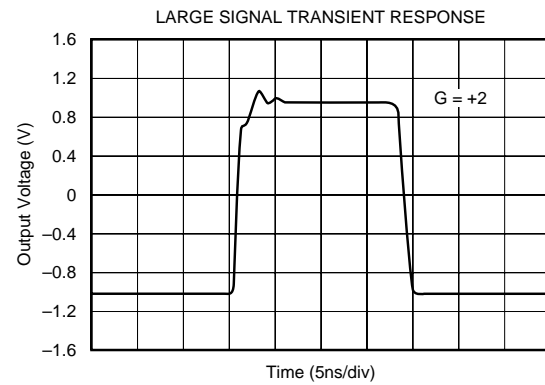
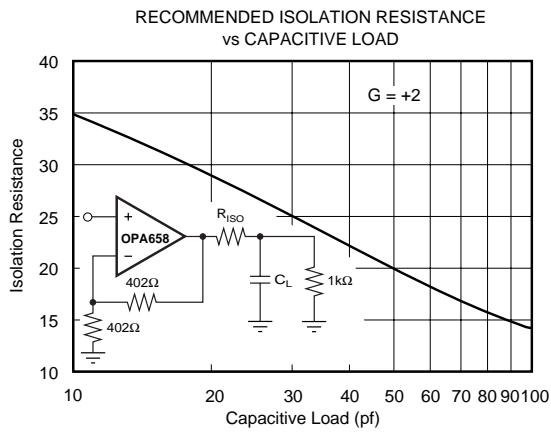
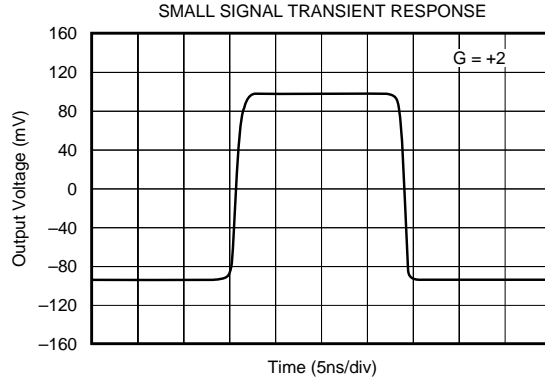
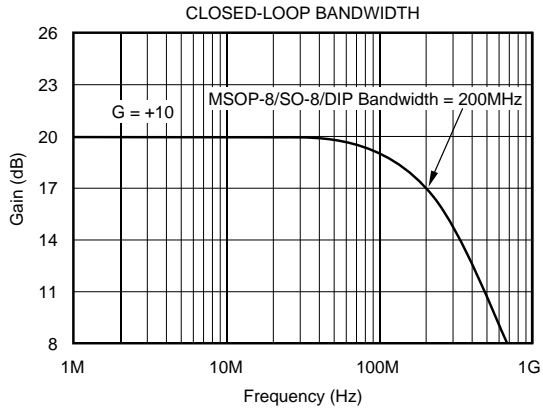

TYPICAL PERFORMANCE CURVES (CONT)

At $T_A = +25^\circ\text{C}$, $V_S = \pm 5\text{V}$, $R_L = 100\Omega$, $R_{FB} = 402\Omega$, unless otherwise noted.

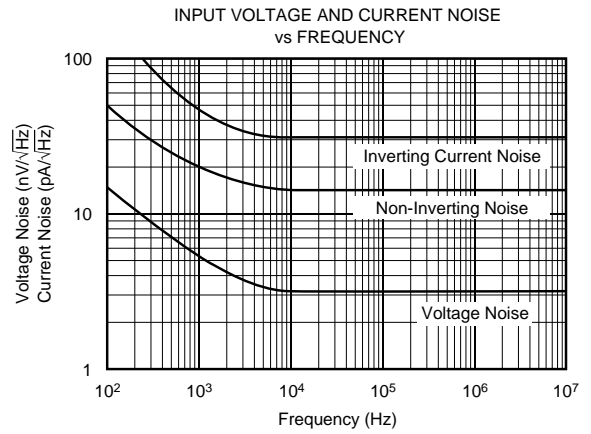
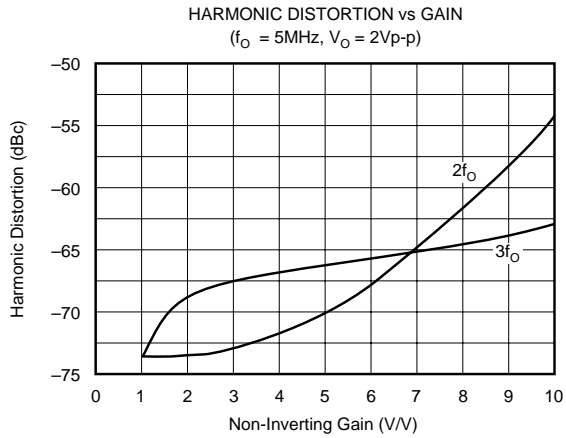
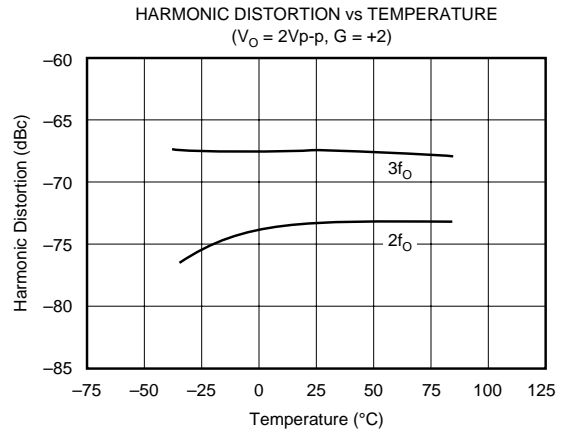
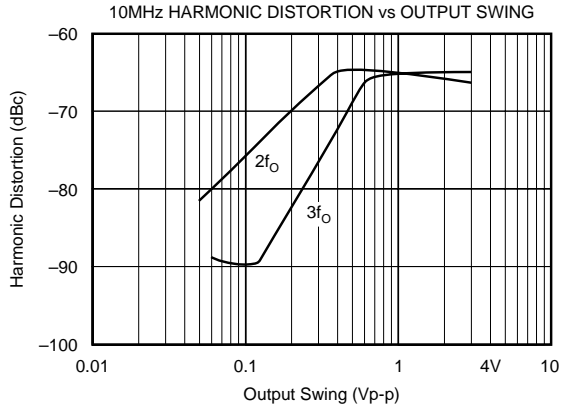

APPLICATIONS INFORMATION

THEORY OF OPERATION

Conventional op amps depend on feedback to drive their inputs to the same potential, however the current feedback op amp's inverting and non-inverting inputs are connected by a unity gain buffer, thus enabling the inverting input to automatically assume the same potential as the non-inverting input. This results in very low impedance at the inverting input, which makes it a very good current sensor. The feedback loop reduces the error current seen at the inverting input to a very small value.

DISCUSSION OF PERFORMANCE

The OPA2658 is a dual, low-power, unity gain stable, current feedback operational amplifier which operates on $\pm 5V$ power supply. The current feedback architecture offers the following important advantages over voltage feedback architectures: (1) the high slew rate allows the large signal performance to approach the small signal performance, and (2) there is very little bandwidth degradation at higher gain settings.

The current feedback architecture of the OPA2658 provides the traditional strength of excellent large signal response plus wide bandwidth, making it a good choice for use in high resolution video, medical imaging and DAC I/V Conversion. The low power requirements make it an excellent choice for numerous portable applications.

DC GAIN TRANSFER CHARACTERISTICS

The circuit in Figure 1 shows the equivalent circuit for calculating the DC gain. When operating the device in the inverting mode, the input signal error current (I_E) is amplified by the open loop transimpedance gain (T_O). The output signal generated is equal to $T_O \times I_E$. Negative feedback is applied through R_{FB} such that the device operates at a gain equal to $-R_{FB}/R_{FF}$.

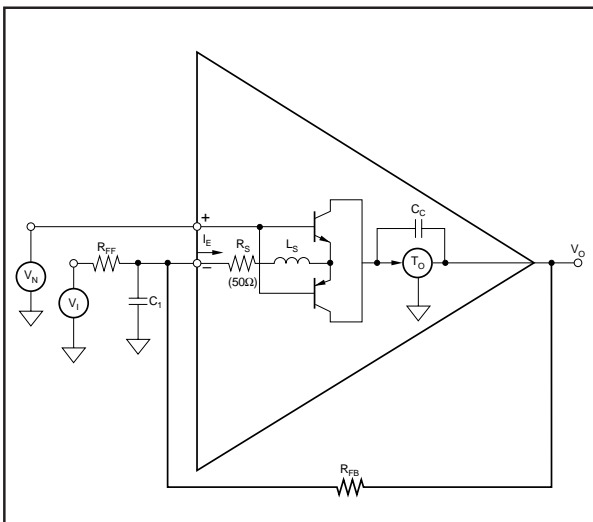

FIGURE 1. Equivalent Circuit. (1/2 of OPA2658)

For non-inverting operation, the input signal is applied to the non-inverting (high impedance buffer) input. The output (buffer) error current (I_E) is generated at the low impedance inverting input. The signal generated at the output is fed back to the inverting input such that the overall gain is $(1 + R_{FB}/R_{FF})$. Where a voltage-feedback amplifier has two symmetrical high impedance inputs, a current feedback amplifier has a low inverting (buffer output) impedance and a high non-inverting (buffer input) impedance.

The closed-loop gain for the OPA2658 can be calculated using the following equations:

$$\text{Inverting Gain} = \frac{-\left(\frac{R_{FB}}{R_{FF}}\right)}{1 + \frac{1}{\text{Loop Gain}}} \quad (1)$$

$$\text{Non-Inverting Gain} = \frac{\left[1 + \frac{R_{FB}}{R_{FF}}\right]}{1 + \frac{1}{\text{Loop Gain}}} \quad (2)$$

$$\text{where Loop Gain} = \left[\frac{T_O}{R_{FB} + R_S \left(1 + \frac{R_{FB}}{R_{FF}}\right)} \right]$$

At higher gains the small value inverting input impedance causes an apparent loss in bandwidth. This can be seen from the equation:

$$f_{\text{ACTUAL BW}} \approx \left[f_{(A_V=+2)} \text{ BW} \right] \times (1.25) \quad (3)$$

$$\left[1 + \left(\frac{R_S}{R_{FB}} \right) \times \left(1 + \frac{R_{FB}}{R_{FF}} \right) \right]$$

This loss in bandwidth at high gains can be corrected without affecting stability by lowering the value of the feedback resistor from the specified value of 402Ω .

OFFSET VOLTAGE AND NOISE

The output offset is the algebraic sum of the input offset voltage and bias current errors, all with different gains to the output. The output offset for non-inverting operation is calculated by the following equation:

$$\text{Output Offset Voltage} = \pm I_{b_N} \times R_N \left(1 + \frac{R_{FB}}{R_{FF}} \right) \pm \quad (4)$$

$$V_{IO} \left(1 + \frac{R_{FB}}{R_{FF}} \right) \pm I_{b_I} \times R_{FB}$$

If all terms are divided by the gain $(1 + R_{FB}/R_{FF})$ it can be observed that the input referred offset improves as gain increases, and as R_N decreases.

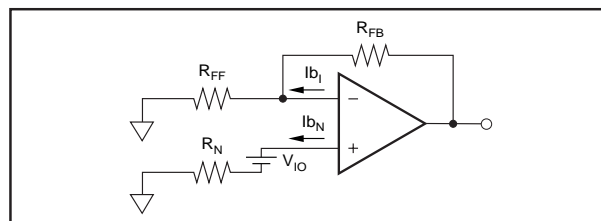

FIGURE 2. Output Offset Voltage Equivalent Circuit.

The effective noise at the output, generated by the op amp, can be determined by taking the root sum of the squares of equation (4) and applying the spectral noise values found in the Typical Performance Curve graph section. This applies to noise from the op amp only. Note that both the noise figure (NF) and the equivalent input offset voltages improve as the closed loop gain increases (by keeping R_{FB} fixed and reducing R_{FF} with $R_N = 0\Omega$).

INCREASING BANDWIDTH AT HIGH GAINS

The closed-loop bandwidth can be extended at high gains by reducing the value of the feedback resistor R_{FB} (see Equation 3). This bandwidth reduction is caused by the feedback current being split between R_S and R_{FF} (refer to Figure 1). As the gain increases (for a fixed R_{FB}), more feedback current is shunted through R_{FF} , which reduces closed-loop bandwidth.

CIRCUIT LAYOUT AND BASIC OPERATION

Achieving optimum performance with a high frequency amplifier like the OPA2658 requires careful attention to layout parasitics and selection of external components. Recommendations for PC board layout and component selection include:

a) Minimize parasitic capacitance to any ac ground for all of the signal I/O pins. Parasitic capacitance on the output and inverting input pins can cause instability; on the non-inverting input it can react with the source impedance to cause unintentional bandlimiting. To reduce unwanted capacitance, a window around the signal I/O pins should be opened in all of the ground and power planes. Otherwise, ground and power planes should be unbroken elsewhere on the board.

b) Minimize the distance ($< 0.25''$) from the two power pins to high frequency $0.1\mu\text{F}$ decoupling capacitors. At the pins, the ground and power plane layout should not be in close proximity to the signal I/O pins. Avoid narrow power and ground traces to minimize inductance between the pins and the decoupling capacitors. Larger ($2.2\mu\text{F}$ to $6.8\mu\text{F}$) decoupling capacitors, effective at lower frequencies, should also be used. These may be placed somewhat farther from the device and may be shared among several devices in the same area of the PC board.

c) Careful selection and placement of external components will preserve the high frequency performance of the OPA2658. Resistors should be a very low reactance type. Surface mount resistors work best and allow a tighter overall layout. Metal film or carbon composition axially-leaded resistors can also provide good high frequency performance. Again, keep their leads as short as possible. Never use wirewound type resistors in a high frequency application.

Since the output pin and the inverting input pin are most sensitive to parasitic capacitance, always position the feedback and series output resistor, if any, as close as possible to the package pins. Other network components, such as non-inverting input termination resistors, should also be placed close to the package.

The feedback resistor value acts as the frequency response compensation element for a current feedback type amplifier. The 402Ω used in setting the specification achieves a nominal maximally flat Butterworth response while assuming a 2pF output pin parasitic. Increasing the feedback resistor will over compensate the amplifier, rolling off the frequency response, while decreasing it will decrease phase margin, peaking up the frequency response. Note that a non-inverting, unity gain buffer application still requires a feedback resistor for stability (560Ω for SO-8, 402Ω for PDIP and 560Ω for MSOP-8).

d) Connections to other wideband devices on the board may be made with short direct traces or through on-board transmission lines. For short connections, consider the trace and the input to the next device as a lumped capacitive load. Relatively wide traces (50 to 100 mils) should be used, preferably with ground and power planes opened up around them. Estimate the total capacitive load and set R_{ISO} from the plot of recommended R_{ISO} vs capacitive load. Low parasitic loads may not need an R_{ISO} since the OPA2658 is nominally compensated to operate with a 2pF parasitic load.

If a long trace is required and the 6dB signal loss intrinsic to doubly terminated transmission lines is acceptable, implement a matched impedance transmission line using microstrip or stripline techniques (consult an ECL design handbook for microstrip and stripline layout techniques). A 50Ω environment is not necessary on board, and in fact a higher impedance environment will improve distortion as shown in the distortion vs load plot. With a characteristic impedance defined based on board material and desired trace dimensions, a matching series resistor into the trace from the output of the amplifier is used as well as a terminating shunt resistor at the input of the destination device. Remember also that the terminating impedance will be the parallel combination of the shunt resistor and the input impedance of the destination device; the total effective impedance should match the trace impedance. Multiple destination devices are best handled as separate transmission lines, each with their own series and shunt terminations.

If the 6dB attenuation loss of a doubly terminated line is unacceptable, a long trace can be series-terminated at the source end only. This will help isolate the line capacitance from the op amp output, but will not preserve signal integrity as well as a doubly terminated line. If the shunt impedance at the destination end is finite, there will be some signal attenuation due to the voltage divider formed by the series and shunt impedances.

e) Socketing a high speed part like the OPA2658 is not recommended. The additional lead length and pin-to-pin capacitance introduced by the socket creates an extremely troublesome parasitic network which can make it almost impossible to achieve a smooth, stable response. Best results are obtained by soldering the part onto the board. If socketing for the DIP package is desired, high frequency flush mount pins (e.g., McKenzie Technology #710C) can give good results.

SUPPLY VOLTAGES

The OPA2658 is nominally specified for operation using $\pm 5V$ power supplies. A 10% tolerance on the supplies, or an ECL $-5.2V$ for the negative supply, is within the maximum specified total supply voltage of 11V. Higher supply voltages can break down internal junctions possibly leading to catastrophic failure. Single supply operation is possible as long as common mode voltage constraints are observed. The common mode input and output voltage specifications can be interpreted as a required headroom to the supply voltage. Observing this input and output headroom requirement will allow non-standard or single supply operation. Figure 3 shows one approach to single-supply operation.

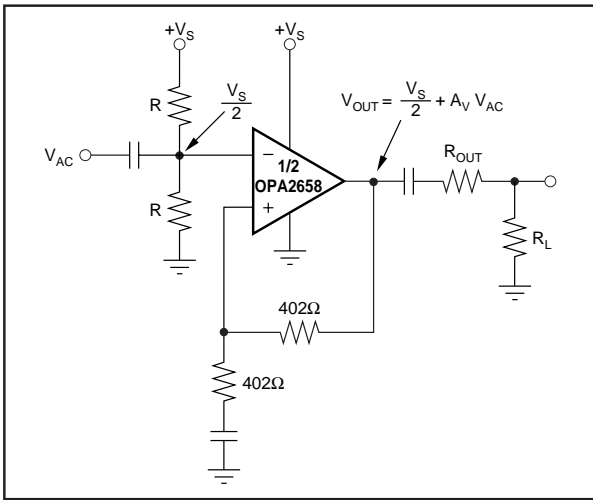

FIGURE 3. Single Supply Operation.

ESD PROTECTION

ESD static damage has been well recognized for MOSFET devices, but any semiconductor device deserves protection from this potentially damaging source. This is particularly true for very high speed, fine geometry processes.

ESD static damage can cause subtle changes in amplifier input characteristics without necessarily destroying the device. In precision operational amplifiers, this may cause a noticeable degradation of offset voltage and drift. Therefore, static protection is strongly recommended when handling the OPA2658.

OUTPUT DRIVE CAPABILITY

The OPA2658 has been optimized to drive 75Ω and 100Ω resistive loads. The device can drive 2Vp-p into a 75Ω load. This high-output drive capability makes the OPA2658 an ideal choice for a wide range of RF, IF, and video applications. In many cases, additional buffer amplifiers are unneeded.

Many demanding high-speed applications such as ADC/DAC buffers require op amps with low wideband output impedance. For example, low output impedance is essential when driving the signal-dependent capacitances at the inputs of flash A/D converters. As shown in Figure 4, the

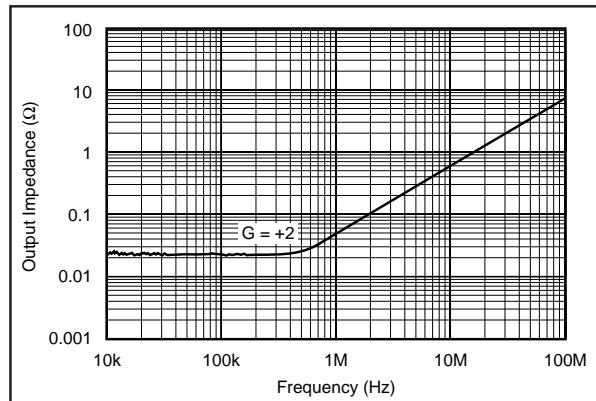

FIGURE 4. Closed-Loop Output Impedance vs Frequency.

OPA2658 maintains very low closed-loop output impedance over frequency. Closed-loop output impedance increases with frequency since loop gain decreases with frequency.

THERMAL CONSIDERATIONS

The OPA2658 will not require heatsinking under most operating conditions. Maximum desired junction temperature will set a maximum allowed internal power dissipation as described below. In no case should the maximum junction temperature be allowed to exceed $175^{\circ}C$.

The total internal power dissipation (P_D) is the sum of quiescent (P_{DQ}) and additional power dissipated in the two output stages (P_{DL1} and P_{DL2}) while delivering load power. Quiescent power is simply the specified no-load supply current for both channels times the total supply voltage across the part. P_{DL1} and P_{DL2} will depend on the required output signals and loads. For grounded resistive loads, and equal bipolar supplies, they would be at a maximum when the outputs are fixed at a voltage equal to $1/2$ either supply voltage. Under this condition, $P_{DL1} = V_S^2/(4 \cdot R_{L1})$ where R_{L1} includes feedback network loading. P_{DL2} is calculated the same way.

Note that it is the power in the output stages, and not into the loads, that determines internal power dissipation.

Operating junction temperature (T_J) is given by $T_A + P_D \theta_{JA}$, where T_A is the ambient temperature.

As an example, compute the maximum T_J for an OPA2658U where both op amps are at $G = +2$, $R_L = 100\Omega$, $R_{FB} = 402\Omega$, $\pm V_S = \pm 5V$, and at the specified maximum $T_A = +85^{\circ}C$. This gives:

$$P_{DQ} = (10V \cdot 17mA) = 170mW$$

$$P_{DL1} = P_{DL2} = \frac{(5V)^2}{4 \cdot (100\Omega \parallel 804\Omega)} = 70mW$$

$$P_D = 170mW + 2(70mW) = 310mW$$

$$T_J = 85^{\circ}C + 0.310W \cdot 125^{\circ}C/W = 124^{\circ}C$$

CAPACITIVE LOADS

The OPA2658's output stage has been optimized to drive low resistive loads. Capacitive loads, however, will decrease the amplifier's phase margin which may cause high frequency peaking or oscillations. Capacitive loads greater than 5pF should be buffered by connecting a small resistance, usually 10Ω to 35Ω, in series with the output as shown in Figure 5. This is particularly important when driving high capacitance loads such as flash A/D converters.

In general, capacitive loads should be minimized for optimum high frequency performance. Coax lines can be driven if the cable is properly terminated. The capacitance of coax cable (29pF/foot for RG-58) will not load the amplifier when the coaxial cable or transmission line is terminated with its characteristic impedance.

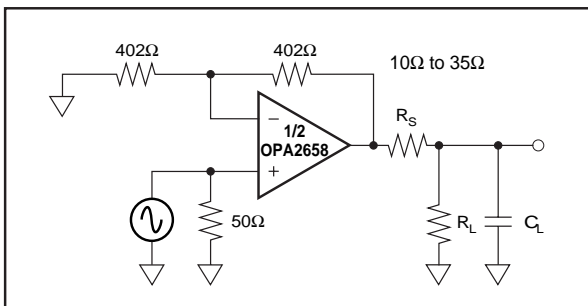

FIGURE 5. Driving Capacitive Loads.

COMPENSATION

The OPA2658 is internally compensated and is stable in unity gain with a phase margin of approximately 62°, and approximately 64° in a gain of +2V/V when used with the recommended feedback resistor value. Frequency response for other gains are shown in the Typical Performance Curves.

The high-frequency response of the OPA2658 in a good layout is very flat with frequency.

DISTORTION

The OPA2658's Harmonic Distortion characteristics into a 100Ω load are shown versus frequency and power output in the Typical Performance Curves. Distortion can be further improved by increasing the load resistance as illustrated in Figure 6. Remember to include the contribution of the feedback resistance when calculating the effective load resistance seen by the amplifier.

Narrowband communication channel requirements will benefit from the OPA2658's wide bandwidth and low intermodulation distortion on low quiescent power. If output signal power at two closely spaced frequencies is required, third-order nonlinearities in any amplifier will cause spurious power at frequencies very near the two fundamental frequencies. If the two test frequencies, f_1 and f_2 , are specified in terms of average and delta frequency, $f_O = (f_1 + f_2)/2$ and $\Delta f = |f_2 - f_1|$, the two, third-order, close-in spurious tones will appear at $f_O \pm 3 \cdot \Delta f$. The two

tone, third-order spurious plot shown in Figure 7 indicates how far below these two equal power, closely spaced, tones the intermodulation spurious will be. The single tone power is at a matched 50Ω load. The unique design of the OPA2658 provides much greater spurious free range than what a two-tone third-order intermodulation intercept specification would predict. This can be seen in Figure 7 as the spurious free range actually increases at the higher output power levels.

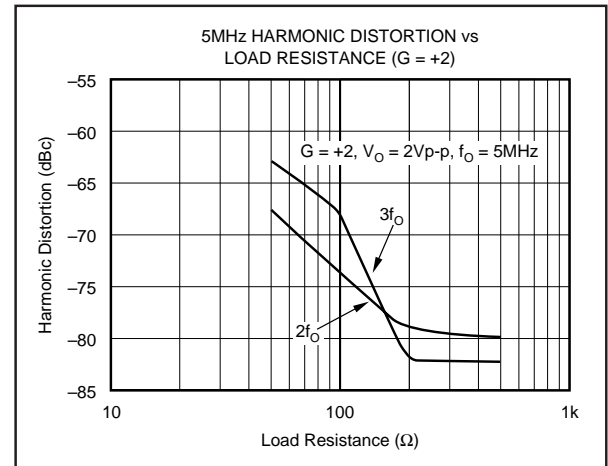

FIGURE 6. 5MHz Harmonic Distortion vs Load Resistance.

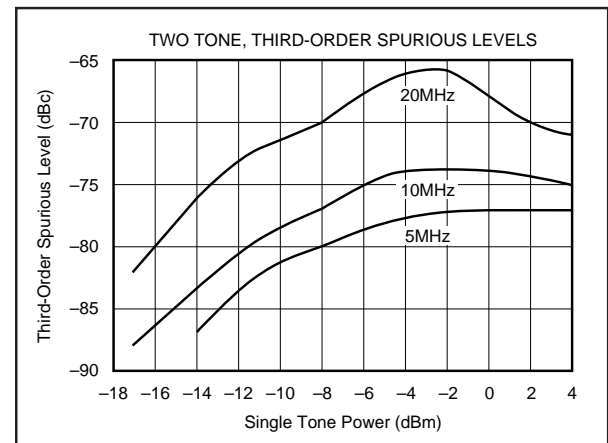

FIGURE 7. Third-Order Intercept Point vs Frequency.

CROSSTALK

Crosstalk is the undesired result of the signal of one channel mixing with and reproducing itself in the output of the other channel. Crosstalk occurs in most multichannel integrated circuits. In dual devices, the effect of crosstalk is measured by driving one channel and observing the output of the undriven channel over various frequencies. The magnitude of this effect is referenced in terms of channel- to-channel isolation and expressed in decibels. "Input referred" points to the fact that there is a direct correlation between gain and crosstalk, therefore at increased gain, crosstalk also increases by a factor equal to that of the gain. Figure 8 illustrates the measured effect of crosstalk in the OPA2658U.

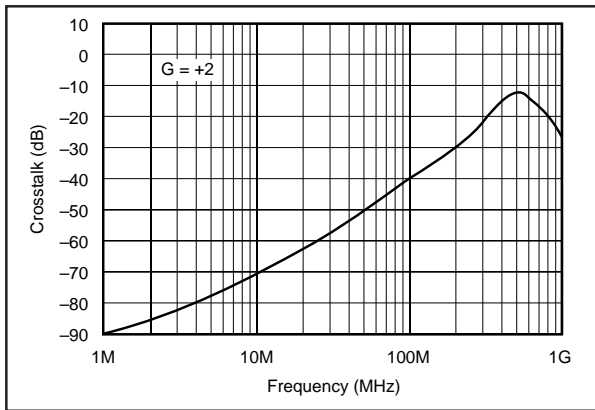

FIGURE 8. Channel-to-Channel Crosstalk.

DIFFERENTIAL GAIN AND PHASE

Differential Gain (dG) and Differential Phase (dP) are among the more important specifications for video applications. dG is defined as the percent change in closed-loop gain over a specified change in output voltage level. dP is defined as the change in degrees of the closed-loop phase over the same output voltage change. Both dG and dP are specified at the NTSC sub-carrier frequency of 3.58MHz and the PAL sub-carrier of 4.43MHz. All NTSC measurements were performed using a Tektronix model VM700A Video Measurement Set.

dG/dP of the OPA2658 were measured with the amplifier in a gain of +2V/V with 75Ω input impedance and the output back-terminated in 75Ω. The input signal selected from the generator was a 0V to 1.4V modulated ramp with sync pulse. With these conditions the test circuit shown in Figure 9 delivered a 100IRE modulated ramp to the 75Ω input of the video analyzer. The signal averaging feature of the analyzer was used to establish a reference against which the performance of the amplifier was measured. Signal averaging was also used to measure the dg and dp of the test signal in order to eliminate the generator's contribution to measured amplifier performance. Typical performance of the OPA2658 is 0.025% differential gain and 0.02° differential phase to both NTSC and PAL standards.

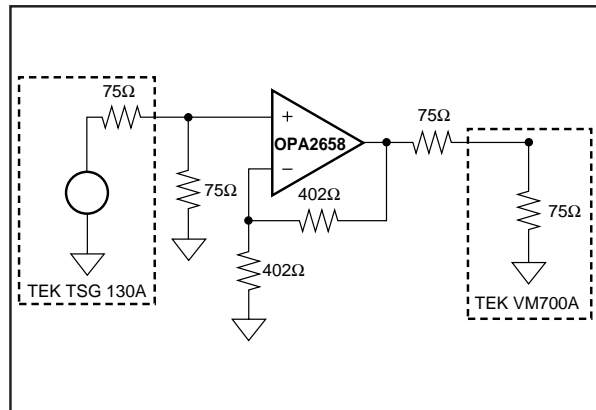

FIGURE 9. Configuration for Testing Differential Gain/Phase.

SPICE MODELS

Computer simulation using SPICE is often useful when analyzing the performance of analog circuits and systems. This is particularly true for Video and RF amplifier circuits where parasitic capacitance and inductance can have a major effect on circuit performance. SPICE models are available on a disk from the Burr-Brown Applications Department.

DEMONSTRATION BOARDS

Demonstration boards are available for each OPA2658 package style. These boards implement a very low parasitic layout that will produce the excellent frequency and pulse responses shown in the Typical Performance Curves. For each package style, the recommended demonstration board is:

DEMONSTRATION BOARD	PACKAGE	PRODUCT
DEM-OPA265xP	8-Pin DIP	OPA2658P
DEM-OPA265xU	SO-8	OPA2658U OPA2658UB
DEM-OPA26xxE	MSOP-8	OPA2658E

Contact your local Burr-Brown sales office or distributor to order demonstration boards.

TYPICAL APPLICATION

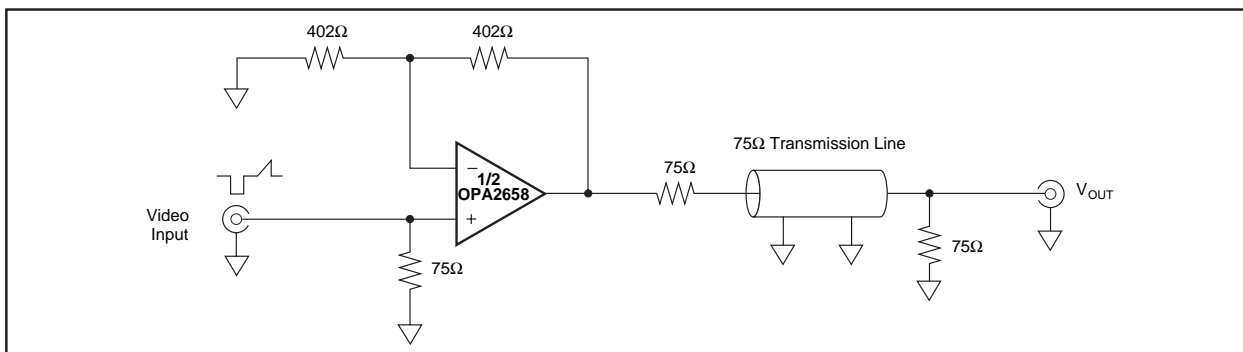

FIGURE 10. Low Distortion Video Amplifier.

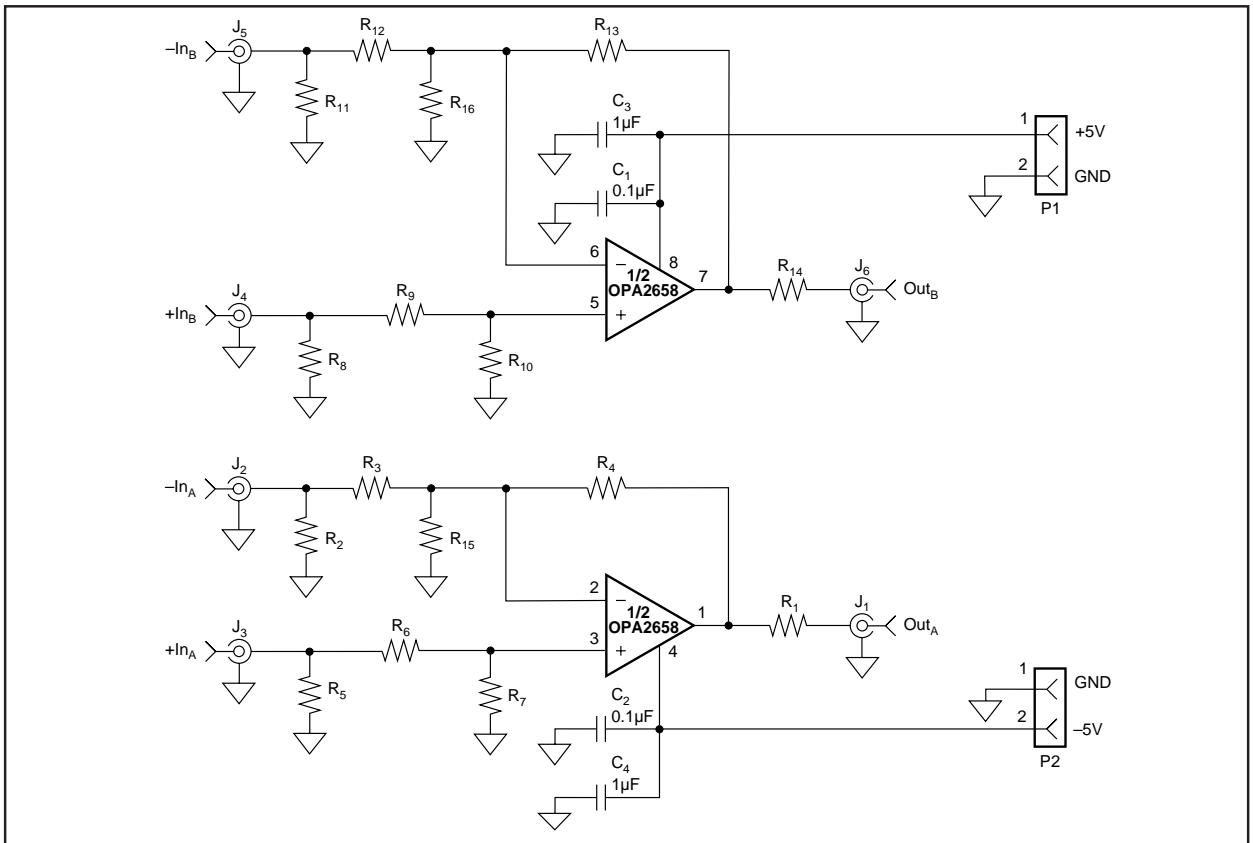

FIGURE 11. Circuit Detail For the DEM-OPA265xP Demonstration Board.

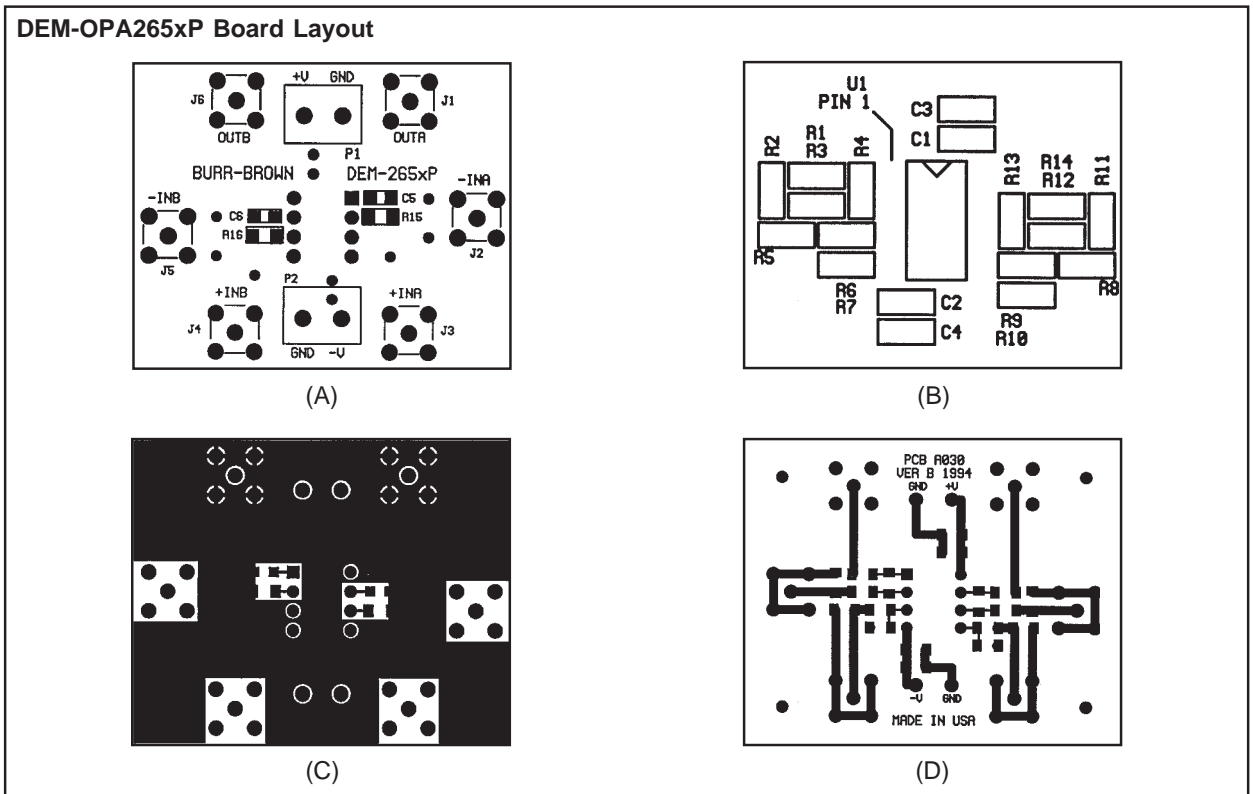

FIGURE 12a. Board Silkscreen (Bottom). 12b. Board Silkscreen (Top). 12c. Board Layout (Solder Side). 12d. Board Layout (Layout Side).