



PCM1720

## SoundPLUS™ Stereo Audio DIGITAL-TO-ANALOG CONVERTER MPEG2/AC-3 COMPATIBLE

### FEATURES

- ACCEPTS 16-, 20-, OR 24-BIT INPUT DATA
- COMPLETE STEREO DAC: Includes Digital Filter and Output Amp
- DYNAMIC RANGE: 96dB
- MULTIPLE SAMPLING FREQUENCIES:  
16kHz to 96kHz  
8X Oversampling at All Sampling Frequencies
- SYSTEM CLOCK: 256f<sub>s</sub>/384f<sub>s</sub>
- NORMAL OR I<sup>2</sup>S DATA INPUT FORMATS
- SELECTABLE FUNCTIONS:  
Soft Mute  
Digital Attenuator (256 Steps)  
Digital De-emphasis
- OUTPUT MODE: Left, Right, Mono, Mute

### DESCRIPTION

The PCM1720 is a complete low cost stereo audio digital-to-analog converter (DAC), operating off of a 256f<sub>s</sub> or 384f<sub>s</sub> system clock. The DAC contains a 3rd-order ΔΣ modulator, a digital interpolation filter, and an analog output amplifier. The PCM1720 can accept 16-, 20-, or 24-bit input data in either normal or I<sup>2</sup>S formats.

The digital filter performs an 8X interpolation function and includes selectable features such as soft mute, digital attenuation and digital de-emphasis. The PCM1720 can accept standard digital audio sampling frequencies as well as one-half and double sampling frequencies.

The PCM1720 is ideal for applications which combine compressed audio and video data such as DVD, DVD-ROM, set-top boxes and MPEG sound cards.

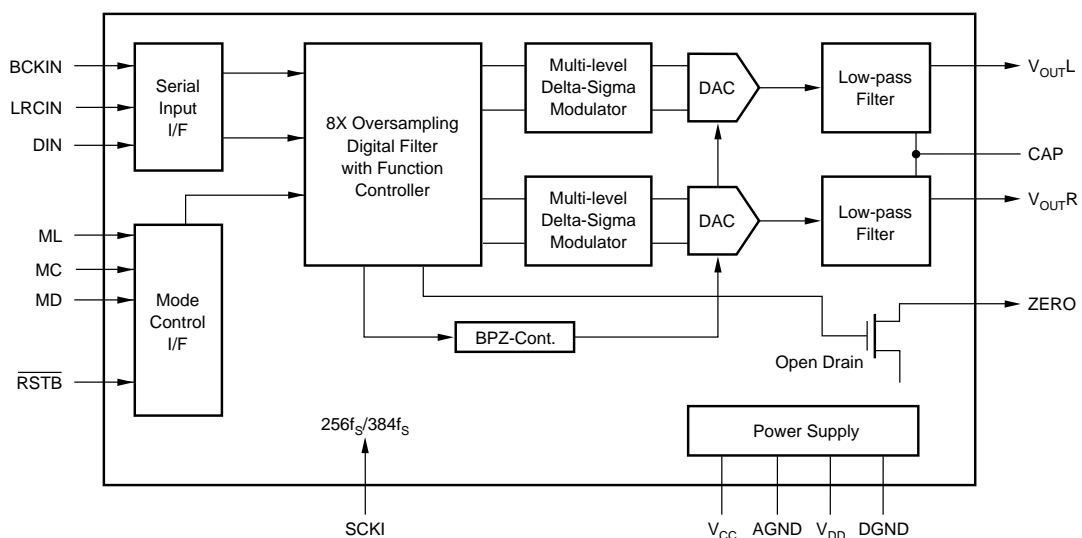

International Airport Industrial Park • Mailing Address: PO Box 11400, Tucson, AZ 85734 • Street Address: 6730 S. Tucson Blvd., Tucson, AZ 85706 • Tel: (520) 746-1111 • Twx: 910-952-1111  
Internet: <http://www.burr-brown.com/> • FAXLine: (800) 548-6133 (US/Canada Only) • Cable: BBRCORP • Telex: 066-6491 • FAX: (520) 889-1510 • Immediate Product Info: (800) 548-6132

# SPECIFICATIONS

All specifications at +25°C, +V<sub>CC</sub> = +V<sub>DD</sub> = +5V, f<sub>S</sub> = 44.1kHz, and 16-bit input data, SYSCLK = 384f<sub>S</sub>, unless otherwise noted.

PARAMETER	CONDITIONS	PCM1720			UNITS
		MIN	TYP	MAX	
<b>RESOLUTION</b>		16		24	Bits
<b>DATA FORMAT</b> Audio Data Format Data Bit Length			Standard/I <sup>2</sup> S 16/20/24 Selectable		
Sampling Frequency (f <sub>S</sub> )	Standard f <sub>S</sub>	32	44.1	48	kHz
	One-half f <sub>S</sub>	16	22.05	24	kHz
	Double f <sub>S</sub>	64	88.2	96	kHz
Internal System Clock Frequency			256f <sub>S</sub> /384f <sub>S</sub>		
<b>DIGITAL INPUT/OUTPUT LOGIC LEVEL</b>			TTL		
<b>DYNAMIC PERFORMANCE<sup>(1)</sup></b>					
THD+N at f <sub>S</sub> (0dB)	f <sub>S</sub> = 44.1kHz		-90	-80	dB
	f <sub>S</sub> = 96kHz		-88		dB
THD+N at -60dB	f <sub>S</sub> = 44.1kHz		-34		dB
	f <sub>S</sub> = 96kHz		-31		dB
Dynamic Range	f <sub>S</sub> = 44.1kHz	90	96		dB
	f <sub>S</sub> = 96kHz		93		dB
Signal-to-Noise Ratio <sup>(2)</sup>	f <sub>S</sub> = 44.1kHz	92	100		dB
	f <sub>S</sub> = 96kHz		97		dB
Channel Separation	f <sub>S</sub> = 44.1kHz	90	97		dB
<b>DC ACCURACY</b>					
Gain Error			±1.0	±5.0	% of FSR
Gain Mismatch, Channel-to-Channel			±1.0	±5.0	% of FSR
Bipolar Zero Error	V <sub>OUT</sub> = V <sub>CC</sub> /2 at BPZ		±30		mV
<b>ANALOG OUTPUT</b>					
Output Voltage	Full Scale (0dB)		0.62 x V <sub>CC</sub>		V <sub>p-p</sub>
Center Voltage			V <sub>CC</sub> /2		VDC
Load Impedance	AC Load	5			kΩ
<b>DIGITAL FILTER PERFORMANCE</b>					
Passband				0.445	f <sub>S</sub>
Stopband		0.555			f <sub>S</sub>
Passband Ripple				±0.17	dB
Stopband Attenuation		-35			dB
Delay Time			11.125/f <sub>S</sub>		sec
De-emphasis Error		-0.2		+0.55	dB
<b>INTERNAL ANALOG FILTER</b>					
-3dB Bandwidth			100		kHz
Passband Response	f = 20kHz		-0.16		dB
<b>POWER SUPPLY REQUIREMENTS</b>					
Voltage Range	V <sub>DD</sub> , V <sub>CC</sub>	4.5	5	5.5	VDC
Supply Current: I <sub>CC</sub> + I <sub>DD</sub>	V <sub>CC</sub> = V <sub>DD</sub> = 5V, f <sub>S</sub> = 44.1kHz		18	25	mA
	V <sub>CC</sub> = V <sub>DD</sub> = 5V, f <sub>S</sub> = 96kHz		25	35	mA
<b>TEMPERATURE RANGE</b>					
Operation		-25		+85	°C
Storage		-55		+100	°C

NOTES: (1) Dynamic performance specs are tested with 20kHz low pass filter and THD+N specs are tested with 30kHz LPF, 400Hz HPF, Average-Mode. (2) SNR is tested with Infinite Zero Detection off.

The information provided herein is believed to be reliable; however, BURR-BROWN assumes no responsibility for inaccuracies or omissions. BURR-BROWN assumes no responsibility for the use of this information, and all use of such information shall be entirely at the user's own risk. Prices and specifications are subject to change without notice. No patent rights or licenses to any of the circuits described herein are implied or granted to any third party. BURR-BROWN does not authorize or warrant any BURR-BROWN product for use in life support devices and/or systems.

## PIN CONFIGURATION

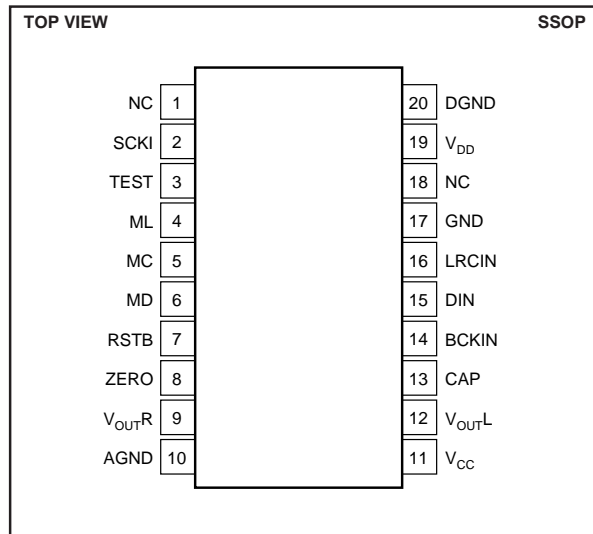

## PACKAGE INFORMATION

PRODUCT	PACKAGE	PACKAGE DRAWING NUMBER <sup>(1)</sup>
PCM1720	20-Pin SSOP	334-1

NOTE: (1) For detailed drawing and dimension table, please see end of data sheet, or Appendix C of Burr-Brown IC Data Book.

## ABSOLUTE MAXIMUM RATINGS

Power Supply Voltage .....	+6.5V
+V <sub>CC</sub> to +V <sub>DD</sub> Difference .....	±0.1V
Input Logic Voltage .....	-0.3V to (V <sub>DD</sub> + 0.3V)
Power Dissipation .....	300mW
Operating Temperature Range .....	-25°C to +85°C
Storage Temperature .....	-55°C to +125°C
Lead Temperature (soldering, 5s) .....	+260°C
Thermal Resistance, $\theta_{JA}$ .....	+70°C/W

## PIN ASSIGNMENTS

PIN	NAME	TYPE	FUNCTION
1	NC	—	No Connection.
2	SCKI	IN	System Clock Input: 256f <sub>s</sub> or 384f <sub>s</sub> .
3	TEST	OUT	Reserved for Factory Use.
4*	ML	IN	Latch Enable for Serial Control Data.
5*	MC	IN	Clock for Serial Control Data.
6*	MD	IN	Data Input for Serial Control.
7*	RSTB	IN	Reset Input. When this pin is low, the digital filters and modulators are held in reset.
8	ZERO	OUT	Zero Data Flag. This pin is low when the data is continuously zero for more than 65,535 cycles of BCKIN.
9	V <sub>OUTR</sub>	OUT	Right Channel Analog Output.
10	AGND	PWR	Analog Ground.
11	V <sub>CC</sub>	PWR	Analog Power Supply (+5V).
12	V <sub>OUTL</sub>	OUT	Left Channel Analog Output.
13	CAP	—	Common Pin for Analog Output Amplifiers.
14*	BCKIN	IN	Bit Clock for Clocking in the Audio Data.
15*	DIN	IN	Serial Audio Data Input.
16*	LRCIN	IN	Left/Right Word Clock. Frequency is equal to fs.
17	GND	PWR	Ground.
18	NC	—	No Connection.
19	V <sub>DD</sub>	PWR	Digital Power Supply (+5V). Recommended connection is to the analog power supply.
20	DGND	PWR	Digital Ground. Recommended connection is to the digital ground plane.

\* These pins include internal pull-up resistors.

## ELECTROSTATIC DISCHARGE SENSITIVITY

This integrated circuit can be damaged by ESD. Burr-Brown recommends that all integrated circuits be handled with appropriate precautions. Failure to observe proper handling and installation procedures can cause damage.

ESD damage can range from subtle performance degradation to complete device failure. Precision integrated circuits may be more susceptible to damage because very small parametric changes could cause the device not to meet its published specifications.

# TYPICAL PERFORMANCE CURVES

At  $T_A = +25^\circ\text{C}$ ,  $V_{CC} = V_{DD} = +5\text{V}$ ,  $f_S = 44.1\text{kHz}$ , 16-bit input data, unless otherwise noted. Measurement bandwidth is 20kHz

## DYNAMIC PERFORMANCE

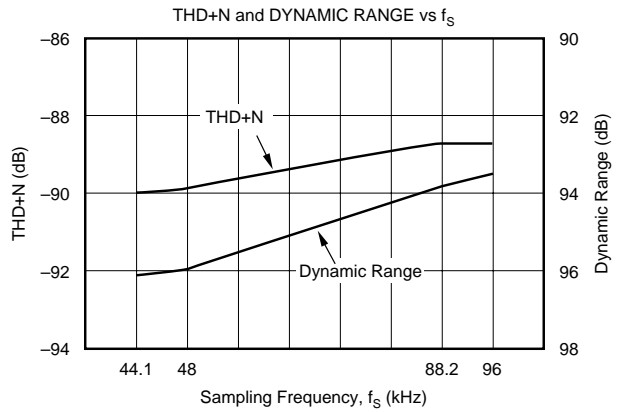
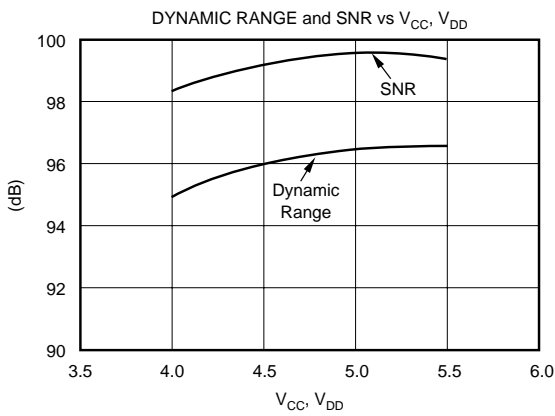
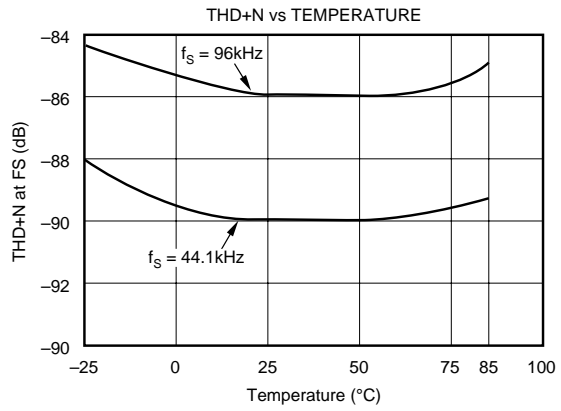
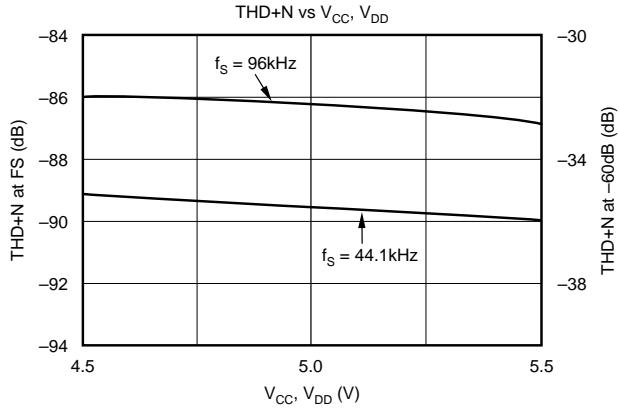

# TYPICAL PERFORMANCE CURVES

At  $T_A = +25^\circ\text{C}$ ,  $V_{CC} = V_{DD} = +5\text{V}$ ,  $R_L = 44.1\text{kHz}$ ,  $f_{\text{SYS}} = 384f_s$ , and 16-bit input data, unless otherwise noted.

## DIGITAL FILTER

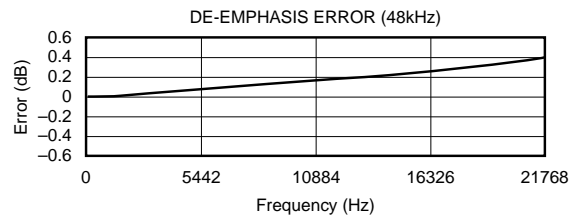
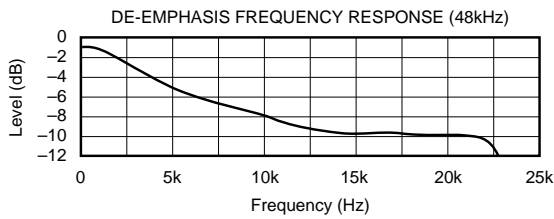
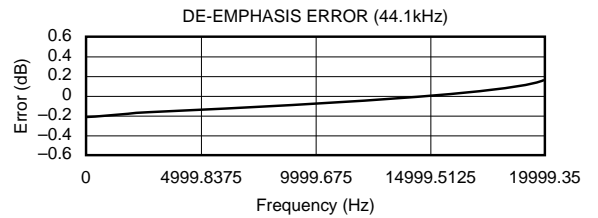
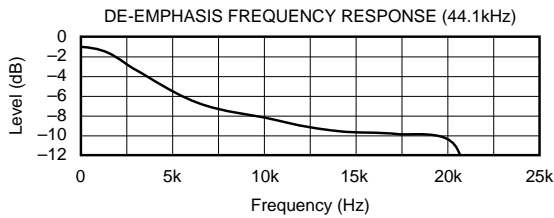
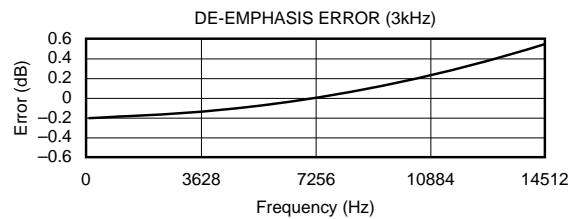
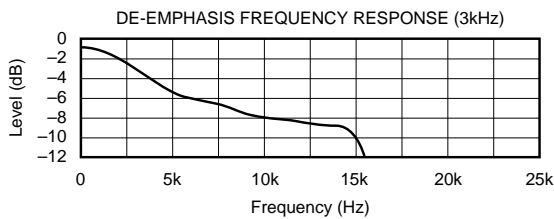
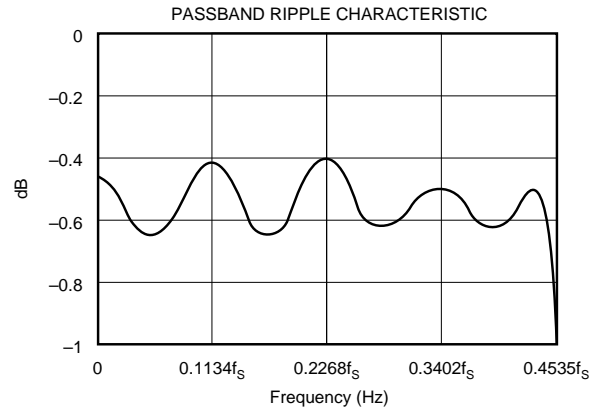
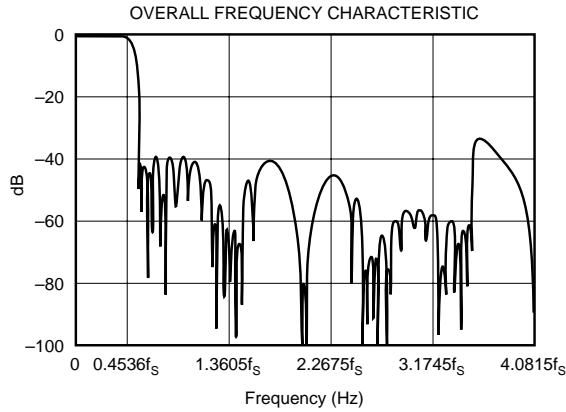

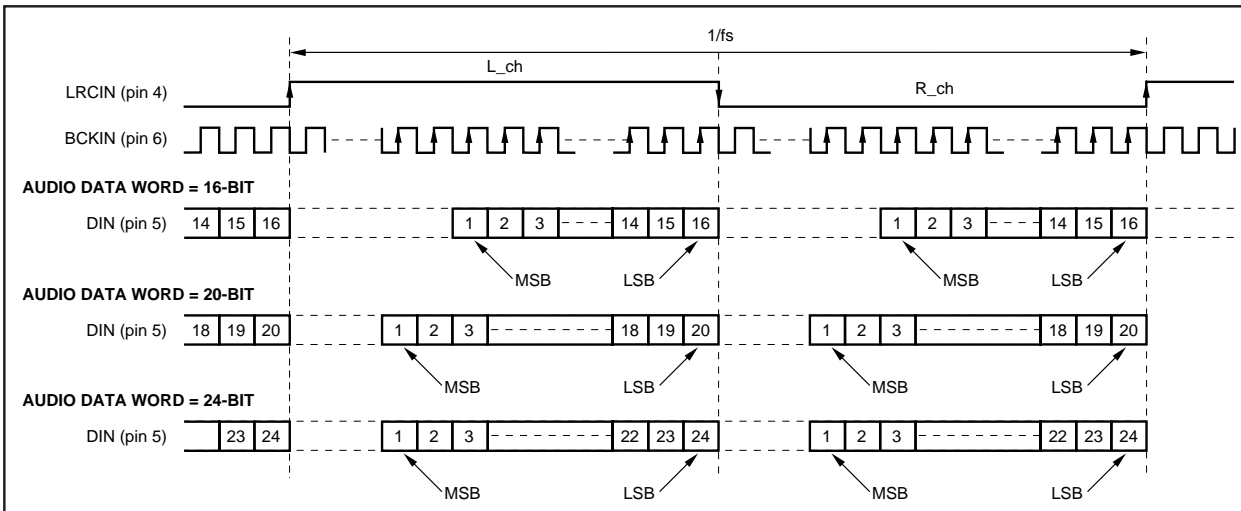

FIGURE 1. "Normal" Data Input Timing.

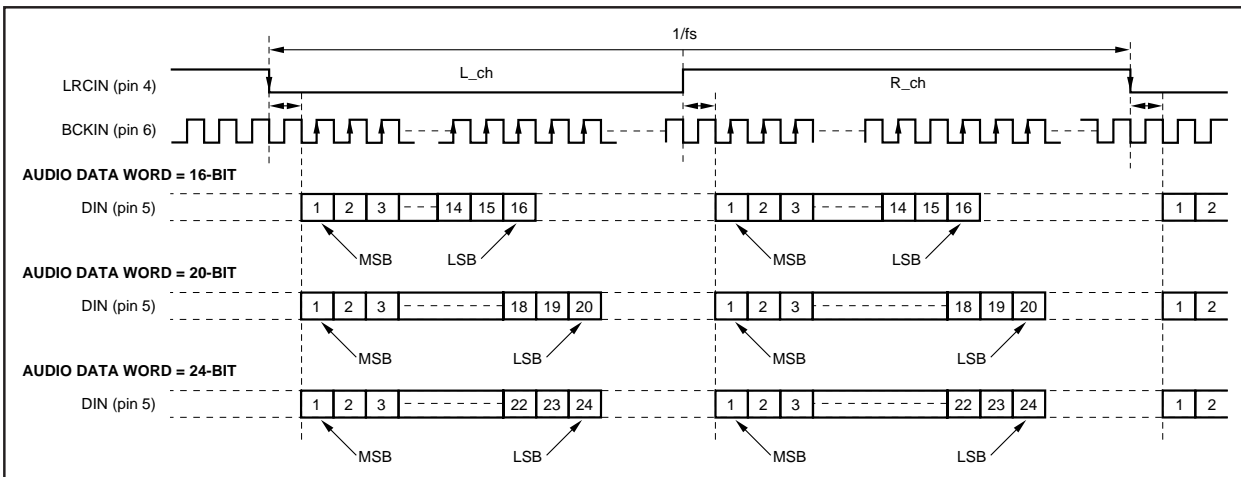

FIGURE 2. "I²S" Data Input Timing.

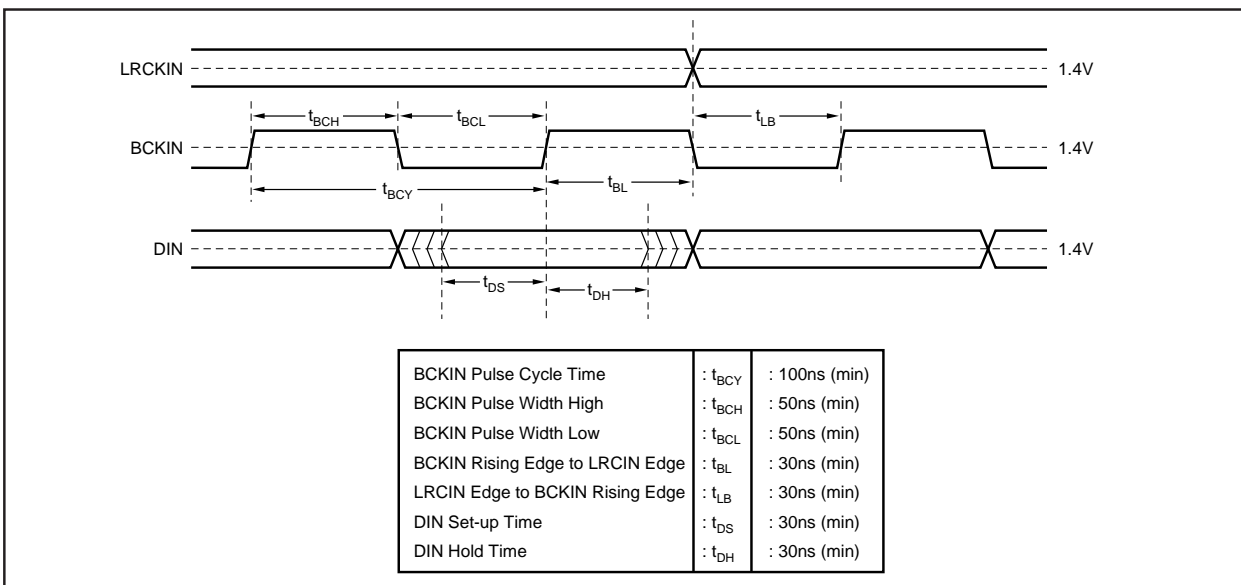

FIGURE 3. Audio Data Input Timing.

## TYPICAL CONNECTION DIAGRAM

Figure 4 illustrates the typical connection diagram for PCM1720 used in a stand-alone application.

## SYSTEM CLOCK

The system clock for PCM1720 must be either  $256f_s$  or  $384f_s$ , where  $f_s$  is the audio sampling frequency (LRCIN), typically 32kHz, 44.1kHz or 48kHz. The system clock is used to operate the digital filter and the noise shaper. The system clock input (SCKI) is at pin 2.

PCM1720 has a system clock detection circuit which automatically detects the frequency, either  $256f_s$  or  $384f_s$ . The system clock should be synchronized with LRCIN (pin 16), but PCM1720 can compensate for phase differences. If the phase difference between LRCIN and system clock is greater than  $\pm 6$  bit clocks (BCKIN), the synchronization is performed automatically. The analog outputs are forced to a bipolar zero state ( $V_{CC}/2$ ) during the synchronization function. Table I shows the typical system clock frequency inputs for the PCM1720.

SAMPLING RATE (LRCIN)	SYSTEM CLOCK FREQUENCY (MHz)	
	$256f_s$	$384f_s$
32kHz	8.192	12.288
44.1kHz	11.2896	16.9340
48kHz	12.288	18.432

TABLE I. System Clock Frequencies vs Sampling Rate.

## SPECIAL FUNCTIONS

PCM1720 includes several special functions, including digital attenuation, digital de-emphasis, soft mute, data format selection and input word resolution. These functions are controlled using a three-wire interface. MD (pin 6) is used for the program data, MC (pin 5) is used to clock in the program data, and ML (pin 4) is used to latch in the program data. Table II lists the selectable special functions.

FUNCTION	DEFAULT MODE
Input Audio Data Format Selection Normal Format I <sup>2</sup> S Format	Normal Format
Input Audio Data Bit Selection 16/20/24 Bits	16 Bits
Input LRCIN Polarity Selection Lch/Rch = High/Low Lch/Rch = Low/High	Lch/Rch = High/Low
De-emphasis Control	OFF
Soft Mute Control	OFF
Attenuation Control Lch, Rch Individually Lch, Rch Common	0dB Lch, Rch Individually Fixed
Infinite Zero Detection Circuit Control	OFF
Operation Enable (OPE)	Enabled
Sample Rate Selection Internal System Clock Selection $256f_s$ $384f_s$	$384f_s$
Sampling Frequency 44.1kHz Group 48kHz Group 32kHz Group	44.1kHz
Analog Output Mode L, R, Mono, Mute	Stereo

TABLE II. Selectable Functions.

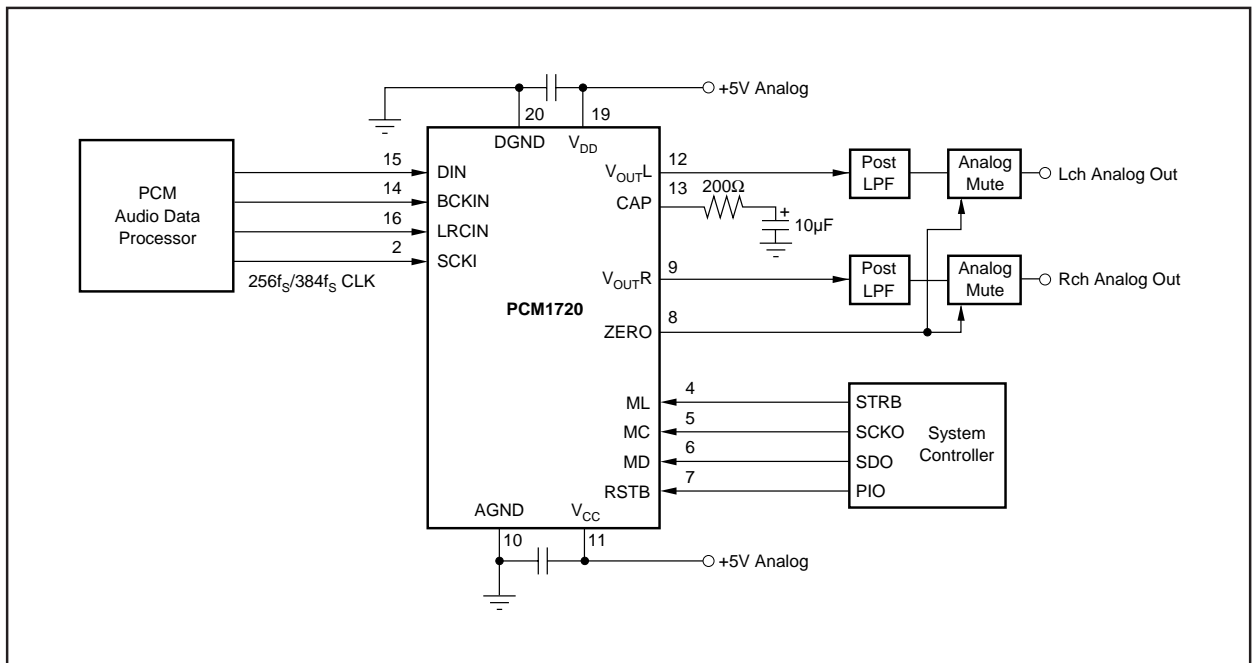

FIGURE 4. Typical Connection Diagram.

## MAPPING OF PROGRAM REGISTERS

	B15	B14	B13	B12	B11	B10	B9	B8	B7	B6	B5	B4	B3	B2	B1	B0
REGISTER 0	res	res	res	res	res	A1	A0	LDL	AL7	AL6	AL5	AL4	AL3	AL2	AL1	AL0
REGISTER 1	res	res	res	res	res	A1	A0	LDR	AR7	AR6	AR5	AR4	AR3	AR2	AR1	AR0
REGISTER 2	res	res	res	res	res	A1	A0	PL3	PL2	PL1	PL0	IW1	IW0	OPE	DEM	MUT
REGISTER 3	res	res	res	res	res	A1	A0	IZD	SF1	SF0	res	res	res	ATC	LRP	I <sup>2</sup> S

## PROGRAM REGISTER BIT MAPPING

PCM1720's special functions are controlled using four program registers which are 16 bits long. These registers are all loaded using MD. After the 16 data bits are clocked in, ML is used to latch in the data to the appropriate register. Table III shows the complete mapping of the four registers and Figure 6 illustrates the data input timing.

REGISTER NAME	BIT NAME	DESCRIPTION
Register 0	AL (7:0) LDL A (1:0) res	DAC Attenuation Data for Lch Attenuation Data Load Control for Lch Register Address Reserved
Register 1	AR (7:0) LDR A (1:0) res	DAC Attenuation Data for Rch Attenuation Data Load Control for Rch Register Address Reserved
Register 2	MUT DEM OPE IW (1:0) PL (3:0) A (1:0) res	Left and Right DACs Soft Mute Control De-emphasis Control Left and Right DACs Operation Control Input Audio Data Bit Select Output Mode Select Register Address Reserved
Register 3	I <sup>2</sup> S LRP ATC SYS SF (1:0) IZD A (1:0) res	Audio Data Format Select Polarity of LRCIN (pin 7) Select Attenuator Control System Clock Select Sampling Rate Select Infinite Zero Detection Circuit Control Register Address Reserved

TABLE III. Internal Register Mapping.

### REGISTER 0 (A1 = 0, A0 = 0)

B15	B14	B13	B12	B11	B10	B9	B8	B7	B6	B5	B4	B3	B2	B1	B0
res	res	res	res	res	A1	A0	LDL	AL7	AL6	AL5	AL4	AL3	AL2	AL1	AL0

Register 0 is used to control left channel attenuation. Bits 0 - 7 (AL0 - AL7) are used to determine the attenuation level. The level of attenuation is given by:

$$ATT = [20 \log_{10} (ATT\_DATA/255)] \text{ dB}$$

### ATTENUATION DATA LOAD CONTROL, LCH

Bit 8 (LDL) is used to simultaneously set analog outputs of Lch and Rch. An output level is controlled by AL[0:7] attenuation data when this bit is set to 1. When set to 0, an output level is not controlled and remains at the previous attenuation level. A LDR bit in Register 1 has an equivalent function as the LDL. When one of LDL or LDR is set to 1, the output level of the left and right channel is simultaneously controlled. The attenuation level is given by:

$$ATT = 20 \log (y/256) \text{ (dB)}, \text{ where } y = x, \text{ when } 0 \leq x \leq 254$$

$$y = x + 1, \text{ when } x = 255$$

X is the user-determined step number, an integer value between 0 and 255.

Example:

let x = 255

$$ATT = 20 \log \left( \frac{255+1}{256} \right) = 0 \text{ dB}$$

let x = 254

$$ATT = 20 \log \left( \frac{254}{256} \right) = -0.068 \text{ dB}$$

let x = 1

$$ATT = 20 \log \left( \frac{1}{256} \right) = -48.16 \text{ dB}$$

let x = 0

$$ATT = 20 \log \left( \frac{0}{256} \right) = -\infty$$

### REGISTER 1 (A1 = 0, A0 = 1)

B15	B14	B13	B12	B11	B10	B9	B8	B7	B6	B5	B4	B3	B2	B1	B0
res	res	res	res	res	A1	A0	LDR	AR7	AR6	AR5	AR4	AR3	AR2	AR1	AR0

Register 1 is used to control right channel attenuation. As in Register 1, bits 0 - 7 (AR0 - AR7) control the level of attenuation.



## REGISTER 2 (A1 = 1, A0 = 0)

B15	B14	B13	B12	B11	B10	B9	B8	B7	B6	B5	B4	B3	B2	B1	B0
res	res	res	res	res	A1	A0	PL3	PL2	PL1	PL0	IW1	IW0	OPE	DEM	MUTE

Register 2 is used to control soft mute, de-emphasis, operation enable, input resolution, and output format. Bit 0 is used for soft mute: a “HIGH” level on bit 0 will cause the output to be muted (this is ramped down in the digital domain, so no “click” is audible). Bit 1 is used to control de-emphasis. A “LOW” level on bit 1 disables de-emphasis, while a “HIGH” level enables de-emphasis.

Bit 2, (OPE) is used for operational control. Table IV illustrates the features controlled by OPE.

	DATA INPUT	DAC OUTPUT	SOFTWARE MODE INPUT
OPE = 1	Zero	Forced to BPZ <sup>(1)</sup>	Enabled
	Other	Forced to BPZ <sup>(1)</sup>	Enabled
OPE = 0	Zero	Controlled by IZD	Enabled
	Other	Normal	Enabled

TABLE IV. Output Enable (OPE) Function.

OPE controls the operation of the DAC: when OPE is “LOW”, the DAC will convert all non-zero input data. If the input data is continuously zero for 65, 536 cycles of BCKIN, the output will be forced to zero only if IZD is “HIGH”. When OPE is “HIGH”, the output of the DAC will be forced to bipolar zero, irrespective of any input data.

	DATA INPUT	DAC OUTPUT
IZD = 1	Zero	Forced to BPZ <sup>(1)</sup>
	Other	Normal
IZD = 0	Zero	Zero <sup>(2)</sup>
	Other	Normal

TABLE V. Infinite Zero Detection (IZD) Function.

	DATA INPUT	DAC OUTPUT	SOFTWARE MODE INPUT
RSTB = “HIGH”	Zero	Controlled by OPE and IZD	Enabled
	Other	Controlled by OPE and IZD	Enabled
RSTB = “LOW”	Zero	Forced to BPZ <sup>(1)</sup>	Disabled
	Other	Forced to BPZ <sup>(1)</sup>	Disabled

TABLE VI. Reset (RSTB) Function.

NOTE: (1)  $\Delta\Sigma$  is disconnected from output amplifier. (2)  $\Delta\Sigma$  is connected to output amplifier.

Bits 3 (IW0) and 4 (IW1) are used to determine input word resolution. PCM1720 can be set up for input word resolutions of 16, 20, or 24 bits:

Bit 4 (IW1)	Bit 3 (IW0)	Input Resolution
0	0	16-bit Data Word
0	1	20-bit Data Word
1	0	24-bit Data Word
0	0	Reserved

Bits 5, 6, 7, and 8 (PL0:3) are used to control output format. The output of PCM1720 can be programmed for 16 different states, as shown in Table VII.

PL0	PL1	PL2	PL3	Lch OUTPUT	Rch OUTPUT	NOTE
0	0	0	0	MUTE	MUTE	MUTE
0	0	0	1	MUTE	R	
0	0	1	0	MUTE	L	
0	0	1	1	MUTE	(L + R)/2	
0	1	0	0	R	MUTE	
0	1	0	1	R	R	
0	1	1	0	R	L	REVERSE
0	1	1	1	R	(L + R)/2	
1	0	0	0	L	MUTE	
1	0	0	1	L	R	STEREO
1	0	1	0	L	L	
1	0	1	1	L	(L + R)/2	
1	1	0	0	(L + R)/2	MUTE	
1	1	0	1	(L + R)/2	R	
1	1	1	0	(L + R)/2	L	
1	1	1	1	(L + R)/2	(L + R)/2	MONO

TABLE VII. Programmable Output Format.

## REGISTER 3 (A1 = 1, A0 = 1)

B15	B14	B13	B12	B11	B10	B9	B8	B7	B6	B5	B4	B3	B2	B1	B0
res	res	res	res	res	A1	A0	IZD	SF1	SF0	res	res	res	ATC	LRP	I <sup>2</sup> S

Register 3 is used to control input data format and polarity, attenuation channel control, system clock frequency, sampling frequency and infinite zero detection.

Bits 0 (I<sup>2</sup>S) and 1 (LRP) are used to control the input data format. A “LOW” on bit 0 sets the format to “Normal” (MSB-first, right-justified Japanese format) and a “HIGH” sets the format to I<sup>2</sup>S (Philips serial data protocol). Bit 1 (LRP) is used to select the polarity of LRCIN (sample rate clock). When bit 1 is “LOW”, left channel data is assumed when LRCIN is in a “HIGH” phase and right channel data is assumed when LRCIN is in a “LOW” phase. When bit 1 is “HIGH”, the polarity assumption is reversed.

Bit 2 (ATC) is used for controlling the attenuator. When bit 2 is “HIGH”, the attenuation data loaded in program Register 0 is used for both left and right channels. When bit 2 is “LOW”, the attenuation data for each register is applied separately to left and right channels.

Bits 6 (SF0) and 7 (SF1) are used to select the sampling frequency:

SF1	SF0	Sampling Frequency	
0	0	44.1kHz group	22.05/44.1/88.2kHz
0	1	48kHz group	24/48/96kHz
1	0	32kHz group	16/32/64kHz
1	1	Reserved	Not Defined

Bit 8 is used to control the infinite zero detection function (IZD).

When IZD is “LOW”, the zero detect circuit is off. Under this condition, no automatic muting will occur if the input is continuously zero. When IZD is “HIGH”, the zero detect feature is enabled. If the input data is continuously zero for 65, 536 cycles of BCKIN, the output will be immediately forced to a bipolar zero state ( $V_{CC}/2$ ). The zero detection

feature is used to avoid noise which may occur when the input is DC. When the output is forced to bipolar zero, there may be an audible click. PCM1720 allows the zero detect feature to be disabled so the user can implement external muting circuit.

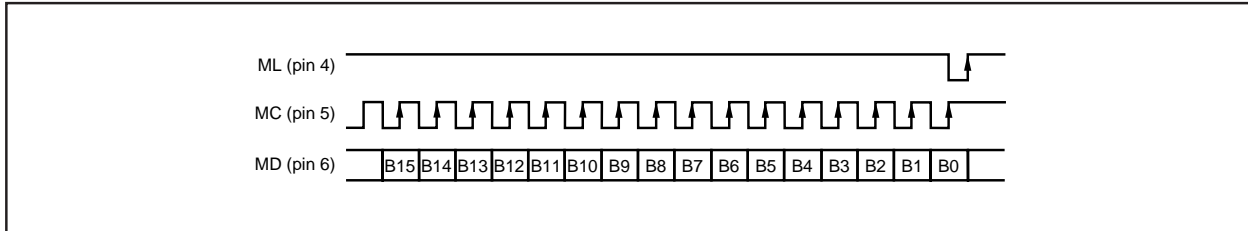

FIGURE 5. Serial Interface Timing.

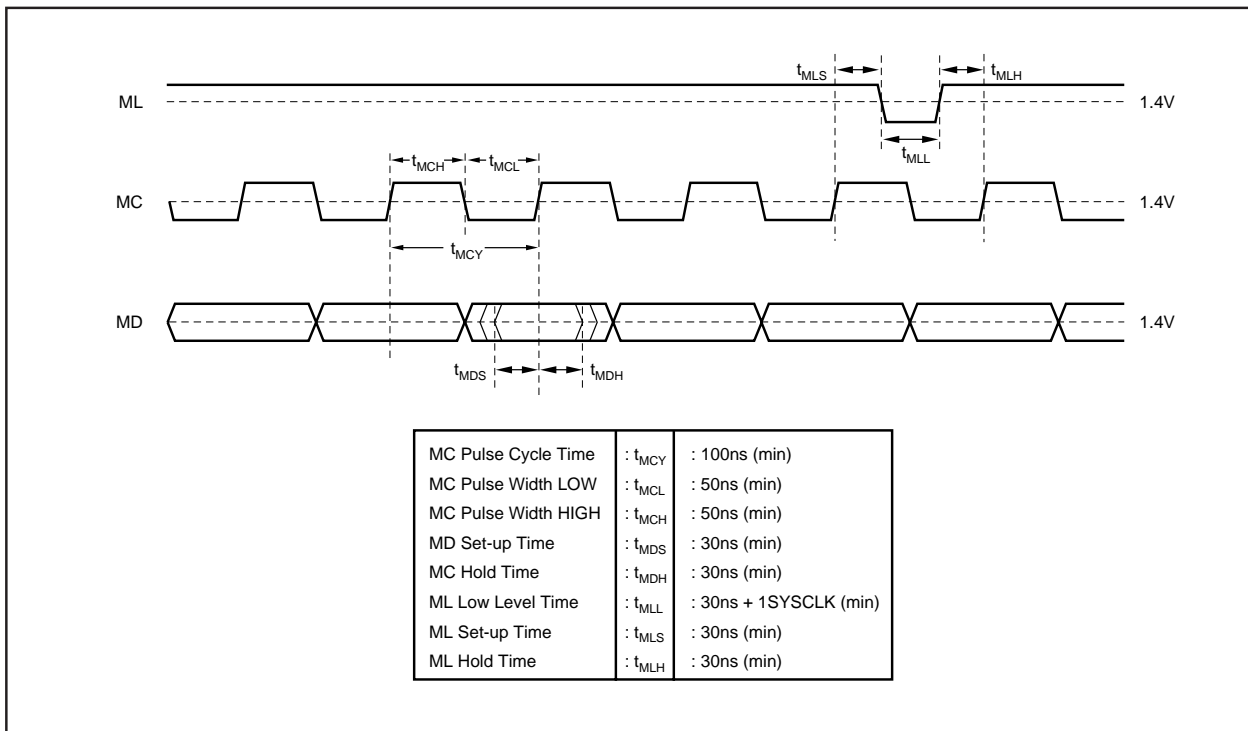

FIGURE 6. Program Register Input Timing.

# APPLICATION CONSIDERATIONS

## DELAY TIME

There is a finite delay time in delta-sigma converters. In A/D converters, this is commonly referred to as latency. For a delta-sigma D/A converter, delay time is determined by the order number of the FIR filter stage, and the chosen sampling rate. The following equation expresses the delay time of PCM1720:

$$T_D = 11.125 \times 1/f_s$$

For  $f_s = 44.1\text{kHz}$ ,  $T_D = 11.125/44.1\text{kHz} = 251.4\mu\text{s}$

Applications using data from a disc or tape source, such as CD audio, CD-Interactive, Video CD, DAT, Minidisc, etc., generally are not affected by delay time. For some professional applications such as broadcast audio for studios, it is important for total delay time to be less than 2ms.

## OUTPUT FILTERING

For testing purposes all dynamic tests are done on the PCM1720 using a 20kHz low pass filter. This filter limits the measured bandwidth for THD+N, etc. to 20kHz. Failure to use such a filter will result in higher THD+N and lower SNR and Dynamic Range readings than are found in the specifications. The low pass filter removes out of band noise. Although it is not audible, it may affect dynamic specification numbers.

The performance of the internal low pass filter from DC to 24kHz is shown in Figure 7. The higher frequency rolloff of the filter is shown in Figure 8. If the user's application has the PCM1720 driving a wideband amplifier, it is recommended to use an external low pass filter. A simple 3rd-order filter is shown in Figure 9. For some applications, a passive RC filter or 2nd-order filter may be adequate.

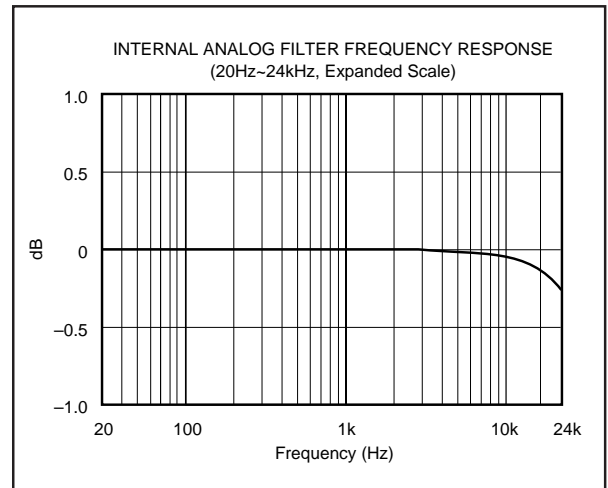

FIGURE 7. Low Pass Filter Frequency Response.

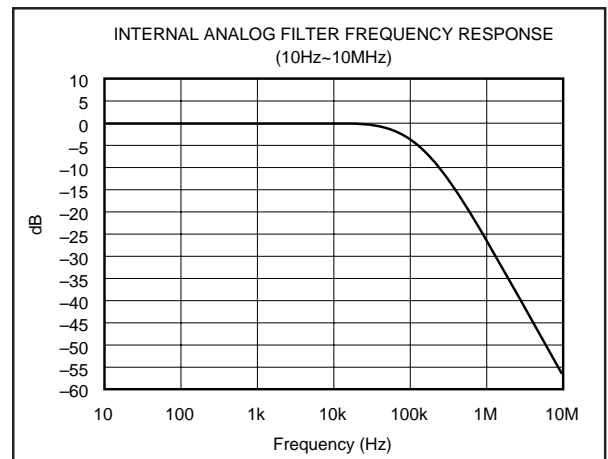

FIGURE 8. Low Pass Filter Wideband Frequency Response.

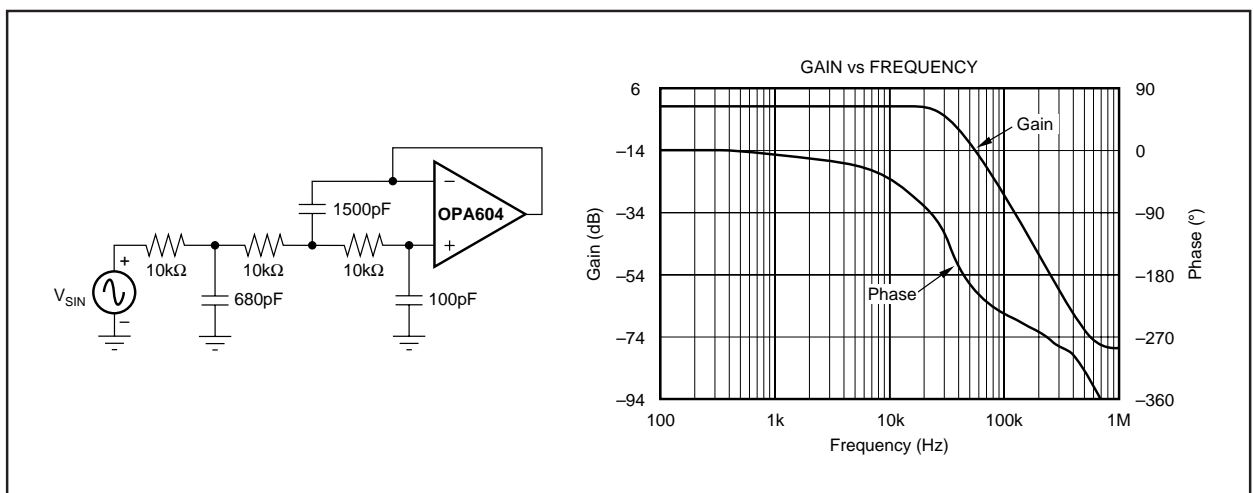

FIGURE 9. 3rd-Order LPF.

## POWER SUPPLY CONNECTIONS

PCM1720 has two power supply connections: digital ( $V_{DD}$ ) and analog ( $V_{CC}$ ). Each connection also has a separate ground. If the power supplies turn on at different times, there is a possibility of a latch-up condition. To avoid this condition, it is recommended to have a common connection between the digital and analog power supplies. If separate supplies are used without a common connection, the delta between the two supplies during ramp-up time must be less than 0.6V.

An application circuit to avoid a latch-up condition is shown in Figure 10.

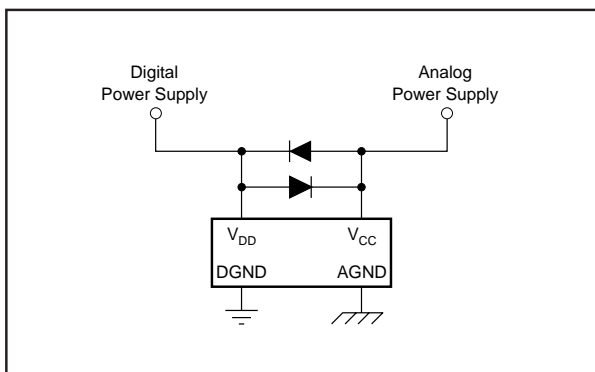

FIGURE 10. Latch-up Prevention Circuit.

## BYPASSING POWER SUPPLIES

The power supplies should be bypassed as close as possible to the unit. Refer to Figure 13 for optimal values of bypass capacitors. It is also recommended to include a 0.1 $\mu$ F ceramic capacitor in parallel with the 10 $\mu$ F tantalum capacitor.

## THEORY OF OPERATION

The delta-sigma section of PCM1720 is based on a 5-level amplitude quantizer and a 3rd-order noise shaper. This section converts the oversampled input data to 5-level delta-sigma format. A block diagram of the 5-level delta-sigma modulator is shown in Figure 11. This 5-level delta-sigma modulator has the advantage of stability and clock jitter over the typical one-bit (2-level) delta-sigma modulator.

The combined oversampling rate of the delta-sigma modulator and the internal 8X interpolation filter is  $48f_s$  for a  $384f_s$  system clock, and  $64f_s$  for a  $256f_s$  system clock. The theoretical quantization noise performance of the 5-level delta-sigma modulator is shown in Figure 12.

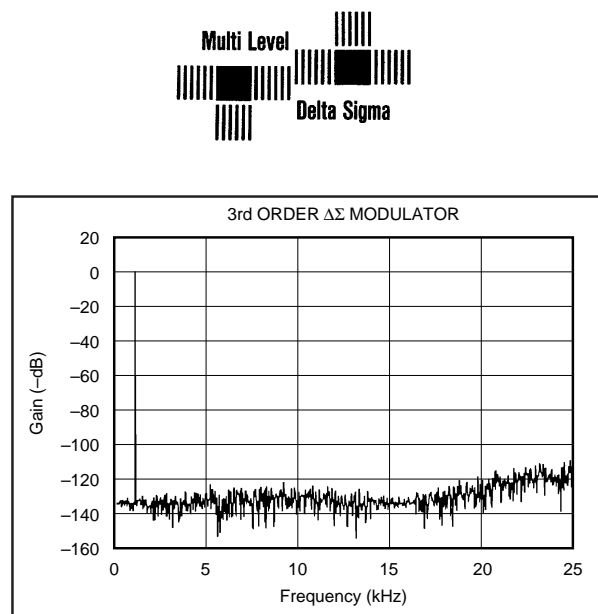

FIGURE 12. Quantization Noise Spectrum.

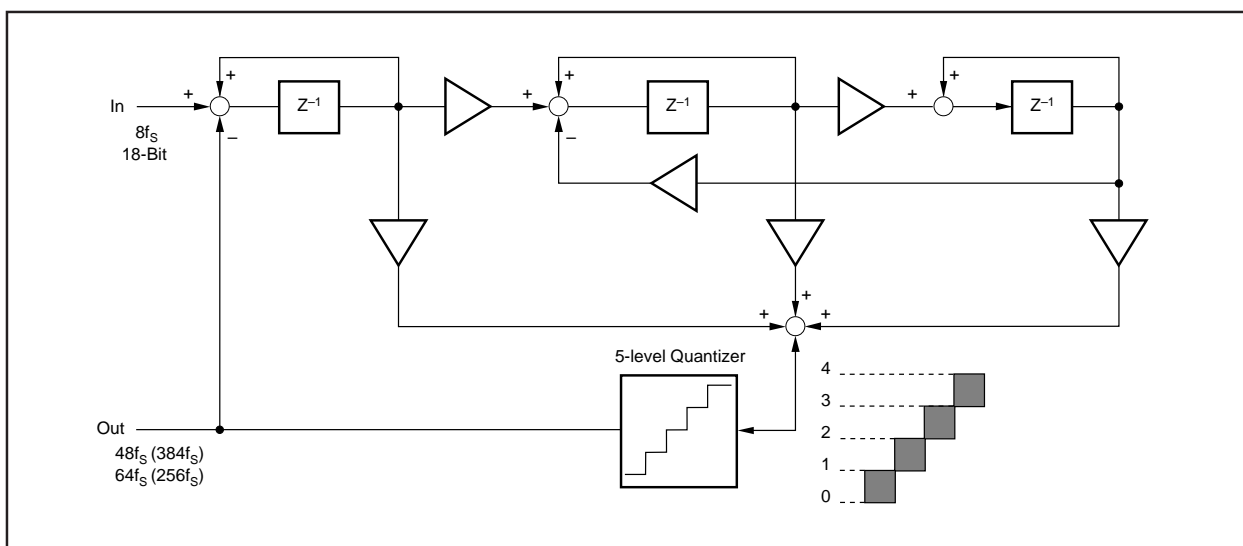

FIGURE 11. 5-Level  $\Delta\Sigma$  Modulator Block Diagram.

## AC-3 APPLICATION

Figure 13 shows the typical circuit diagram for Dolby AC-3, 5.1 channel system.

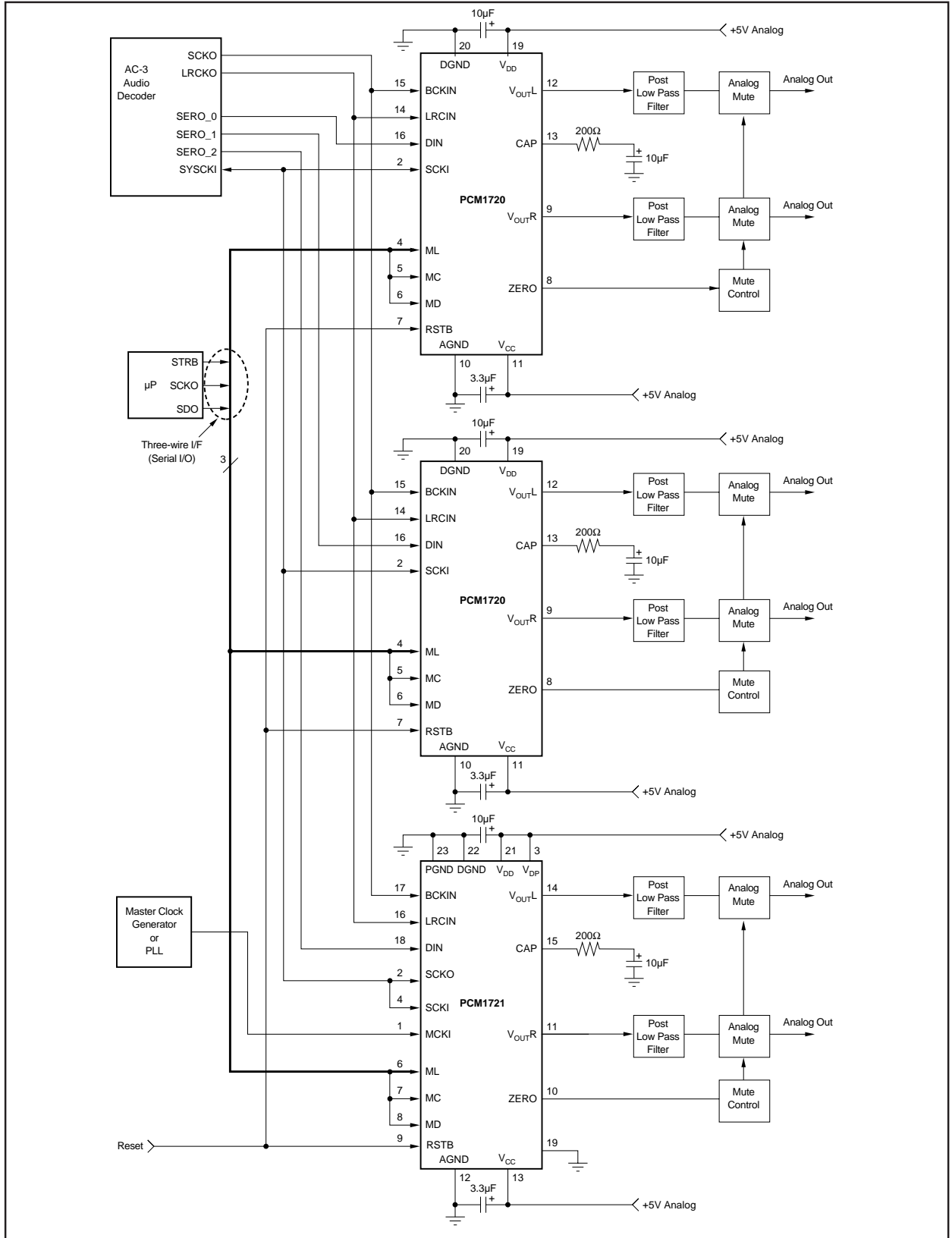

FIGURE 13. Connection Diagram for a 6-Channel AC-3 Application.