

PCM1750P
PCM1750U

Dual CMOS 18-Bit Monolithic Audio ANALOG-TO-DIGITAL CONVERTER

FEATURES

- DUAL 18-BIT LOW-POWER CMOS AUDIO A/D CONVERTER
- FAST 4.5 μ s MIN CONVERSION TIME INCLUDING S/H
- VERY LOW MAX THD+N: -88dB Without External Adjust
- COMPLETE WITH INTERNAL REFERENCE AND DUAL S/H FUNCTION
- TWO CO-PHASE SAMPLED, ± 2.75 V AUDIO INPUTS
- CAPABLE OF 4X PER CHANNEL OVERSAMPLING RATE
- RUNS ON ± 5 V SUPPLIES AND DISSIPATES 300mW MAX
- COMPACT 28-PIN PLASTIC DIP OR SOIC

DESCRIPTION

The PCM1750 is a low cost, dual 18-bit CMOS analog-to-digital converter optimized for dynamic signal applications. The PCM1750 features true co-phased inputs with an internal sample/hold function for each channel. The PCM1750 also comes complete with an internal reference. Total power dissipation is less than 300mW max using ± 5 V voltage supplies. Low maximum Total Harmonic Distortion + Noise (-88dB max) is 100% tested. The very fast PCM1750 is capable of 4X x audio bandwidth oversampling rates on both input channels simultaneously, providing greater freedom to designers in selecting input anti-aliasing filters.

PCM1750 outputs serial data in a format that is compatible with many digital filter chips and comes packaged in a space saving 28-pin plastic DIP or SOIC.

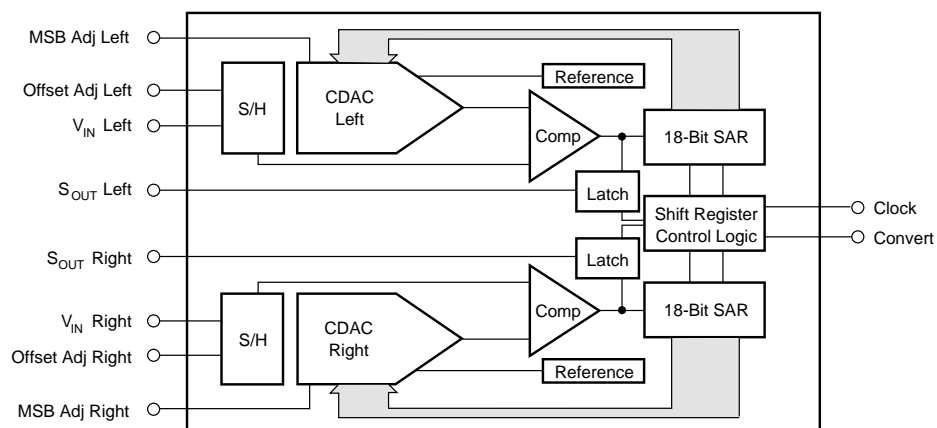

International Airport Industrial Park • Mailing Address: PO Box 11400 • Tucson, AZ 85734 • Street Address: 6730 S. Tucson Blvd. • Tucson, AZ 85706
Tel: (520) 746-1111 • Twx: 910-952-1111 • Cable: BBRCORP • Telex: 066-6491 • FAX: (520) 889-1510 • Immediate Product Info: (800) 548-6132

SPECIFICATIONS

ELECTRICAL

At 25°C, and $\pm V_A = \pm 5.0V$; $+V_D = +5.0V$, unless otherwise noted. Where relevant, specifications apply to both left and right input/output channels.

PARAMETER	CONDITIONS	PCM1750P, U			UNITS
		MIN	TYP	MAX	
RESOLUTION		18			Bits
DYNAMIC RANGE	THD + N at -60dB Referred to Full Scale	+88	+90		dB
ANALOG INPUT					
Input Range			± 2.75		V
Input Capacitance			20		pF
Aperture Delay			10		ns
Aperture Uncertainty (Jitter)			50		ps _{rms}
Full Power Input Bandwidth			500		kHz
DIGITAL INPUT/OUTPUT					
Logic Family		CMOS Compatible			
Logic Level: V_{IH}	$I_{IH} = \pm 5\mu A$	+3.5		$+V_D + 0.3$	V
V_{IL}	$I_{IL} = \pm 5\mu A$	-0.3		+1.5	V
V_{OH}	$I_{SOURCE} = 1.0mA$	+2.7	+4.7		V
V_{OL}	$I_{SINK} = 3.2mA$		+0.2	+0.4	V
Output Data Format		Serial, MSB First, BTC ⁽¹⁾			
Convert Command			Positive Edge		
Convert Command Pulse Width			81		ns
Conversion Time	Throughput Including Sample/Hold ⁽²⁾	4.5	5.2	20.8	μs
DYNAMIC CHARACTERISTICS (20Hz to 24kHz; 4X data decimated to 1X)					
Signal-to-Noise Ratio ⁽³⁾	$f_s = 192kHz^{(4)}$; $f_{IN} = 1kHz$ (0dB) ⁽⁵⁾	+88	+90		dB ⁽⁶⁾
Total Harmonic Distortion + N ⁽⁷⁾	Without External Adjustments				
$f_{IN} = 1kHz$ (0dB)	$f_s = 192kHz$		-90	-88	dB
$f_{IN} = 1kHz$ (-20dB)	$f_s = 192kHz$		-70	-68	dB
$f_{IN} = 1kHz$ (-60dB)	$f_s = 192kHz$		-30	-28	dB
Channel Separation	$f_s = 192kHz$; $f_{IN} = 1kHz$ (0dB) and 0V	+96	+108		dB
ACCURACY					
Gain Error			± 2	± 5	%
Gain Mismatch	Channel to Channel		± 0.5	± 2.0	%
BPZ (Bipolar Zero) Error ⁽⁸⁾			± 2		mV
BPZ Error Mismatch	Channel to Channel		± 3		mV
BPZ Differential Linearity Error ⁽⁹⁾			± 0.002		% of FSR ⁽¹⁰⁾
Linearity Error			± 0.003		% of FSR
Warm-up Time			1		ms
DRIFT (With Internal Reference)					
Gain	0°C to 70°C		± 50		ppm/°C
Bipolar Zero	0°C to 70°C		± 10		ppm of FSR/°C
DRIFT (Exclusive of Internal Reference)					
Gain	0°C to 70°C		± 10		ppm/°C
Bipolar Zero	0°C to 70°C		± 3		ppm of FSR/°C
REFERENCE					
V_{REF} Output (Pins 19, 24):					
Voltage			+2.75		V
Current			± 100		μA
Impedance			0.2		Ω
Accuracy			± 25		mV
Drift	0°C to 70°C		± 50		ppm/°C
V_{REF} Input (Pins 18, P25):					
Impedance ⁽¹¹⁾			363 120		Ω pF
POWER SUPPLY REJECTION	% of V_{IN} / % of V_{SUPPLY} ⁽¹²⁾		0.03		% / %
POWER SUPPLY REQUIREMENTS					
$\pm V_A$ Supply Voltage Range		± 4.75	± 5.00	± 5.25	V
$+V_D$ Supply Voltage Range		+4.75	+5.00	+5.25	V
$+I_A$; $+I_D$ Combined Supply Current	$+V_A$; $+V_D = +5.0V$		+28		mA
$-I_A$ Supply Current	$-V_A = -5.0V$		-13		mA
Power Dissipation	$\pm V_A = \pm 5.0V$; $+V_D = +5.0V$		210	300	mW
TEMPERATURE RANGE					
Specification		0		+70	°C
Operating		-40		+85	°C
Storage		-60		+100	°C

NOTES: (1) Binary Two's Complement coding. (2) The PCM1750 is tested and guaranteed at 5.2 μs , however it will operate at 4.5 μs . The dynamic performance is not guaranteed or tested at this conversion rate. (3) Ratio of $Signal_{RMS} / (Distortion_{RMS} + Noise_{RMS})$. (4) A/D converter sample frequency (4 x 48kHz; 4X oversampling per channel). (5) A/D converter input frequency (signal level). (6) Referred to input signal level. (7) Ratio of $(Distortion_{RMS} + Noise_{RMS}) / Signal_{RMS}$. (8) Externally adjustable to zero error. (9) Differential non-linearity error at bipolar major carry input code. Externally adjustable to zero error. (10) Full scale range (5.50V). (11) Refer to equivalent circuit in Figure 1. (12) Worst case operating condition. Refer to typical performance curves.



PCM1750

PIN ASSIGNMENTS

PIN	DESCRIPTION	MNEMONIC
1	-5V Analog Supply Voltage	-V _A
2	+5V Analog Supply Voltage	+V _A
3	Serial Output (Left Channel)	SOUTL
4	External Clock Input	CLK
5	+5V Analog Supply Voltage	+V _A
6	+5V Digital Voltage Supply	+V _D
7	+5V Digital Voltage Supply	+V _D
8	Digital Common Connection	DCOM
9	Analog Common Connection	ACOM
10	Digital Common Connection	DCOM
11	Convert Command Input	CONVERT
12	Serial Output (Right Channel)	SOUTR
13	+5V Analog Supply Voltage	+V _A
14	-5V Analog Supply Voltage	-V _A
15	Offset Adjust (Right Channel)	OFF _{ADJR}
16	MSB Adjust (Right Channel)	MSB _{ADJR}
17	Analog Voltage Input (Right Channel; ±2.75V)	V _{INR}
18	Reference Voltage Input (Right Channel)	VREF _{INR}
19	Reference Voltage Output (Right Channel)	VREF _{OUTR}
20	Analog Common Connection	ACOM
21	Reference Voltage Decouple	VREF _{CAP}
22	Reference Common Connection	RCOM
23	Analog Common Connection	ACOM
24	Reference Voltage Output (Left Channel)	VREF _{OUTL}
25	Reference Voltage Input (Left Channel)	VREF _{INL}
26	Analog Voltage Input (Left Channel; ±2.75V)	V _{INL}
27	MSB Adjust (Left Channel)	MSB _{ADJL}
28	Offset Adjust (Left Channel)	OFF _{ADJL}

ABSOLUTE MAXIMUM RATINGS

Analog Input Voltage (V _{IN})	-V _A -0.3V to +V _A + 0.3V
+V _A ; +V _D to ACOM/DCOM	0 to +7V
-V _A to ACOM/DCOM	0 to -7V
-V _A to +V _A ; +V _D	0 to +14V
ACOM to DCOM	±1V
Digital Inputs (pins 4, 11) to DCOM	-0.3V to +V _D + 0.3V
Power Dissipation	400mW
Lead Temperature, (soldering 10s)	+300°C
Max Junction Temperature	165°C
Thermal Resistance, θ_{JA} : Plastic DIP	80°C/W
Thermal Resistance, θ_{JA} : Plastic SOIC	100°C/W

NOTE: Stresses above those listed under Absolute Maximum Ratings may cause permanent damage to the device. Exposure to absolute maximum conditions for extended periods may affect device reliability.

PACKAGE INFORMATION

MODEL	PACKAGE	PACKAGE DRAWING NUMBER ⁽¹⁾
PCM1750P	28-Pin Plastic DIP	215
PCM1750U	28-Pin Plastic SOIC	217

NOTE: (1) For detailed drawing and dimension table, please see end of data sheet, or Appendix D of Burr-Brown IC Data Book.

TYPICAL PERFORMANCE CURVES

At 25°C, and ±V_A = ±5.0V; +V_D = +5V, unless otherwise noted. Where relevant, specifications apply to both left and right input output channels.

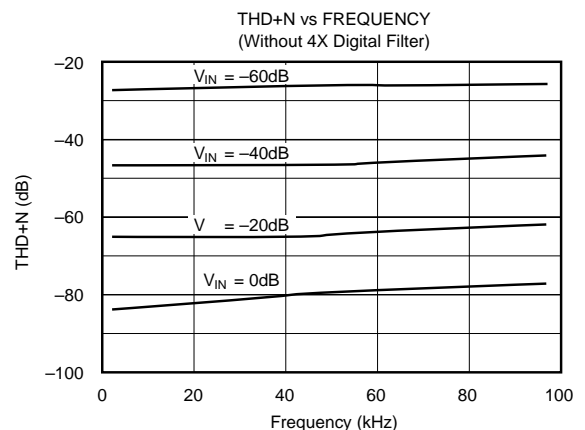
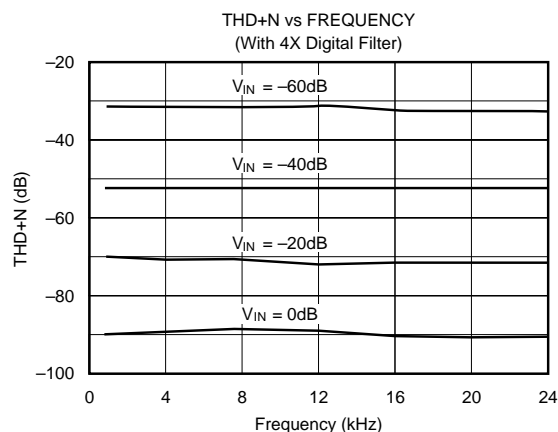

The information provided herein is believed to be reliable; however, BURR-BROWN assumes no responsibility for inaccuracies or omissions. BURR-BROWN assumes no responsibility for the use of this information, and all use of such information shall be entirely at the user's own risk. Prices and specifications are subject to change without notice. No patent rights or licenses to any of the circuits described herein are implied or granted to any third party. BURR-BROWN does not authorize or warrant any BURR-BROWN product for use in life support devices and/or systems.

TYPICAL PERFORMANCE CURVES (CONT)

At 25°C, and $\pm V_A = \pm 5.0V$; $+V_D = +5.0V$, unless otherwise noted. Where relevant, specifications apply to both left and right input-output channels.

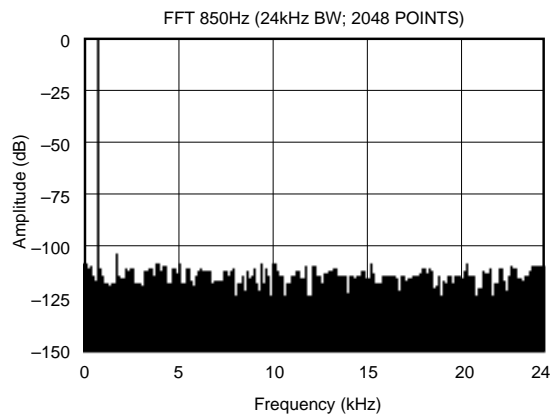
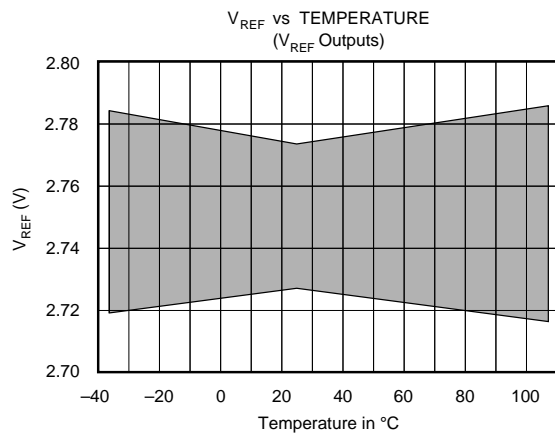
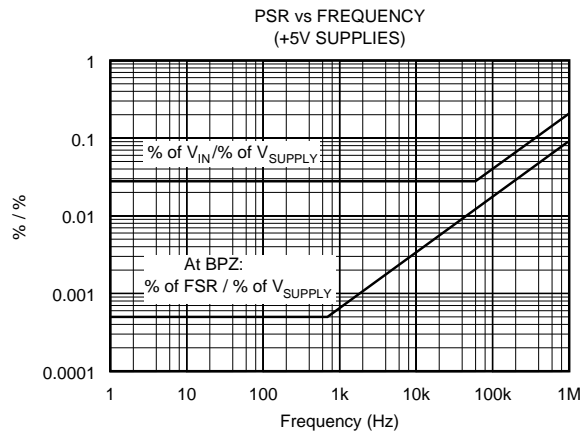
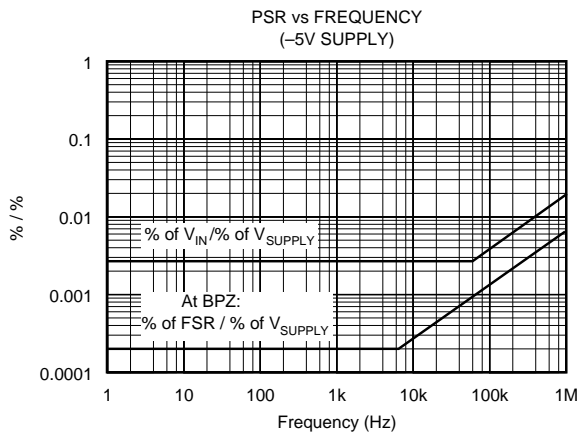
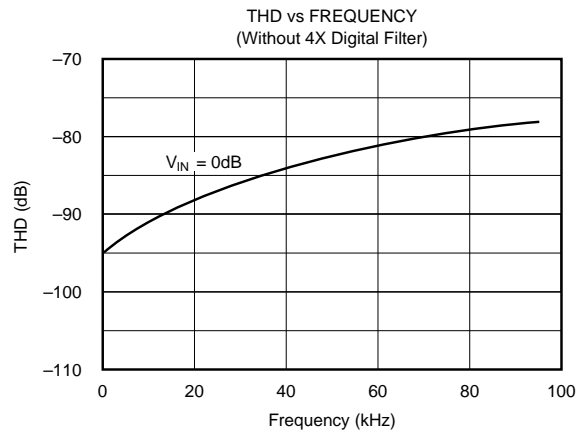
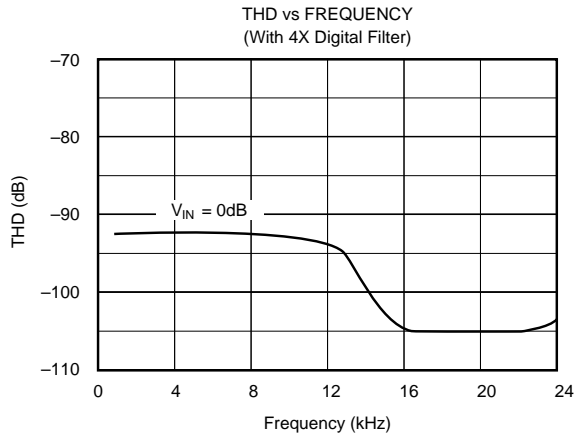

TYPICAL PERFORMANCE CURVES (CONT)

At 25°C, and $\pm V_A$; $+V_D = \pm 5V$, unless otherwise noted. Where relevant, specifications apply to both left and right input-output channels.

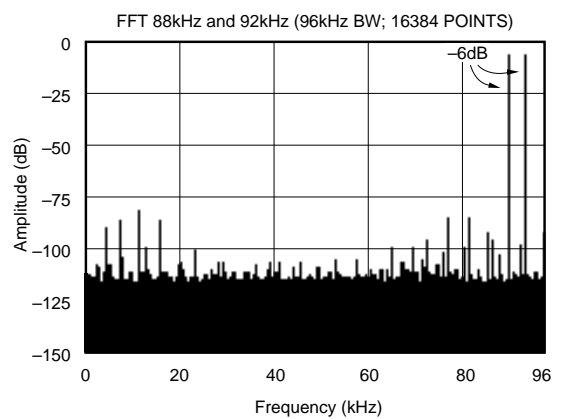
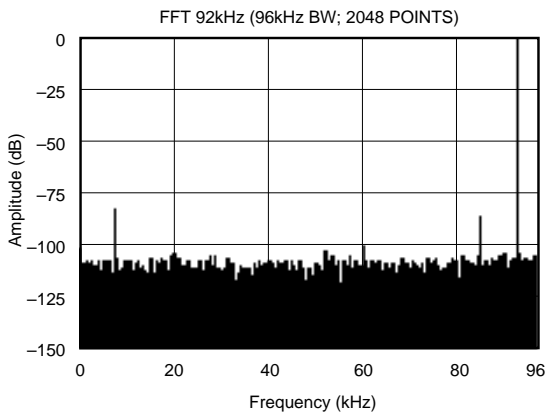
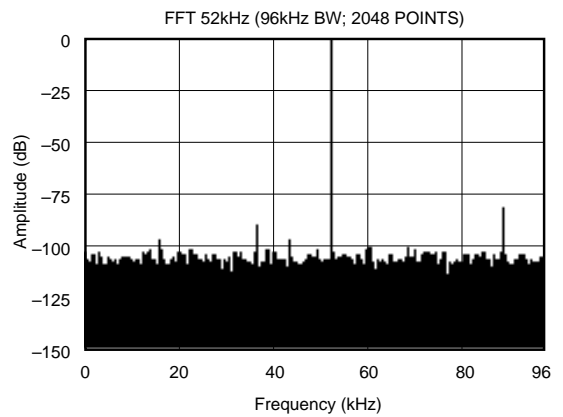
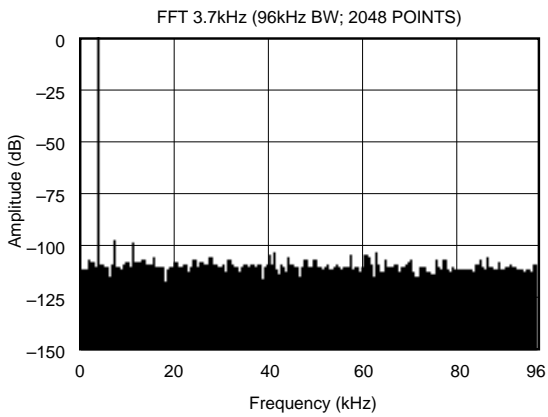
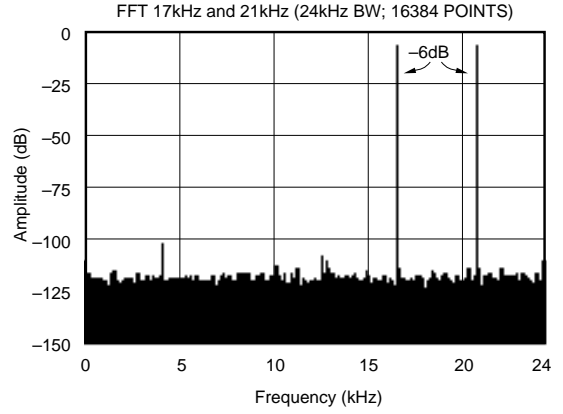
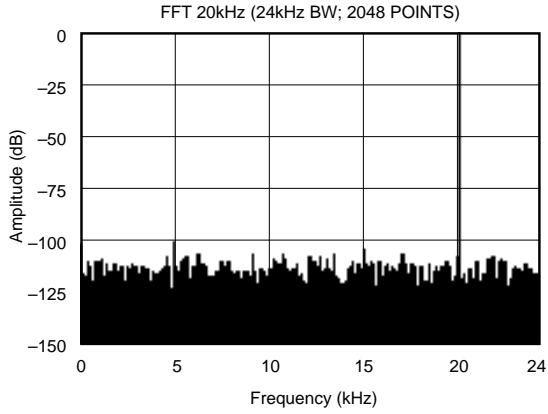

THEORY OF OPERATION

OVERVIEW

The PCM1750 is a dual 18-bit successive approximation CMOS analog-to-digital converter with serial data outputs designed especially for digital audio and similar applications. The single-chip converter is fabricated on a $3\mu\text{m}$ P-well CMOS process which includes poly-poly capacitors, laser-trimmable nichrome resistors, and two layers of interconnect metal. The dual converter employs a switched capacitor architecture which provides separate, simultaneous S/H (sample/hold) functions for each input channel. The separate S/H for each channel results in a desired feature called

co-phase sampling which means that both S/H circuits are switched at the same time into the HOLD mode to capture their respective input signals simultaneously. This eliminates phasing errors produced by alternative architecture ADCs which do not sample the two input channels at the same time.

Switched binary-weighted poly-poly capacitors are used in CDAC (capacitive digital-to-analog converter) configurations to form the successive approximation converter sec-

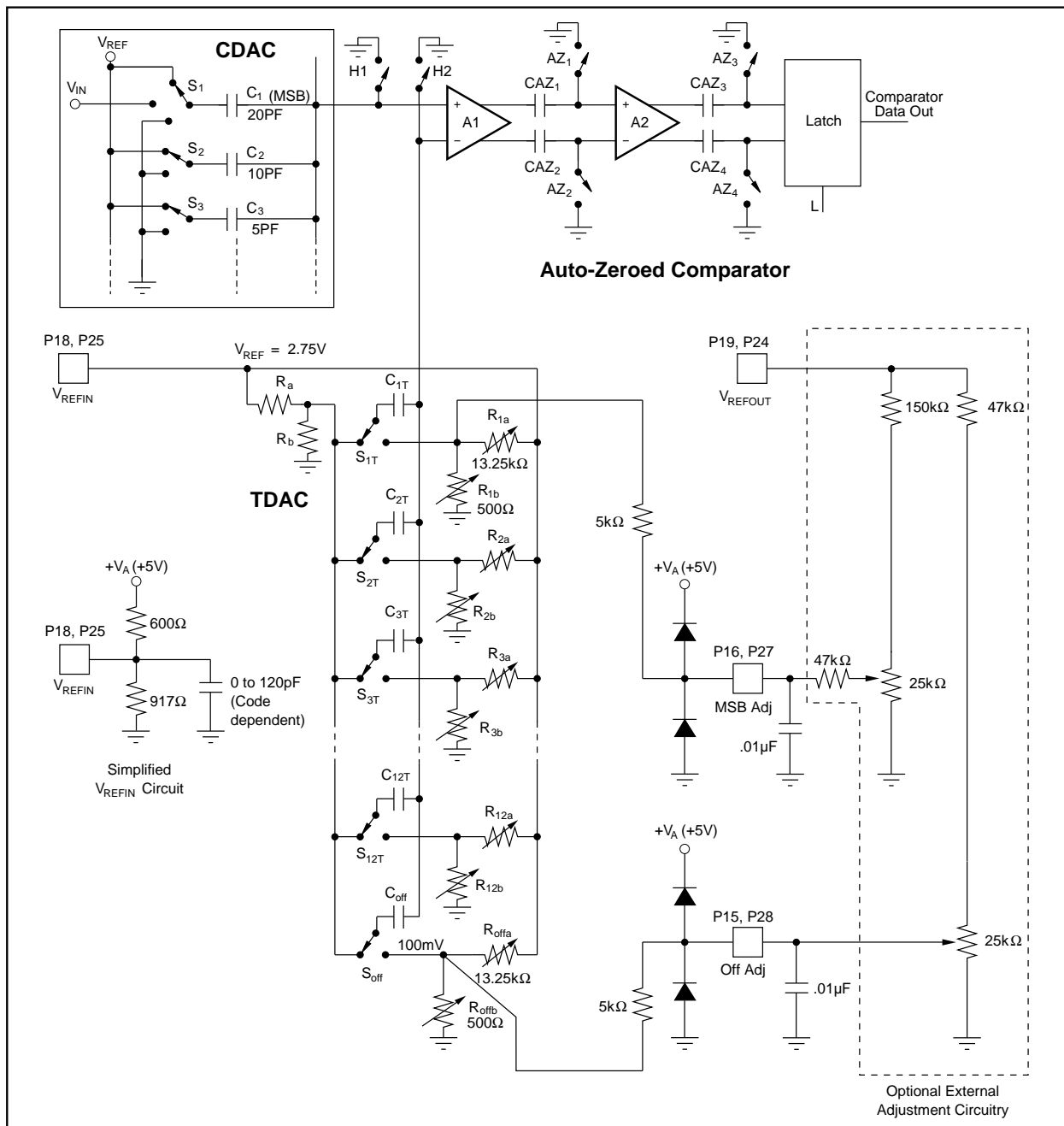

FIGURE 1. PCM1750 Simplified Circuit Diagram.

tions of the PCM1750. Two other switched-capacitor TDACs (trim-DACs, which employ laser-trimmed nichrome resistors) are also used to provide small correction voltages to the latching comparators. These small correction voltages compensate for ratio matching errors of the binary-weighted capacitors in the CDAC. The comparators contain autozeroed preamplifier stages ahead of the latching amplifier stage to produce a one bit, serial data stream that controls the successive approximation algorithm for each channel of the PCM1750.

To simplify user application, the PCM1750 includes an internal band-gap reference with fast settling buffer amplifiers to drive the CDACs. The dual converters operate synchronously (to minimize digital noise conversion errors) using an external system clock (normally at 1X, 2X or 4X the standard 48kHz audio sampling rate). By operating at a 2X or 4X oversampling rate the roll-off requirement for the input anti-aliasing filters is relaxed. For example, 1X systems typically use a 9 to 11 pole LPF (low pass filter) whereas a 4X system can use a 6th (or smaller) order filter when an appropriate digital filter such as the DF1750 is used in conjunction with the sampling system. Oversampling also has the added benefit of improved signal to noise ratio and total harmonic distortion. Two serial outputs, one for each

input channel, provide binary-two's-complement coded output to an optional external digital decimation filter when over sampling operation is desired. The use of the optional companion digital filter, the DF1750, is described later in the installation and application sections of this product data sheet. A separate product data sheet is also available for the Burr-Brown DF1750 giving all the specifications and performance diagrams associated with this digital filter.

SAMPLE (TRACKING) MODE

After each conversion, the dual ADC returns to the SAMPLE mode in order to track the input signals. The switches shown in the simplified circuit diagram of Figure 1 will then be in the following states: S1 connects V_{IN} to C1 ; S2 to S18 connect C2 to C18 to V_{REF} ; H1 and H2 connect the top plates of the capacitor arrays to analog common; and the latching comparator is switched into its auto-zero mode by closing AZ1 to AZ4. Notice that C1 serves two purposes: it samples and stores the input signal V_{IN} and it is the MSB of the CDAC. Storing V_{REF} on C2 to C18 creates a bipolar offset, enabling V_{IN} to cover a span from $-V_{REF}$ to $+V_{REF}$. The 1/f noise as well as the DC input offset voltage of the comparator are removed by an autozeroing cycle which

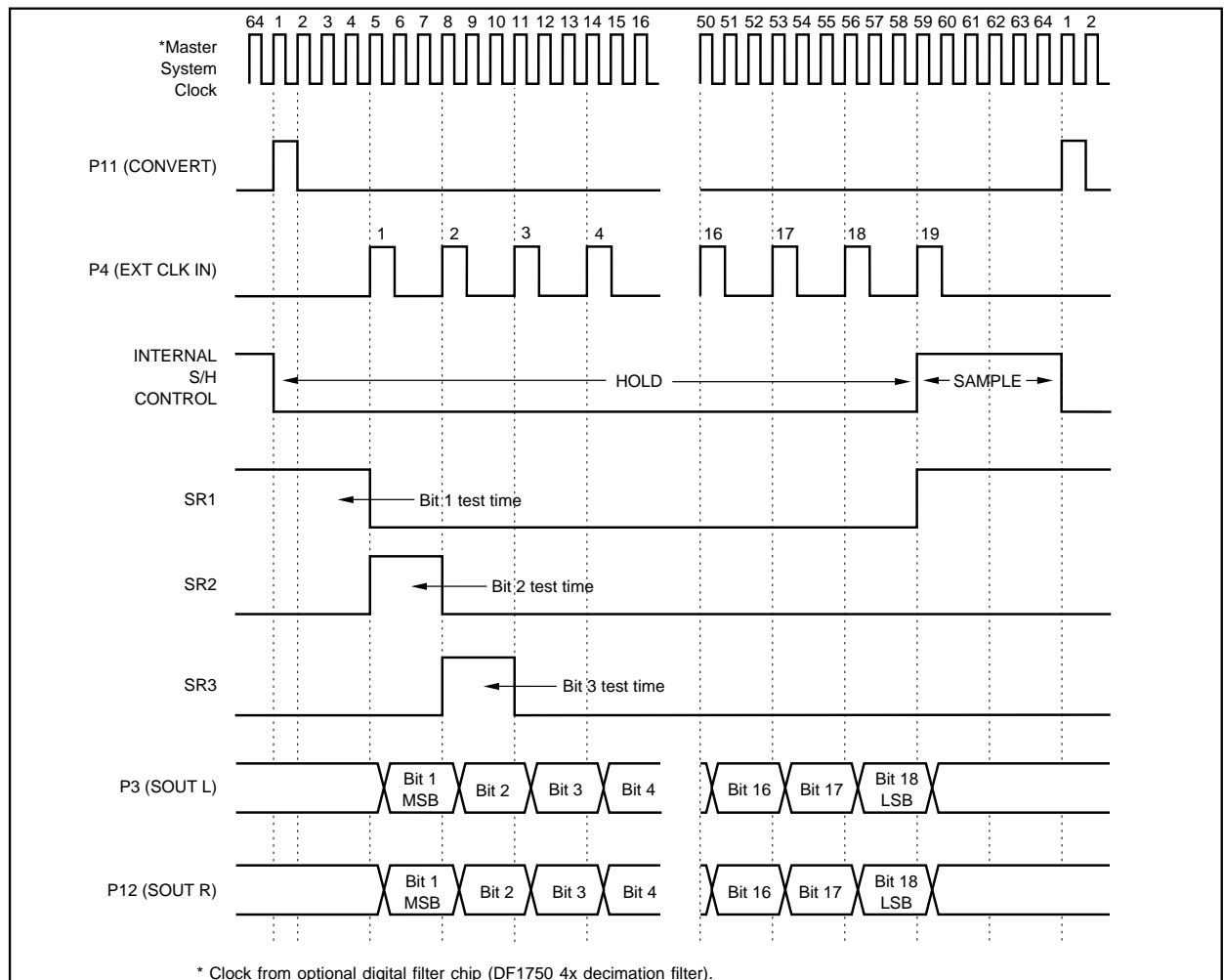

FIGURE 2. PCM1750 Input/Output Timing Diagram.

occurs during the SAMPLE period (see the timing diagram shown in Figure 2). These errors are stored on the AC coupling capacitors (CAZ1 to CAZ4, shown in Figure 1) between the gain stages. During the SAMPLE period the inputs to gain stages A1 and A2 and the latch are grounded by switches H1, H2, and AZ1 to AZ4. Capacitors CAZ1 and CAZ2 track the amplified offset voltage of gain stage A1 and capacitors CAZ3 and CAZ4 do the same for A2. At the beginning of a conversion cycle, the autozeroing switches open and the instantaneous amplified value of both the DC offset voltage and the low-frequency flicker noise is stored on the coupling capacitors to produce zero comparator offset during a conversion cycle.

SUCCESSIVE APPROXIMATION CONVERSION PROCESS

The timing diagram in Figure 2 illustrates the successive approximation routine of the PCM1750. Control signals CONVERT and CLK are derived from a master system clock which comes from a $256f_s$ (256 X the base sampling frequency of 48kHz) clock used by the optional digital filter. There are 64 clocks shown in the timing diagram because the PCM1750 is shown operating at 4 times the standard 48kHz sample rate (192kHz).

Several events occur on the rising edge of the CONVERT command. Switches AZ1 to AZ4, H1 and H2 open and switch S1 reconnects the MSB capacitor, C1, from V_{IN} to

analog common (see Figure 1). This terminates the comparator auto-zero cycle and simultaneously switches (co-phase sampling) both converters from tracking their respective input signals into the HOLD mode, thus capturing the instantaneous value of V_{IN} (with a small delay specified as the aperture time).

At the start of a conversion cycle when S1 is switched to analog common, the sampled input signal V_{IN} will appear at the comparator input as $-V_{IN}/2$ due to the 2-to-1 capacitive divider action of $C1 = C2 + C3 + \dots C18$. In a somewhat similar manner, V_{REF} is transferred to the comparator input as $-V_{REF}/2$ to create a bipolar offset.

The 19-bit shift register, shown in Figure 4, controls testing of the bits of the dual ADCs beginning with bit-1 (MSB) and proceeding one bit at a time to bit-18 (LSB), leaving ON those bits that don't cause the cumulative value of the CDAC to exceed the original input value and leaving OFF those bits that do. Since the bits of both channels are tested together, only one shift register is required to control both ranks of 18 data latches.

For example, the testing of bit-2 proceeds in the following manner. The positive pulse from the second shift register element SR2, (see Figure 2 and 4) is applied to the bit-2 data latch and NOR gate. The NOR gate in turn drives S2 and switches bit-2 at the beginning of the bit-2 test interval. Note that the bit interval must be long enough to allow both the comparator input to settle and the comparator to respond. On

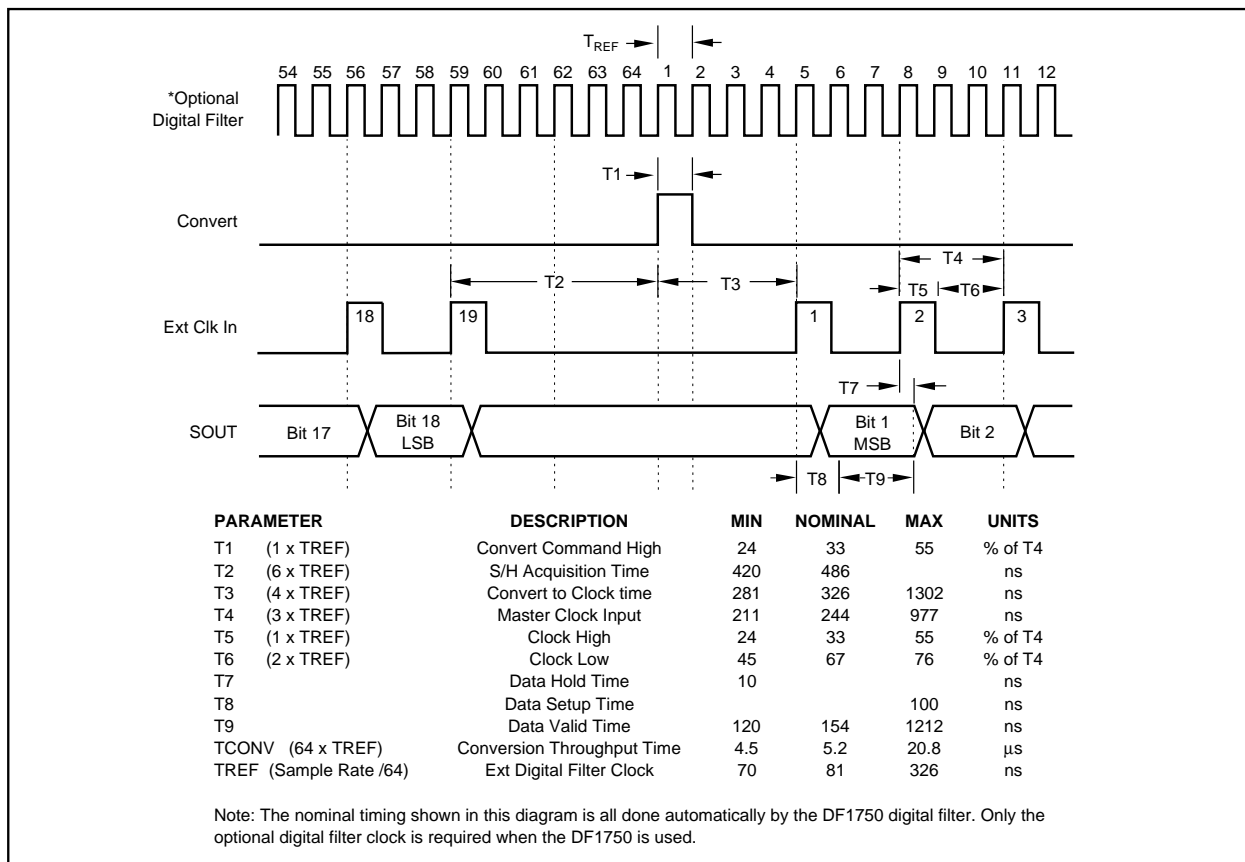

FIGURE 3. PCM1750 Setup and Hold Timing Diagram.

the next rising edge of CLKIN, at the end of the test interval, the comparator latch is strobed, providing a feedback logic level which tells the second data latch if bit-2 should be kept or rejected. This logic level is stored in the data latch and is passed on to switch S2 via the NOR gate on the falling edge of the pulse from SR2. This decision to keep or reject bit-2 moves the comparator input closer to a null condition, namely, zero potential. This sequential process continues for bit-3 through bit-18 and nulls the comparator inputs to within a value limited by the total system noise and the resolution/speed of the comparator.

Notice from the timing diagram in Figure 2 that the successive approximation algorithm operates synchronously with an external clock to minimize digitally-coupled switching noise from corrupting either the sample-to-hold operation or the critical comparator bit decisions. The two serial output data streams are derived synchronously from the respective latched comparator outputs and are available after a delay of one CLKIN cycle as illustrated in Figure 2. The serial output driver cells are TTL and CMOS compatible.

DIFFERENTIAL LINEARITY CALIBRATION

To understand the calibration of the PCM1750 it is necessary to discuss some of the characteristics of poly-poly capacitors. Poly capacitors are known to have equal or better stability and matching properties when compared to other precision components such as thin film resistors. On a well

controlled process, ratio matching is typically 0.1%—a very respectable number for an untrimmed component. Even more impressive is their ratio tracking versus temperature of approximately 0.1ppm/°C.

Achieving DLE (differential linearity error) of less than 1/2 LSB at the 16-bit level requires ratio matching of the more significant bits to about 0.001%. Since the untrimmed ratio matching of poly capacitors is about two orders of magnitude larger than this requirement, a one-time factory calibration of the upper bits is required as described in the next section. Next, consider the effect of temperature due to the ratio tracking of 0.1ppm/°C. Over a 50°C span, DLE will change less than 1LSB at 18-bits; therefore, recalibration at temperature extremes is not necessary. Because of this excellent stability versus temperature (and versus time, also), the one-time factory calibration to correct initial DLE is more than satisfactory in meeting the accuracy requirements of the PCM1750.

TDAC OPERATION

Operation of the TDAC (trim DAC), which is laser trimmed at the wafer level, is described using bit-1 as an example. Switch S1T (see Figure 1) operates between two voltage levels—a reference level set by voltage divider Ra, Rb and a laser trimmable level set by R1a, R1b. The differences of these two levels is coupled by capacitor C1T to the minus input of the comparator to generate a correction voltage for

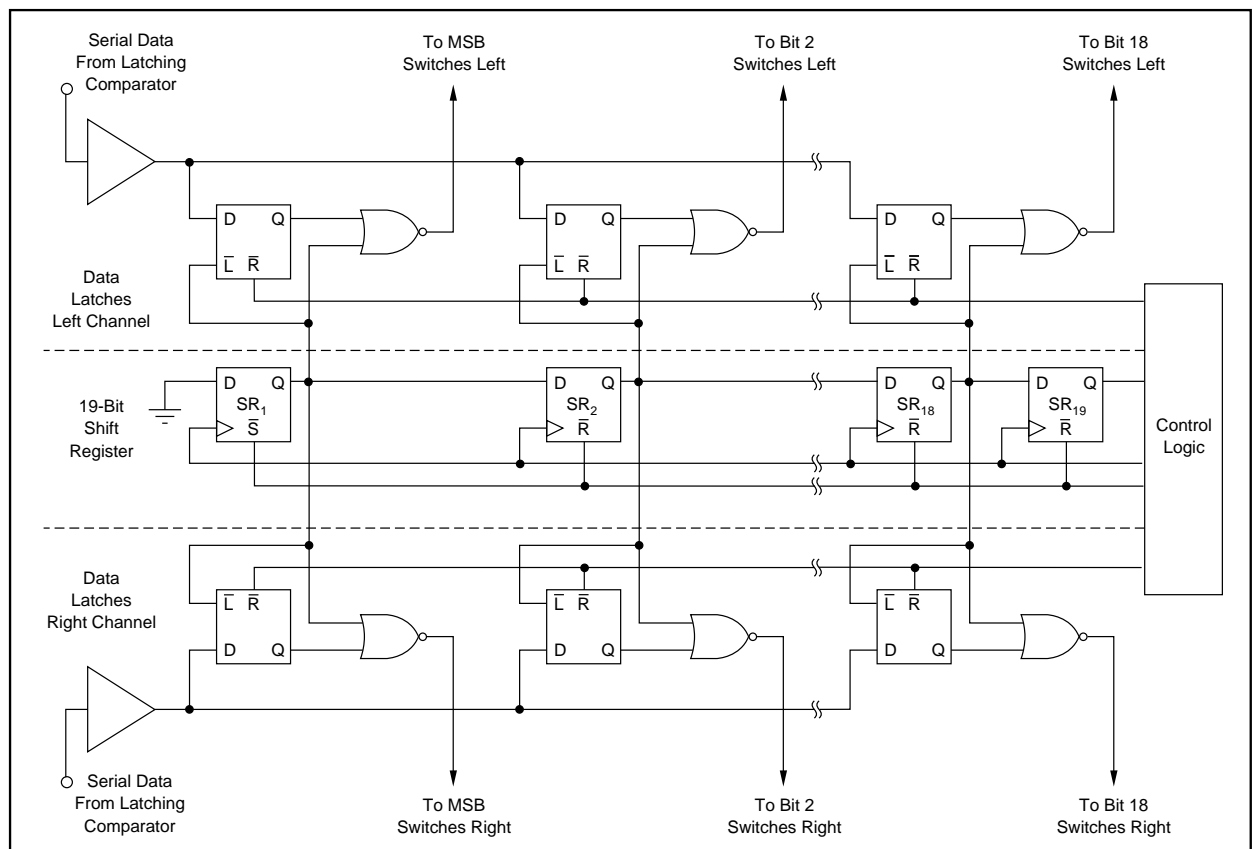

FIGURE 4. PCM1750 Successive Approximation Logic Diagram.

bit-1. The switches of the CDAC and the switches of the TDAC operate concurrently with each other, that is, when a decision is made to keep or reject bit-1, the same decision is made for the correction voltage for bit-1. Even though the ratio stability of the nichrome resistors used in the TDAC may not be as good as the poly capacitors, it is inconsequential because the correction voltage of each bit has a limited range of adjustment.

The DLE at the major carry (a code change from 111...111 to 000...000; in binary two's complement coding) is typically $\pm 1/2$ LSB at the 16-bit level, which is sufficient to provide 90dB SNR and -30dB low level distortion (-60dB input). For applications requiring less DLE at the major carry, a pin is provided for each channel to make an external MSB adjustment.

DISCUSSION OF SPECIFICATIONS

RESOLUTION AND DYNAMIC RANGE

The theoretical resolution of the PCM1750 is 18-bits. The maximum possible number of output codes or counts at 18-bits is 262,144 or 108dB (calculated by raising 2 to the 18th power). The relative accuracy of any A/D converter, however, is more a function of its absolute linearity and signal-to-noise ratio than how many bits of resolution it has. These more pertinent specifications are described later in this section.

Dynamic range, as it is usually defined for digital audio converters, is the measure of THD+N at an effective input signal level of -60dB referred to 0dB. For the PCM1750 this value is typically 90dB and a minimum of 88dB (for audio bandwidth = 20Hz to 24kHz, THD+N at -60db = -30 db typ, -28dB max; $f_{IN} = 1\text{kHz}$ and $f_s = 192\text{kHz}$). Resolution is also commonly used as a theoretical measure of dynamic range, but it does not take into account the effects of distortion and noise at low signal levels.

ANALOG INPUT RANGE

The analog input range for the PCM1750 is a bipolar $\pm 2.75\text{V}$ (nominal). Table I gives the precise input/output and voltage/code relationships for the PCM1750. Figure 5 shows these same relationships in a graphical format. It should be noted that the computed voltage input levels represent center values (the midpoint between code transitions). Output coding is in binary two's complement.

DIGITAL OUTPUT	ANALOG INPUT	VOLTAGE INPUT
262144 LSBs	Full Scale Range	5.50000000V
1 LSB	Minimum Step Size	20.98083496 μV
1FFFF _{HEX}	+Full Scale	+2.74997902V
00000 _{HEX}	Bipolar Zero	0.00000000V
3FFFF _{HEX}	Bipolar Zero -1LSB	-0.00002098V
20000 _{HEX}	-Full Scale	-2.75000000V

TABLE I. Analog Input to Digital Output Relationships.

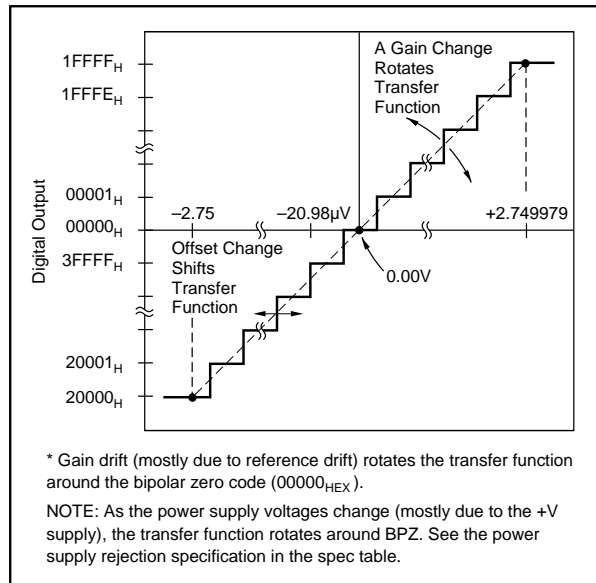

FIGURE 5. Analog Input to Digital Output Diagram.

From Figure 5, the effects of offset and gain errors can be visualized. These errors can change value in response to changes in temperature and/or supply voltage. In addition, gain error (or the full scale range, FSR) changes in direct proportion to the $V_{REF_{IN}}$ voltage value.

SAMPLE AND HOLD PARAMETERS

Aperture Delay and Uncertainty

Aperture delay is the time required to switch from the SAMPLE to HOLD mode. This time is typically 10ns for the PCM1750 and it is constant. Aperture uncertainty (jitter) is the amount of uncertainty associated with the aperture delay. Aperture uncertainty affects the overall accuracy of the converter and is greatest at the maximum input frequency of the converter. The formula for determining the maximum input frequency (f_{MAX}) for a given error contribution due to aperture uncertainty is: $f_{MAX} = (2 \times \pi \times t_{jitter} \times 2^N)^{-1}$ where t_{jitter} is the RMS aperture uncertainty and 2^N is the desired SNR (signal-to-noise ratio) expressed in total number of quantization levels. A 15-bit SNR, therefore, would be expressed as 2^{15} or 32768. Using the typical PCM1750 aperture jitter of 50ps_{rms} and an SNR at the 15-bit level, $f_{MAX} = (2 \times \pi \times 50\text{ps} \times 32768)^{-1}$ or 97.1kHz. This matches very closely with the rated dynamic accuracy of the PCM1750 where THD+N = -88dB max. This means the typical aperture jitter of PCM1750 only becomes a factor when input signals to it exceed 97kHz and/or an SNR greater than 15 bits is desired.

Input Bandwidth

The full power bandwidth of the PCM1750 is that input frequency above which significant distortion is observed (THD+N > 10-bits or -60dB for a full scale input signal). In the data sheet, this number is specified as typically being 500kHz. In wideband operation (when no digital filter is used) the additional full power bandwidth of the PCM1750

can be used to purposely alias a band-limited signal down into the baseband of the converter. This technique is called undersampling and can be used to directly down-convert an intermediate frequency riding on a much higher carrier frequency.

DIGITAL I/O AND TIMING

Input/Output Logic Compatibility

Digital logic on the PCM1750 is CMOS compatible. Digital outputs on the PCM1750 are capable of driving a minimum of two standard TTL input loads.

Digital output coding is in binary two's complement. Table I gives the precise input/output voltage/code relationships for the PCM1750. Figure 5 shows these same relationships in a graphical format.

Convert Command and External Clock Input

A conversion is initiated on its positive going edge of the convert command. Although the convert command can return low at any time (prior to 50ns before the rising edge of the 19th clock), a typical convert command pulse width of 81ns (as called out in Figure 3) is specified for a 192kHz sample rate (f_s). The reason for a pulse width spec is to reduce problems associated with digital logic feedthrough noise. The return of convert command to a logic low level in the specified time interferes least with the successive approximation process. Also, it should be noted that putting fast logic edges (<5ns) on convert command (P11) and the external clock input (P4) may cause logic feedthrough to the analog stages in the converter and will result in added distortion during the sampling and conversion process. Using the optional DF1750 digital filter provides adequately slow transitions to maintain full specification performance. If necessary, an external RC, on the convert command line may be used to slow fast logic edges.

As with the convert command, the external clock input is positive edge triggered and is not duty-cycle dependent other than to improve digital feedthrough noise immunity. A 50% duty cycle clock can be used instead of 33% if desired. Refer to Figure 3 for recommended timing relationships. Regardless of what clock duty cycle is used, all operations relating to valid data clocking should be synchronized to the rising edge of the clock input.

Although there is a maximum conversion time called out in the specification table, the PCM1750 can have a considerably longer conversion cycle. Droop of the internal capacitors will ultimately determine what the true maximum conversion time can be. The min/typ/max times shown in Figure 3 are based on minimum sample rate of 48kHz, a typical of 192kHz, and a maximum of 222kHz. All specifications are tested at 192kHz. The minimum sample rate assumption is based on clock periods that increase as time between convert commands increases. Any sample rate down to near DC can be utilized by observing maximum clock cycle requirements and spacing convert commands to achieve lower sample rates. This means that the time interval T2 shown in Figure 3 does not have a maximum value.

Clock Lockout

Any number of clocks can be given to the PCM1750 beyond the 19 required for normal operation. If a continuous clock is used, all clocks beyond the 19th are gated off by the PCM1750's internal logic until the next positive going edge of the convert command. The converter also goes into the sample (track) mode starting on the positive edge of the 19th clock until the next positive edge of the convert command, regardless of how many additional clocks are offered. The ideal operation of the converter stops the clock input after the 19th during this critical signal acquisition time. This is the timing shown in Figure 3. The critical timing aspect that must be observed if a clock input other than the recommended is used, is that ample time following the positive edge of convert command proceed the next rising clock edge. If this time is shortened, the most important bit-1 (MSB) decision, which is finalized on the first clock edge after convert command, will be adversely affected. In other words, the clock input cannot have a rising edge during the time interval T3 shown in Figure 3.

SIGNAL-TO-NOISE RATIO

Another specification for A/D converters is signal-to-noise ratio (SNR). For this measurement, a full-scale 1kHz signal is applied and the sampling rate of the PCM1750 is set at 192kHz. An FFT is performed on the digital output and the noise power in the non-harmonic audio-bandwidth frequency bins (20Hz to 24kHz) is summed and expressed in relation to the full-scale input signal.

One advantage of using the PCM1750 in this oversampled mode with the optional DF1750 digital decimation filter is that the converter noise is spread over the full 0Hz to 96kHz passband and then suppressed by the digital filter stopband attenuation (from 24kHz to 96kHz). This effectively increases the SNR of the PCM1750 by 6dB when it is used as an audio bandwidth converter. The other advantage is that the need for a higher-order anti-aliasing input filtering is greatly reduced.

THD + N

The key specification for the PCM1750 is total harmonic distortion plus noise (THD+N). In terms of signal measurement, THD+N is the ratio of $\text{Distortion}_{\text{RMS}} + \text{Noise}_{\text{RMS}} / \text{Signal}_{\text{RMS}}$ expressed in dB. For the PCM1750, THD+N is 100% tested at all three specified input levels using the production test setup shown in Figure 6. For this measurement, as with the SNR test, a full-scale 1kHz signal is applied and the sampling rate of the PCM1750 is set at 192kHz (which is 4X the standard digital audio sample rate of 48kHz). An FFT is performed on the digital output and the total power in all audio-bandwidth frequency bins (20Hz to 24kHz) is summed and expressed in relation to the full-scale input signal.

For the audio band, the THD+N of the PCM1750 is essentially flat for all frequencies and input signal levels. In the *Typical Performance Curves* THD+N versus Frequency

plots are shown at four different input signal levels (with and without a 4X decimation filter): 0dB, -20dB, -40dB, and -60dB.

CHANNEL SEPARATION

To test channel separation a 1kHz signal sampled at 192kHz is placed on one input of the PCM1750 while the other input is held at 0V. An FFT is performed on the idle (0V) channel and the result checked to insure that the 1kHz tone is suppressed by a minimum of 96dB.

GAIN AND OFFSET ERRORS

Initial gain and bipolar offset errors are laser trimmed at the wafer level and 100% final tested to insure compliance with the electrical specifications. Bipolar offset errors can be further reduced to zero by using the optional offset adjustment circuitry shown in the connection diagram (Figure 7). Gain errors can be adjusted by varying V_{REF} to either channel of the converter. This is accomplished by either using an adjustable external reference or by placing buffer amplifiers with adjustable gain between $V_{REF_{OUT}}$ and $V_{REF_{IN}}$ as shown in Figure 8a.

INTEGRAL AND DIFFERENTIAL LINEARITY

DC Linearity Testing

The absolute linearity of the PCM1750 is on the order of 15 bits or more as can be seen from the THD versus Frequency plots in the *Typical Performance Curves*. Not every code in the converter must be 15-bit linear to achieve the specified THD+N performance, but a very high percentage will be that linear. The same observation also applies to differential linearity errors in the PCM1750. Because the PCM1750 is not 100% tested for DC linearity specifications, no minimum or maximum specifications are given for integral or differential linearity errors.

No Missing Codes Operation

A no missing codes specification is not given for the PCM1750 for the same reasons as given above. The PCM1750, however, typically has fewer than 16 codes (less than 0.01%) missing at a 14-bit resolution level. A 100% no missing codes specification cannot be maintained above the 12-bit level, although this has very little impact on overall dynamic performance (THD+N). The few missing codes that do occur at higher resolution levels are at the bit-2 and lower major carry transitions of the converter. There are typically no missing codes (at 14 bits) around the critical bipolar zero operation zone ($\pm 1/8$ of full scale range around bipolar zero or 0V). The critical bipolar differential linearity error can be reduced from its initial value to zero using the optional MSB adjustment circuitry shown in the connection diagram (Figure 7).

REFERENCE

The gain drift of the PCM1750 is primarily due to the drift associated with the reference. Better drift performance can be achieved using an external reference like the ones explained in the applications section (Figures 8b, 8c). The *Typical Performance Curves* plot of V_{REF} Output versus Temperature shows the full range of operation including initial error and typical gain drift. Pertinent performance data are found in the electrical specification table.

Reference Bypass

Both P18 and P25 ($V_{REF_{IN}}$) should be bypassed with a 10 μ F to 47 μ F tantalum capacitor. If there are important system reasons for using the PCM1750 reference externally, the outputs of P19 and P24 must be appropriately buffered, and bypassed (see Figure 8).

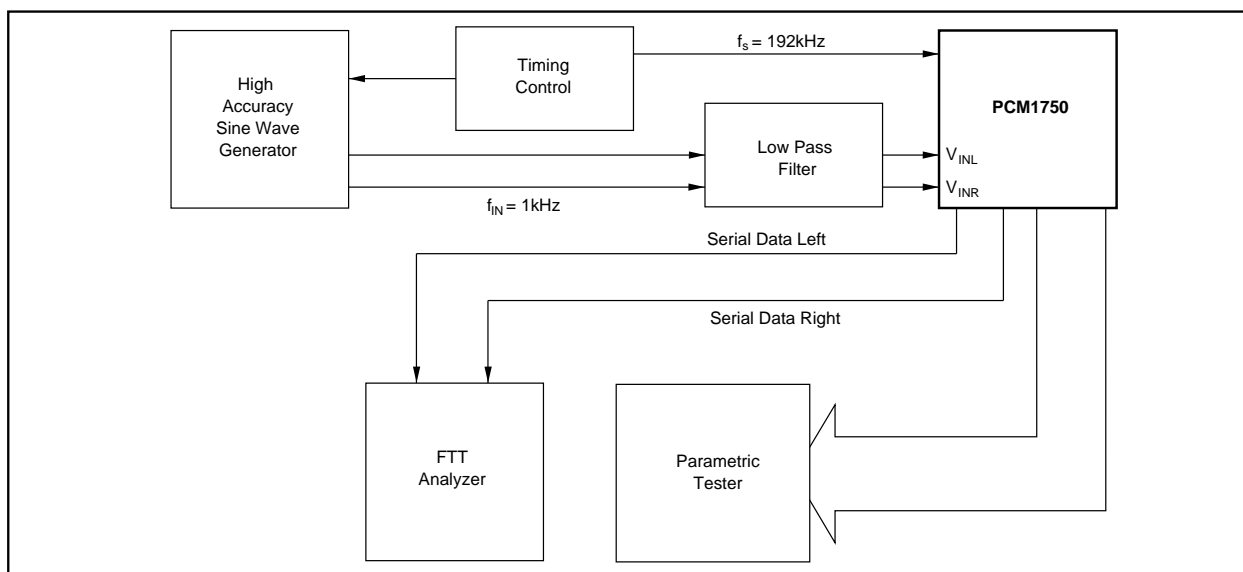

FIGURE 6. PCM1750 Production Test Setup.

POWER SUPPLY REJECTION

Because of the architecture of the PCM1750, power supply rejection varies with input signal size. The spec table value is expressed in the relative terms of percent of V_{IN} per percent change of the supply voltage. The PSR versus Frequency plot in the *Typical Performance Curves* show PSR expressed versus an increase in power supply ripple frequency.

PERFORMANCE OVER TEMPERATURE

Specification Temperatures

All critical specifications are tested at 25°C. The drift specification temperature range is from 0°C to +70°C. The PCM1750 will operate over the wider temperature range of -40°C to +85°C.

Gain and Offset Drift

Although the PCM1750 is primarily meant for use in dynamic applications, specifications are also given for more traditional DC drift parameters such as temperature gain and offset drift. The primary cause of drift in the PCM1750 is the bandgap reference. Much lower gain drift can be realized if necessary by using any circuit similar to the external reference circuits shown in Figure 8. Also, refer to the *Typical Performance Curves* of V_{REF} Output versus Temperature.

Dynamic Performance

Dynamic performance is predominated by the absolute linearity of the PCM1750. Because of the excellent ratio tracking versus temperature of poly-poly capacitors, there is virtually no change in dynamic performance of the converter over temperature (primarily THD+N). The dynamic specifications over temperature cannot be guaranteed, however, as they are not 100% tested.

INSTALLATION

ANTI-ALIASING FILTER

To prevent unwanted input signals from being aliased into the passband of the converter, it is necessary to suppress all out of band signals above 1/2 the sampling frequency of the ADC by using a low-pass filter. The requirement for an anti-aliasing filter, however, can be reduced by using oversampling techniques. By raising the sample rate of the converter by a factor of 2 or even 4, the roll off of the anti-aliasing filter can be reduced. In Figure 9, a 6th order, linear-phase, anti-aliasing filter is implemented using low-cost dual audio op amps. This filter will suppress frequencies above 96kHz by 80dB. For many applications a 4th or 2nd order anti-aliasing filter will be adequate when using the PCM1750 in the 4x oversampling mode.

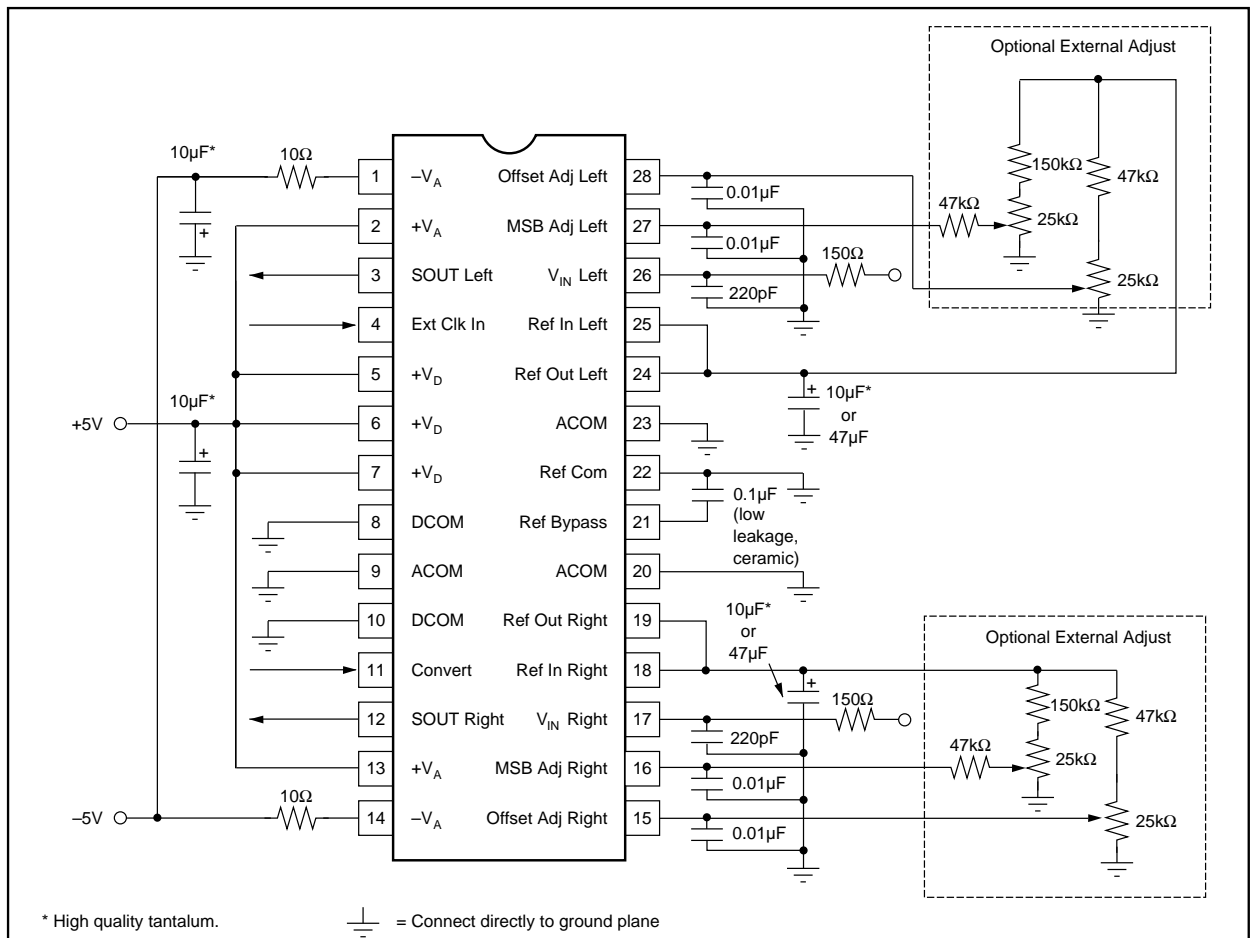

FIGURE 7. PCM1750 Connection Diagram.

INPUT SIGNAL CONDITIONING

RC Input Circuit

Note the 150Ω resistors and 220pF capacitors on each analog input as shown in the connection diagram (Figure 7). This input circuit configuration is required to achieve optimum SNR performance of the PCM1750. Various other component values will yield satisfactory results, but the resistor should never exceed 200Ω.

Buffer Amplifier

To avoid introducing distortion, the PCM1750 input must be driven by a low active impedance source (op amps such as the NE5532, Burr-Brown OPA2604, or equivalent are ideal).

EXTERNAL ADJUSTMENTS

The simplified circuit diagram (see Figure 1) shows one of two complete channels on the PCM1750. The input switched capacitors, trim DAC and comparator are detailed. The trim DAC switches are activated whenever the corresponding bit is chosen during the successive approximation routine. The first 12 bits of the ADC have corresponding trim DAC circuits. The R1a to R12a and R1b to R12b resistors can be laser trimmed at the wafer level if necessary to correct for any nonlinearities. The nominal voltage for the internally generated V_{REF} is 2.75V and it is a relatively low impedance, buffered voltage output. It should be noted that just the act of connecting the optional adjustment circuits will affect the MSB DLEs and bipolar offsets since it is unlikely that the initial potentiometer settings (even if centered) would match the factory trimmed null potentials. If connected, the potentiometers must be properly adjusted.

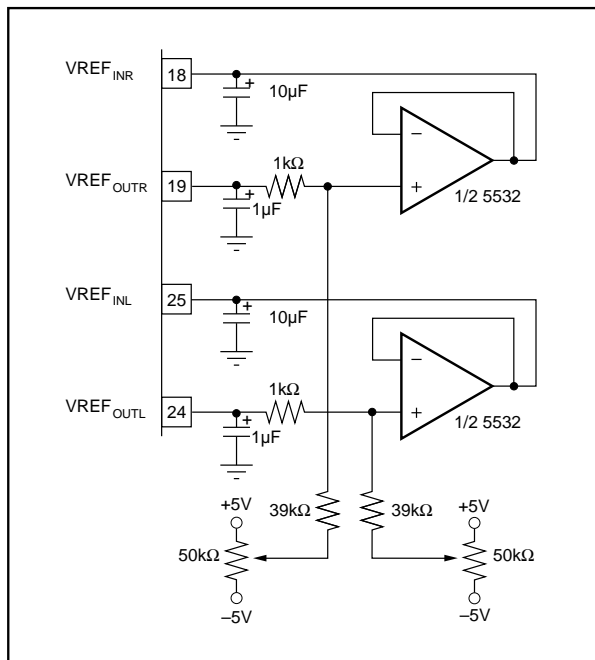

FIGURE 8a. Circuit for External Gain Adjustment Using the Internal Reference.

MSB Adjust

The MSB adjust pin connects to the center of the R1a/R1b resistive divider for bit-1. After laser trimming this point is nominally 100mV. All the MSB and offset adjust pins should be connected to ground using a 0.01μF capacitor, especially if traces to the potentiometers are long. If the adjust pins are not used, they should still be bypassed to ground.

Since there are internal 5kΩ resistors and clamp diodes to both ground and +5V on the MSB and offset adjust pins, there are obvious limits to their range of adjustment. With a nominal internal voltage on these points of +100mV, there will be a greater limitation in making negative adjustments than positive. A negative voltage at either adjustment pin, however, is acceptable up to one diode drop (-0.6V) below ground.

The preferred method of MSB DLE adjustment is to input a small level signal and adjust for minimum THD+N.

Offset Adjust

The offset adjust switch (S_{OFF}) position is controlled by whether the ADC is in the sample or hold mode. Switching from sample to hold effectively allows any charge offsets associated with the sampling process to be eliminated. Grounding the input to the converter as far ahead of the A/D as possible (in front of the anti-aliasing filter for example) and then adjusting the bipolar zero error will remove the offsets associated with the entire sampling system.

LAYOUT CONSIDERATIONS

Power Requirements

Noise on the power supply lines can degrade converter performance, especially noise and spikes from a switching power supply. Appropriate supplies or filters must be used. Although the PCM1750 positive supplies have separate digital and analog +5V, for most applications the +5V digital supply pins should be connected to the +5V analog supply. If they aren't connected together, a potential latchup condition can occur when the power supplies are not turned on at the same time. If one supply pin is powered and the other is not, the PCM1750 may latch up and draw excessive current. In normal operation, this is not a problem because both $+V_A$ and $+V_D$ should be connected together. However, during evaluation, incoming inspection, repair, etc., where the potential of a "hot" socket exists, care should be taken to power the PCM1750 only after it has been socketed.

All supplies should be bypassed as shown in Figure 7. The bypass capacitors should be placed as close to their respective supply pins as possible. Additional .01μF capacitors may be placed in parallel with the larger value capacitors to increase high-frequency rejection, but generally they are not required when high quality tantalums are used. The 0.1μF capacitor between P21 and P22 should be a low leakage type (such as ceramic) and must be put as close to these pins as possible to reduce noise pickup.

The PCM1750 is sensitive to supply voltages outside the absolute maximum ratings shown in the specification tables. Do not exceed -8V on the negative supplies at any time or irreversible damage may occur. Note the 10Ω resistors in series with each -5V supply line (shown in Figure-7) to help protect the part from severe damage if the supplies are over-ranged momentarily.

Grounding Requirements

Because of the high resolution and linearity of the PCM1750, system design problems such as ground path resistance and contact resistance become very important.

The ACOM and DCOM pins are separated internally on the PCM1750. To eliminate unwanted ground loops, all commons (both analog and digital) should be connected to the same low-impedance ground plane. This should be an analog ground plane separate from other high-frequency digital ground planes on the same board. If the analog and digital commons of the PCM1750 are connected to different ground planes, care should be taken to keep them within 0.6V of each other to insure proper operation of the converter.

A ground plane is usually the best solution for preserving dynamic performance and reducing noise coupling into sensitive converter circuits. Where any compromises must be made, the common return of the analog input signals should be referenced to the ACOM pins. This will prevent voltage drops in the power supply returns from appearing in series with the input signal.

Coupling between analog input and digital lines should be minimized by careful layout. For instance, if the lines must cross, they should do so at right angles. Parallel analog and digital lines should be separated from each other by a pattern connected to common.

If external MSB and offset adjust potentiometers are used, the potentiometers and related resistors should be located as close to the PCM1750 as possible.

Minimizing “Glitches”

Coupling of external transients into an analog-to-digital converter can cause errors which are difficult to debug. Care should be taken to avoid glitches during critical times in the sampling and conversion process. Since the PCM1750 has an internal sample/hold function, the signal that switches it into the HOLD state (CONVERT going HIGH) is critical, as it would be on any sample/hold amplifier. The CONVERT rising edge should have minimal ringing, especially during the 20ns after it rises.

APPLICATIONS

USING A DIGITAL FILTER

A 4x decimation filter is available for the PCM1750 called the DF1750. It is available in a 28-pin DIP or a 40-pin SOIC package. The use of this filter greatly eases the implementation of the PCM1750 in audio band applications.

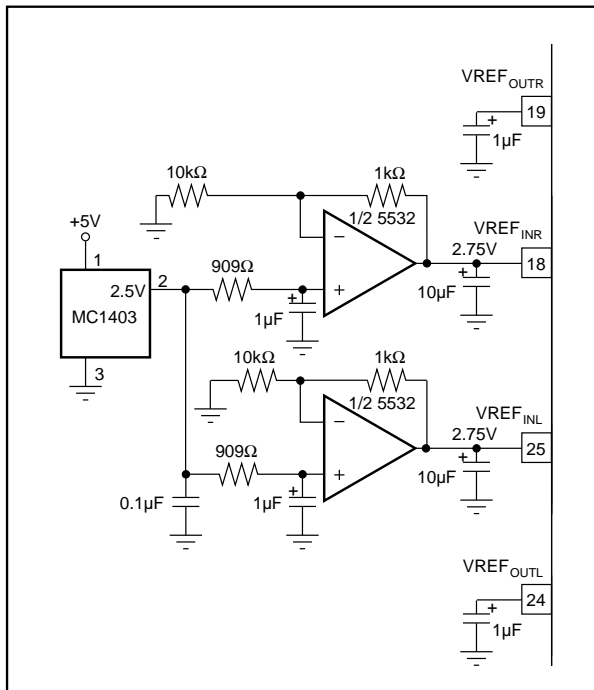

FIGURE 8b. External Reference Circuit Using Standard 2.5V Reference.

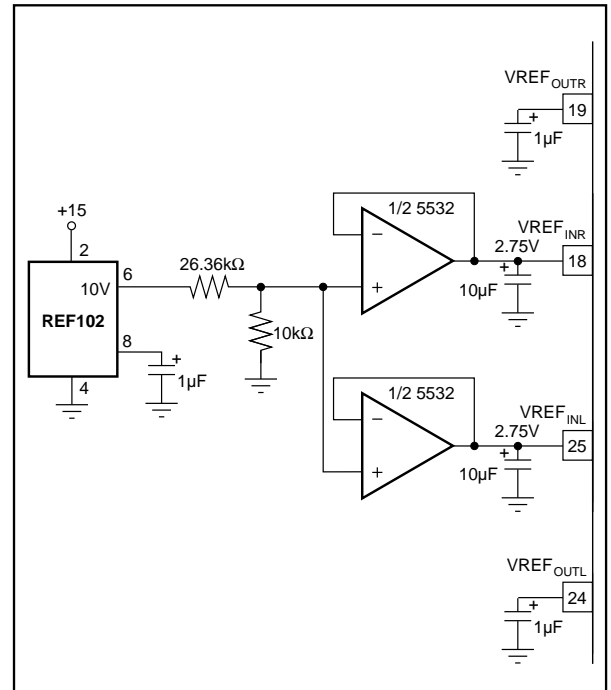

FIGURE 8c. Low Noise, Low Drift External Reference Circuit.

USING AN EXTERNAL REFERENCE

Normally $VREF_{OUT}$ is connected directly to $VREF_{IN}$. The typical value for $VREF$ versus Temperature is shown in the *Typical Performance Curves*. If better drift or power supply rejection performance is desired, one of the external reference circuits shown in Figures 8b and 8c can be used. Note that the decoupling capacitors are still connected to $VREF_{IN}$. External gain adjustment is now possible by using the variable output options available on some precision voltage references or by varying the gain on external buffer amplifiers. The range of acceptable external references is from $+2.0V$ to $+V_A - 2.0V$, with $2.5V$ types being the most commonly available. Full scale input voltage range will be $\pm VREF_{IN}$ (a $+2.5V$ $VREF_{IN}$ results in a $\pm 2.5V$ input range). If an external reference is used, P19 and P24 must be bypassed with at least $1\mu F$ capacitors.

SAMPLING A/D SYSTEM

Figure 9 is a partial schematic of the demonstration fixture for the PCM1750 (orderable by model number DEM1133). It shows the implementation of (1) a 6th order, linear-phase, anti-aliasing filter (22kHz low-pass); (2) the PCM1750P A/D converter; and (3) a 4x digital decimation filter called

the DF1750P. Not shown on this schematic, but included on the demo fixture, are latched parallel data outputs with strobe and a serial digital interface format (SPDIF) data transmitter. Also included on the DEM1133 are user bread-board areas for application specific circuit implementation.

CONNECTION TO DSP WITH DIGITAL FILTER

The PCM1750 and DF1750 combination can be connected to the serial ports of most popular DSP processor ICs (such as those made by AT&T, Motorola, TI, and AD) by adding a small amount of external glue logic. Figures 10 and 11 show the timing diagram and schematic for this interface.

To use this interface, the DSP processor IC must be configured for 32-bit word inputs. The glue logic generates a flag bit, as the first bit of the 32-bit word, that signifies either left or right channel data. The flag bit will be low for left channel data and high for right channel data.

The DF1750 can be configured for either 16- or 20-bit data, although only 16-bit data is shown in Figure 10. After the data is transferred into the DSP processor IC, it must be shifted toward the LSB by one bit in order to compensate for a clock delay in the glue logic.

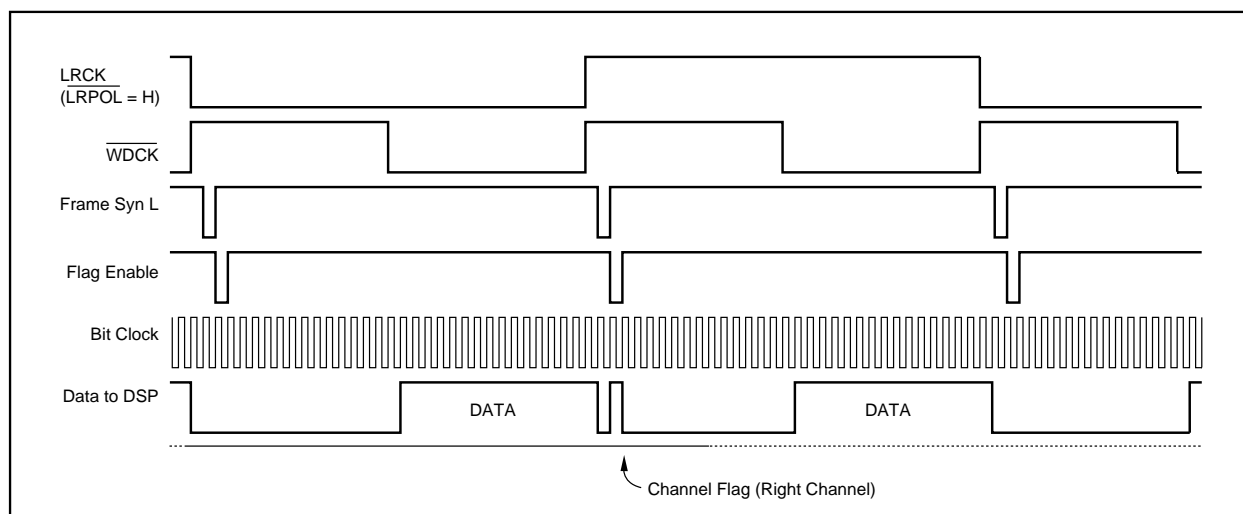

FIGURE 10. PCM1750/DF1750 To DSP IC Timing Diagram.

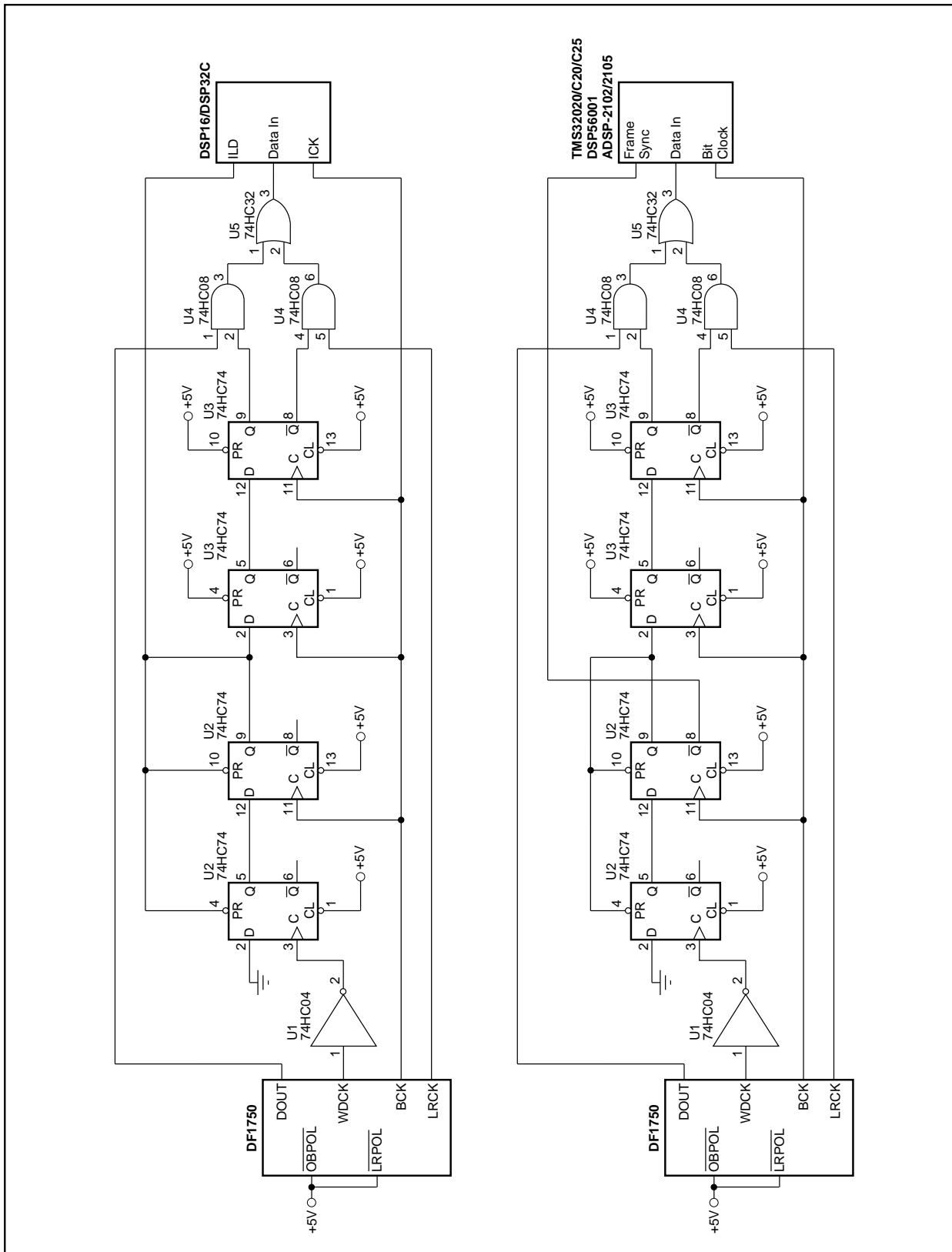

FIGURE 11. PCM1750/DF1750 to DSP IC Schematic.