

**PGA206**  
**PGA207**

## High-Speed Programmable Gain INSTRUMENTATION AMPLIFIER

### FEATURES

- **DIGITALLY PROGRAMMABLE GAINS:**  
PGA206:  $G=1, 2, 4, 8V/V$   
PGA207:  $G=1, 2, 5, 10V/V$
- **TRUE INSTRUMENTATION AMP INPUT**
- **FAST SETTLING: 3.5 $\mu$ s to 0.01%**
- **FET INPUT:  $I_B = 100pA$  max**
- **INPUT PROTECTION:  $\pm 40V$**
- **LOW OFFSET VOLTAGE: 1.5mV max**
- **16-PIN DIP, SOL-16 SOIC PACKAGES**

### APPLICATIONS

- **MULTIPLE-CHANNEL DATA ACQUISITION**
- **MEDICAL, PHYSIOLOGICAL AMPLIFIER**
- **PC-CONTROLLED ANALOG INPUT BOARDS**

### DESCRIPTION

The PGA206 and PGA207 are digitally programmable gain instrumentation amplifiers that are ideally suited for data acquisition systems.

The PGA206 and PGA207's fast settling time allows multiplexed input channels for excellent system efficiency. FET inputs eliminate  $I_B$  errors due to analog multiplexer series resistance.

Gains are selected by two CMOS/TTL-compatible address lines. Analog inputs are internally protected for overloads up to  $\pm 40V$ , even with the power supplies off. The PGA206 and PGA207 are laser-trimmed for low offset voltage and low drift.

The PGA206 and PGA207 are available in 16-pin plastic DIP and SOL-16 surface-mount packages. Both are specified for  $-40^{\circ}C$  to  $+85^{\circ}C$  operation.

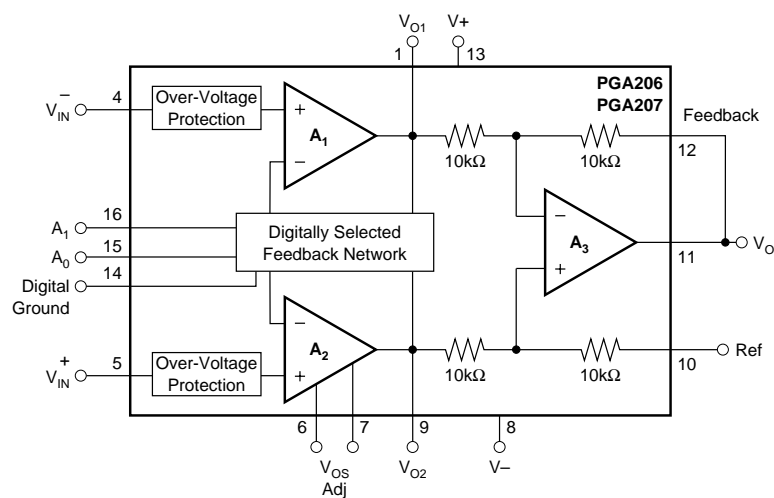

# SPECIFICATIONS

At  $T_A = +25^\circ\text{C}$ ,  $V_S = \pm 15\text{V}$ ,  $R_L = 2\text{k}\Omega$  unless otherwise noted.

PARAMETER	CONDITIONS	PGA206P, U PGA207P, U			PGA206PA, UA PGA207PA, UA			UNITS
		MIN	TYP	MAX	MIN	TYP	MAX	
<b>INPUT</b> Offset Voltage, RTI Initial vs Temperature vs Power Supply Long-Term Stability Impedance, Differential Common-Mode Common-Mode Voltage Range <sup>(1)</sup> Safe Input Voltage Common-Mode Rejection	All Gains $T_A = +25^\circ\text{C}$ $T_A = T_{\text{MIN}}$ to $T_{\text{MAX}}$ , $G = 8, 10$ $V_S = \pm 4.5\text{V}$ to $\pm 18\text{V}$  $V_O = 0\text{V}$  $V_{\text{CM}} = \pm 11\text{V}$ , $\Delta R_S = 1\text{k}\Omega$ $G = 1$ $G = 2$ $G = 4$ or $5$ $G = 8$ or $10$		$\pm 0.5$ $\pm 2$ $\pm 5$ 4.5 $10^{13} \parallel 1$ $10^{12} \parallel 4$ $\pm( V_S  - 4)$	$\pm 1.5$  $\pm 20$   $\pm 40$		$\pm 1$ * $\pm 10$ * * * *	$\pm 2.5$  $\pm 40$    *	mV $\mu\text{V}/^\circ\text{C}$ $\mu\text{V}/\text{V}$ $\mu\text{V}/\text{mo}$ $\Omega \parallel \text{pF}$ $\Omega \parallel \text{pF}$ V V
<b>INPUT BIAS CURRENT</b> vs Temperature Offset Current vs Temperature	$V_{\text{IN}} = 0$		2 See Typical Curve 1 See Typical Curve	100  100		* * * *	*  *	pA  pA
<b>NOISE VOLTAGE, RTI</b> f = 10Hz f = 100Hz f = 1kHz $f_B = 0.1\text{Hz}$ to 10Hz Noise Current f = 1kHz	$G = 8, 10$ ; $R_S = 0\Omega$		30 20 18 1			* * * *		$\text{nV}/\sqrt{\text{Hz}}$ $\text{nV}/\sqrt{\text{Hz}}$ $\text{nV}/\sqrt{\text{Hz}}$ $\mu\text{Vp-p}$ $\text{fA}/\sqrt{\text{Hz}}$
<b>GAIN</b> Gain Error Gain vs Temperature <sup>(2)</sup> Nonlinearity	All Gains, $V_O = \pm 11\text{V}$		$\pm 0.01$ $\pm 1$ $\pm 0.0003$	$\pm 0.05$ $\pm 10$ $\pm 0.002$		* * *	$\pm 0.1$ * $\pm 0.005$	% $\text{ppm}/^\circ\text{C}$ % of FSR
<b>OUTPUT</b> Voltage, Positive Negative Load Capacitance Stability Short-Circuit Current		(V+) -4 (V-) +4	(V+) -2.3 (V-) +1.5		* *	* *		V V pF mA
<b>FREQUENCY RESPONSE</b> Bandwidth, -3dB  Slew Rate Settling Time, 0.1% 0.01% Output Overload Recovery	$G = 1$ $G = 2$ $G = 4, 5$ $G = 8, 10$  $V_O = \pm 10\text{V}$ , $G = 1$ to 10 20V Step, All Gains 20V Step, All Gains 50% Overdrive		5 4 1.3 600 25 2 3.5 1.5			* * * * * * * *		MHz MHz MHz kHz V/ $\mu\text{s}$ $\mu\text{s}$ $\mu\text{s}$ $\mu\text{s}$
<b>DIGITAL LOGIC INPUTS</b> Digital Ground Voltage, $V_{\text{DG}}$ Digital Low Voltage Digital Input Current Digital High Voltage Gain Switching Time		V- V-  $V_{\text{DG}} + 2$	1	(V+) -4 $V_{\text{DG}} + 0.8\text{V}$  V+	* *  *	* *  *		V V pA V ns
<b>POWER SUPPLY</b> Voltage Range Current	$V_{\text{IN}} = 0\text{V}$	$\pm 4.5$	$\pm 15$ $+12.4/-11.2$	$\pm 18$ $\pm 13.5$	*  *	*  *	*  *	V mA
<b>TEMPERATURE RANGE</b> Specification Operating Thermal Resistance, $\theta_{\text{JA}}$		-40 -40	80	+85 +125	* *	* *		$^\circ\text{C}$ $^\circ\text{C}$ $^\circ\text{C}/\text{W}$

\* Specification same as PGA206P or PGA207P.

NOTES: (1) Input common-mode range varies with output voltage—see typical curves. (2) Guaranteed by wafer test.

The information provided herein is believed to be reliable; however, BURR-BROWN assumes no responsibility for inaccuracies or omissions. BURR-BROWN assumes no responsibility for the use of this information, and all use of such information shall be entirely at the user's own risk. Prices and specifications are subject to change without notice. No patent rights or licenses to any of the circuits described herein are implied or granted to any third party. BURR-BROWN does not authorize or warrant any BURR-BROWN product for use in life support devices and/or systems.

## PIN CONFIGURATION

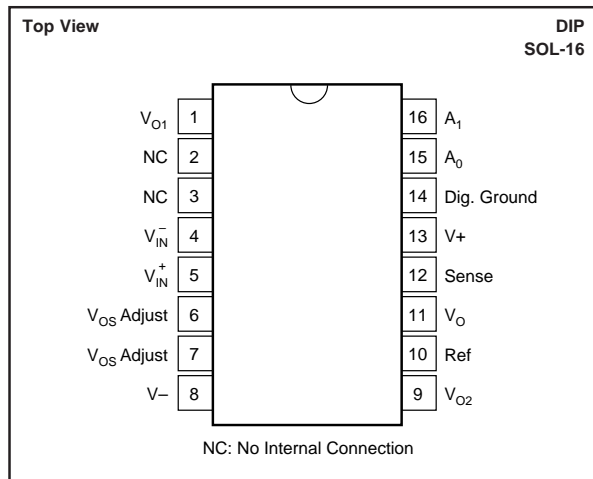

## PACKAGE INFORMATION

PRODUCT	PACKAGE	PACKAGE DRAWING NUMBER <sup>(1)</sup>
PGA206PA	16-Pin Plastic DIP	180
PGA206P	16-Pin Plastic DIP	180
PGA206UA	SOL-16 Surface Mount	211
PGA206U	SOL-16 Surface Mount	211
PGA207PA	16-Pin Plastic DIP	180
PGA207P	16-Pin Plastic DIP	180
PGA207UA	SOL-16 Surface Mount	211
PGA207U	SOL-16 Surface Mount	211

NOTE: (1) For detailed drawing and dimension table, please see end of data sheet, or Appendix C of Burr-Brown IC Data Book.

## ABSOLUTE MAXIMUM RATINGS

Supply Voltage .....	±18V
Analog Input Voltage Range .....	±40V
Logic Input Voltage Range .....	±V <sub>S</sub>
Output Short-Circuit (to ground) .....	Continuous
Operating Temperature .....	-40°C to +125°C
Storage Temperature .....	-40°C to +125°C
Junction Temperature .....	+150°C
Lead Temperature (soldering -10s) .....	+300°C

## ORDERING INFORMATION

PRODUCT	GAINS	PACKAGE	TEMPERATURE RANGE
PGA206PA	1, 2, 4, 8V/V	16-Pin Plastic DIP	-40°C to +85°C
PGA206P	1, 2, 4, 8V/V	16-Pin Plastic DIP	-40°C to +85°C
PGA206UA	1, 2, 4, 8V/V	SOL-16 Surface-Mount	-40°C to +85°C
PGA206U	1, 2, 4, 8V/V	SOL-16 Surface-Mount	-40°C to +85°C
PGA207PA	1, 2, 5, 10V/V	16-Pin Plastic DIP	-40°C to +85°C
PGA207P	1, 2, 5, 10V/V	16-Pin Plastic DIP	-40°C to +85°C
PGA207UA	1, 2, 5, 10V/V	SOL-16 Surface-Mount	-40°C to +85°C
PGA207U	1, 2, 5, 10V/V	SOL-16 Surface-Mount	-40°C to +85°C



## ELECTROSTATIC DISCHARGE SENSITIVITY

This integrated circuit can be damaged by ESD. Burr-Brown recommends that all integrated circuits be handled with appropriate precautions. Failure to observe proper handling and installation procedures can cause damage.

ESD damage can range from subtle performance degradation to complete device failure. Precision integrated circuits may be more susceptible to damage because very small parametric changes could cause the device not to meet its published specifications.

# TYPICAL PERFORMANCE CURVES

At  $T_A = +25^\circ\text{C}$ , and  $V_S = \pm 15\text{V}$ , unless otherwise noted.

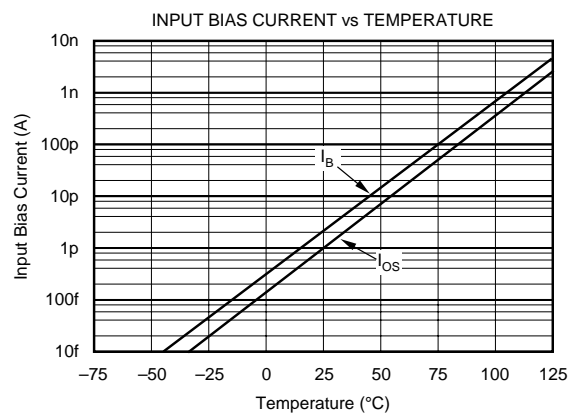
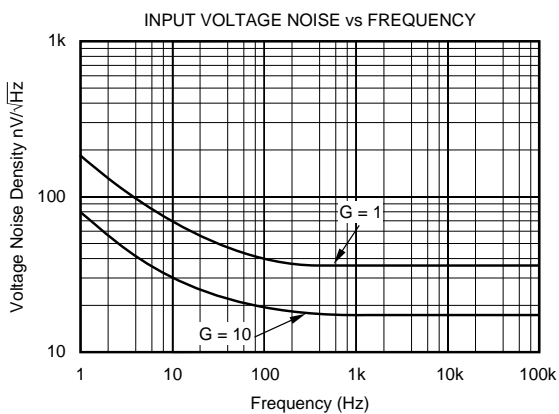
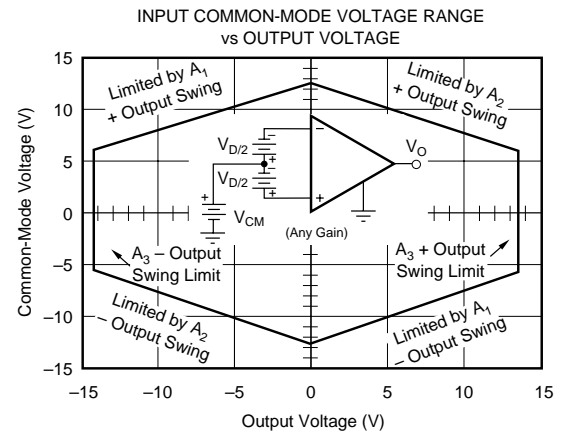
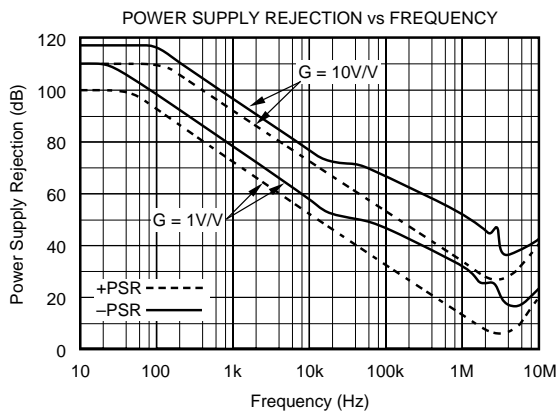
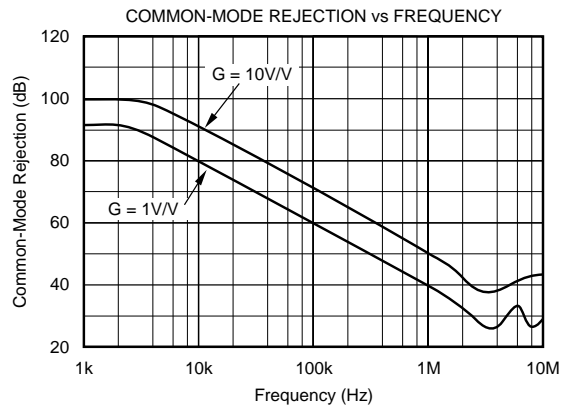
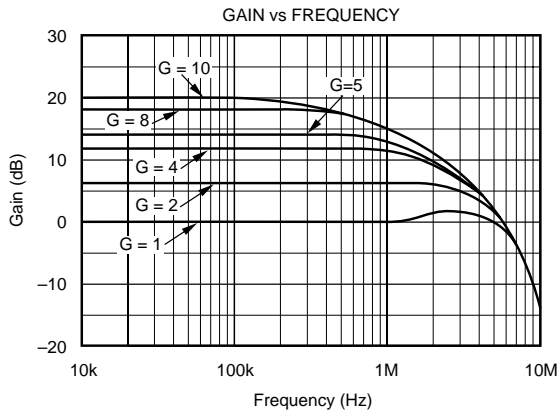

# TYPICAL PERFORMANCE CURVES (CONT)

At  $T_A = +25^\circ\text{C}$ , and  $V_S = \pm 15\text{V}$ , unless otherwise noted.

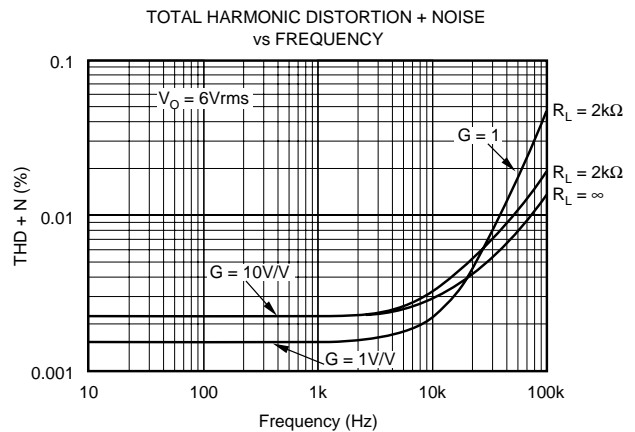
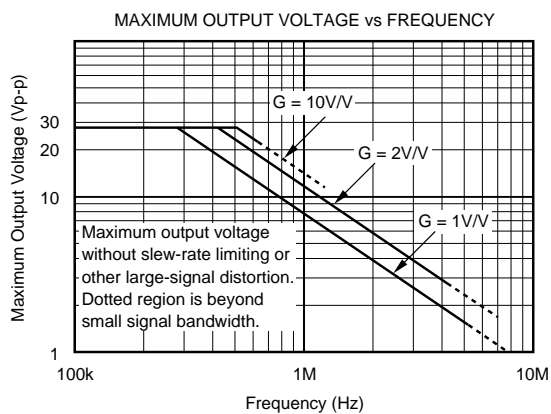
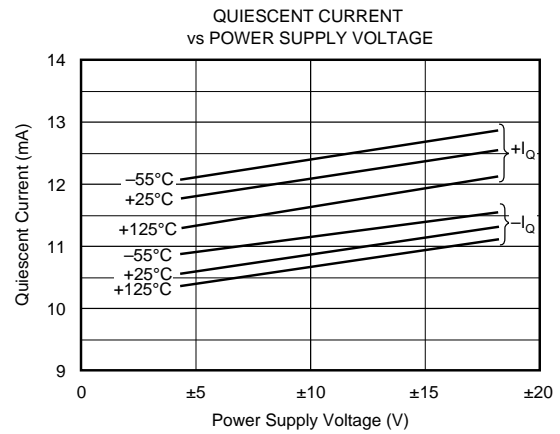
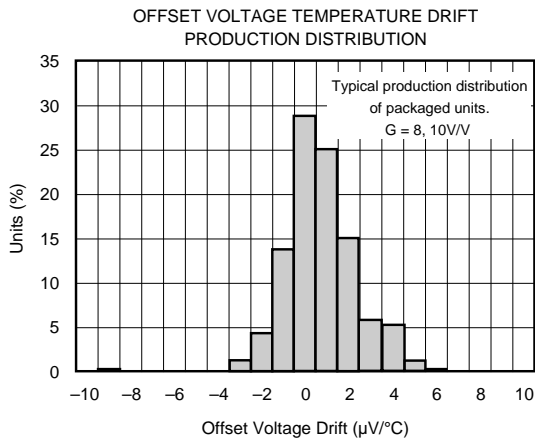
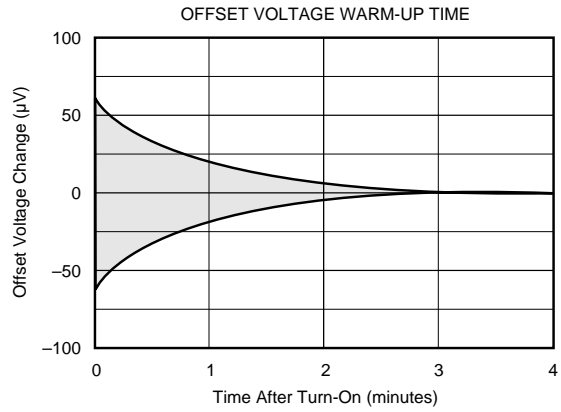
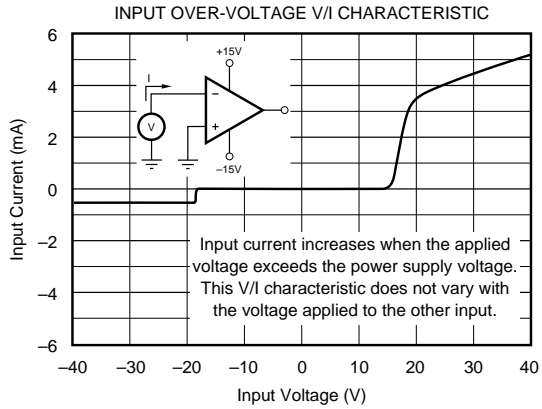

# TYPICAL PERFORMANCE CURVES (CONT)

At  $T_A = +25^\circ\text{C}$ , and  $V_S = \pm 15\text{V}$ , unless otherwise noted.

SMALL SIGNAL RESPONSE  
 $G = 1$ ,  $C_L = 50\text{pF}$

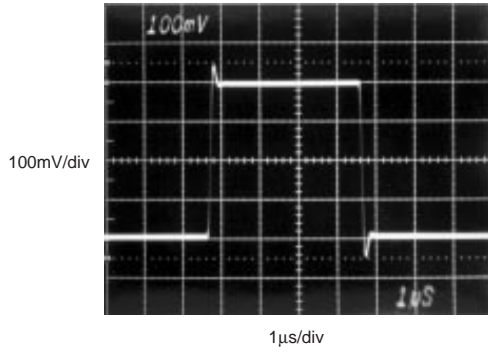

SMALL SIGNAL RESPONSE  
 $G = 10$ ,  $C_L = 50\text{pF}$

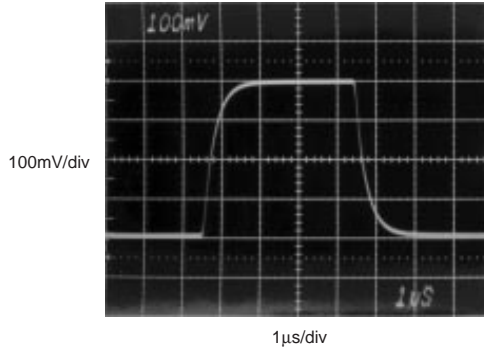

LARGE SIGNAL RESPONSE  
 $G = 1$ ,  $C_L = 50\text{pF}$

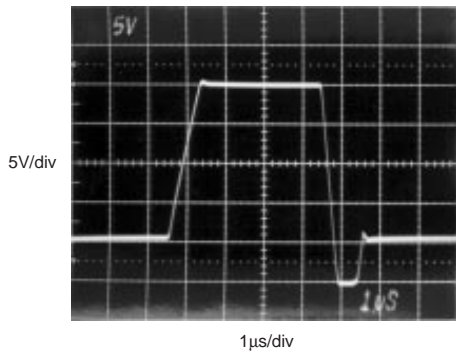

LARGE SIGNAL RESPONSE  
 $G = 10$ ,  $C_L = 50\text{pF}$

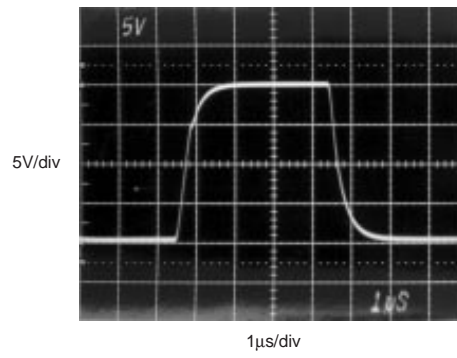

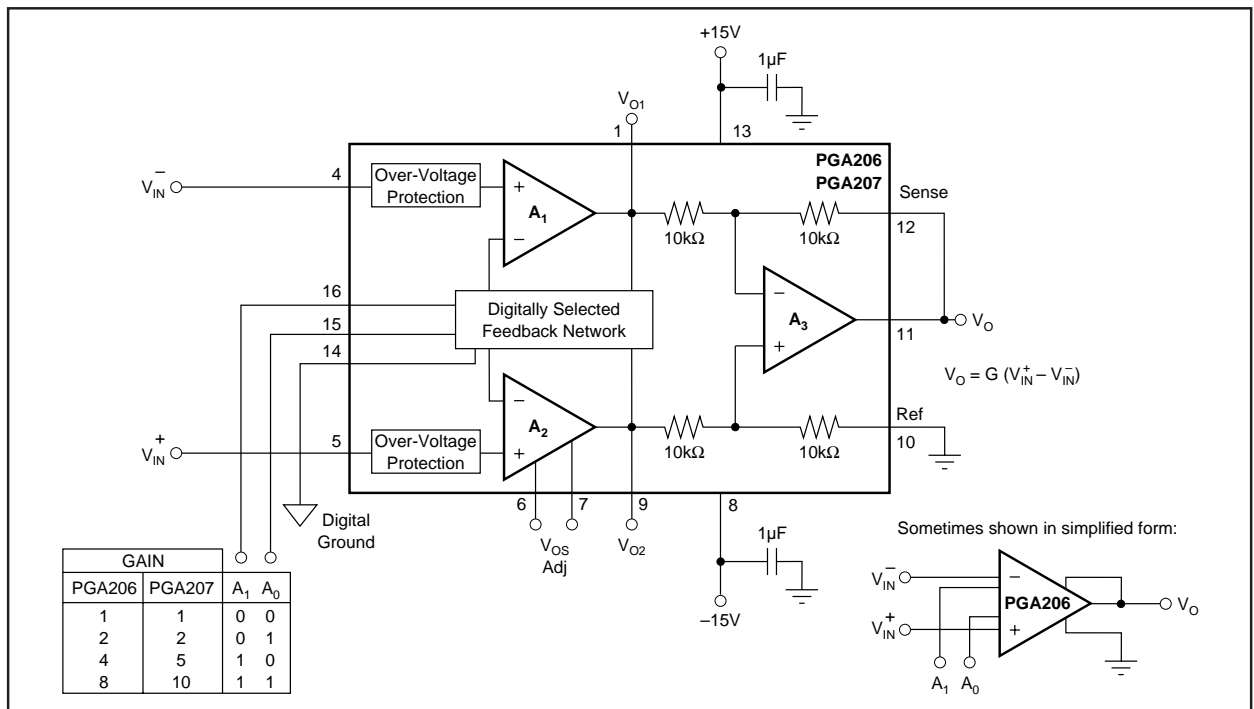

FIGURE 1. Basic Connections.

## APPLICATIONS INFORMATION

Figure 1 shows the circuit diagram for basic operation of the PGA206 or PGA207. Applications with noisy or high impedance power supplies may require decoupling capacitors close to the device pins as shown.

The output is referred to the output reference (Ref) terminal which is normally grounded. This must be a low-impedance connection to assure good common-mode rejection. A resistance of 2Ω in series with the Ref pin will cause a typical device to degrade to approximately 80dB CMR ( $G = 1$ ).

The output sense connection (pin 12) must be connected to the output terminal (pin 11) for proper operation. This connection can be made at the load for best accuracy.

### DIGITAL INPUTS

The digital inputs  $A_0$  and  $A_1$  select the gain according to the logic table in Figure 1. Logic “1” is defined as a voltage greater than 2V above digital ground potential (pin 14). Digital ground can be connected to any potential ranging from the  $V^-$  power supply to 4V less than  $V^+$ . Digital ground is usually equal to analog ground potential and the two grounds are connected at the power supply. The digital inputs interface directly to CMOS and TTL logic.

A nearly constant current of approximately 1.2mA flows in the digital ground pin. It is good practice to return digital ground through a separate connection path so that analog ground is not affected by the digital ground current.

The digital inputs,  $A_0$  and  $A_1$ , are not latched. A change in logic input immediately selects a new gain. Switching time of the logic is approximately 500ns. The time to respond to gain change is equal to switching time, plus the time it takes the amplifier to settle to a new output voltage in the newly selected gain (see settling time specifications).

Many applications use an external logic latch to acquire gain control data from a high speed digital bus. Using an external latch isolates the high speed digital bus from sensitive analog circuitry. Locate the digital latch as far as practical from analog circuitry to avoid coupling digital noise into analog input circuitry.

### OFFSET VOLTAGE ADJUSTMENT

The PGA206 and PGA207 are laser trimmed for very low offset voltage and drift. Many applications require no external offset adjustment. Multiplexed data acquisition systems generally correct offset by grounding the inputs of one channel to measure offset voltage. Stored offset values for each gain are then subtracted from subsequent readings of other channels.

Figure 2 shows optional offset voltage trim circuits. Offset voltage changes with the selected gain. To adjust for low offset voltage in all gains, both input and output offsets must be trimmed.





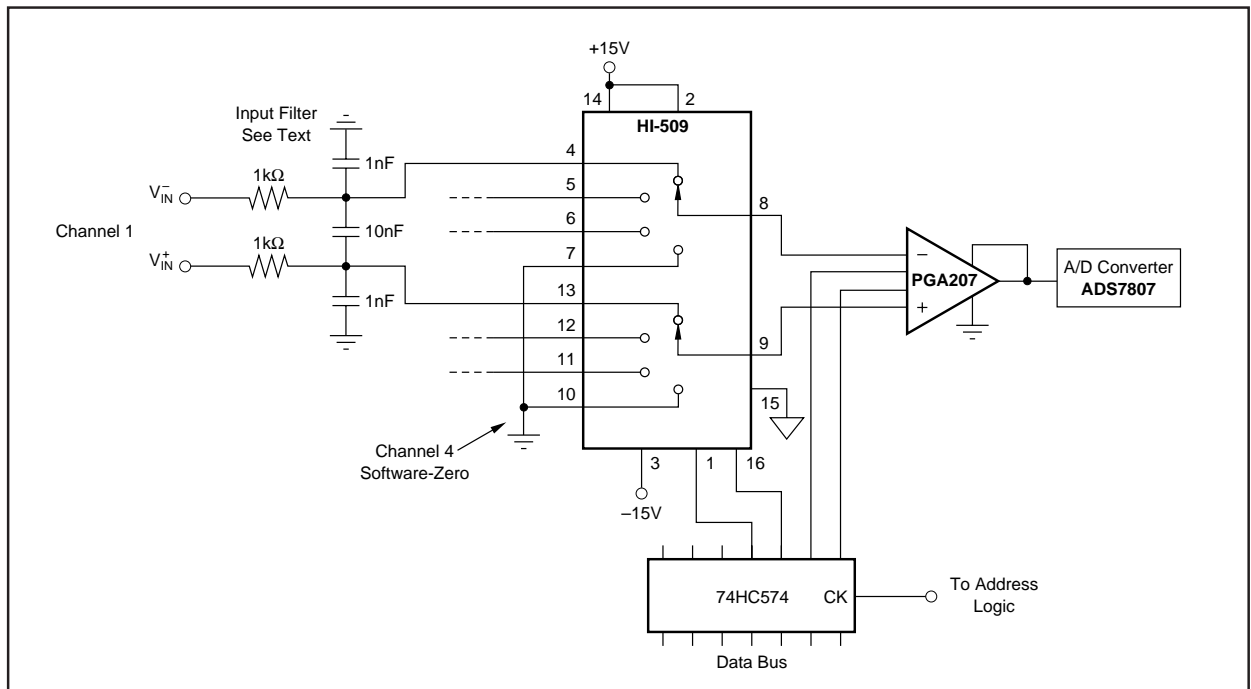

FIGURE 4. Multiplexed-Input Signal Acquisition System.

### INPUT COMMON-MODE RANGE

The linear input voltage range of the PGA206 and PGA207 is from approximately 2.3V below the positive supply voltage to 1.5V above the negative supply. As a differential input voltage causes output voltage to increase, however, the linear input range is limited by the output voltage swing of amplifiers  $A_1$  and  $A_2$ . So the linear common-mode input range is related to the output voltage of the complete amplifier. This behavior also depends on supply voltage—see performance curves “Input Common-Mode Range vs Output Voltage”.

Input overload can produce an output voltage that appears normal. For example, if an input overload condition drives both input amplifiers to their positive output swing limit, the difference voltage measured by the output amplifier will be near zero. The output of the PGA206 or PGA207 will be near 0V even though both inputs are overloaded. This condition can be detected by sensing the voltage on the  $V_{01}$  and  $V_{02}$  pins to determine whether they are within their linear operating range.

### INPUT PROTECTION

The inputs of the PGA206 and PGA207 are individually protected for voltages up to  $\pm 40V$ . For example, a condition of  $-40V$  on one input and  $+40V$  on the other input will not cause damage. Internal circuitry on each input provides low series impedance under normal signal conditions. If the input is overloaded, the protection circuitry limits the input current to a safe value. The typical performance curve “Input Overload V/I Characteristic” shows this behavior. The inputs are protected even if no power supply voltage is applied.

### MULTIPLEXED INPUTS

The PGA206 and PGA207 are ideally suited for multiple channel data acquisition. Figure 4 shows a typical application with an analog multiplexer used to connect one of four differential input signals to a single PGA207.

Careful circuit layout will help preserve accuracy of multiplexed signals. Run the inverting and non-inverting connections of each channel parallel to each other over a ground plane, or directly adjacent on top and bottom of the circuit board. Grounded guard traces between channels help reduce stray signal pick-up.

Multiplexed signals from high impedance sources require special care. As inputs are switched by the multiplexer, charge can be injected into the source, disturbing the input signal. Since many such sources involve slow signals, a simple R/C filter at the input can be used to dramatically reduce this effect. The arrangement shown filters both the differential signal and common-mode noise.

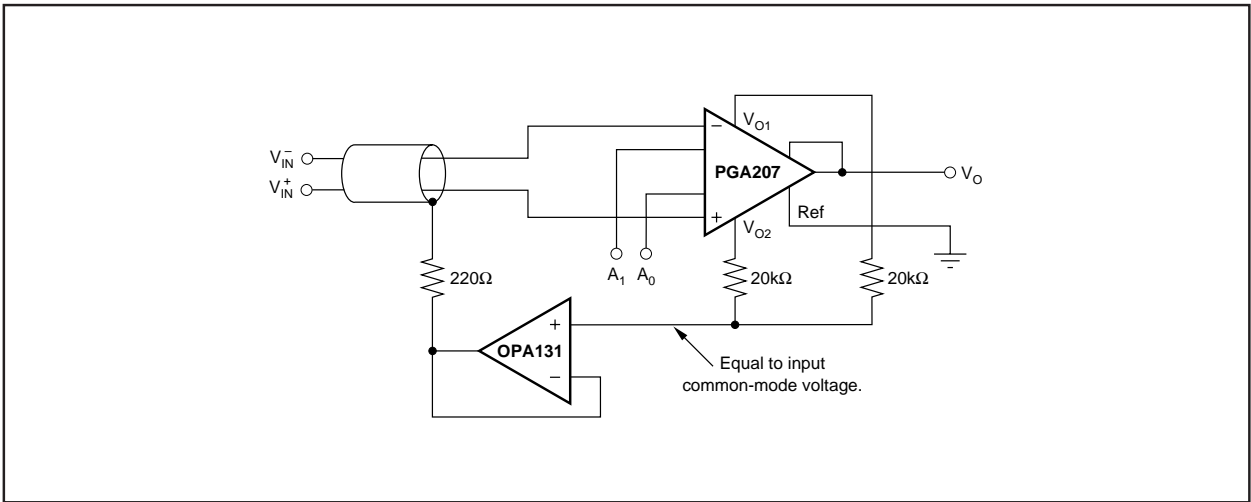

FIGURE 5. Shield Drive Circuit.

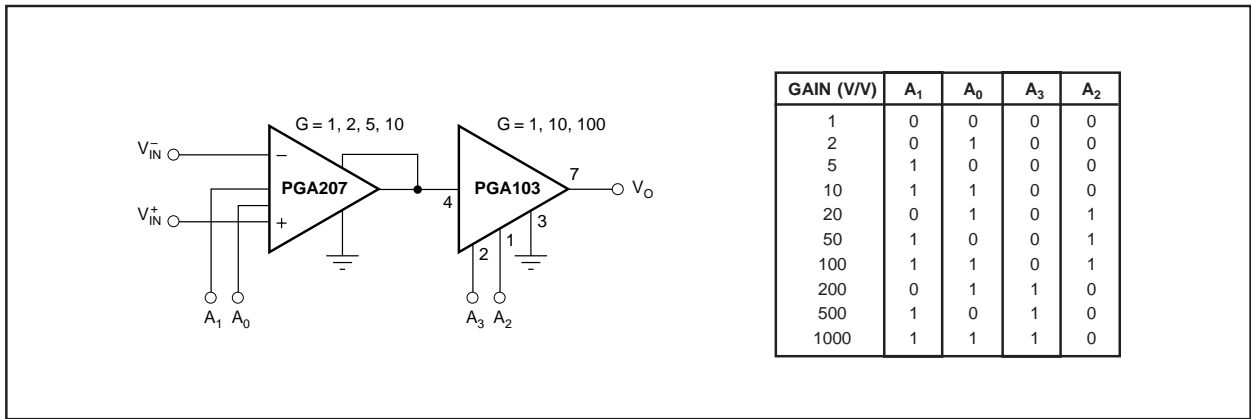

FIGURE 6. Wide Gain Range Programmable IA.