



REG1118

800mA Low Dropout Positive Regulator with Current Source and Sink Capability

FEATURES

- SOURCES 800mA, SINKS 400mA
- 2.85V OUTPUT FOR SCSI ACTIVE NEGATION TERMINATION
- 1.3V max DROPOUT VOLTAGE AT $I_o = 800mA$
- INTERNAL CURRENT LIMIT
- THERMAL OVERLOAD PROTECTION
- SOT-223 SURFACE MOUNT PACKAGE

APPLICATIONS

- SCSI-2 AND SCSI-3 DEVICES
- FAST-20 SCSI
- ACTIVE NEGATION SCSI TERMINATORS
- SUPPLY SPLITTER GROUND GENERATION

DESCRIPTION

The REG1118-2.85 is a three-terminal voltage regulators capable of sourcing up to 800mA and sinking up to 400mA. The sinking capability is important in SCSI applications where active negation line drivers are used. The REG1118-2.85 is useful for making a 27-line Boulay terminator capable of interfacing with active negation drivers required in FAST-20 SCSI applications. The regulator has active current limits for both sink and source currents as well as internal thermal limiting.

Laser trimming assures excellent output voltage accuracy. An NPN output stage allows output stage drive current to contribute to the source load current for maximum efficiency.

REG1118 is packaged in a SOT-223 surface-mount package, suitable for reflow soldering techniques.

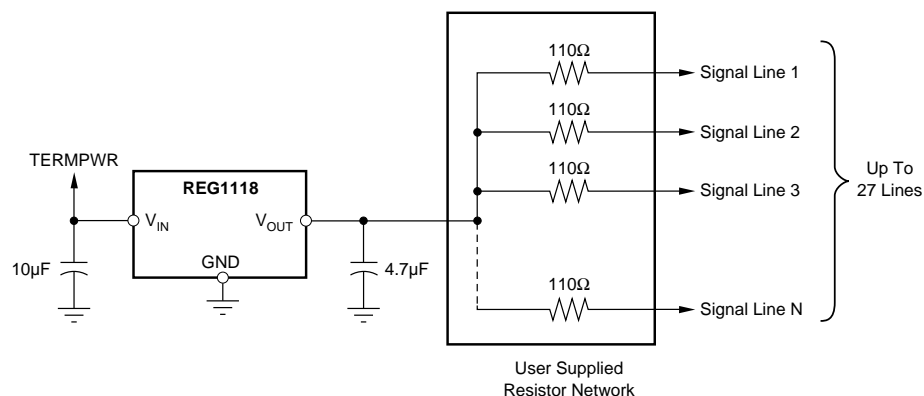

REG1118-2.85 Used to Make Active Negation SCSI Terminator

SPECIFICATIONS

At $T_A = 0^\circ\text{C}$ to 70°C , $\text{TERMPWR} = +5\text{V}$, unless otherwise noted.

PARAMETER	CONDITIONS	REG1118-2.85			UNITS
		MIN	TYP	MAX	
OUTPUT VOLTAGE	No Load, $T_A = 25^\circ\text{C}$ All Operating Conditions ⁽¹⁾	2.82	2.85	2.88	V
		2.79	2.85	2.91	V
LINE REGULATION ⁽²⁾	$I_O = 0$, $V_{IN} = 4.75\text{V}$ to 6V		0.3	4	mV
LOAD REGULATION ⁽²⁾	$I_O = 0$ to 800mA $I_O = -400$ to 0mA		2	25	mV
			25	60	mV
DROPOUT VOLTAGE ⁽³⁾	$T_A = 25^\circ\text{C}$ $I_O = 100\text{mA}$ $I_O = 800\text{mA}$		0.8	1.1	V
			1.1	1.3	V
CURRENT LIMIT Positive (I_{SC+}) ⁽⁴⁾ Negative (I_{SC-})	$T_A = 25^\circ\text{C}$ $V_{OUT} = 3.7\text{V}$	800	1450	-400	mA
			-750		mA
QUIESCENT CURRENT	$I_O = 0$		3	7	mA
RIPPLE REJECTION	$T_A = 25^\circ\text{C}$ $f = 120\text{Hz}$, $V_{IN} - V_{OUT} = 2\text{V}$, $V_{RIPPLE} = 0.5\text{Vp-p}$		56		dB
LONG-TERM STABILITY	$T_A = +125^\circ\text{C}$, 1000Hr		0.2		%
THERMAL SHUTDOWN Junction Temperature Shutdown Junction Temperature Reset			150		$^\circ\text{C}$
			140		$^\circ\text{C}$
THERMAL RESISTANCE Specified Junction Temperature Range Operating Junction Temperature Range Storage Range Thermal Resistance θ_{JC}	(Junction-to-Case at Tab)	0		70	$^\circ\text{C}$
		0		125	$^\circ\text{C}$
		-55		125	$^\circ\text{C}$
			15		$^\circ\text{C/W}$

NOTES: (1) All operating conditions include the combined effects of load current, input voltage, and temperature over each parameter's full specified range. (2) Load and line regulation are tested at a constant junction temperature by low duty cycle testing. (3) Dropout voltage is defined as the minimum input-to-output voltage that produces a 1% decrease in output voltage. (4) V_{OUT} to ground through 1Ω .

ABSOLUTE MAXIMUM RATINGS

Input Voltage	7V
Output Voltage	-0.2V to (V+) +0.5V
Short-Circuit Duration	Indefinite
Operating Junction Temperature Range	0°C to $+125^\circ\text{C}$
Storage Temperature Range	-55°C to $+125^\circ\text{C}$
Lead Temperature (soldering, 10s) ⁽¹⁾	$+300^\circ\text{C}$

NOTE: (1) See "Soldering Methods."

PACKAGE INFORMATION

PRODUCT	PACKAGE	PACKAGE DRAWING NUMBER ⁽¹⁾
REG1118-2.85	SOT-223	311

NOTE: (1) For detailed drawing and dimension table, please see end of data sheet, or Appendix C of Burr-Brown IC Data Book.

ORDERING INFORMATION

PRODUCT ⁽¹⁾	PART MARKING	PACKAGE
REG1118-2.85	BB11182	SOT-223

NOTE: (1) Available in Tape and Reel, add -TR to Model Number.

CONNECTION DIAGRAM

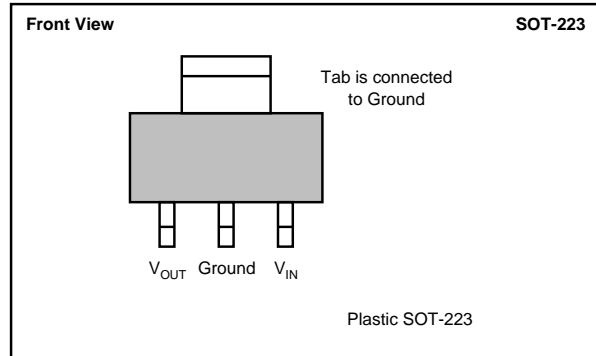

ELECTROSTATIC DISCHARGE SENSITIVITY

This integrated circuit can be damaged by ESD. Burr-Brown recommends that all integrated circuits be handled with appropriate precautions. Failure to observe proper handling and installation procedures can cause damage.

TYPICAL PERFORMANCE CURVE

At $T_A = 25^\circ\text{C}$, $\text{TERMPWR} = +5\text{V}$, unless otherwise specified.

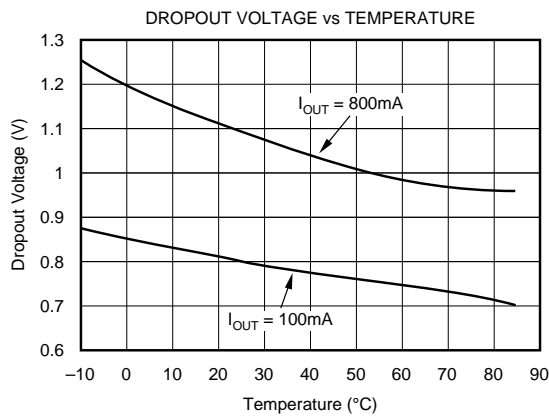
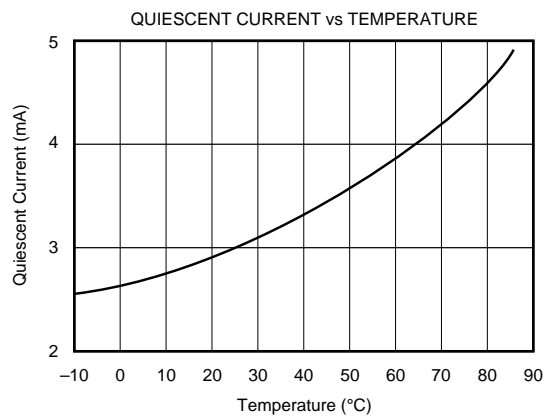
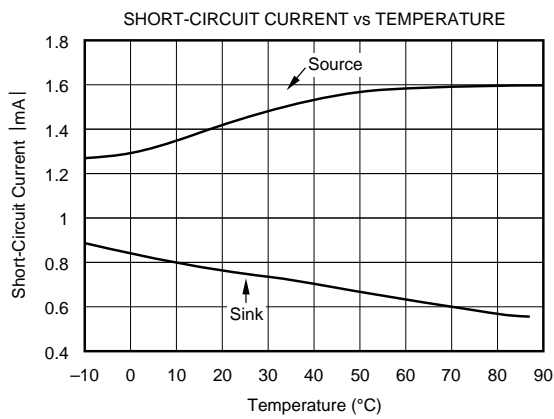
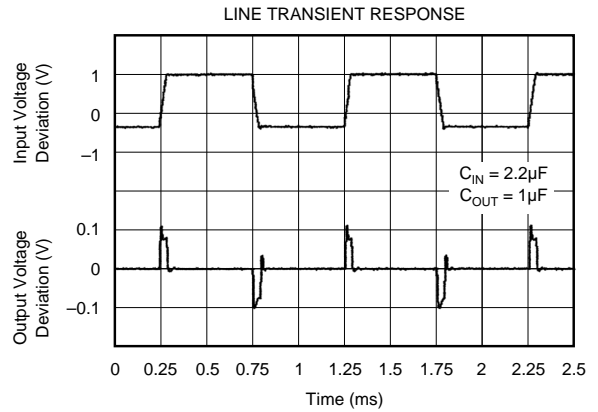
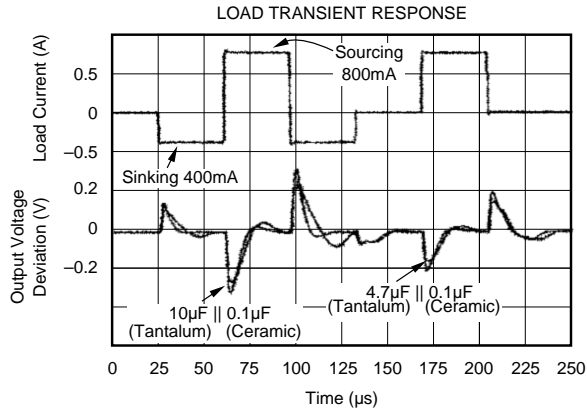

APPLICATIONS INFORMATION

Figure 1 shows the basic hookup diagram for the REG1118. An output capacitor is required for proper operation and to improve high frequency load regulation. A high quality capacitor should be used to assure that the ESR (effective series resistance) is less than 0.5Ω . A capacitor of at least $1\mu\text{F}$ is recommended. Increasing C_{OUT} improves output voltage deviation, see the typical curve "Load Transient Response." It is suggested that the input be decoupled with $10\mu\text{F}$ low ESR capacitor.

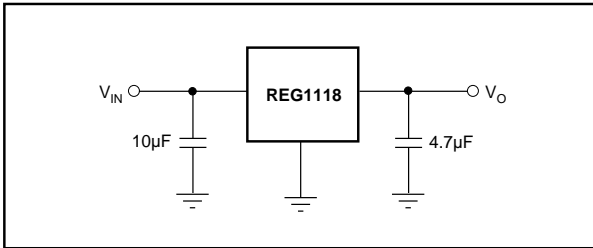

FIGURE 1. Basic Connections.

THERMAL CONSIDERATIONS

The REG1118 has current limit and thermal shutdown circuits that protect it from overload. The thermal shutdown activates at approximately $T_J = 150^\circ\text{C}$. For continuous operation, however, the junction temperature should not be allowed to exceed 125°C . Any tendency to activate the thermal shutdown in normal use is an indication of an inadequate heat sink or excessive power dissipation. The power dissipation is equal to:

$$P_D = (V_{\text{IN}} - V_{\text{OUT}}) I_{\text{OUT}}$$

The junction temperature can be calculated by:

$$T_J = T_A + P_D (\theta_{JA})$$

where T_A is the ambient temperature, and

θ_{JA} is the junction-to-ambient thermal resistance

The REG1118 derives heat sinking from conduction through its copper leads, especially the large mounting tab. These must be soldered to a circuit board with a substantial amount of copper remaining (see Figure 2). Circuit board traces connecting to the tab and the leads should be made as large as practical. Other nearby circuit traces, including those on the back side of the circuit board, help conduct heat away from the device, even though they are not electrically connected. Make all nearby copper traces as wide as possible and leave only narrow gaps between traces. In addition, multiple contacts to internal power and ground planes increase heat sinking with minimal increase in circuit board area.

Table I shows approximate values of θ_{JA} for various circuit board and copper areas. Nearby heat dissipating components, circuit board mounting conditions and ventilation can dramatically affect the actual θ_{JA} .

A simple experiment will determine whether the maximum recommended junction temperature is exceeded in an actual circuit board and mounting configuration: Increase the

ambient temperature above that expected in normal operation until the device's thermal shutdown is activated. If this occurs at more than 40°C above the maximum expected ambient temperature, then the T_J will be less than 125°C during normal operation.

SOLDERING METHODS

The REG1118 package is suitable for infrared reflow and vapor-phase reflow soldering techniques. The high rate of temperature change that occurs with wave soldering, or hand soldering can damage the REG1118.

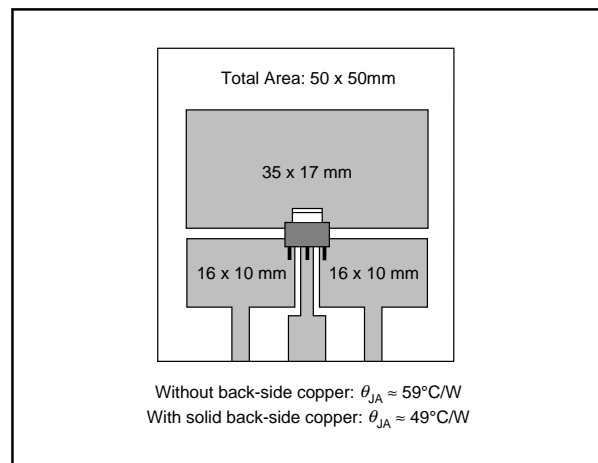

FIGURE 2. Circuit Board Layout Example.

TOTAL PC BOARD AREA	TOPSIDE ⁽¹⁾ COPPER AREA	BACKSIDE COPPER AREA	THERMAL RESISTANCE JUNCTION-TO-AMBIENT
2500mm ²	2500mm ²	2500mm ²	46°C/W
2500mm ²	1250mm ²	2500mm ²	47°C/W
2500mm ²	950mm ²	2500mm ²	49°C/W
2500mm ²	2500mm ²	0	51°C/W
2500mm ²	1800mm ²	0	53°C/W
1600mm ²	600mm ²	1600mm ²	55°C/W
2500mm ²	1250mm ²	0	58°C/W
2500mm ²	915mm ²	0	59°C/W
1600mm ²	600mm ²	0	67°C/W
900mm ²	340mm ²	900mm ²	72°C/W
900mm ²	340mm ²	0	85°C/W

NOTE: (1) Tab is attached to the topside copper.

TABLE I.

INSPEC Abstract Number: B91007604, C91012627
 Kelly, E.G. "Thermal Characteristics of Surface 5WK9Ω Packages." The Proceedings of SMTCON. Surface Mount Technology Conference and Exposition: *Competitive Surface Mount Technology*, April 3-6, 1990, Atlantic City, NJ, USA. Abstract Publisher: IC Manage, 1990, Chicago, IL, USA.

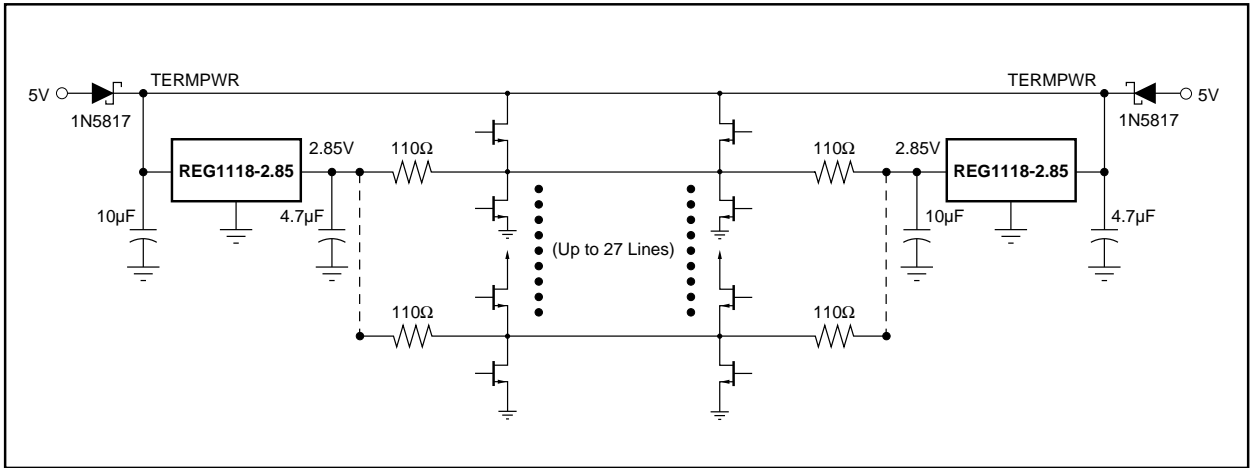

FIGURE 3. SCSI Active Termination Configuration.

The information provided herein is believed to be reliable; however, BURR-BROWN assumes no responsibility for inaccuracies or omissions. BURR-BROWN assumes no responsibility for the use of this information, and all use of such information shall be entirely at the user's own risk. Prices and specifications are subject to change without notice. No patent rights or licenses to any of the circuits described herein are implied or granted to any third party. BURR-BROWN does not authorize or warrant any BURR-BROWN product for use in life support devices and/or systems.