

ES1A Thru ES1G

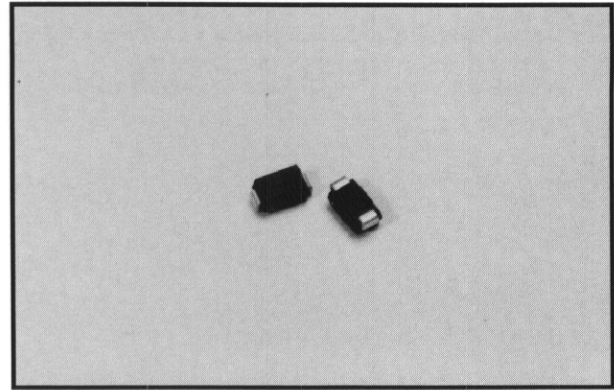

1 AMP SURFACE MOUNT GLASS SUPER FAST RECOVERY RECTIFIER



FEATURES

- Super fast recovery time
- For surface mount applications
- Reliable low cost construction utilizing molded plastic technique
- Low forward voltage drop
- UL recognized 94V-O plastic material
- High temperature soldering: 250 °C/10 seconds at terminals
- Glass passivated junction

Mechanical Data

- Case: Molded plastic
- Polarity: Indicated on cathode
- Weight: 0.021 ounces, 0.064 grams

Outline Drawing

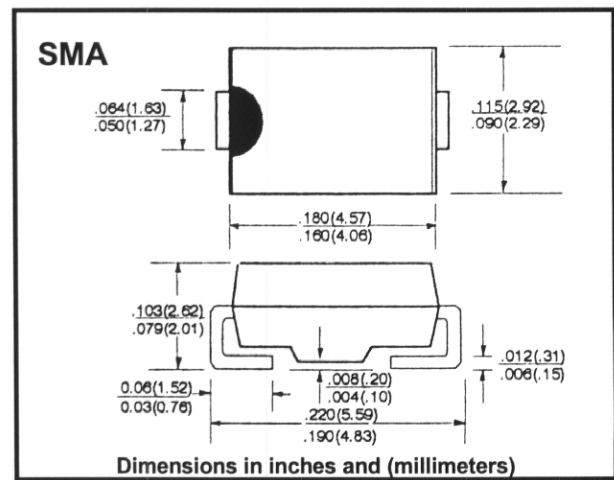

Maximum Ratings & Characteristics

- Ratings at 25° C ambient temperature unless otherwise specified
- Single phase, half wave, 60Hz, resistive or inductive load
- For capacitive load, derate current by 20%

		ES1A	ES1B	ES1C	ES1D	ES1G	Units
Maximum Recurrent Peak Reverse Voltage	V_{RRM}	50	100	150	200	400	V
Maximum RMS Input Voltage	V_{RMS}	35	70	105	140	280	V
Maximum DC Blocking Voltage	V_{DC}	50	100	150	200	400	V
Maximum Average Forward Output Current .375" 9.5mm lead length @ $T_L = 110^\circ\text{C}$	$I_{(AV)}$	1.0					A
Peak Forward Surge Current 8.3 ms Single Half-Sine-Wave Superimposed On Rated Load	I_{FSM}	30					A
Maximum Forward Voltage Drop At 0.6A At 1.0A	V_F	0.90 0.98			1.25		V
Maximum Reverse Current At Rated DC Blocking Voltage per Bridge Element @ $T_A = 25^\circ\text{C}$ @ $T_A = 100^\circ\text{C}$	I_R	5 200					μA μA
Maximum Reverse Recovery Time* (See Note)	t_{rr}	20					nS
Typical Junction Capacitance** (See Note)	C_J	10					pF
Typical Thermal Resistance*** (See Note)	$R_{(THJL)}$	25					$^\circ\text{C/W}$
Operating Temperature Range	T_J	-65 to +150					$^\circ\text{C}$
Storage Temperature Range	T_{STG}	-65 to +150					$^\circ\text{C}$

Note: *Test conditions: $I_F=0.5\text{A}$, $I_R = 1.0\text{A}$, $I_{rr} = 0.25\text{A}$

**Measured at 1.0 MHz and applied reverse voltage of 4.0V DC

***Thermal resistance junction to lead measured on PC board 5.0mm² X (0.013mm thick)