



ES2A Thru ES2D

2 AMP SURFACE MOUNT GLASS SUPER FAST RECOVERY RECTIFIER

FEATURES

- For surface mount applications
- Super fast recovery time
- Reliable low cost construction utilizing molded plastic technique
- Low forward voltage drop
- UL recognized 94V-O plastic material
- High temperature soldering: 250 °C/10 seconds at terminal
- Glass passivated junction

Mechanical Data

- Case: Molded plastic
- Polarity: Indicated on cathode
- Weight: 0.003 ounces, 0.093 grams

Maximum Ratings & Characteristics

- Ratings at 25° C ambient temperature unless otherwise specified
- Single phase, half wave, 60Hz, resistive or inductive load
- For capacitive load, derate current by 20%

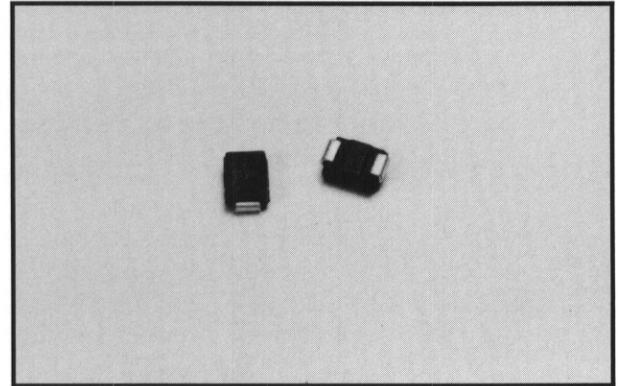

Outline Drawing

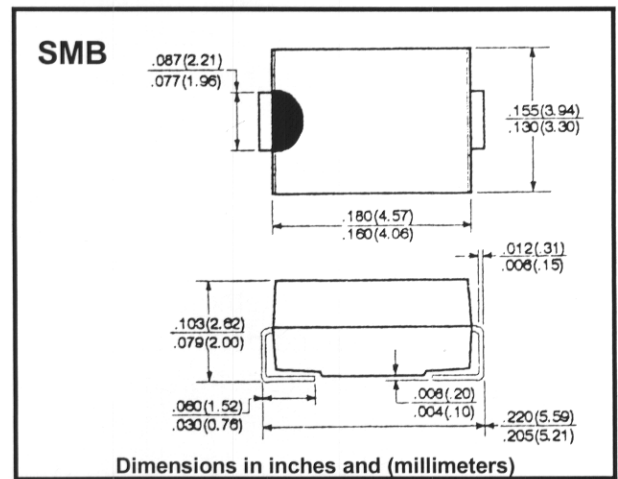

		ES2A	ES2B	ES2C	ES2D	Units
Maximum Recurrent Peak Reverse Voltage	V _{RRM}	50	100	150	200	V
Maximum RMS Input Voltage	V _{RMS}	35	70	105	140	V
Maximum DC Blocking Voltage	V _{DC}	50	100	150	200	V
Maximum Average Forward Output Current .375" 9.5mm lead length @ T _L = 110°C	I _(AV)	2.0				A
Peak Forward Surge Current 8.3 ms Single Half-Sine-Wave Superimposed On Rated Load	I _{FSM}	50				A
Maximum Forward Voltage Drop At 2.0A	V _F	0.9				V
Maximum Reverse Current At Rated DC Blocking Voltage per Bridge Element @ T _A = 25°C	I _R	5				μA
Maximum Reverse Recovery Time* (See Note) @ T _A = 100°C	t _{rr}	350				μA
Typical Junction Capacitance** (See Note)	C _J	25				nS
Maximum Thermal Resistance*** (See Note)	R _(THJL)	20				°C/W
Operating Temperature Range	T _J	-65 to +150				°C
Storage Temperature Range	T _{STG}	-65 to +150				°C

Note: *Test conditions: I_F=0.5A, I_R = 1.0A, I_{rr} = 0.25A

**Measured at 1.0 MHz and applied reverse voltage of 4.0V DC

***Thermal resistance junction to lead measured on PC board 5.0mm² X (0.013mm thick)