

FA7616CP(E)(V)

Bipolar IC
For Switching Power Supply Control

■ Description

The FA7616CP(E)(V) is a bipolar control IC having two channels of PWM-type switching regulator control circuits. With this IC, a DC-to-DC converter can be easily implemented for a minimum input voltage of 1.4V.

■ Features

- Input voltage from 1.4V ($V_{CC} = 1.4$ to 12V)
- Open-collector output
- Wide operating frequency range (f_{osc} : 10 to 500kHz)
- Output ON/OFF control function
- Not many external discrete components are needed

■ Applications

- Battery power supply (two, 1.5V batteries) for portable equipment

■ Block diagram

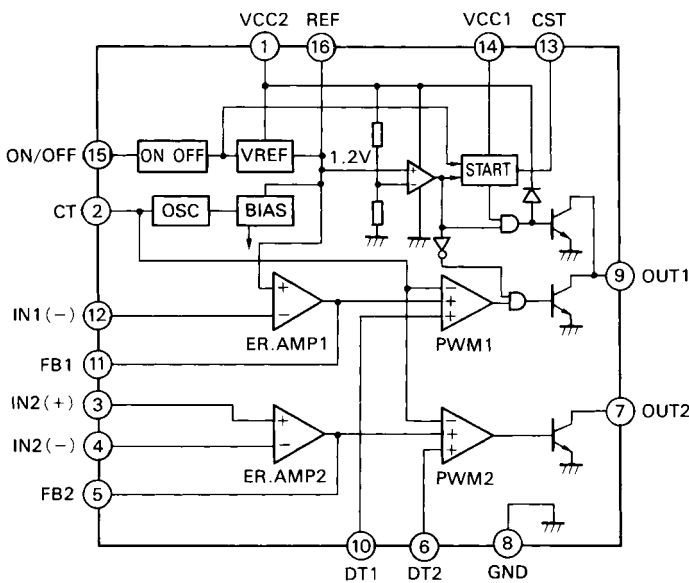

Pin No.	Pin symbol	Description
1	VCC2	IC main power supply
2	CT	Oscillator timing capacitor
3	IN2 (+)	Non-inverting input to error amplifier
4	IN2 (-)	Inverting input to error amplifier
5	FB2	Error amplifier output
6	DT2	Dead time adjustment
7	OUT2	CH. 2 Output
8	GND	Ground
9	OUT1	CH. 1 Output
10	DT1	Dead time adjustment
11	FB1	Error amplifier output
12	IN1 (-)	Inverting input to error amplifier
13	CST	Start-up circuit timing capacitor
14	VCC1	Start-up circuit power supply
15	ON/OFF	Output ON/OFF control
16	REF	Reference voltage output (1.20V)

■ Dimensions, mm

● TSSOP-16

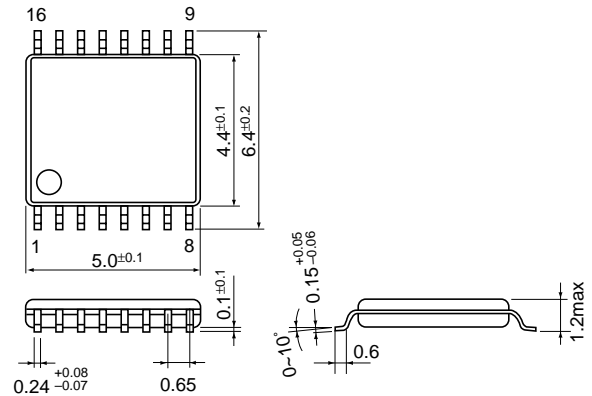

● SSOP-16

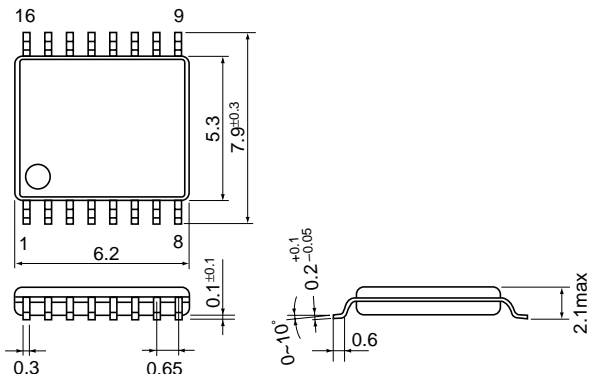

● DIP-16

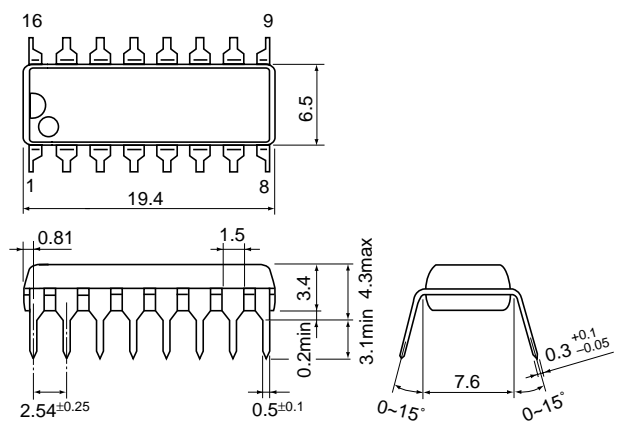

■ Absolute maximum ratings

Item	Symbol	Rating	Unit
Supply voltage	V _{CC}	12	V
Reference voltage output current	I _{OR}	5	mA
Output sink current	I _O	10	mA
Total power dissipation	P _d	300	mW
Operating temperature	T _{opr}	-20 to +85	°C
Storage temperature	T _{stg}	-40 to +150	°C

■ Recommended operating conditions

Item	Symbol	Min.	Max.	Unit
Supply voltage 1	V _{CC1}	1.4	12	V
Supply voltage 2	V _{CC2}	2.5	12	V
Output sink current (at start-up)	I _{SINK}		3	mA
Output sink current (at steady state)	I _{SINK}		5	mA
Oscillation frequency	f _{OSC}	10	500	kHz
Oscillator timing capacitor (start-up circuit)	C _{ST}	47	10,000	μF
Oscillator timing capacitor	C _T	220	10,000	μF
Oscillator timing resistance	R _T	4.7	47	kΩ
Feedback resistance	R _{NF}	100		kΩ

■ Electrical characteristics (T_a = 25°C, V_{CC1} = 1.6V, V_{CC2} = 3V, V_{I5} = 2V, C_T = 1000pF, R_T = 10kΩ)

Reference voltage section

Item	Symbol	Test condition	Min.	Typ.	Max.	Unit
Output voltage	V _{REF}	I _{OR} = 0.1mA	1.196	1.220	1.244	V
Line regulation	LINE	V _{CC} = 2.5 to 12V, V _{I5} = 2V fixed		1	8	mV
Load regulation	LOAD	I _{OR} = 0.1 to 1mA		1	8	mV
Output voltage variation due to temperature change	V _{TC1}	T _a = -20 to +25°C I _{OR} = 0.1mA	-2	-0.3	1	%
	V _{TC2}	T _a = +25 to +85°C I _{OR} = 0.1mA	-2	-0.6	1	%

Oscillator section

Item	Symbol	Test condition	Min.	Typ.	Max.	Unit
Oscillation frequency	f _{OSC}	C _T = 1000pF, R _T = 10kΩ	80	92	110	kHz
Frequency variation 1 (due to supply voltage change)	f _{dV}	V _{CC} = 2.5 to 12V		1	3	%
Frequency variation 2 (due to temperature change)	f _{dT}	T _a = -20 to +85°C		2		%

Error amplifier section

Item	Symbol	Test condition	Min.	Typ.	Max.	Unit
Input offset voltage	V _{IO}			2	10	mV
Input bias current	I _B				1	μA
Common-mode input voltage	V _{CM}		0		V _{CC2} -1.7	V
Open-loop voltage gain	A _V		70			dB
Unity-gain bandwidth	G _B			1.0		MHz
Maximum output voltage	V _{OM+}	R _{NF} = 100kΩ	V _{CC2} -0.5			V
	V _{OM-}	R _{NF} = 100kΩ			200	mV
Output source current	I _{OM+}	V _{OM} = 1V	40	85	170	μA

PWM comparator section

Item	Symbol	Test condition	Min.	Typ.	Max.	Unit
Input threshold voltage	V _{TH0}	Duty cycle = 0%		0.80		V
Input threshold voltage	V _{TH100}	Duty cycle = 100%		1.45		V

Dead time adjustment circuit section

Item	Symbol	Test condition	Min.	Typ.	Max.	Unit
Input threshold voltage	$V_{TH\ DT0}$	Duty cycle = 0%	0.08	0.15		V
Input threshold voltage	$V_{TH\ DT100}$	Duty cycle = 100%		0.80	0.95	V

Output ON/OFF circuit section

Item	Symbol	Test condition	Min.	Typ.	Max.	Unit
ON/OFF threshold voltage	$V_{TH\ ON}$		0.5	0.9	1.2	V
Input current	$I_{I\ ON}$	Pin 15 = 2V		650	850	μA

Start-up circuit section

Item	Symbol	Test condition	Min.	Typ.	Max.	Unit
Oscillation frequency	f_{SC}	$C_{ST} = 1000pF, V_{CC2} = 0.5V$	70	95	115	kHz
ON duty cycle	D_{ST}	$C_{ST} = 1000pF, V_{CC2} = 0.5V$	40	50	60	%
Threshold voltage to stop	$V_{CC2\ TH}$	ON-to-OFF threshold voltage at start-up circuit	2.15	2.30	2.45	V

Output section

Item	Symbol	Test condition	Min.	Typ.	Max.	Unit
Output leakage current	I_{LEAK}	$V_O = 12V$			5	μA
L-level output voltage	V_{OL}	Output sink current = 5mA		0.25	0.55	V

Overall device

Item	Symbol	Test condition	Min.	Typ.	Max.	Unit
Standby current 1	$I_{CC\ ST1}$	Pin 15 = 0V or $V_{CC2} > 2.45V$		0.1	10	μA
Standby current	$I_{CC\ STAR}$	Pin 15 = 2V, $V_{CC2} < 2.15V$		400	800	μA
Standby current 2	$I_{CC\ ST2}$	Pin 15 = 0V, $V_{CC2} = 3V$		0.4	0.7	mA
Operating-state supply current	$I_{CC\ AV}$	Pin 15 = 2V, $V_{CC2} = 3V$		2.2	3.2	mA

■ **Characteristic curves (Ta = 25°C)**

Oscillation frequency (fosc) vs. timing capacitor capacitance (Cst) and output duty cycle
At strat-up state

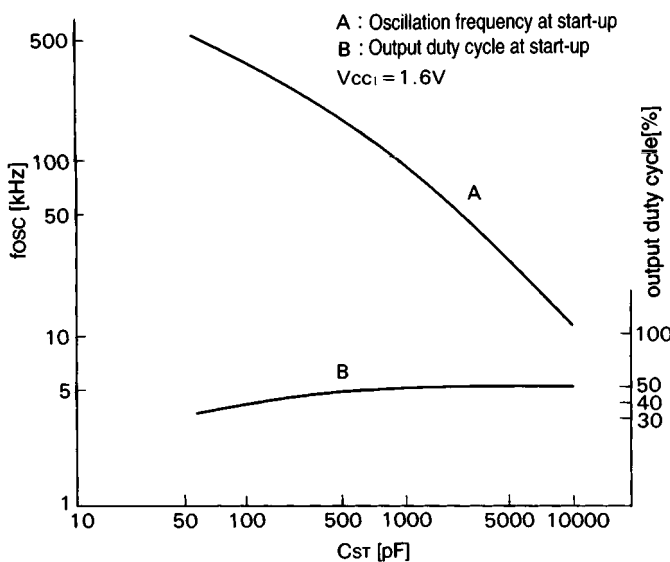

Oscillation frequency (fosc) vs. timing capacitor capacitance (Ct)
At steady state

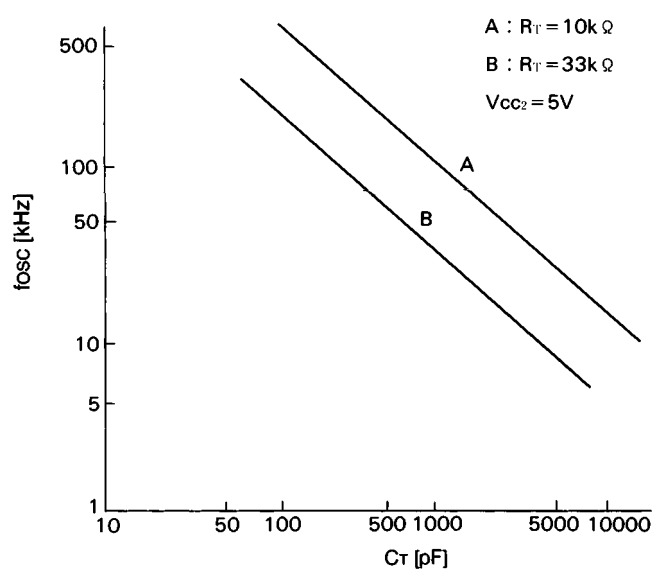

Output duty cycle vs. DT terminal voltage (V_{DT})

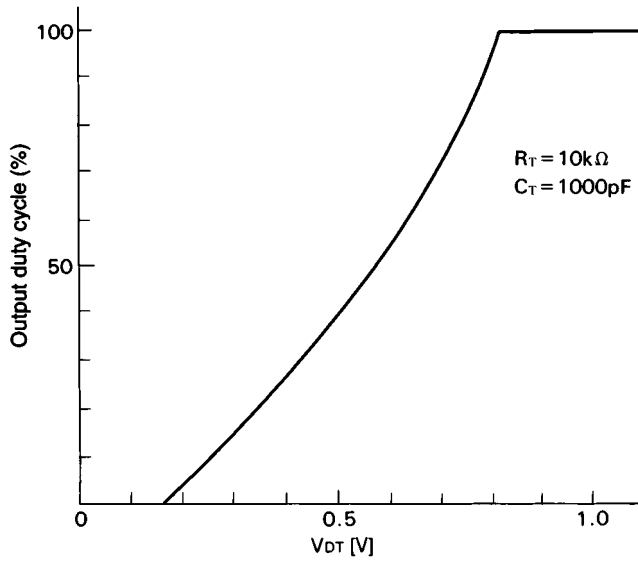

Output duty cycle vs. FB terminal voltage (V_{FB})

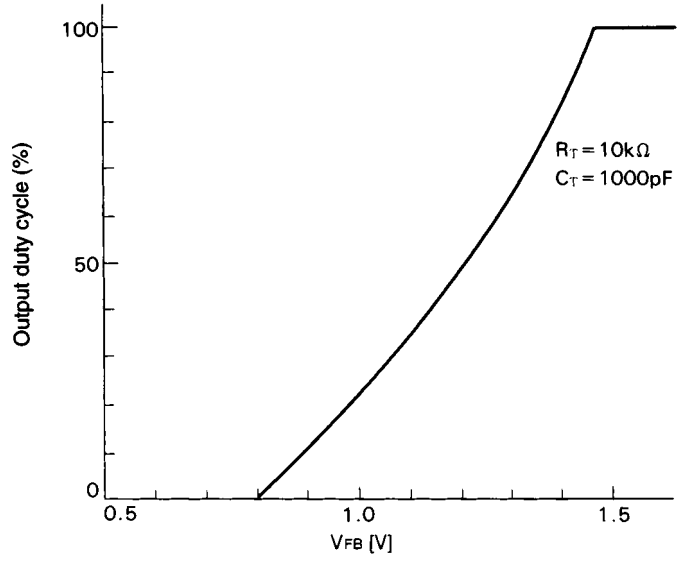

L-level output voltage (V_{OL1}) vs. CH. 1 output sink current (I_{SINK1})

At start-up state

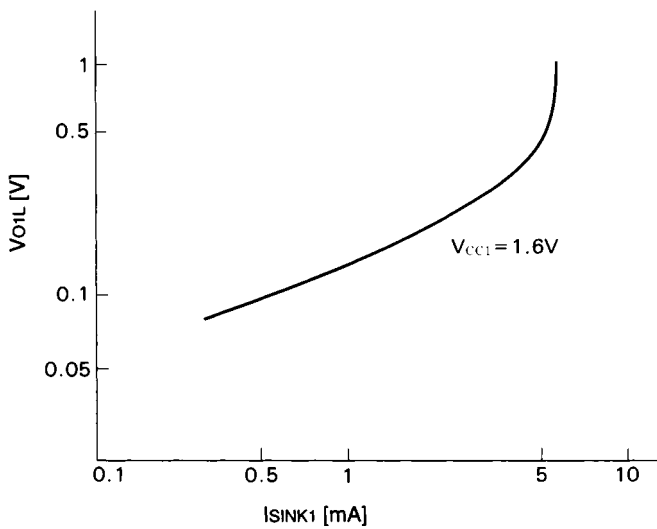

L-level output voltage (V_{OL}) vs. output sink current (I_{SINK})

At steady state

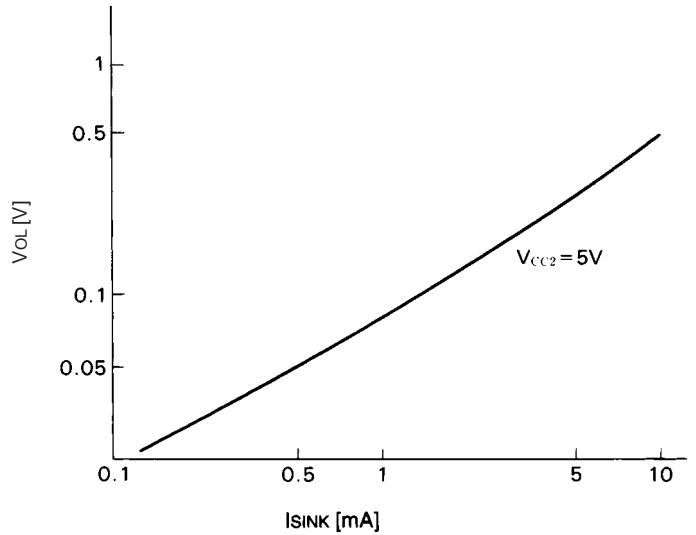

Supply current (I_{CC}) vs. supply voltage (V_{CC})

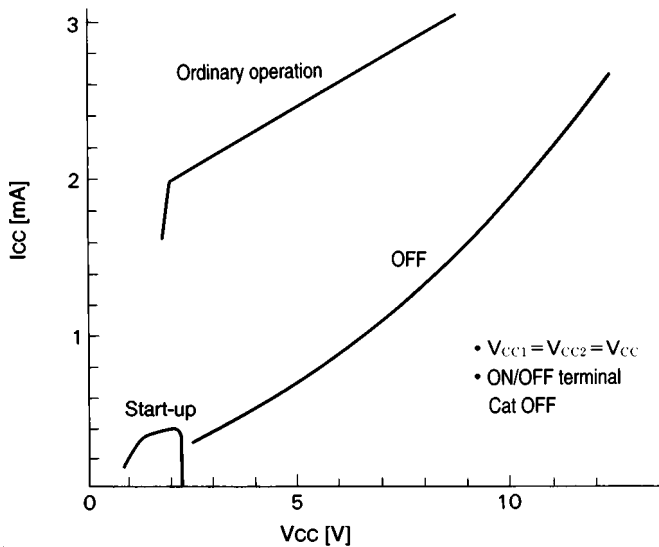

Error amplifier frequency (f) vs. voltage gain (A_v)

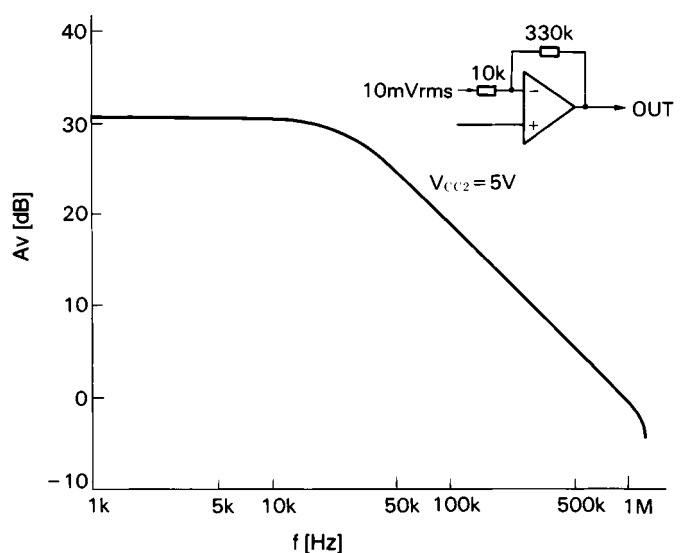

■ Application circuit

● Flyback-transformer type and chopper type boost converter circuit

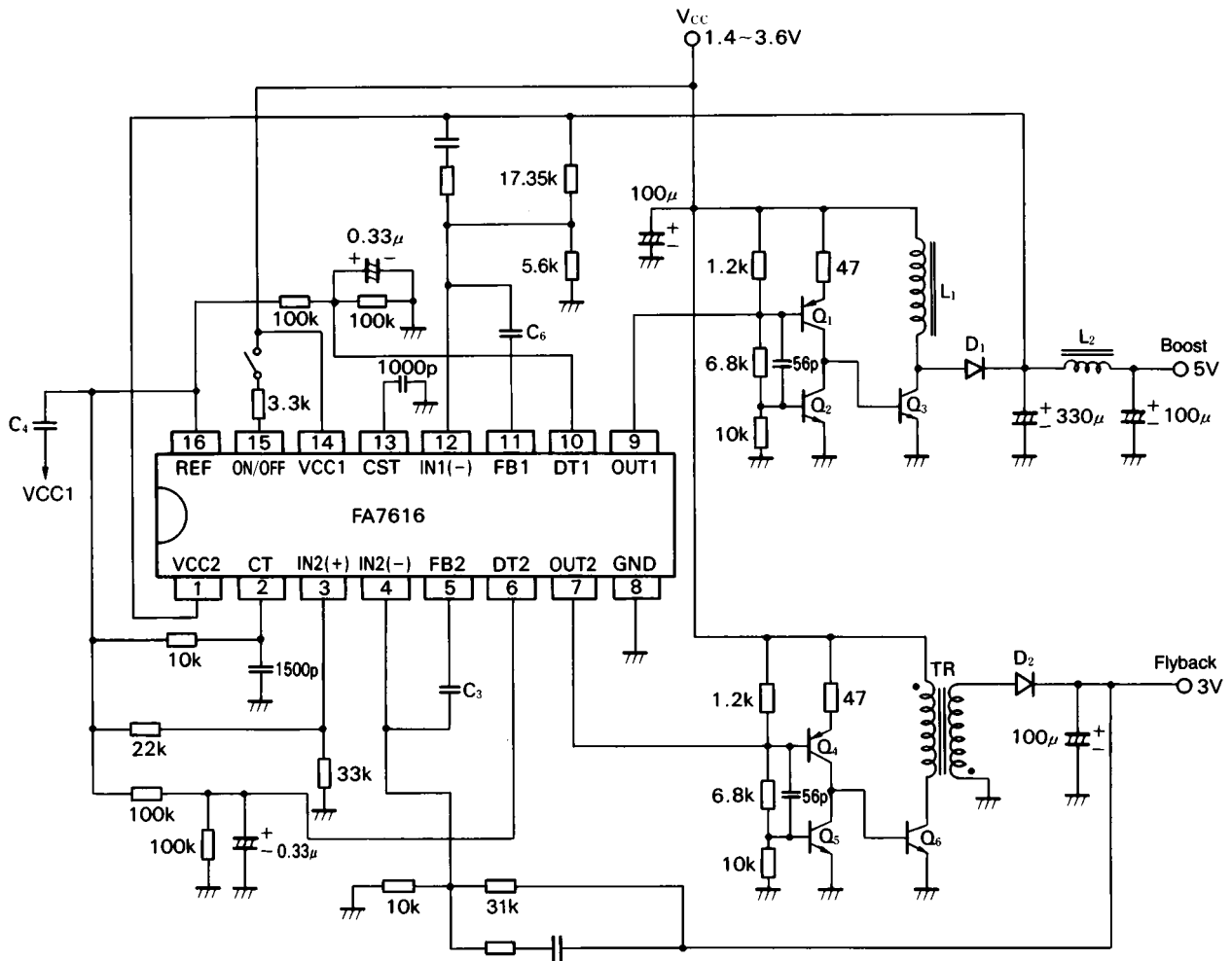

Parts tolerances characteristics are not defined in the circuit design sample shown above. When designing an actual circuit for a product, you must determine parts tolerances and characteristics for safe and economical operation.

Please connect a capacitor, which the value is about 0.01μF to 0.1μF, between VCC and REF terminals in order to prevent from irregular output pulse at start-up.