

N-Channel JFET Low Noise Amplifier



2N4338 – 2N4341

FEATURES

- Exceptionally High Figure of Merit
- Radiation Immunity
- Extremely Low Noise and Capacitance
- High Input Impedance

APPLICATIONS

- Low-level Choppers
- Data Switches
- Multiplexers and Low Noise Amplifiers

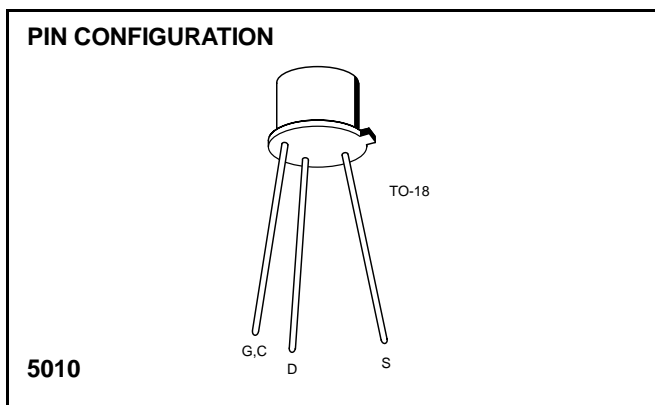

ABSOLUTE MAXIMUM RATINGS

($T_A = 25^\circ\text{C}$ unless otherwise noted)

Gate-Source or Gate-Drain Voltage	-50V
Gate Current	50mA
Storage Temperature Range	-65°C to +200°C
Operating Temperature Range	-55°C to +175°C
Lead Temperature (Soldering, 10sec)	+300°C
Power Dissipation	300mW
Derate above 25°C	2.0mW/°C

NOTE: Stresses above those listed under "Absolute Maximum Ratings" may cause permanent damage to the device. These are stress ratings only and functional operation of the device at these or any other conditions above those indicated in the operational sections of the specifications is not implied. Exposure to absolute maximum rating conditions for extended periods may affect device reliability.

ORDERING INFORMATION

Part	Package	Temperature Range
2N4338-41	Hermetic TO-18	-55°C to +175°C
X2N4338-41	Sorted Chips in Carriers	-55°C to +175°C

ELECTRICAL CHARACTERISTICS ($T_A = 25^\circ\text{C}$ unless otherwise specified)

SYMBOL	PARAMETER	2N4338		2N4339		2N4340		2N4341		UNITS	TEST CONDITIONS
		MIN	MAX	MIN	MAX	MIN	MAX	MIN	MAX		
I_{GSS}	Gate Reverse Current		-0.1		-0.1		-0.1		-0.1	nA	$V_{GS} = -30V, V_{DS} = 0$
		$T_A = 150^\circ\text{C}$	-0.1	-0.1	-0.1	-0.1	-0.1	-0.1	-0.1	μA	
BV_{GSS}	Gate-Source Breakdown Voltage	-50		-50		-50		-50		V	$I_G = -1\mu\text{A}, V_{DS} = 0$
$V_{GS(off)}$	Gate-Source Cutoff Voltage	-0.3	-1	-0.6	-1.8	-1	-3	-2	-6		$V_{DS} = 15V, I_D = 0.1\mu\text{A}$
$I_{D(off)}$	Drain Cutoff Current		0.05 (-5)		0.05 (-5)		0.05 (-5)		0.07 (-10)	nA (V)	$V_{DS} = 15V, V_{GS} = ()$
I_{DSS}	Saturation Drain Current (Note 2)	0.2	0.6	0.5	1.5	1.2	3.6	3	9	mA	$V_{DS} = 15V, V_{GS} = 0$
g_{fs}	Common-Source Forward Transconductance (Note 2)	600	1800	800	2400	1300	3000	2000	4000	μS	$V_{DS} = 15V, V_{GS} = 0$ $f = 1\text{kHz}$
g_{os}	Common-Source Output Conductance		5		15		30		60		
$r_{DS(on)}$	Drain-Source ON Resistance		2500		1700		1500		800	ohm	$V_{DS} = 0, I_{DS} = 0$
C_{iss}	Common-Source Input Capacitance		7		7		7		7	pF	$V_{DS} = 15V, V_{GS} = 0$ (Note 1) $f = 1\text{MHz}$
C_{rss}	Common-Source Reverse Transfer Capacitance		3		3		3		3		
NF	Noise Figure (Note 1)		1		1		1		1	dB	$V_{DS} = 15V, V_{GS} = 0, R_{gen} = 1\text{meg}, BW = 200\text{Hz}$ $f = 1\text{kHz}$

- NOTES:** 1. For design reference only, not 100% tested.
2. Pulse test duration 2ms (non-JEDEC Condition).