

# Monolithic Dual P-Channel Enhancement Mode MOSFET General Purpose Amplifier



## 3N165 / 3N166

### FEATURES

- Very High Impedance
- High Gate Breakdown
- Low Capacitance

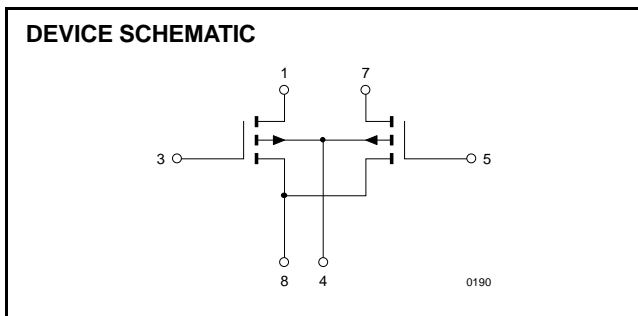
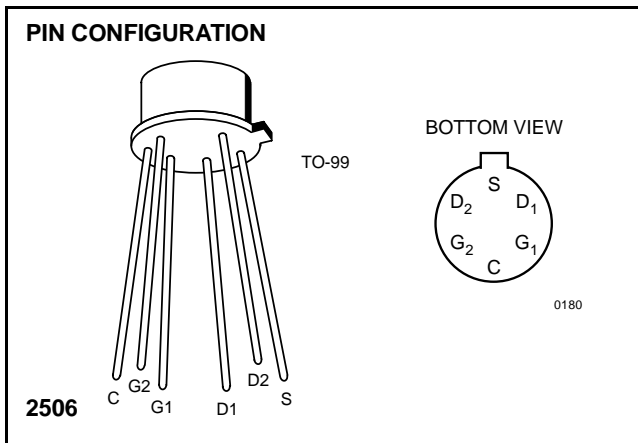

### ABSOLUTE MAXIMUM RATINGS (Note 1)

( $T_A = 25^\circ\text{C}$  unless otherwise specified)

Drain-Source or Drain-Gate Voltage (Note 2)	
3N165	40V
3N166	30V
Transient Gate-Source Voltage (Note 3)	$\pm 125$
Gate-Gate Voltage	$\pm 80\text{V}$
Drain Current (Note 2)	50mA
Storage Temperature	$-65^\circ\text{C}$ to $+200^\circ\text{C}$
Operating Temperature	$-55^\circ\text{C}$ to $+150^\circ\text{C}$
Lead Temperature (Soldering, 10sec)	$+300^\circ\text{C}$
Power Dissipation	
One Side	300mW
Both Sides	525mW
Total Derating above $25^\circ\text{C}$	4.2mW/ $^\circ\text{C}$

**NOTE:** Stresses above those listed under "Absolute Maximum Ratings" may cause permanent damage to the device. These are stress ratings only and functional operation of the device at these or any other conditions above those indicated in the operational sections of the specifications is not implied. Exposure to absolute maximum rating conditions for extended periods may affect device reliability.

### ORDERING INFORMATION

Part	Package	Temperature Range
3N165-66	Hermetic TO-99	$-55^\circ\text{C}$ to $+150^\circ\text{C}$
X3N165-66	Sorted Chips in Carriers	$-55^\circ\text{C}$ to $+150^\circ\text{C}$

### ELECTRICAL CHARACTERISTICS ( $T_A = 25^\circ\text{C}$ and $V_{BS} = 0$ unless otherwise specified)

SYMBOL	PARAMETER	MIN	MAX	UNITS	TEST CONDITIONS
$I_{GSSR}$	Gate Reverse Leakage Current		10	pA	$V_{GS} = 40\text{V}$
$I_{GSSF}$	Gate Forward Leakage Current		-10		$V_{GS} = -40\text{V}$
$I_{DSS}$	Drain to Source Leakage Current		-200		$V_{DS} = -20\text{V}$
$I_{SDS}$	Source to Drain Leakage Current		-400		$V_{SD} = -20\text{V}, V_{DB} = 0$
$I_{D(on)}$	On Drain Current	-5	-30	mA	$V_{DS} = -15\text{V}, V_{GS} = -10\text{V}$
$V_{GS(th)}$	Gate Source Threshold Voltage	-2	-5	V	$V_{DS} = -15\text{V}, I_D = -10\mu\text{A}$
$V_{GS(th)}$	Gate Source Threshold Voltage	-2	-5		$V_{DS} = V_{GS}, I_D = -10\mu\text{A}$
$r_{DS(on)}$	Drain Source ON Resistance		300	ohms	$V_{GS} = -20\text{V}, I_D = -100\mu\text{A}$

**ELECTRICAL CHARACTERISTICS** (Continued) ( $T_A = 25^{\circ}\text{C}$  and  $V_{BS} = 0$  unless otherwise specified)

SYMBOL	PARAMETER	MIN	MAX	UNITS	TEST CONDITIONS
$g_{fs}$	Forward Transconductance	1500	3000	$\mu\text{S}$	$V_{DS} = -15\text{V}$ , $I_D = -10\text{mA}$ , $f = 1\text{kHz}$
$g_{os}$	Output Admittance		300		
$C_{iss}$	Input Capacitance		3.0	$\text{pF}$	$V_{DS} = -15\text{V}$ , $I_D = -10\text{mA}$ , $f = 1\text{MHz}$ (Note 4)
$C_{riss}$	Reverse Transfer Capacitance		0.7		
$C_{oss}$	Output Capacitance		3.0		
$R_E(Y_{fs})$	Common Source Forward Transconductance	1200		$\mu\text{s}$	$V_{DS} = -15\text{V}$ , $I_D = -10\text{mA}$ , $f = 100\text{MHz}$ (Note 4)

**MATCHING CHARACTERISTICS 3N165**

SYMBOL	PARAMETER	MIN	MAX	UNITS	TEST CONDITIONS
$Y_{fs1} / Y_{fs2}$	Forward Transconductance Ratio	0.90	1.0		$V_{DS} = -15\text{V}$ , $I_D = -500\mu\text{A}$ , $f = 1\text{kHz}$
$V_{GS1-2}$	Gate Source Threshold Voltage Differential		100	$\text{mV}$	$V_{DS} = -15\text{V}$ , $I_D = -500\mu\text{A}$
$\frac{\Delta V_{GS1-2}}{\Delta T}$	Gate Source Threshold Voltage Differential Change with Temperature		100	$\mu\text{V}/^{\circ}\text{C}$	$V_{DS} = -15\text{V}$ , $I_A = -500\mu\text{A}$ $T_A = -55^{\circ}\text{C}$ to $+25^{\circ}\text{C}$

- NOTES:**
1. See handling precautions on 3N170 data sheet.
  2. Per transistor.
  3. Devices must not be tested at  $\pm 125\text{V}$  more than once, nor longer than 300ms.
  4. For design reference only, not 100% tested.