

**CLM4102 / CLM4302**

**FEATURES**

- Improved Replacement for EL2002
- Slew Rate ..... 11000V/ $\mu$ s
- Wide Bandwidth..... 400MHz
- Output Current..... 150mA
- Wide Supply Voltage.....  $\pm 3V$  to  $\pm 18V$
- Supply Current..... 5mA
- Short Circuit Product
- Low Bias Current

**APPLICATIONS**

- Op Amp Booster
- Coaxial Cable Driver
- A/D Input Buffer
- Isolation Buffer

**GENERAL DESCRIPTION**

The CLM4102 product family is a low power, wide bandwidth buffer amplifier. The 4102 family delivers a -3dB bandwidth of 400MHz, 200mA, and 11000V/ $\mu$ s while only drawing 5mA of supply current. The CLM4102 family operates over a wide supply voltage range of  $\pm 3V$  to  $\pm 18V$ .

This product is an excellent choice for coaxial cable drivers, A/D converter input buffers and fast op-amp current boosters, in applications for video, test and medical systems and military designs.

**ORDERING INFORMATION**

Part	Package	Temperature Range
CLM4102M	SOIC 20-Lead	-40°C to +85°C
CLM4102N	Plastic Dip 8-Lead	-40°C to +85°C
CLM4302M	SOIC 20-Lead	-25°C to +85°C
CLM4302N	Plastic Dip 8-Lead	-25°C to +85°C

**CONNECTION DIAGRAMS**

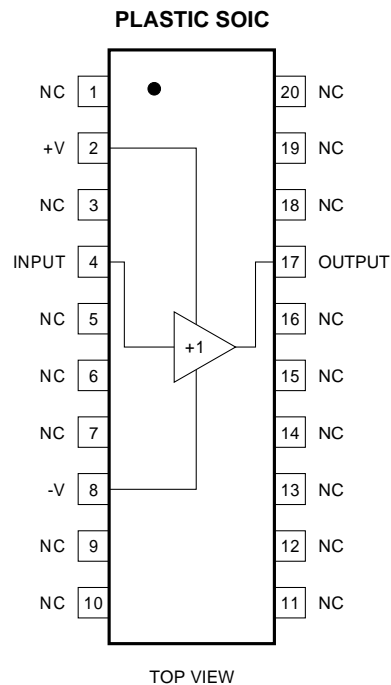
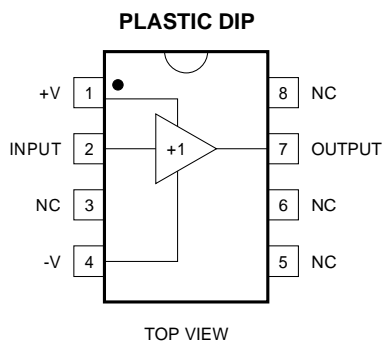

## ABSOLUTE MAXIMUM RATINGS (Note 1)

Supply Voltage .....	±20V
Input Voltage .....	±V <sub>supply</sub>
Storage Temperature Range .....	-65°C to +150°C
Lead Temperature (Soldering 10 seconds) .....	260°C
Power Dissipation .....	(Note 4)
ESD Tolerance (Note 3) .....	±2000V

Thermal Resistance ( $\theta_{JA}$ )	
N Package .....	95°C/W
M Package .....	95°C/W
Thermal Resistance ( $\theta_{JC}$ )	
N Package .....	50°C/W
M Package .....	50°C/W
Maximum Junction Temperature .....	150°C

## DC ELECTRICAL CHARACTERISTICS

The following specifications apply for Supply Voltage = ±15V,  $V_{CM} = 0$ ,  $R_L \geq 100K\Omega$  and  $R_S = 50\Omega$  unless otherwise noted. **Boldface** limits apply for  $T_A = T_J = T_{MIN}$  to  $T_{MAX}$ ; all other limits  $T_A = T_J = 25^\circ C$ .

SYMBOL	CHARACTERISTICS	TYP	CLM4102	CLM4302	UNITS	CONDITIONS
			Limit (Note 5)	Limit (Note 5)		
$A_{V1}$	Voltage Gain 1	0.99	0.96 <b>0.96</b>	0.95 <b>0.95</b>	V/V Min	$R_L = \infty, V_{IN} = \pm 12V$
$A_{V2}$	Voltage Gain 2	0.95	0.90 <b>0.90</b>	0.90 0.90		$R_L = 100\Omega, V_{IN} = \pm 10V$
$A_{V3}$	Voltage Gain 3	0.92	0.85 <b>0.85</b>	0.85 <b>0.85</b>		$R_L = 100\Omega, V_{IN} = \pm 3V, V_S = \pm 5V$
$V_{OS}$	Offset Voltage	10	15 <b>20</b>	30 <b>40</b>	mV Max	$R_L = \infty$
$I_B$	Input Bias Current	1	8 <b>10</b>	12	$\mu A$ Max	$R_L = \infty$
$R_{IN}$	Input Resistance	0.5	.2	.2	M $\Omega$	$R_L = 100\Omega$
$C_{IN}$	Input Capacitance	3.5			pF	
$R_O$	Output Resistance	3	7	10	$\Omega$ Max	$R_L = 100\Omega, V_{IN} = \pm 2V$
$I_S$	Supply Current	5	7.5	7.5	mA Max	$R_L = \infty$
$V_O$	Output Swing	10	10	10	$\pm V$ Min	$R_L = 100\Omega, V_{IN} = \pm 12V$
$I_{OUT}$	Output Current	200	100	100	mA	$V_{IN} = 12V$

**AC ELECTRICAL CHARACTERISTICS**

The following specifications apply for Supply Voltage =  $\pm 15V$ ,  $V_{CM} = 0$ ,  $R_L \geq 100K\Omega$  and  $R_S = 50\Omega$  unless otherwise noted. **Boldface** limits apply for  $T_A = T_J = T_{MIN}$  to  $T_{MAX}$ ; all other limits  $T_A = T_J = 25^\circ C$ .

SYMBOL	CHARACTERISTICS	TYP	CLM4102	CLM4302	UNITS	CONDITIONS
			Limit (Note 5)	Limit (Note 5)		
SR <sub>1</sub>	Slew Rate 1	11000	8000	6000	V/ $\mu$ s	$V_{IN} = \pm 10V$ , $R_L = 100\Omega$ (Note 2)
SS <sub>BW</sub>	Small Signal Bandwidth	400	200	200	MHz	$V_{IN} = \pm 100mV_{PP}$ , $R_L = 100\Omega$ $C_L \leq 10pF$
P <sub>BW</sub>	Power Bandwidth	100				$V_{IN} = \pm 4V$ , $R_L = 100\Omega$ $C_L \leq 10pF$
t <sub>r</sub> , t <sub>f</sub>	Rise Time Fall Time	1.2	1.7	1.7	ns	$R_L = 100\Omega$ , $C_L \leq 10pF$ $V_{IN} = 0.5V$
t <sub>pd</sub>	Propagation Delay Time	2.0			ns	$R_L = 100\Omega$ , $C_L \leq 10pF$ $V_{IN} = 0.5V$

**Note 1:** Absolute Maximum Ratings indicate limits beyond which damage to the device may occur. DC and AC electrical specifications do not apply when operating the device beyond its rated operating conditions.

**Note 2:** Slew rate is measured with  $50\Omega$  source impedance at  $25^\circ C$ . Slew rate is measured between  $V_O = +5V$  and  $-5V$ .

**Note 3:** The test circuit consists of the human body model of  $120pF$  in series with  $1500\Omega$ .

**Note 4:** The maximum power dissipation is a function of  $T_{J(max)}$ ,  $\theta_{JA}$  and  $T_A$ . The maximum allowable power dissipation at any ambient temperature is  $P_D = (T_{J(max)} - T_A)/\theta_{JA}$ .

**Note 5:** Limits are guaranteed by testing, correlation or periodic characterization.

TYPICAL PERFORMANCE CHARACTERISTICS

**SLEW RATE vs LOAD CAPACITANCE**

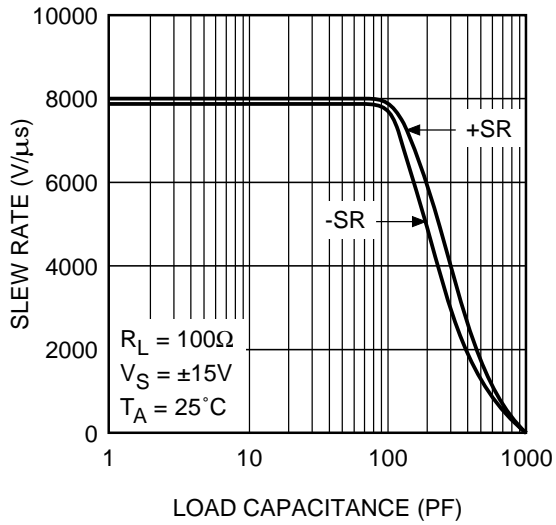

**PHASE SHIFT vs FREQUENCY FOR VARIOUS CAPACITIVE LOADS**

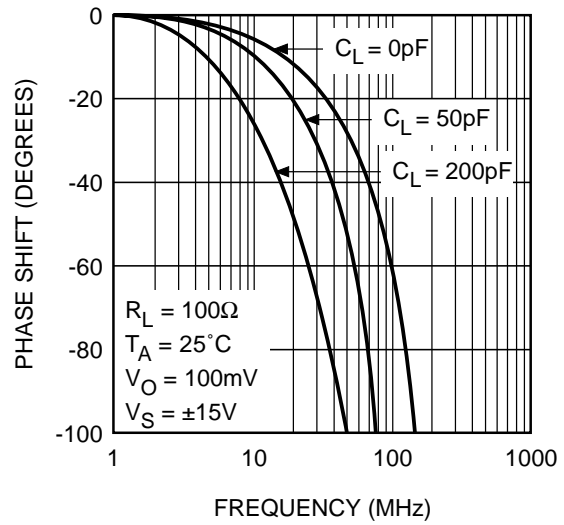

**VOLTAGE GAIN vs FREQUENCY FOR VARIOUS RESISTIVE LOADS**

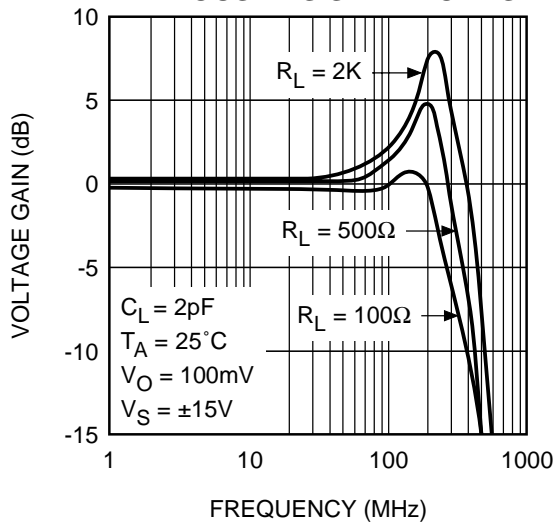

**-3dB BANDWIDTH vs SUPPLY VOLTAGE**

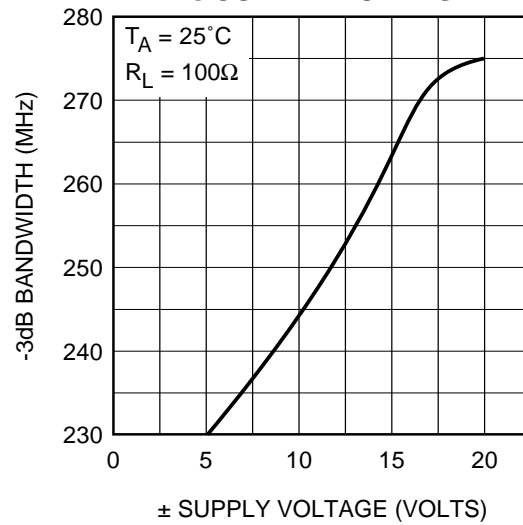

TYPICAL PERFORMANCE CHARACTERISTICS (continued)

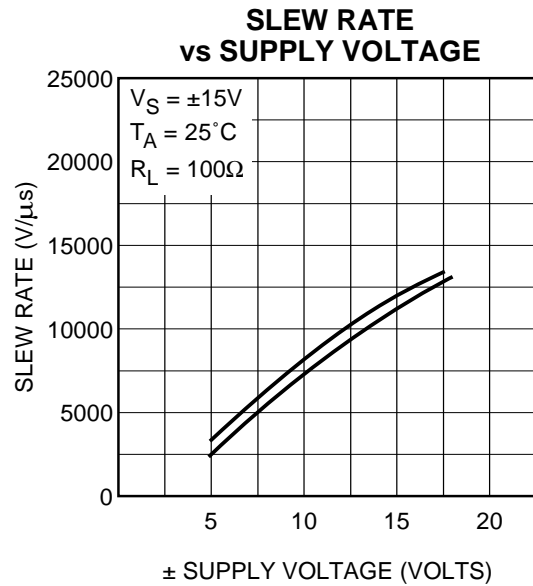
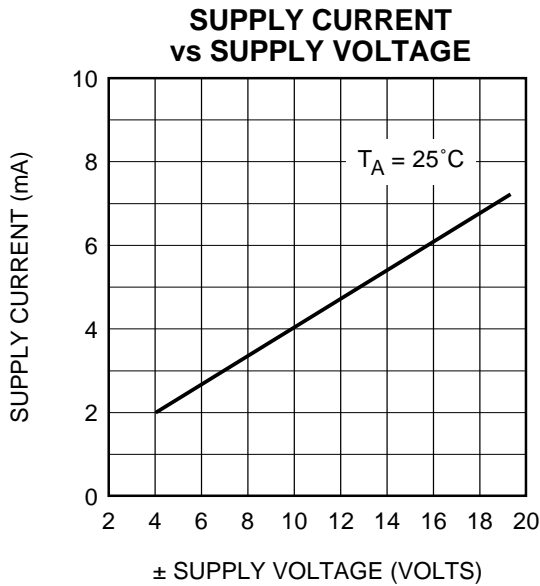

**VOLTAGE GAIN vs FREQUENCY FOR VARIOUS CAPACITIVE LOADS,  $R_L = 100\Omega$**

