

High Speed DMOS N-Channel Switch



SD403

FEATURES

- Ultra High Speed Switching $t_r < 1\text{ns}$
- Very Low Capacitance..... C_{rss} 0.4pf typical
- CMOS and TTL Compatible Input
- Low ON Resistance..... 40 ohms typical

APPLICATIONS

- Switch Drivers
- Video Switches
- Samples and Hold
- Track and Hold
- VHF/UHF Amplifiers

DESCRIPTION

The Calogic SD403 is an N-Channel Enhancement-Mode Lateral DMOS FET. This product has very low capacitance, ($C_{rss} < 0.4\text{pf}$ typical) allowing for high speed switching ($t_r < 1\text{ns}$). The SD403 is a high gain device (19mmhos) and has good performance values for sample and hold circuits, video switches and switch drivers where lower capacitance and high speed switching are critical.

ORDERING INFORMATION

Part	Package	Temperature Range
SD403BD	Plastic TO-92	-55 to +125°C
SD403CY	SOT-143 Surface Mount	-55 to +125°C
XSD403	Sorted Chips in Carriers	-55 to +125°C

PIN CONFIGURATION

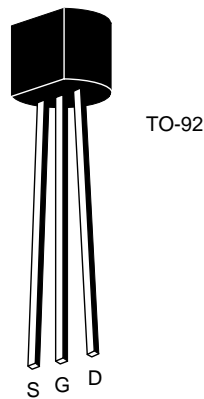

CD1-1

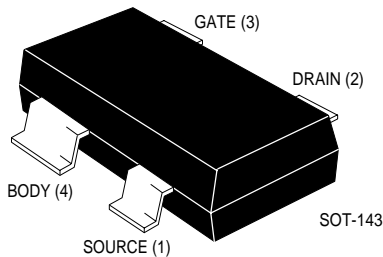

PRODUCT MARKING

SD403CY	SD403
---------	-------

SCHEMATIC DIAGRAM

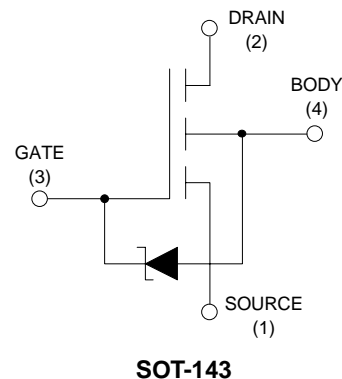
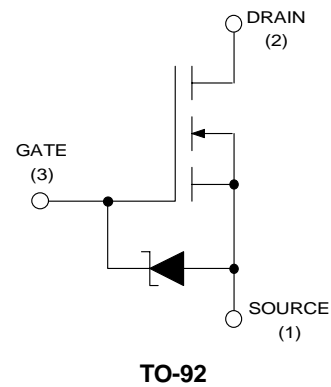

ABSOLUTE MAXIMUM RATINGS ($T_A = +25^\circ\text{C}$ unless otherwise noted)

Drain-Source Voltage	+15V	Continuous Drain Current	50mA
Gate-Source Voltage	-0.3V	Power Dissipation (at or below $T_A = +25^\circ\text{C}$)	300mW
	+20V	Linear Derating Factor	3.0mW/°C
Gate-Drain Voltage	-0.3V	Operating Junction and Storage	
	+20V	Temperature Range	-55°C to +125°C
Source-Drain Voltage	-0.3V		

ELECTRICAL CHARACTERISTICS ($T_A = +25^\circ\text{C}$ unless otherwise specified)

SYMBOL	CHARACTERISTICS	MIN	TYP	MAX	UNIT	TEST CONDITIONS
STATIC						
BV_{DSS}	Drain-Source Breakdown Voltage	15	25		V	$I_D = 1.0\mu\text{A}$, $V_{GS} = 0$
$I_{D(OFF)}$	Drain-Source OFF Leakage Current			1.0	μA	$V_{DS} = 15\text{V}$, $V_{GS} = 0$
I_{GSS}	Gate-Source Leakage Current			1.0	μA	$V_{GS} = 20\text{V}$, $V_{DS} = 0$
$I_{D(ON)}$	Drain-Source ON Current	80	120		mA	$V_{DS} = 10\text{V}$, $V_{GS} = 10\text{V}$ Pulse Test
$V_{GS(th)}$	Gate-Source Threshold Voltage	0.3		1.5	V	$I_D = 1.0\mu\text{A}$, $V_{DS} = V_{GS}$
$V_{DS(ON)}$	Drain-Source ON Voltage		140	175	mV	$I_D = 1\text{mA}$, $V_{GS} = 2.4\text{V}$
$r_{DS(ON)}$	Drain-Source ON Resistance		140	175	ohms	
$V_{DS(ON)}$	Drain-Source ON Voltage		40	60	mV	$I_D = 1\text{mA}$, $V_{GS} = 4.5\text{V}$
$r_{DS(ON)}$	Drain-Source ON Resistance		40	60	ohms	
DYNAMIC						
g_{fs}	Common-Source Forward Transconductance	15	19		mS	$I_D = 20\text{mA}$, $V_{DS} = 10\text{V}$, $f = 1\text{KHz}$ Pulse Test
C_{iss}	Common-Source Input Capacitance		4.5	6.0	pf	$V_{DS} = 10\text{V}$, $V_{GS} = 0$ $f = 1\text{MHz}$
C_{oss}	Common-Source Output Capacitance		2.0	3.0		
C_{rss}	Common-Source Reverse Transfer Capacitance		0.4	0.6		
$t_{d(on)}$	Turn ON Delay Time		0.8	1.2	ns	$V_{DD} = 10\text{V}$, $R_L = 680\Omega$ $V_{G(ON)} = 10\text{V}$, $R_G = 51\Omega$ $C_L = 1.5\text{pF}$
t_r	Rise Time		0.9	1.2		
$t_{(OFF)}$	Turn OFF Time		1.4			

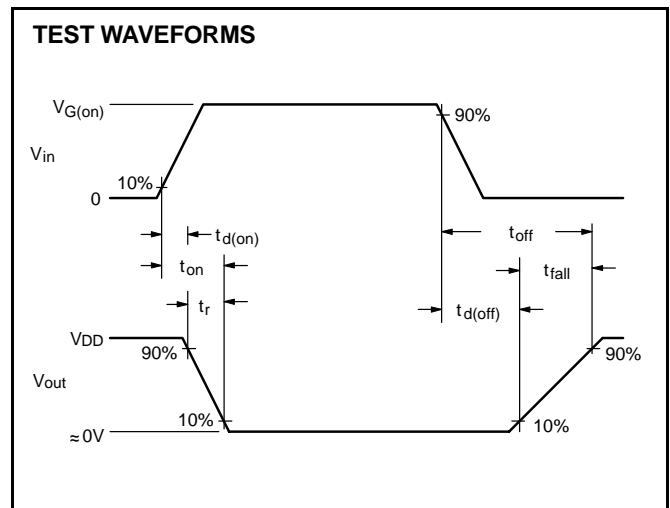
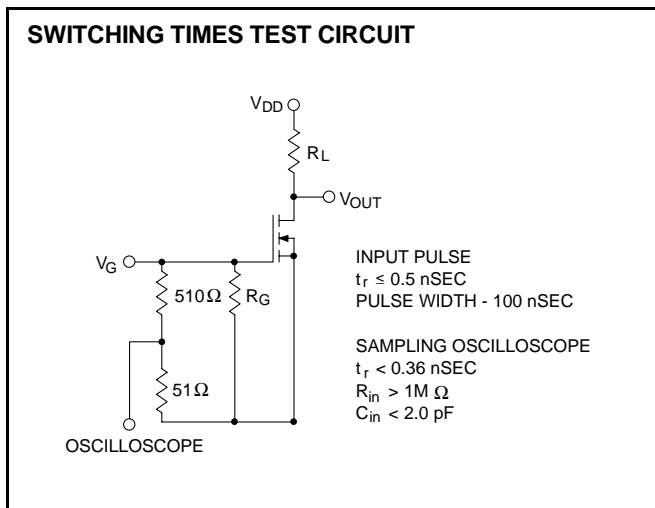

TYPICAL PERFORMANCE CHARACTERISTICS ($T_A = +25^\circ\text{C}$ unless otherwise noted)

