

400 WATT AC/DC POWER SUPPLY

PX401/403

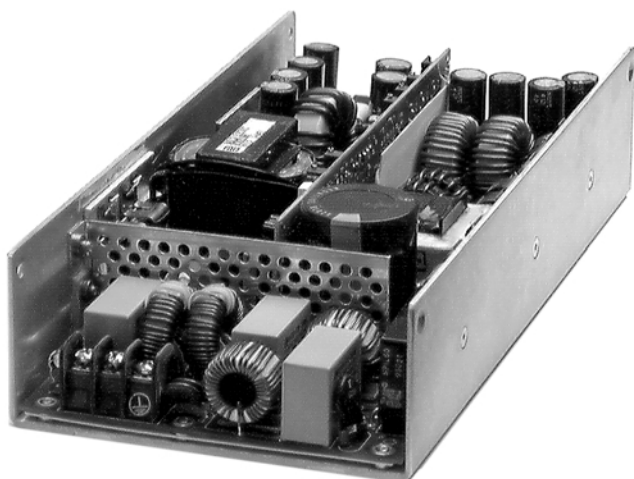

DESCRIPTION

The PX401 is a compact 400 watt Power Factor Corrected, multiple output power supply. All outputs are fully isolated and regulated. Active current sharing circuitry, together with control functions and alarm options, simplifies N+1 and redundant applications. Fan and disk drive applications are handled by the peak current ratings of the auxiliary outputs.

FEATURES

- Active Power Factor Correction
- High Surge Current Auxiliary Outputs
- FCC/VDE Class B EMI Filter
- Fully Isolated and Regulated Outputs
- Compact Size: 10" x 4.85" x 2.19"
- One, Two, Three and Four Output Models
- Optional Cover With Fan

AGENCY APPROVALS



JV Rheinland

Internet: <http://www.cdpowerelectronics.com>

Power Electronics Division, United States
3400 E Britannia Drive, Tucson, Arizona 85706
Phone: 800.547.2537 Fax: 520.770.9369

Power Electronics Division, Europe
C&D Technologies (Power Electronics) Ltd.
132 Shannon Industrial Estate, Shannon, Co. Clare, Ireland
Tel: +353.61.474.133 Fax: +353.61.474.141

Input Specifications

Parameter	Conditions	Min	Typ	Max	Units
Operating Range	47-63 Hz	90		264	VAC
Inrush Current Limiting	120 VAC, cold start			30	APK
	240 VAC, cold start			60	APK
Efficiency	Nominal line and full load		75		%
Power Factor Correction (PFC)	Meets IEC 1000-4-7/EN61000-3-2 (formerly IEC 555-2)			0.99	

Remote Sense

Remote Sense is provided on Output #1 and will compensate for 1.0V of line drop. Remote Sense leads are protected against open, short and reversal.

Remote On/Off

The power supply is turned on with a TTL logic '1' (or open) signal and turned off by a switch closure or TTL logic '0' referenced to (-) sense terminal. Consult the factory for other options.

Over Voltage Protection

Output #1: 6.5V, $\pm 0.5 V_{DC}$

The power supply will latch off until AC power is cycled.

Over Current Protection

Individual current limit on all outputs. Automatic recovery upon fault removal.

Transient Response

The peak output voltage excursion will not exceed 2% and will recover within 1% in 200 μ sec for a 25% step load.

Output Isolation

All outputs are fully isolated.

Reverse Voltage Protection

All outputs are protected to rated load current.

Power Fail Signal

Upon AC input voltage removal, the power fail signal drops to logic zero at least 10msec before loss of DC output. Upon AC input turn-on, signal remains low until outputs are in regulation. Consult the factory for other options.

N+1 Load Share (PX403)

Output #1 has active load sharing circuitry. Units will load share within 1% of Maximum Rated Load.

Over Temperature Protection

Thermal switch turns off power supply if overheating occurs and automatically restarts.

Safety

UL Recognized: UL File Number E14675 (1950 & 1012)

CSA Certified: CSA File Number LR 9070-154C
(C22.2 No9. 234-M90, Level 6)

TUV License Number: R9576029 (EN60950) (IEC950)

Cooling

The unit is designed to operate with 40 CFM airflow.

Output Voltages and Maximum Rated Loads

MODEL NUMBER	OUTPUT #1		OUTPUT #2		OUTPUT #3		OUTPUT #4	
	V _{OUT}	I _{MAX}	V _{NOM}	I _{MAX} /I _{PK}	V _{NOM}	I _{MAX} /I _{PK}	V _{NOM}	I _{MAX}
PX401/403-U3A	± 5V	50A	± 12V	12A/14A	± 12V	12A/14A	-	-
PX401/403-U3B	± 5V	50A	± 15V	12A/14A	± 15V	12A/14A	-	-
PX401/403-U4C	± 5V	50A	± 12V	10A/12A	± 12V	10A/12A	± 5V	3.0A
PX401/403-U4D	± 5V	50A	± 12V	10A/12A	± 12V	10A/12A	± 24V	2.0A
PX401/403-U4E	± 5V	50A	± 12V	10A/12A	± 12V	10A/12A	± 12V	3.0A
PX401/403-U4F	± 5V	50A	± 15V	10A/12A	± 15V	10A/12A	± 5V	3.0A
PX401/403-U4G	± 5V	50A	± 15V	10A/12A	± 15V	10A/12A	± 24V	2.0A
PX401/403-U4H	± 5V	50A	± 12V	10A/12A	± 12V	10A/12A	± 5.2V	10.0A
PX401/403-U4I	± 5V	50A	± 15V	10A	± 15V	10A	± 5.2V	10.0A
PX401/403-U4J	± 5V	20A	± 17V	3A	± 17V	3A	± 24V	10.0A
PX401/403-U4K	± 5V	25A	± 12V	10A	± 12V	10A	± 12V	4.0A
PX401/403-U4L	± 5V	30A	± 12V	10A	± 12V	10A	± 5.2V	3.0A
PX401/403-U4M	± 5V	30A	± 15V	12A	± 15V	12A	± 5.2V	10.0A
PX401/403-U4N	± 5V	70A	± 12V	12A	± 12V	12A	± 3.3V	10.0A
PX401/403-U4P	± 5V	30A	± 12V	10A	± 12V	12A	± 24V	3.0A
PX401/403-U4R	± 5V	20A	± 15V	4A	± 15V	4A	± 24V	10.0A
PX401/403-U4S	± 5V	20A	± 12V	8A	± 12V	3A	± 24V	10.0A

Note: Peak current ratings are for 10sec maximum. Total power not to exceed 400 watts.

Output Specifications

Parameter	Limits
Regulation	
Line	± 0.1%
Load	±0.5%
Cross	±0.1%
Minimum Load	
Output #1	2.5A
Hold-Up Time	30mSec at Full Load

Parameter	Conditions	Min	Typ	Max	Units
Voltage Adjustment Range			±5		%
PARD	20 MHz bandwidth		0.5		% P-P
Temperature					
Operating		0		50	°C
Storage		-20		+85	°C
Temperature Coefficient (Tc)	After half hour warm-up		± 0.02		%/°C

Mechanical

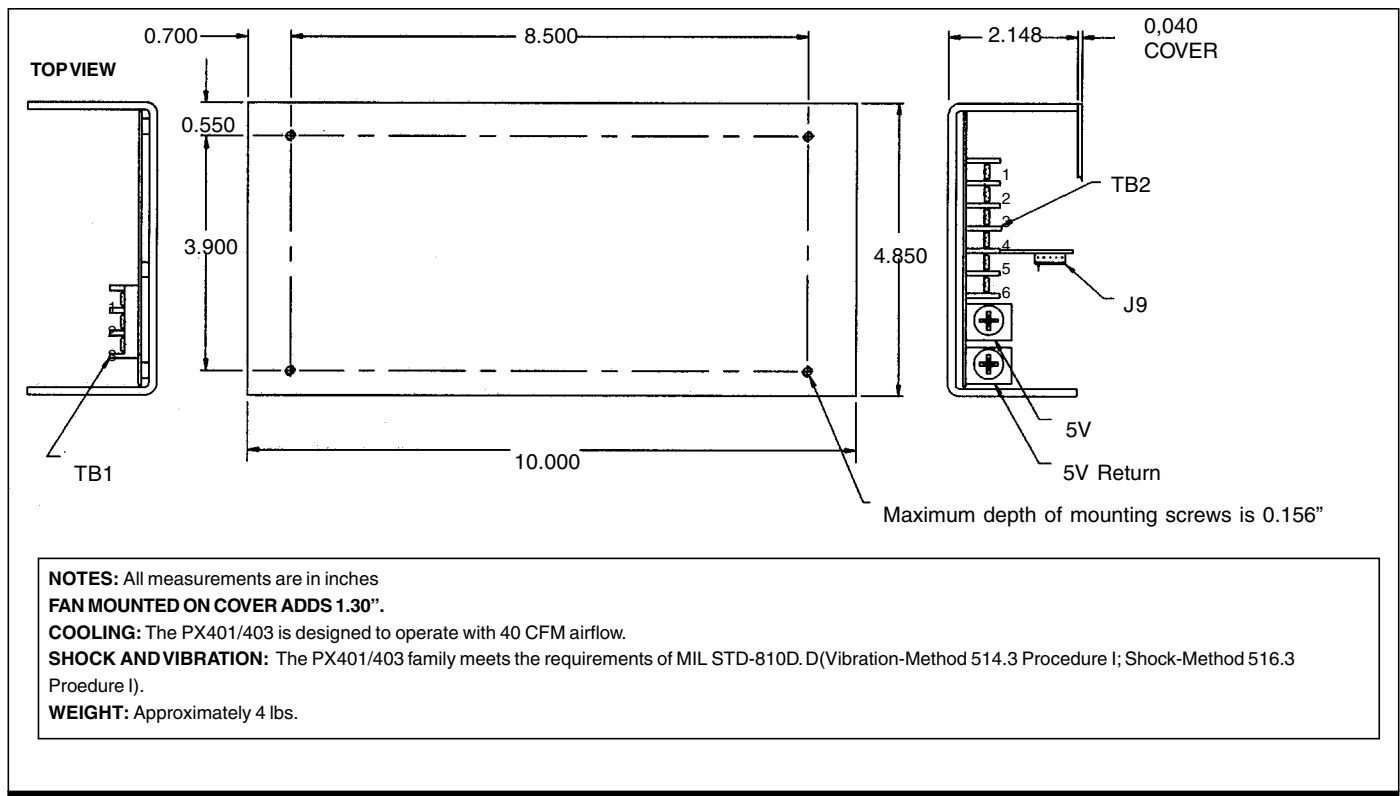

Pin Specifications

Terminal Block 1		Terminal Block 2	
POS	FUNCTION	POS	FUNCTION
1	Ground	1	-V4
2	AC Neutral	2	+V4
3	AC Line	3	-V3
		4	+V3
		5	-V2
		6	+V2

Connector Specifications

J9 Connector		J9 Connector	
PIN	FUNCTION		Molex No.
1	- Sense	Connector	22-28-1050
2	+ Sense		
3	Current Share		
4	Remote Inhibit		
5	Power Fail		

Model PX403 features Active Current Sharing

Standard Options are shown, consult factory for other available options.

The information provided herein is believed to be reliable; however, C&D Technologies assumes no responsibility for inaccuracies or omissions. C&D Technologies assumes no responsibility for the use of this information, and all use of such information shall be entirely at the user's own risk. Prices and specifications are subject to change without notice. No patent rights or licenses to any of the circuits described herein are implied or granted to any third party. C&D Technologies does not authorize or warrant any C&D