



Advanced Product Information  
May 1999 (1 of 4)

# 824 to 928 MHz 3.0V, 30.5 dBm Multi-Mode Plastic LCC-8 Power Amplifier

### Features

- ❑ Multi-Mode Operation as Low as 3.0V
- ❑ 42% Linear Power Added Efficiency
- ❑ 55% Analog Power Added Efficiency
- ❑ New Low-Cost, Plastic LCC-8 Package
- ❑ 29 dB Gain
- ❑ Tested Under Digital Modulation
- ❑ PHEMT Material Technology

### Applications

- ❑ IS-98/AMPS Handsets
- ❑ IS-136/AMPS Cellular Handsets
- ❑ 900 MHz ISM Band Products
- ❑ Wireless Local Loop Subscriber Terminals

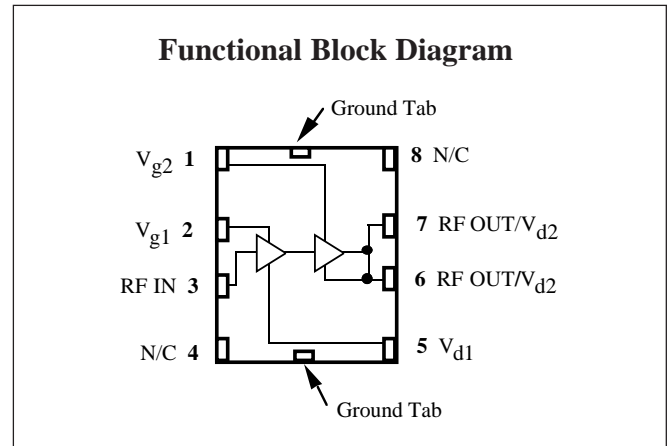

### Description

The CMM0530-LC is a highly efficient multi-mode power amplifier GaAs MMIC intended for use in portable telephone handsets and data communications products for wireless communications. It meets the handset requirements for cellular AMPS, and the CDMA and TDMA digital standards for the US cellular wireless communications. CMM0530-LC is a member

of the new *Triniti DX Pro™* amplifier family whose members are pin-compatible and all operate under 3.5V bias voltage. The CMM0530-LC is packaged in a low-cost, plastic, LCC-8 power package. It has low thermal impedance and low RF loss. The device requires minimum amount of external biasing and RF matching circuits.

### Absolute Maximum Ratings

Parameter	Rating	Parameter	Rating	Parameter	Rating
Drain Voltage (+V <sub>d</sub> )	+5.5 V*	Power Dissipation	5 W	Operating Temperature	-40°C to +90°C
Drain Current (I <sub>d</sub> )	1.8 A	Thermal Resistance	20°C/W	Channel Temperature	150°C
RF Input Power	+10 dBm*	Storage Temperature	-65°C to +150°C	Soldering Temperature	260°C for 5 Sec.
DC Gate Voltage (-V <sub>g</sub> )	-3.0 V*				

\* Max (+V<sub>d</sub>) and (-V<sub>g</sub>) under linear operation. Max potential difference across the device at 1 dB gain compression point (2V<sub>d</sub> + |-V<sub>g</sub>|) not to exceed the minimum breakdown voltage (V<sub>br</sub>) of +12V.

### Recommended Operating Conditions

Parameter	Typ	Units	Parameter	Typ	Units
Drain Voltage (+V <sub>d</sub> )	3.0 to 4.2	Volts	Operating Temperature (PC Board)	-30 to +80	°C

### Application Information

The CMM0530-LC is a two-stage amplifier that requires both positive and negative power supplies for proper operation. It is essential that the negative supply be applied first during turn-on and last during turn-off. Otherwise, the device may be damaged.

The CMM0530-LC can be operated over a wide range of positive and negative voltages to obtain various power, linearity and efficiency performance. However, it is important to keep the maximum DC power and the bias voltages within the specified absolute maximum rating to prevent over stressing the device either electrically or thermally.

### Design Considerations

**Biasing** Negative gate voltages are necessary to set the bias currents of the two FET stages in the CMM0530-LC. The first stage gate bias voltage is applied to Vg1 (Pin 2). The second stage gate bias voltage is applied to Vg2 (Pin 1). It is desirable to use one or more DACs (digital to analog converters) along

with appropriate resistor divider networks, when necessary, in order to adjust the quiescent currents to within 10 mA of the targeted values. As an example, for CDMA applications the targeted quiescent current of the second FET is 120 mA, while that of the first is 50 mA. The total quiescent is 170 mA. It is also recommend that the quiescent currents be set in the following sequence: the second stage FET is set first, followed by the first stage FET. The negative supply voltages control the quiescent currents through each FET and, therefore, control the output power, adjacent channel power ratio, and the currents at full output power.

The positive supply voltages are applied to Pins 5, 6 and 7.

It is very important to provide adequate de-coupling between the RF and the DC signals in designing the DC bias circuit. Inadequate by-pass capacitance around the DC supply lines and inductance can compromise the adjacent channel power ratio (ACPR), or reduce power gain and/or create oscillations. The recommend DC by-pass capacitance and low-pass

- Continued on Page 2 -

## Electrical Characteristics

Unless otherwise specified, the following specifications are guaranteed at room temperature with drain voltage (+V<sub>d</sub>) = 3.5 V, in Celeritek test fixture.

Parameter	Condition	Digital Bias			Analog Bias			Units
		Min	Typ	Max	Min	Typ	Max	
Frequency Range		824		928	824		928	MHz
Pout - TDMA Operation	Meets IS-136 TDMA mask		+30.0					dBm
Pout - CDMA Operation	Meets IS-98 CDMA mask		+28.5					dBm
Pout - Analog Operation	AMPS (under dual mode operation)					+31.5		dBm
Efficiency	IS-136 TDMA @ +30 dBm		42					%
	IS-95 CDMA @ +28 dBm		37					%
	AMPS @ +31.5 dBm (under dual mode operation)				55	57		%
Harmonics	2nd @ Pout = +31.5 dBm					-30		dBc
	3rd @ Pout = +31.5 dBm					-35		dBc
Adjacent Channel Power	Pout = +30 dBm TDMA ±30 KHz	-26						dBc
Alternate Channel Power	Pout = +30 dBm TDMA ±60 KHz	-45						dBc
Adjacent Channel Power	Pout = +28 dBm CDMA ±898 KHz	-45						dBc/30 KHz
Alternate Channel Power	Pout = +28 dBm CDMA ±1980 KHz	-55						dBc/30 KHz
Noise Power in Receive Band	30 kHz BW		-94					dBm
Gain	@ Pout = +28.5 dBm, +30 dBm	26	29					dB
	@ Pout = +31.5 dBm				24	27		dB
Gain Ripple	824-849 or 880-910 MHz			1.5			1.5	dB
Gain Variation	Over supply voltage		2			2		dB/V
Gain Variation	Over temperature		0.03			0.03		dB/°C
Power Output Control Range	Vdd = 0 to 3.5 V		50					dB
Quiescent Current	No RF, TDMA mode		200					mA
	No RF, CDMA mode		170					mA
Noise Figure			3.5			3.5		dB
VSWR	Input (In Celeritek test fixture)		2.0:1			2.0:1		
Stability	8:1 VSWR in band			-80			-80	dBc/30 KHz
	10:1 VSWR out of band			-80			-80	dBc/30 KHz

- Continued from Page 1 -

in-line inductance are shown in the evaluation board on page 4.

**Matching Circuits** Output matching and input matching circuits are required to achieve the RF specifications in this data sheet. The recommend matching circuits are identical to the matching circuits for the evaluation board shown on Page 4. For output power matching, shunt capacitors along the transmission line connected to Pins 6 and 7 as well as the bond wire inside the package from the output leads to the output FET are used to transform 50Ω impedance to the load line resistance of the output FET. The placements and the values of the capacitor are important in achieving the performance desired. Matching circuits for frequencies other than the one shown can be achieved by changing the capacitor value and the placement position of the capacitor. The device can be designed to work from UHF to around 3 GHz.

**Supply Ramping** To obtain power ramping, gate supply control is recommended. Drain supply voltage can also be used.

**Modulation** When biased as specified, the CMM0530-LC will achieve the required adjacent channel response for the digital system specified. Celeritek tests each product under digital modulation to ensure correlation to customer applications.

## Thermal

1. The copper pad on the backside of the CMM0530-LC must be soldered to the ground plane.
2. All 8 leads of the package must be soldered to the appropriate electrical connection.

## Typical Performance

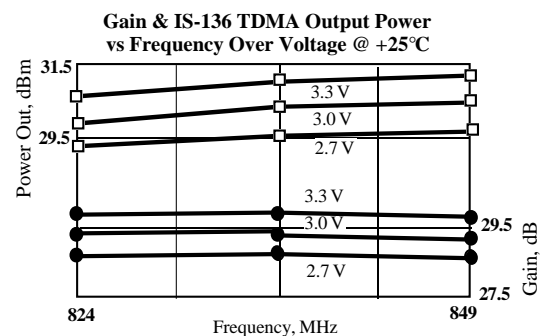

## Typical Performance

IS-136 TDMA Spectral Mask (Vdd = 3.5V)

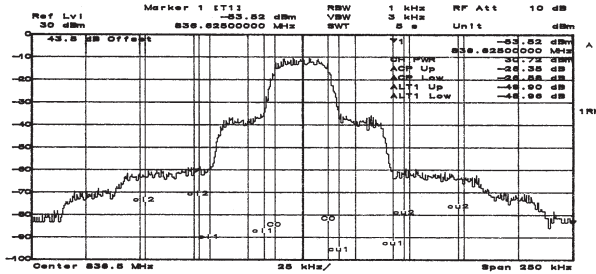

IS-98 CDMA Spectral Mask (Vdd = 3.5V)

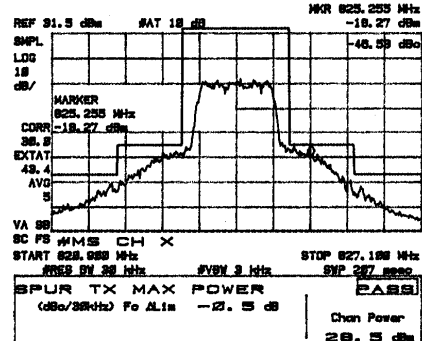

Id & IS-136 TDMA Channel Power vs Power Output (3.5V, 836.5 MHz)

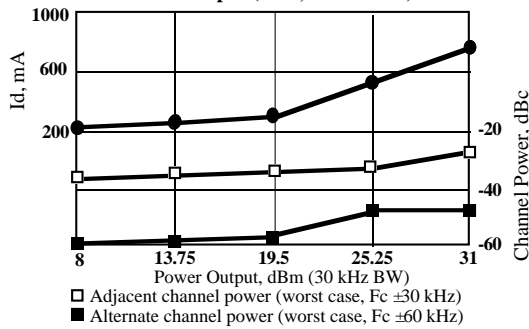

Id & IS-98 CDMA Channel Power vs Power Output (3.5V, 836.5 MHz)

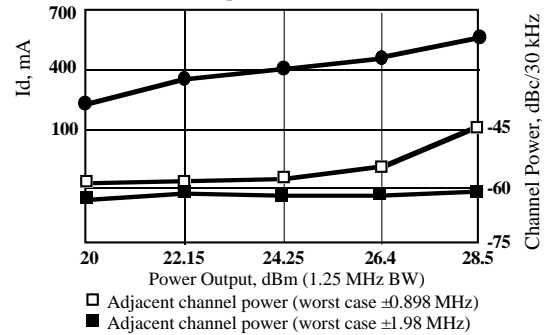

TDMA Power Output and Efficiency vs Input Power (3.5V, 836.5 MHz)

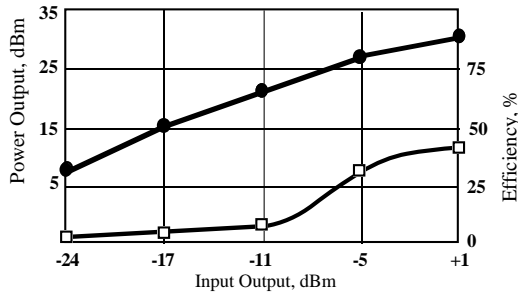

CDMA Power Output and Efficiency vs Input Power (3.5V, 836.5 MHz)

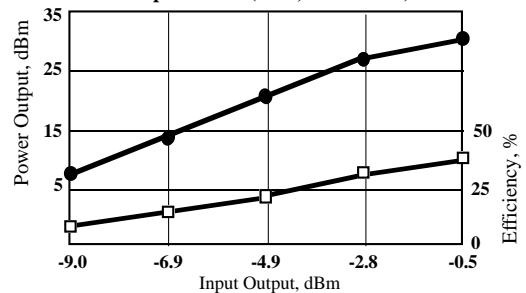

Wideband Gain & Return Loss vs Frequency @ 3.5V, +25°C

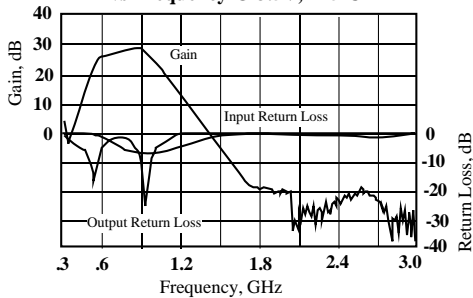

## Recommended Matching Topology

Note: This schematic represents the topology of the matching circuit recommended by Celeritek.

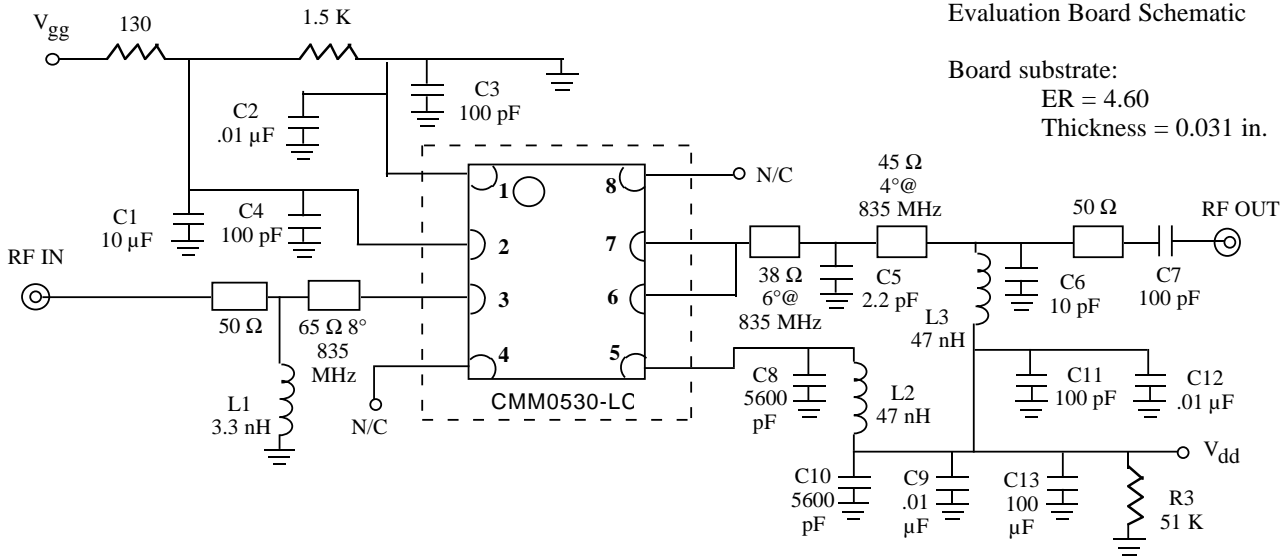

## Physical Dimensions

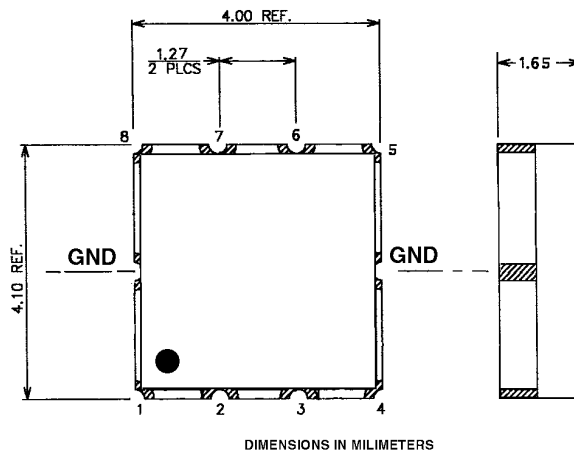

## Ordering Information

The CMM0530-LC is available in a surface mount wide-body MSOP-8 power package and devices are available in tape and reel.

### Part Number for Ordering

**CMM0530-LC-00S0**

**CMM0530-LC-00T0**

**CMM0530-LC-00ST**

**CMM0530-LC-00TT**

**PB-CMM0530-LC-00S0**

**PB-CMM0530-LC-00T0**

### Package

**LCC-8 CDMA surface mount power package**

**LCC-8 TDMA surface mount power package**

**LCC-8 CDMA surface mount power package in tape and reel**

**LCC-8 TDMA surface mount power package in tape and reel**

**Evaluation Board with SMA connectors for CMM0530-LC-00S0**

**Evaluation Board with SMA connectors for CMM0530-LC-00T0**

Celeritek reserves the right to make changes without further notice to any products herein. Celeritek makes no warranty, representation or guarantee regarding the suitability of its products for any particular purpose, nor does Celeritek assume any liability arising out of the application or use of any product or circuit, and specifically disclaims any and all liability, including without limitation consequential or incidental damages. "Typical" parameters can and do vary in different applications. All operating parameters, including "Typicals" must be validated for each customer application by customer's technical experts. Celeritek does not convey any license under its patent rights nor the rights of others. Celeritek products are not designed, intended, or authorized for use as components in systems intended for surgical implant into the body, or other applications intended to support or sustain life, or for any other application in which the failure of the Celeritek product could create a situation where personal injury or death may occur. Should Buyer purchase or use Celeritek products for any such unintended or unauthorized application, Buyer shall indemnify and hold Celeritek and its officers, employees, subsidiaries, affiliates, and distributors harmless against all claims, costs, damages, and expenses, and reasonable attorney fees arising out of, directly or indirectly, any claim of personal injury or death associated with such unintended or unauthorized use, even if such claim alleges that Celeritek was negligent regarding the design or manufacture of the part. Celeritek is a registered trademark of Celeritek, Inc. Celeritek, Inc. is an Equal Opportunity/Affirmative Action Employer.