

CZR1-04C
SURFACE MOUNT
HIGH VOLTAGE RECTIFIER



SOT-223 CASE

CentralTM

Semiconductor Corp.

DESCRIPTION:

The CENTRAL SEMICONDUCTOR CZR1-04C type is a Silicon General Purpose Dual Rectifier, connected in a Common Cathode configuration, designed for applications requiring high voltage capability.

<u>MAXIMUM RATINGS</u> (T _A =25°C)	<u>SYMBOL</u>	<u>UNITS</u>
Reverse Voltage	V _R	400 V
Peak Reverse Voltage	V _{RM}	400 V
Average Forward Current	I _O	2.0 A
Peak Forward Surge Current, t=1.0μs	I _{FSM}	10 A
Operating and Storage		
Junction Temperature	T _J , T _{stg}	-65 to +150 °C
Power Dissipation	P _D	2.0 W
Thermal Resistance	θ _{JA}	62.5 °C/W

ELECTRICAL CHARACTERISTICS PER DIODE: (T_A=25°C unless otherwise noted)

<u>SYMBOL</u>	<u>TEST CONDITIONS</u>	<u>MAX</u>	<u>TYP</u>	<u>MAX</u>	<u>UNITS</u>
I _R	V _R =400V			1.0	μA
I _R	V _R =400V, T _A =150°C			50	μA
BV _R	I _R =100μA	400			V
V _F	I _F =1.0A			1.6	V
V _F	I _F =2.0A			2.0	V
t _{rr}	I _F =200mA, I _R =200mA, I _{RR} =20mA		1.0		μs
C _J	V _R =0V, f=1.0MHz		10		pF

**SURFACE MOUNT
HIGH VOLTAGE RECTIFIER**

MECHANICAL OUTLINE - SOT-223

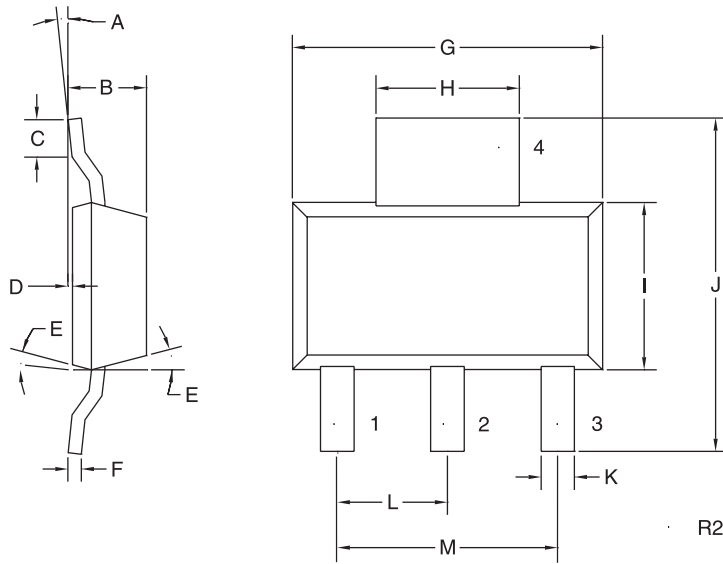

LEAD CODE:

- 1. ANODE 1
- 2. CATHODE
- 3. ANODE 2
- 4. CATHODE

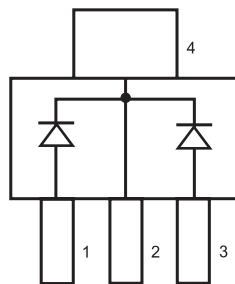

SYMBOL	INCHES		MILLIMETERS	
	MIN	MAX	MIN	MAX
A	0°	7°	0°	7°
B	0.063	0.067	1.60	1.70
C	0.022		0.55	
D	0.001	0.004	0.03	0.10
E	15°		15°	
F	0.009	0.013	0.23	0.33
G	0.248	0.264	6.30	6.71
H	0.114	0.122	2.90	3.10
I	0.130	0.146	3.30	3.71
J	0.264	0.287	6.71	7.29
K	0.024	0.031	0.61	0.79
L	0.091		2.31	
M	0.181		4.60	

SOT-223 (REV: R2)