



# Low Voltage Precision Air-Core Tach/Speedo Driver

## Description

The CS4121 is specifically designed for use with air-core meter movements. The IC provides all the functions necessary for an analog tachometer or speedometer. The CS4121 takes a speed sensor input and generates sine and cosine related output signals to differentially drive an air-core meter.

Many enhancements have been added over industry standard tachometer drivers such as the CS289 or LM1819. The output utilizes differential drivers which elim-

inates the need for a zener reference and offers more torque. The device withstands 60V transients which decreases the protection circuitry required. The device is also more precise than existing devices allowing for fewer trims and for use in a speedometer.

The CS4121 is compatible with the CS8190, and provides higher accuracy at a lower supply voltage (8.0V min. as opposed to 8.5V). It is functionally operational to 6.5V.

## Absolute Maximum Ratings

Supply Voltage (<100ms pulse transient).....	V <sub>CC</sub> = 60V
(continuous) .....	V <sub>CC</sub> = 24V
Operating Temperature .....	-40°C to +105°C
Storage Temperature .....	-40°C to +165°C
Junction Temperature .....	-40°C to +150°C
ESD (Human Body Model) .....	4kV
Lead Temperature Soldering	
Wave Solder (through hole styles only).....	10 sec. max, 260°C peak
Reflow (SMD styles only).....	60 sec. max above 183°C, 230°C peak

## Block Diagram

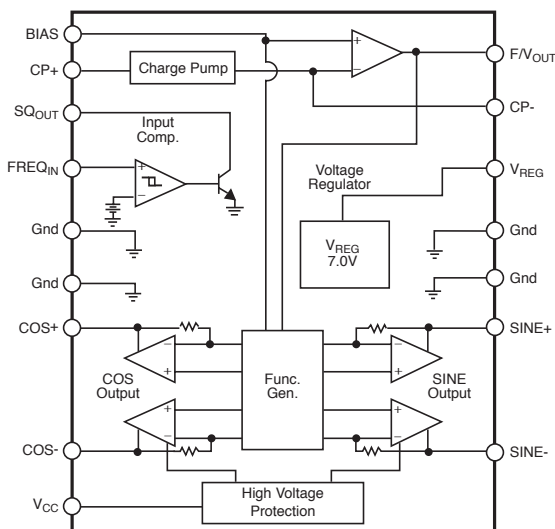

## Features

- Direct Sensor Input
- High Torque Output
- Low Pointer Flutter
- High Input Impedance
- Overvoltage Protection
- Accurate to 8V Functional to 6.5V (typ)

## Package Options

16 Lead PDIP (internally fused leads)

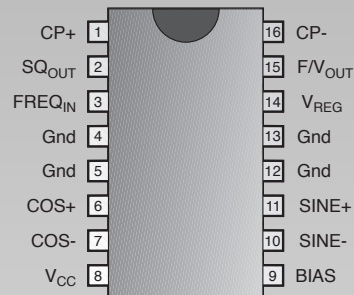

20 Lead SOIC (internally fused leads)

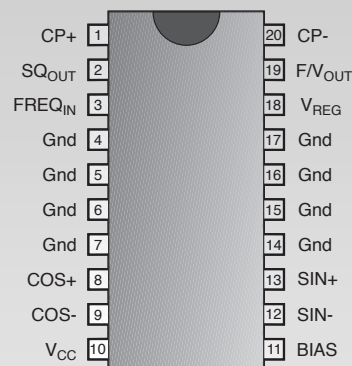

Cherry Semiconductor Corporation  
 2000 South County Trail, East Greenwich, RI 02818  
 Tel: (401)885-3600 Fax: (401)885-5786  
 Email: info@cherry-semi.com  
 Web Site: www.cherry-semi.com

**Electrical Characteristics:  $-40^{\circ}\text{C} \leq T_A \leq 85^{\circ}\text{C}$ ,  $8.0\text{V} \leq V_{CC} \leq 16\text{V}$  unless otherwise specified.**

PARAMETER	TEST CONDITIONS	MIN	TYP	MAX	UNIT
<b>■ Supply Voltage Section</b>					
$I_{CC}$ Supply Current	$V_{CC} = 16\text{V}$ , $-40^{\circ}\text{C}$ , No Load		50	125	mA
$V_{CC}$ Normal Operation Range		8.0	13.1	16.0	V

**■ Input Comparator Section**

Positive Input Threshold		1.0	2.0	3.0	V
Input Hysteresis		200	500		mV
Input Bias Current *	$0\text{V} \leq V_{IN} \leq 8\text{V}$		-10	-80	$\mu\text{A}$
Input Frequency Range		0		20	kHz
Input Voltage Range	in series with $1\text{k}\Omega$	-1		$V_{CC}$	V
Output $V_{SAT}$	$I_{CC} = 10\text{mA}$		0.15	0.40	V
Output Leakage	$V_{CC} = 7\text{V}$			10	$\mu\text{A}$
Logic 0 Input Voltage		1			V

\*Note: Input is clamped by an internal 12V Zener.

**■ Voltage Regulator Section**

Output Voltage		6.25	7.00	7.50	V
Output Load Current				10	mA
Output Load Regulation	0 to 10 mA		10	50	mV
Output Line Regulation	$8.0\text{V} \leq V_{CC} \leq 16\text{V}$		20	150	mV
Power Supply Rejection	$V_{CC} = 13.1\text{V}$ , $1V_P/P$ 1kHz	34	46		dB

**■ Charge Pump Section**

Inverting Input Voltage		1.5	2.0	2.5	V
Input Bias Current			40	150	nA
Vbias Input Voltage		1.5	2.0	2.5	V
Non Invert. Input Voltage	$I_{IN} = 1\text{mA}$		0.7	1.1	V
Linearity*	@ 0, 87.5, 175, 262.5, + 350Hz	-0.10	0.28	+0.70	%
F/ $V_{OUT}$ Gain	@ 350Hz, $C_T = 0.0033\mu\text{F}$ , $R_T = 243\text{k}\Omega$	7	10	13	mV/Hz
Norton Gain, Positive	$I_{IN} = 15\mu\text{A}$	0.9	1.0	1.1	I/I
Norton Gain, Negative	$I_{IN} = 15\mu\text{A}$	0.9	1.0	1.1	I/I

\*Note: Applies to % of full scale (270°).

**■ Function Generator Section:  $-40^{\circ}\text{C} \leq T_A \leq 85^{\circ}\text{C}$ ,  $V_{CC} = 13.1\text{V}$  unless otherwise noted.**

Differential Drive Voltage ( $V_{COS+} - V_{COS-}$ )	$8.0\text{V} \leq V_{CC} \leq 16\text{V}$ $\Theta = 0^{\circ}$	5.5	6.5	7.5	V
Differential Drive Voltage ( $V_{SIN+} - V_{SIN-}$ )	$8.0\text{V} \leq V_{CC} \leq 16\text{V}$ $\Theta = 90^{\circ}$	5.5	6.5	7.5	V
Differential Drive Voltage ( $V_{COS+} - V_{COS-}$ )	$8.0\text{V} \leq V_{CC} \leq 16\text{V}$ $\Theta = 180^{\circ}$	-7.5	-6.5	-5.5	V
Differential Drive Voltage ( $V_{SIN+} - V_{SIN-}$ )	$8.0\text{V} \leq V_{CC} \leq 16\text{V}$ $\Theta = 270^{\circ}$	-7.5	-6.5	-5.5	V
Differential Drive Current	$8.0\text{V} \leq V_{CC} \leq 16\text{V}$ , $T_A = 25^{\circ}\text{C}$		33	42	mA
Zero Hertz Output Angle		-1.5	0.0	1.5	deg
Function Generator Error *	$V_{CC} = 13.1\text{V}$ , $T_A = 25^{\circ}\text{C}$ Reference Figures 1,2,3,4 $\Theta = 0^{\circ}$ to $305^{\circ}$	-2	0	+2	deg

\*Note: Deviation from nominal per Table 1 after calibration at  $0^{\circ}$  and  $270^{\circ}$ .

## Electrical Characteristics: continued

PARAMETER	TEST CONDITIONS	MIN	TYP	MAX	UNIT
<b>Function Generator Section: continued</b>					
Function Generator Error	$13.1V \leq V_{CC} \leq 16V, T_A=25^\circ C$	-2.5	0	+2.5	deg
Function Generator Error	$13.1V \leq V_{CC} \leq 11V, T_A=25^\circ C$	-1	0	+1	deg
Function Generator Error	$13.1V \leq V_{CC} \leq 8V, T_A=25^\circ C$	-3	0	+3	deg
Function Generator Error	$25^\circ C \leq T_A \leq 85^\circ C$	-3	0	+3	deg
Function Generator Error	$25^\circ C \leq T_A \leq 105^\circ C$	-5.5	0	+5.5	deg
Function Generator Error	$-40^\circ C \leq T_A \leq 25^\circ C$	-3	0	+3	deg
Function Generator Gain	$T_A = 25^\circ C \Theta$ vs $F/V_{OUT}$	60	77	95	$^\circ/V$

## Package Lead Description

PACKAGE LEAD #		LEAD SYMBOL	FUNCTION
16L PDIP*	20L SO*		
1	1	CP+	Positive input to charge pump.
2	2	SQ <sub>OUT</sub>	Buffered square wave output signal.
3	3	FREQ <sub>IN</sub>	Speed or rpm input signal.
4, 5, 12, 13	4-7, 14-17	Gnd	Ground Connections.
6	8	COS+	Positive cosine output signal.
7	9	COS-	Negative cosine output signal.
8	10	V <sub>CC</sub>	Ignition or battery supply voltage.
9	11	BIAS	Test point or zero adjustment.
10	12	SIN-	Negative sine output signal.
11	13	SIN+	Positive sine output signal.
14	18	V <sub>REG</sub>	Voltage regulator output.
15	19	F/V <sub>OUT</sub>	Output voltage proportional to input signal frequency.
16	20	CP-	Negative input to charge pump.

\*Internally Fused Leads

## Typical Performance Characteristics

Figure 1: Function Generator Output Voltage vs Degrees of Deflection

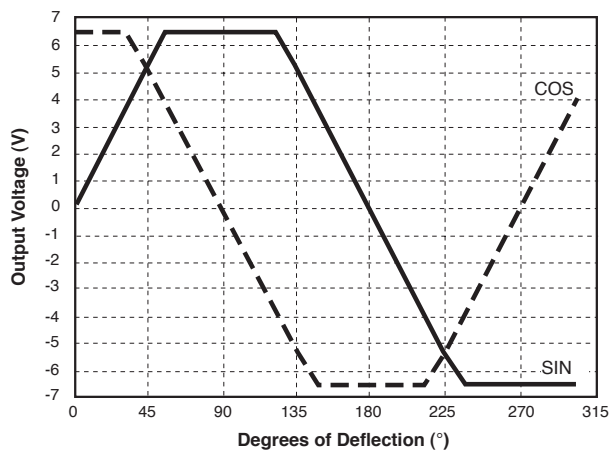
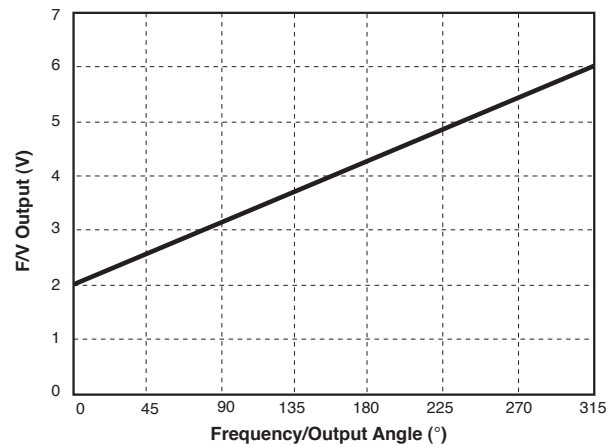

Figure 2: Charge Pump Output Voltage vs Output Angle

$$F/V_{OUT} = 2.0V + 2 \text{ FREQ} \times C_T \times R_T \times (V_{REG} - 0.7)$$



Typical Performance Characteristics: continued

Figure 3: Output Angle in Polar Form

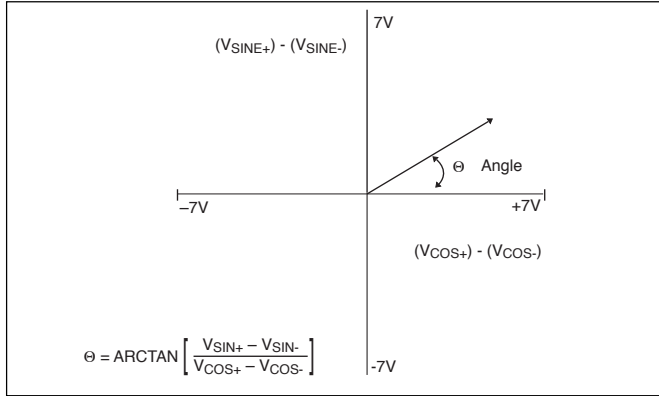
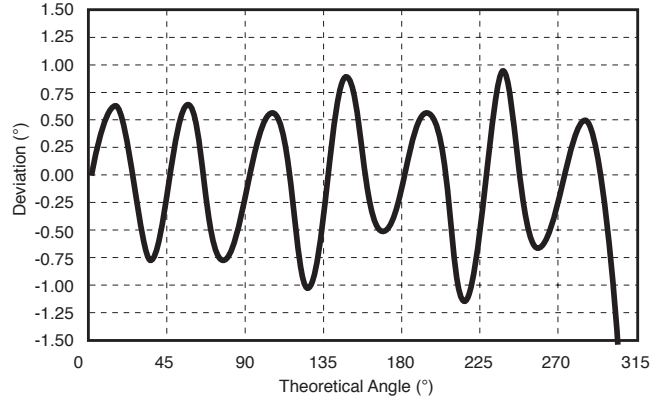

Figure 4: Nominal Output Deviation



Nominal Angle vs. Ideal Angle (After calibrating at 180°)

Note: Temperature, voltage and nonlinearity not included.

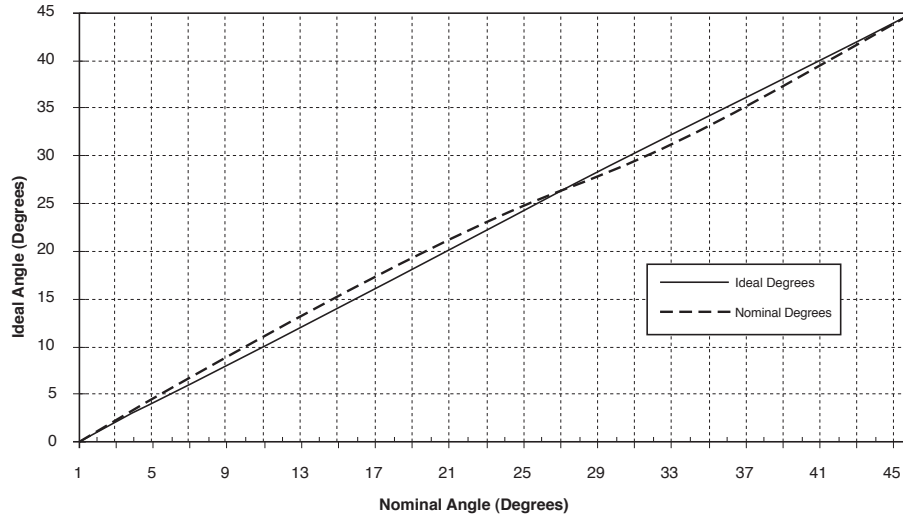

Table 1: Function Generator Output Nominal Angle vs. Ideal Angle (After calibrating at 270°)

Ideal $\theta$ Degrees	Nominal $\theta$ Degrees	Ideal $\theta$ Degrees	Nominal $\theta$ Degrees	Ideal $\theta$ Degrees	Nominal $\theta$ Degrees	Ideal $\theta$ Degrees	Nominal $\theta$ Degrees	Ideal $\theta$ Degrees	Nominal $\theta$ Degrees	Ideal $\theta$ Degrees	Nominal $\theta$ Degrees
0	0	17	17.98	34	33.04	75	74.00	160	159.14	245	244.63
1	1.09	18	18.96	35	34.00	80	79.16	165	164.00	250	249.14
2	2.19	19	19.92	36	35.00	85	84.53	170	169.16	255	254.00
3	3.29	20	20.86	37	36.04	90	90.00	175	174.33	260	259.16
4	4.38	21	21.79	38	37.11	95	95.47	180	180.00	265	264.53
5	5.47	22	22.71	39	38.21	100	100.84	185	185.47	270	270.00
6	6.56	23	23.61	40	39.32	105	106.00	190	190.84	275	275.47
7	7.64	24	24.50	41	40.45	110	110.86	195	196.00	280	280.84
8	8.72	25	25.37	42	41.59	115	115.37	200	200.86	285	286.00
9	9.78	26	26.23	43	42.73	120	119.56	205	205.37	290	290.86
10	10.84	27	27.07	44	43.88	125	124.00	210	209.56	295	295.37
11	11.90	28	27.79	45	45.00	130	129.32	215	214.00	300	299.21
12	12.94	29	28.73	50	50.68	135	135.00	220	219.32	305	303.02
13	13.97	30	29.56	55	56.00	140	140.68	225	225.00		
14	14.99	31	30.39	60	60.44	145	146.00	230	230.58		
15	16.00	32	31.24	65	64.63	150	150.44	235	236.00		
16	17.00	33	32.12	70	69.14	155	154.63	240	240.44		

Note: Temperature, voltage and nonlinearity not included.

The CS4121 is specifically designed for use with air-core meter movements. It includes an input comparator for sensing an input signal from an ignition pulse or speed sensor, a charge pump for frequency to voltage conversion, a bandgap voltage regulator for stable operation, and a function generator with sine and cosine amplifiers to differentially drive the motor coils.

From the simplified block diagram of Figure 5A, the input signal is applied to the  $FREQ_{IN}$  lead, this is the input to a high impedance comparator with a typical positive input threshold of 2.0V and typical hysteresis of 0.5V. The output of the comparator,  $SQ_{OUT}$ , is applied to the charge pump input CP+ through an external capacitor  $C_T$ . When the input signal changes state,  $C_T$  is charged or discharged through R3 and R4. The charge accumulated on  $C_T$  is mirrored to C4 by the Norton Amplifier circuit comprising of Q1, Q2 and Q3. The charge pump output voltage,  $F/V_{OUT}$ , ranges from 2V to 6.3V depending on the input signal frequency and the gain of the charge pump according to the formula:

$$F/V_{OUT} = 2.0V + 2 \times FREQ \times C_T \times R_T \times (V_{REG} - 0.7V)$$

$R_T$  is a potentiometer used to adjust the gain of the  $F/V$  output stage and give the correct meter deflection. The  $F/V$  output voltage is applied to the function generator which generates the sine and cosine output voltages. The output voltage of the sine and cosine amplifiers are derived from the on-chip amplifier and function generator circuitry. The various trip points for the circuit (i.e., 0°, 90°, 180°, 270°) are determined by an internal resistor divider and the bandgap voltage reference. The coils are differentially driven, allowing bidirectional current flow in the outputs, thus providing up to 305° range of meter deflection. Driving the coils differentially offers faster response time, higher current capability, higher output voltage swings, and reduced external component count. The key advantage is a higher torque output for the pointer.

The output angle,  $\Theta$ , is equal to the  $F/V$  gain multiplied by the function generator gain:

$$\Theta = A_{F/V} \times A_{FG}$$

where:

$$A_{FG} = 77^\circ/V \text{ (typ)}$$

The relationship between input frequency and output angle is:

$$\Theta = A_{FG} \times 2 \times FREQ \times C_T \times R_T \times (V_{REG} - 0.7V)$$

$$\text{or, } \Theta = 970 \times FREQ \times C_T \times R_T$$

The ripple voltage at the  $F/V$  converter's output is determined by the ratio of  $C_T$  and C4 in the formula:

$$\Delta V = \frac{C_T(V_{REG} - 0.7V)}{C4}$$

Ripple voltage on the  $F/V$  output causes pointer or needle flutter especially at low input frequencies.

The response time of the  $F/V$  is determined by the time constant formed by  $R_T$  and C4. Increasing the value of C4 will reduce the ripple on the  $F/V$  output but will also increase the response time. An increase in response time causes a very slow meter movement and may be unacceptable for many applications.

## Design Example

Maximum meter Deflection = 270°

Maximum Input Frequency = 350Hz

### 1. Select $R_T$ and $C_T$

$$\Theta = A_{GEN} \times \Delta_{F/V}$$

$$\Delta_{F/V} = 2 \times FREQ \times C_T \times R_T \times (V_{REG} - 0.7V)$$

$$\Theta = 970 \times FREQ \times C_T \times R_T$$

Let  $C_T = 0.0033\mu F$ , Find  $R_T$

$$R_T = \frac{270^\circ}{970 \times 350\text{Hz} \times 0.0033\mu F}$$

$$R_T = 243\text{k}\Omega$$

$R_T$  should be a 250k $\Omega$  potentiometer to trim out any inaccuracies due to IC tolerances or meter movement pointer placement.

### 2. Select R3 and R4

Resistor R3 sets the output current from the voltage regulator. The maximum output current from the voltage regulator is 10mA R3 must ensure that the current does not exceed this limit.

Choose R3 = 3.3k $\Omega$

The charge current for  $C_T$  is

$$\frac{V_{REG} - 0.7V}{3.3\text{k}\Omega} = 1.90\text{mA}$$

C1 must charge and discharge fully during each cycle of the input signal. Time for one cycle at maximum frequency is 2.85ms. To ensure that  $C_T$  is discharged, assume that the (R3 + R4)  $C_T$  time constant is less than 10% of the minimum input frequency pulse width.

$$T = 285\mu s$$

Choose R4 = 1k $\Omega$ .

Charge time:  $T = R3 \times C_T = 3.3\text{k}\Omega \times 0.0033\mu F = 10.9\mu s$

Discharge time:  $T = (R3 + R4)C_T = 4.3\text{k}\Omega \times 0.0033\mu F = 14.2\mu s$

### 3. Determine C4

C4 is selected to satisfy both the maximum allowable ripple voltage and response time of the meter movement.

$$C4 = \frac{C_T(V_{REG} - 0.7V)}{V_{RIPPLE(MAX)}}$$

With C4 = 0.47 $\mu F$ , the  $F/V$  ripple voltage is 44mV.

Figure 7 shows how the CS4121 and the CS-8441 are used to produce a Speedometer and Odometer circuit.

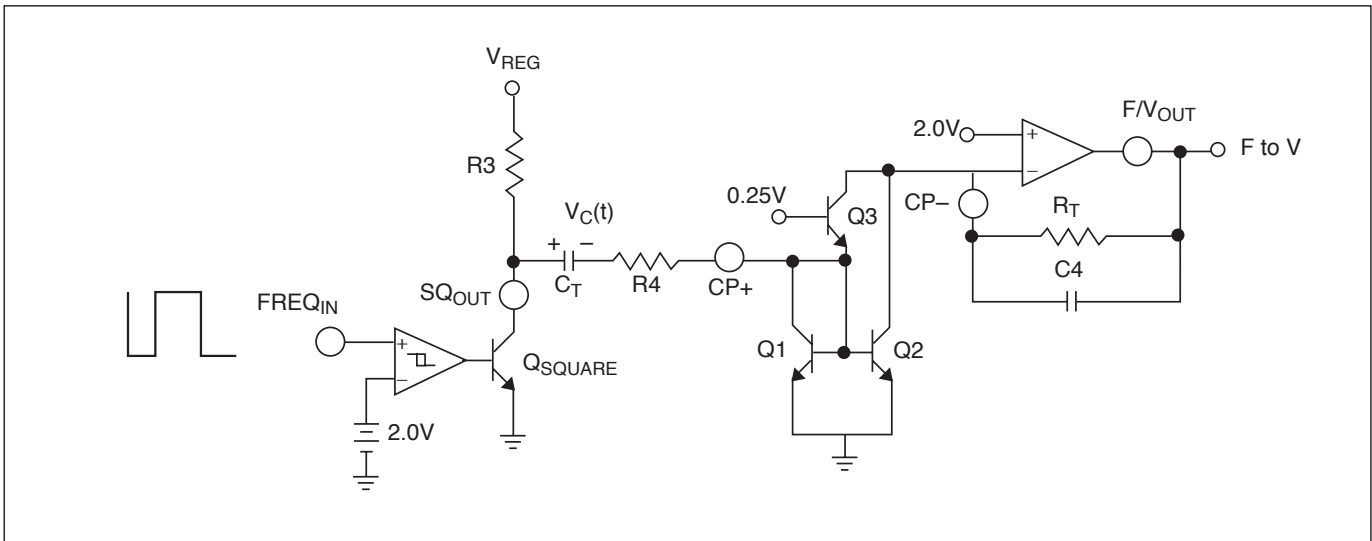

Figure 5A: Partial Schematic of Input and Charge Pump

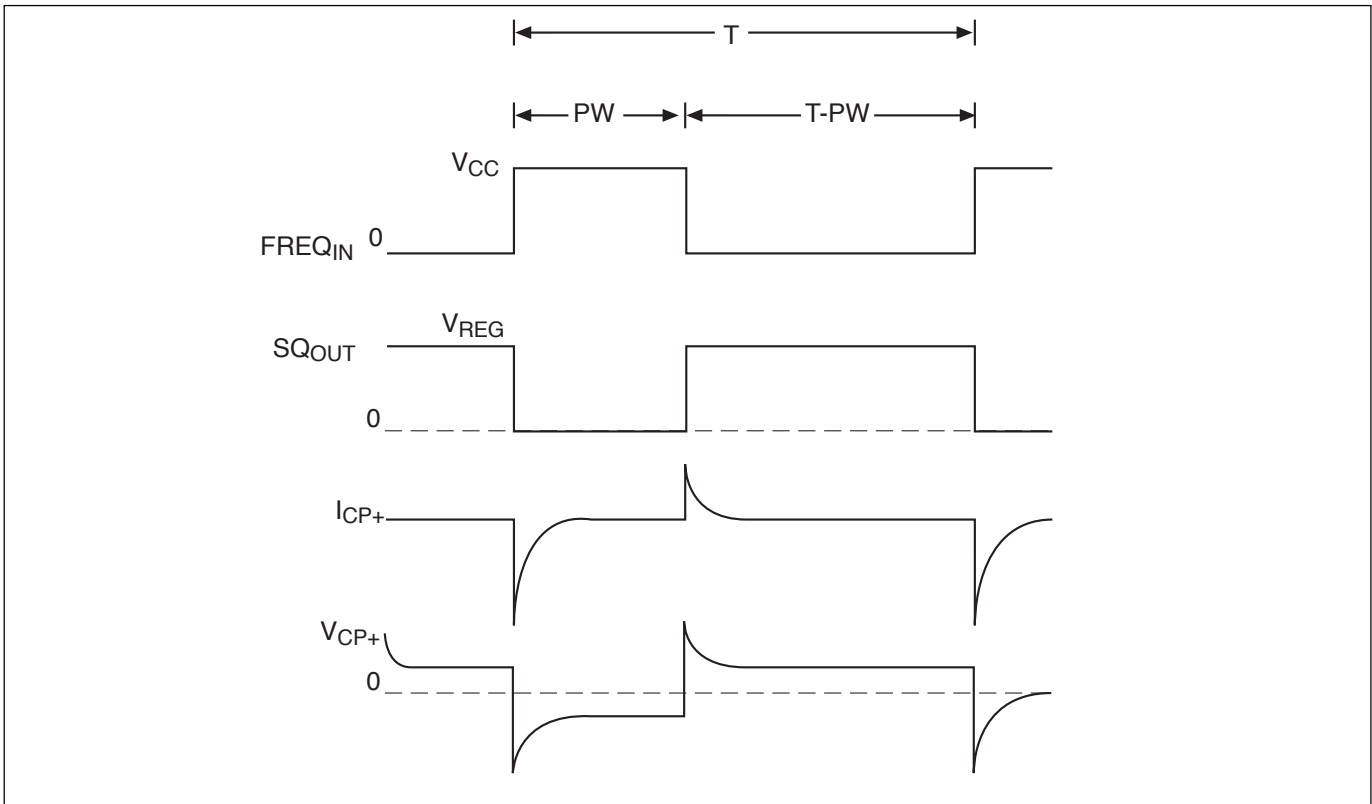

Figure 5B: Timing Diagram of  $FREQ_{IN}$  and  $I_{CP}$

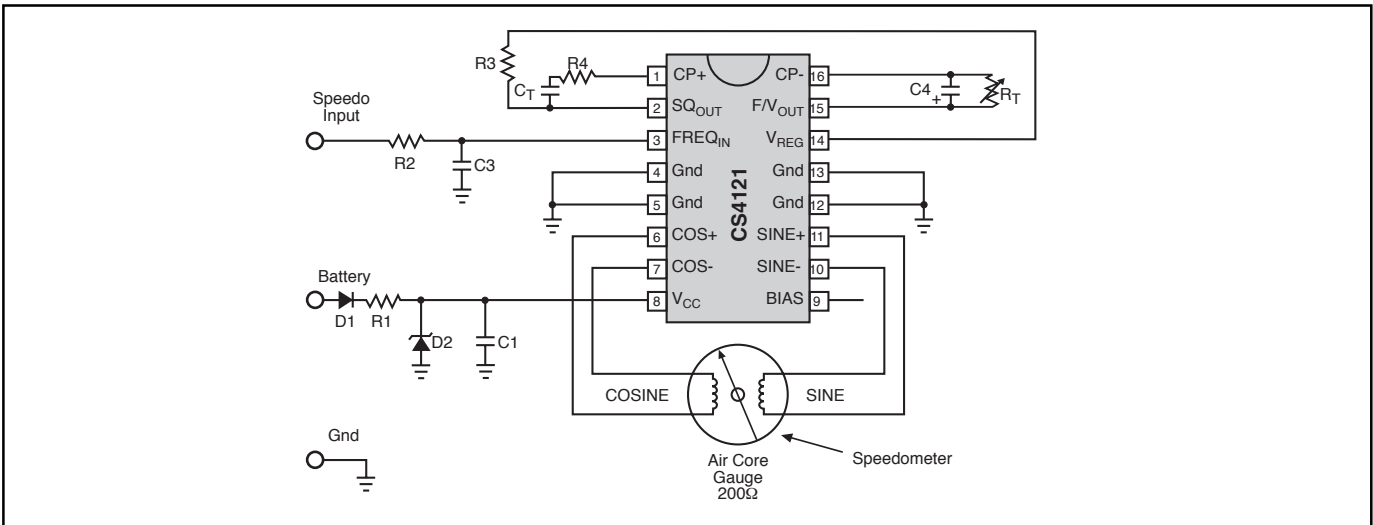

Figure 6

- R1 - 3.9, 500mW
- R2 - 10kΩ
- R3 - 3kΩ
- R4 - 1kΩ
- R<sub>T</sub> - Trim Resistor +/- 20 PPM/°C 243kΩ
- C1 - 0.1μF
- C3 - 0.1μF
- C4 - 0.47μF

C<sub>T</sub> - 0.0033μF, +/- 30 PPM/°C

D1 - 1A, 600 PIV

D2 - 50V, 500mW Zener

Note 1: For 58% Speed Input  $T_{MAX} \leq 5/f_{MAX}$  where

$$T_{MAX} = C_T(R_3+R_4)$$

f<sub>MAX</sub> = maximum speed input frequency

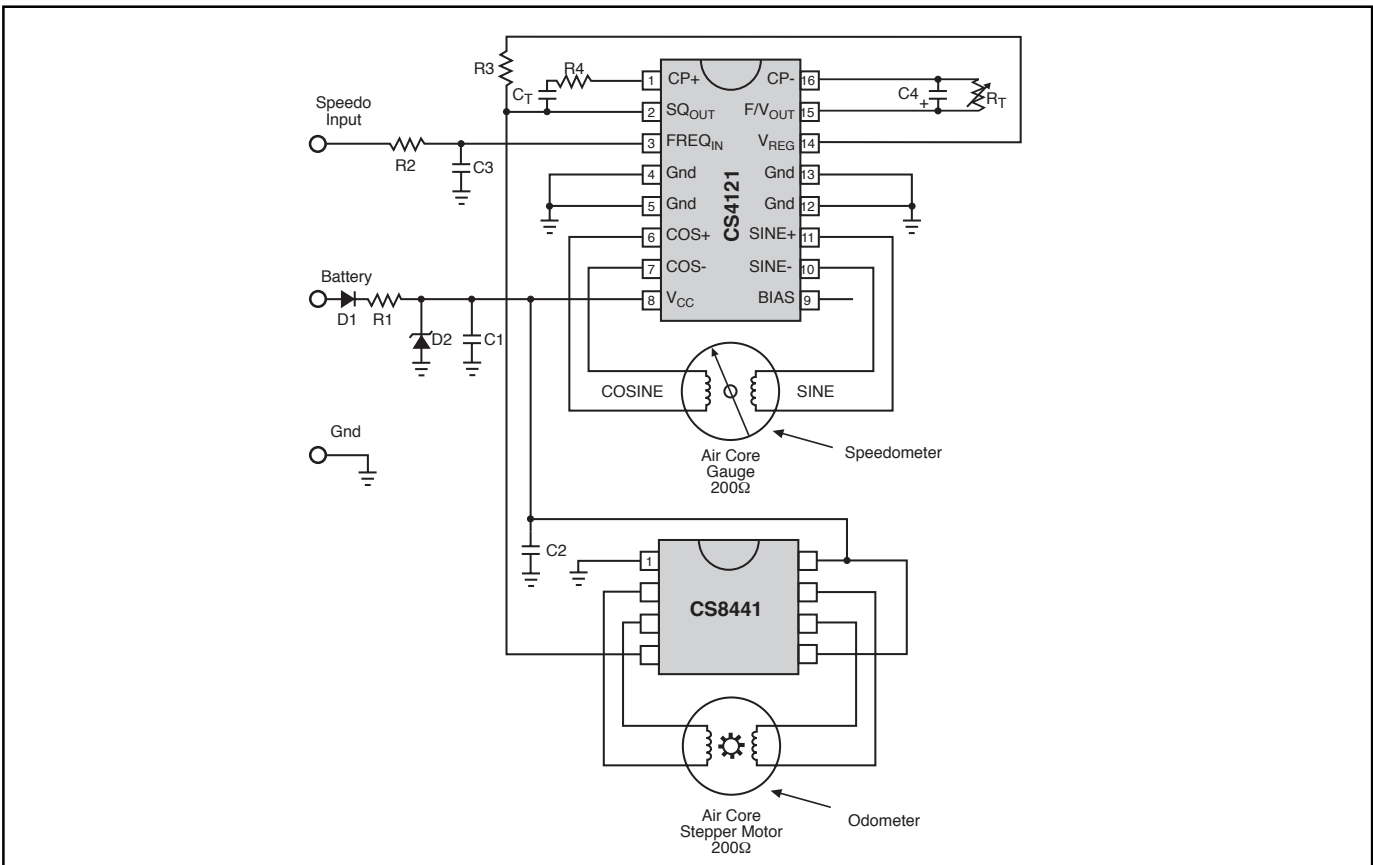

Figure 7

Note 1: The product of C<sub>T</sub> and R<sub>T</sub> have a direct effect on gain and therefore directly affect temperature compensation

Note 2: C<sub>T</sub> Range; 20pF to .2μF

Note 3: R<sub>T</sub> Range; 100kΩ to 500kΩ

Note 4: The IC must be protected from transients above 60V and reverse battery conditions

Note 5: Additional filtering on FREQ<sub>IN</sub> lead may be required

**Package Specification**

**PACKAGE DIMENSIONS IN mm (INCHES)**

Lead Count	D			
	Metric		English	
	Max	Min	Max	Min
16L PDIP*	19.69	18.67	.775	.735
20L SOIC*	13.00	12.60	.512	.496

**PACKAGE THERMAL DATA**

Thermal Data		16L PDIP*	20L SOIC*	
R <sub>θJC</sub>	typ	15	9	°C/W
R <sub>θJA</sub>	typ	50	55	°C/W

\*Internally Fused Leads

**Plastic DIP (N); 300 mil wide**

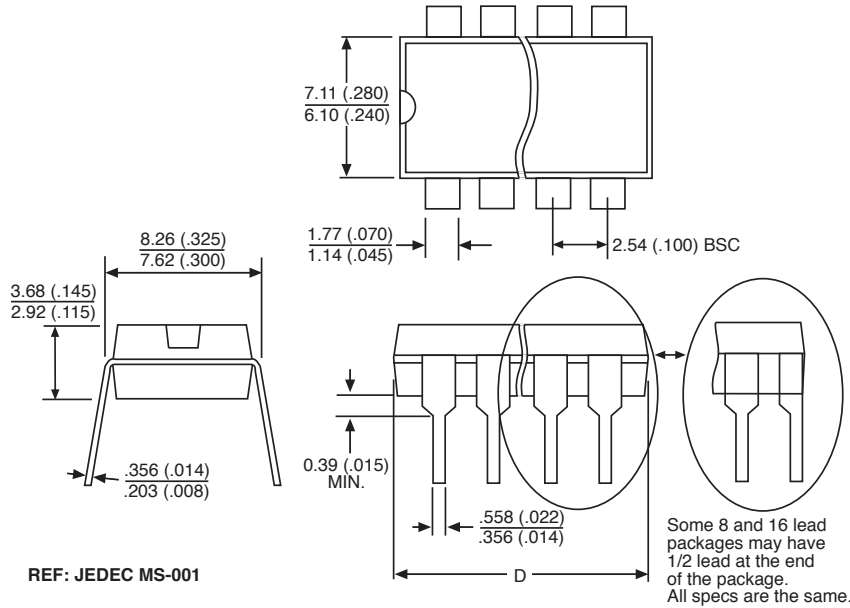

**Surface Mount Wide Body (DW); 300 mil wide**

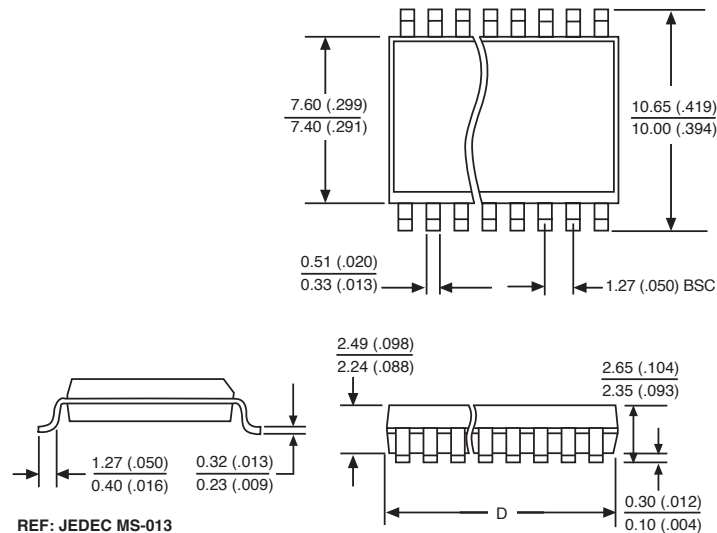

**Ordering Information**

Part Number	Description
CS4121ENF16	16L PDIP ( <i>internally fused leads</i> )
CS4121EDWF20	20L SOIC ( <i>internally fused leads</i> )
CS4121EDWFR20	20L SOIC ( <i>internally fused leads</i> ) ( <i>tape &amp; reel</i> )

Cherry Semiconductor Corporation reserves the right to make changes to the specifications without notice. Please contact Cherry Semiconductor Corporation for the latest available information.