



85mA Dual H-Bridge Odometer Driver with Divide by Select and UVLO

Description

The CS4161 is a Stepper Motor Driver that implements an H-Bridge design in order to drive two coils in an eight step sequence per revolution in the divide by 1 mode; 16 step sequence in the divide by 2 mode. The H-Bridge is capable of delivering 85mA to the load.

The sequencer insures that the odometer is monotonic. This sequencer is configured such that simultaneous conduction does not occur. Before each successive output sequence the part is taken through a state where both outputs are turned off individually. This

tends to minimize the inductive kick back energy that the part must absorb. On chip clamp diodes are across each output to protect the part from the kick back energy that it must absorb.

The CS4161 includes overvoltage and short circuit protection circuitry. It is lead for lead compatible with the CS-8441. The CS4161 includes an additional undervoltage lockout (UVLO) function which disables the output stage until the supply voltage rises above 5.6V, typically. The UVLO has hysteresis to prevent any power up glitching.

Features

- Undervoltage Lockout
 - Cross-conduction Prevention Logic
 - Divide by 1 and Divide by 2 Modes
 - Guaranteed Monotonic
 - On Chip Flyback Diodes
 - Fault Protection
- Overvoltage
Load Dump Protection to 60V

Absolute Maximum Ratings

Supply Voltage (V_{CC}) (continuous) -40°C to +105°C	-0.5 to 24V
(100ms pulse transient) -40°C to +105°C	-0.5 to 60V
Input Voltage (V_{IN})	-0.3 to $V_{CC} + 0.3V$
Operating Temperature Range	-40°C to 105°C
Storage Temperature Range (TSTG)	-65°C to 150°C
Junction Temperature Range	-40°C to 150°C
ESD (Human Body Model)	2kV
Lead Temperature Soldering	
Wave Solder (through hole styles only)	10 sec. max, 260°C peak

Package Option

8 Lead PDIP

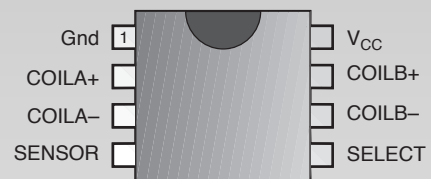

Block Diagram

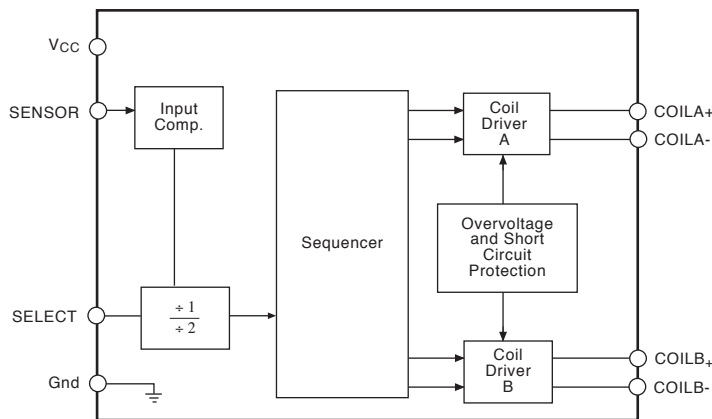

Electrical Characteristics: Unless otherwise stated, these specifications apply for $-40^{\circ}\text{C} \leq T_A \leq 105^{\circ}\text{C}$, $6.5\text{V} \leq V_{\text{CC}} \leq 15.5\text{V}$. All voltage shall be referenced to Gnd unless otherwise noted. Overvoltage shutdown of coils occurs when $V_{\text{CC}} > 16\text{V}$.

PARAMETER	TEST CONDITIONS	MIN	TYP	MAX	UNIT
■ Supply, V_{CC}					
Supply Voltage Range	$-40^{\circ}\text{C} \leq T_A \leq 105^{\circ}\text{C}$	6.5		15.5	V_{DC}
	$-40^{\circ}\text{C} \leq T_A \leq 25^{\circ}\text{C}$	6.5		24.0	V_{DC}
	Transient Pulse, 100ms			35.0	V_{DC}
Supply Current	$V_{\text{CC}} = 15.5 V_{\text{DC}}$, Outputs not loaded		24	35	mA
Overvoltage Shutdown		16		23	V
Undervoltage Lockout Voltage	V_{CC} Initial Power up	5.1	5.6	6.1	V
	UVLO Hysteresis	200	600	1000	mV
■ Speed Sensor Input, SENSOR					
Input Frequency Range			0.2	1.0	kHz
Switching Threshold		1.2		2.6	V_{DC}
Hysteresis		300	500		mV $_{\text{DC}}$
Input Bias Current	$0.8V_{\text{DC}} \leq V_{\text{IN}} \leq V_{\text{CC}}$		0.1	± 1.0	μA
Input Voltage Range		0		V_{CC}	V_{DC}
Operating Input Voltage	10k Ω Resistor in Series			-15 to V_{CC}	V_{DC}
Input Clamp Current	I Clamp at $V_{\text{IN}} = 0V_{\text{DC}}$		-0.4	-5.0	mA
■ Divider Select Input, SELECT					
Logic 0 Input Voltage				100	mV $_{\text{DC}}$
Logic 1 Input Voltage		3.0			V_{DC}
Logic 0 Input Current	$0\text{V} \leq V_{\text{IN}} \leq 100\text{mV}$		-1	-100	μA
Logic 1 Input Current	$3\text{V} \leq V_{\text{IN}} \leq 15.5 V_{\text{DC}}$		0.75	2.00	mA
■ Coil Output Drivers					
Coil Load	+25 $^{\circ}\text{C}$	198	210	222	Ω
Coil Inductance			80		mH
Coil Resistance Temperature	Coefficient			0.35	%/ $^{\circ}\text{C}$
* Energized Coil Voltage (Both Polarities) A and B	$V_{\text{CC}} = 6.5 V_{\text{DC}}$	$V_{\text{CC}} - 1.5\text{V}$	$V_{\text{CC}} - 0.9\text{V}$		V_{DC}
	$V_{\text{CC}} = 10.0 V_{\text{DC}}$	$V_{\text{CC}} - 1.6\text{V}$	$V_{\text{CC}} - 1.0\text{V}$		V_{DC}
	$V_{\text{CC}} = 15.5 V_{\text{DC}}$, $-20^{\circ}\text{C} \leq T_A \leq 105^{\circ}\text{C}$	$V_{\text{CC}} - 1.75\text{V}$	$V_{\text{CC}} - 1.1\text{V}$		V_{DC}
	$V_{\text{CC}} = 15.5 V_{\text{DC}}$, $-40^{\circ}\text{C} \leq T_A \leq -20^{\circ}\text{C}$	$V_{\text{CC}} - 2.0\text{V}$	$V_{\text{CC}} - 1.2\text{V}$		V_{DC}
De-energized Coil Leakage Current			± 100	μA	
■ Short Circuit Protection					
Short Circuit Threshold I Coil A + I Coil B			275	400	mA
Short Circuit Turn-Off Delay			5		μs

* Voltage across the coils shall be measured at the specific voltages, but shall also be within linearly interpolated limits.

Package Lead Description

PACKAGE LEAD #	LEAD SYMBOL	FUNCTION
8L PDIP		
1	Gnd	Ground connection.
2	COILA+	Output stage, when active, this lead supplies current to COIL A.
3	COILA-	Output stage, when active, this lead supplies current to COIL A.
4	SENSOR	Input signal from wheel speed or engine rpm.
5	SELECT	Selects divide by 1 or divide by 2 mode.
6	COILB-	Output stage, when active, this lead supplies current to COIL B.
7	COILB+	Output stage, when active, this lead supplies current to COIL B.
8	V_{CC}	Supply Voltage.

Speed Sensor Input

SENSOR is a PNP comparator input which accepts either a sine wave or a square wave input. This input is protected from excursions above V_{CC} as well as any below ground as long as the current is limited to 1.5mA. It has an active clamp set to zero volts to prevent negative input voltages from disrupting normal operation. The sensor input can withstand $150V_{DC}$ as long as the input current is limited to 1.5mA max. using a series resistor of $100k\Omega$.

Coil Driver Outputs

Simultaneously energizing the source and sink on either leg is not permitted, i.e. Q1 & Q2 or Q3 & Q4 cannot be energized simultaneously.

Circuit function is not affected by inductive transients due to coil loads as specified in the Transition States section.

The transition states occur as indicated in Table 1 without any intermediate states permitted.

Table 1: Transition States

State	Output State Table	
	Coil A	Coil B
0	+	+
1	OFF	+
2	-	+
3	-	OFF
4	-	-
5	OFF	-
6	+	-
7	+	OFF

The polarity definition for the coil driver outputs is as follows:

Polarity	Connect Coil +	Connect Coil -
Positive (+)	V_{CC}	Gnd
Negative (-)	Gnd	V_{CC}

Divider Select Input

The speed sensor input frequency is either divided by one or divided by two depending on the state of the SELECT input as follows:

Logic 0 = divide by 2

Logic 1 = divide by 1

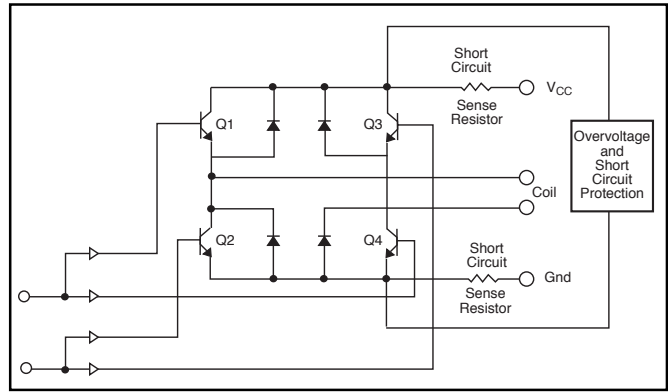

Figure 1: Coil Driver Output

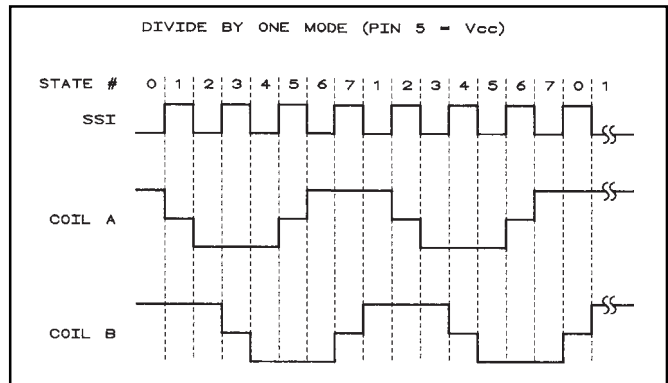

Figure 2: Divide by 1 SELECT Mode

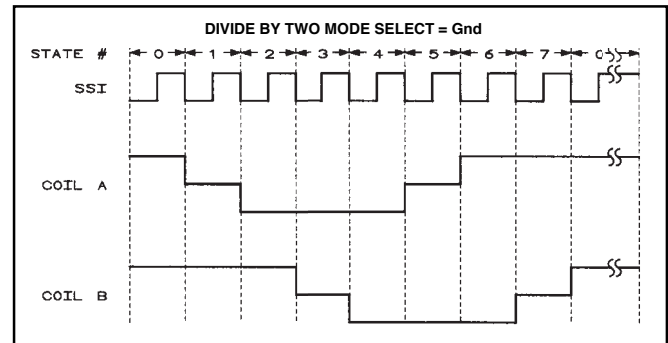
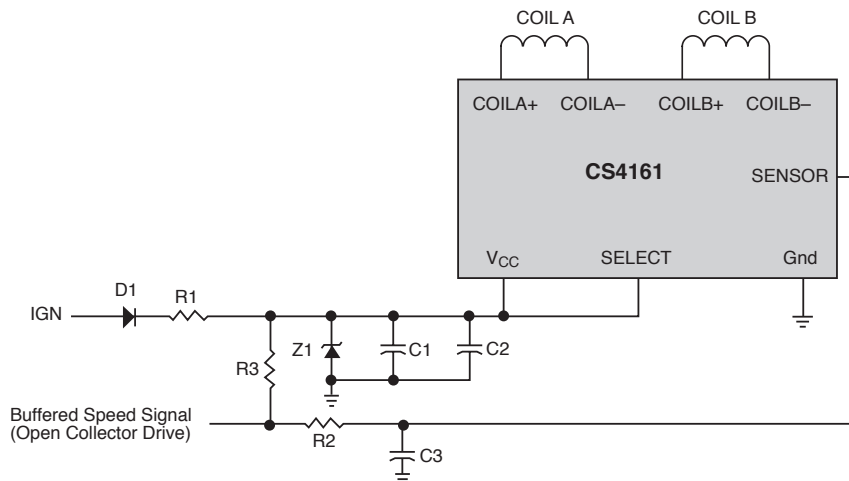

Figure 3: Divide by 2 SELECT Mode

Odometer Application Diagram

- C1 - $10\mu F$
- C2 - $0.1\mu F$
- C3 - $0.01\mu F$
- R1 - 3.9Ω , 500mW
- R2 - $100k\Omega$
- R3 - $15k\Omega$
- D1 - 1A, 600PIV
- Z1 - 50V, 500mW
- COIL A - $210 \pm 12\Omega$, 80mH
- COIL B - $210 \pm 12\Omega$, 80mH



Package Specification

PACKAGE DIMENSIONS IN mm (INCHES)

Lead Count	D			
	Metric		English	
	Max	Min	Max	Min
8L PDIP	10.16	9.02	.400	.355

PACKAGE THERMAL DATA

Thermal Data		8L PDIP	
$R_{\theta JC}$	typ	52	$^{\circ}C/W$
$R_{\theta JA}$	typ	100	$^{\circ}C/W$

Plastic DIP (N); 300 mil wide

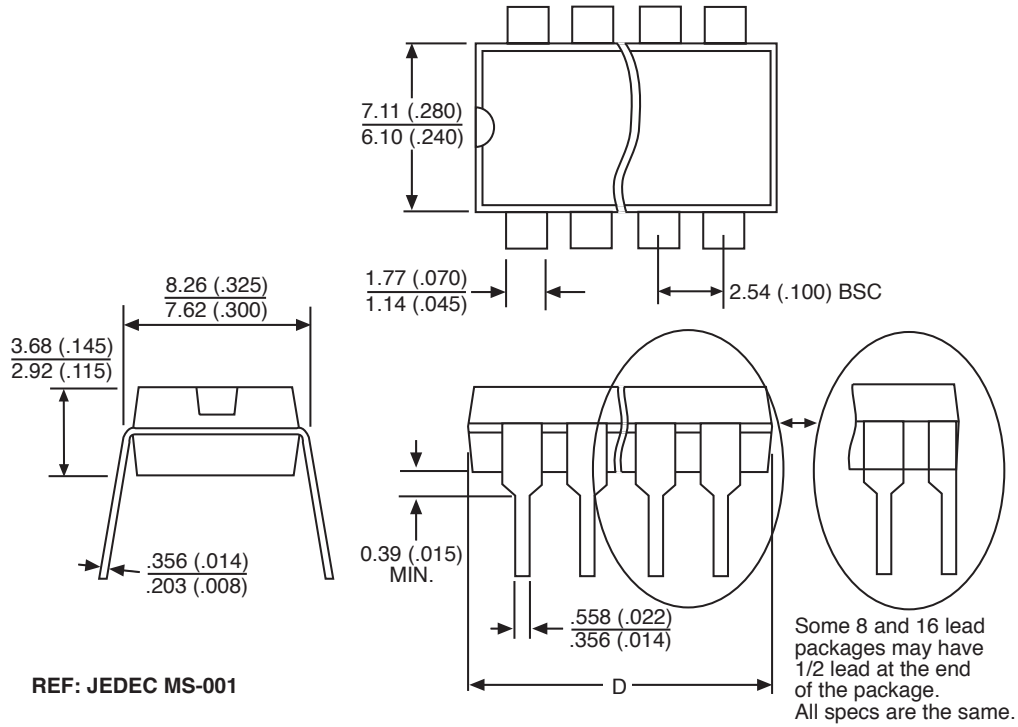

Ordering Information

Part Number	Description
CS4161XN8	8L PDIP

Cherry Semiconductor Corporation reserves the right to make changes to the specifications without notice. Please contact Cherry Semiconductor Corporation for the latest available information.