



# Digital PC to TV Encoder Features

## Features

- Support for low voltage interface to VGA controller
- Universal digital interface accepts YCrCb (CCIR656) or RGB (15, 16 or 24-bit multiplexed) video data in both non-interlaced and interlaced formats
- TrueScale™ rendering engine supports underscan operations for various graphic resolutions† ‡
- Enhanced text sharpness and adaptive flicker removal with up to 5-lines of filtering†
- Enhanced dot crawl control and area reduction
- Fully programmable through I<sup>2</sup>C port
- Supports NTSC, NTSC-EIA (Japan), and PAL (B, D, G, H, I, M and N) TV formats
- Provides Composite, S-Video and SCART outputs
- Auto-detection of TV presence
- Programmable power management
- 9-bit video DAC outputs
- Complete Windows and DOS driver software
- Offered in 44-pin PLCC, 44-pin TQFP

## General Description

Chronitel's CH7008 digital PC to TV encoder is a stand-alone integrated circuit which provides a PC 99 compliant solution for TV output on non-DVD enabled systems. Suggested application use with the Intel 810 chipset & Intel 810E chipset.\* It provides a universal digital input port to accept a pixel data stream from a compatible VGA controller (or equivalent) and converts this directly into NTSC or PAL TV format.

This circuit integrates a digital NTSC/PAL encoder with 9-bit DAC interface, and new adaptive flicker filter, and high accuracy low-jitter phase locked loop to create outstanding quality video. Through its TrueScale™ scaling and deflickering engine, the CH7008 supports full vertical and horizontal underscan capability and operates in 5 different resolutions including 640x480 and 800x600.

A new universal digital interface along with full programmability make the CH7008 ideal for system-level PC solutions. All features are software programmable through a standard I<sup>2</sup>C port, to enable a complete PC solution using a TV as the primary display.

† Patent number 5,781,241

‡ Patent number 5,914,753

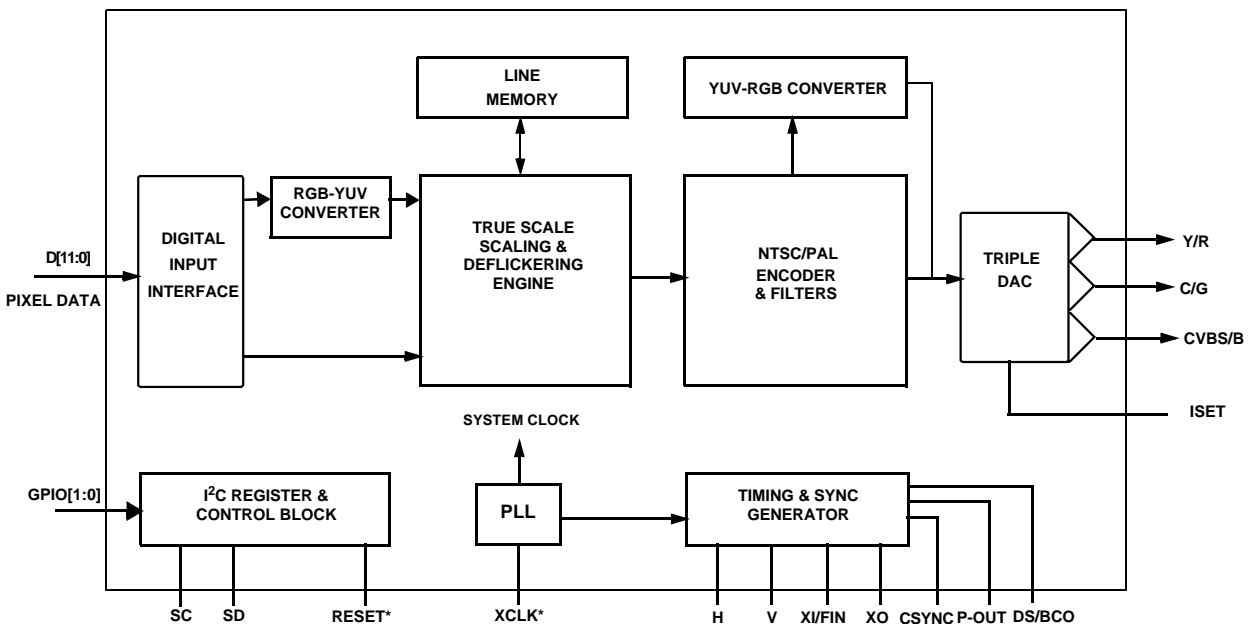

Figure 1: Functional Block Diagram

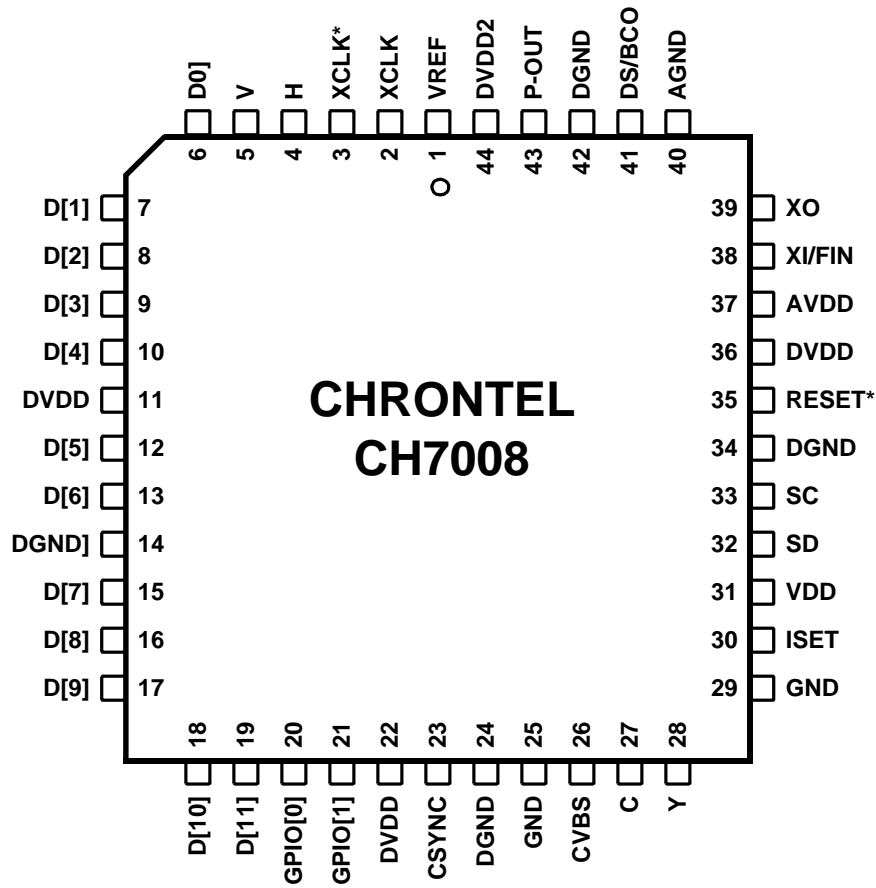

Figure 2: 44-Pin PLCC

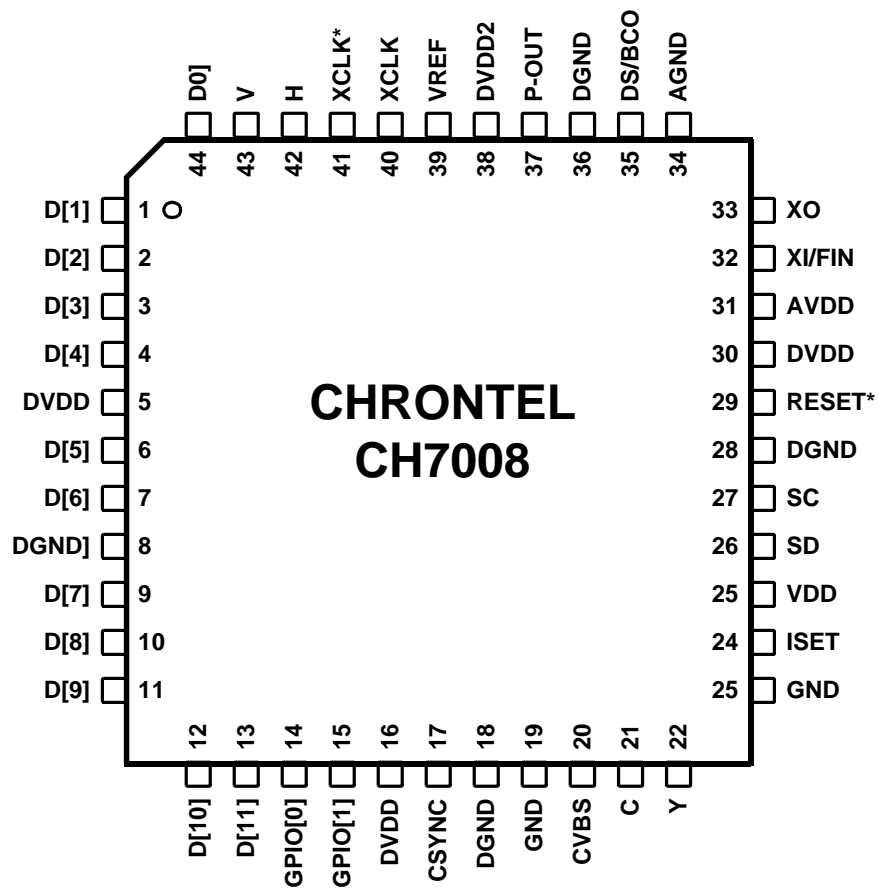

Figure 3: 44-Pin TQFP

Table 1. Pin Descriptions

44-Pin PLCC	44-Pin TQFP	Type	Symbol	Description
1	39	In/Out	VREF	<b>Reference Voltage Input</b> The VREF pin inputs a reference voltage of DVDD2/2. The signal is derived externally through a resistor divider and decoupling capacitor, and will be used as a reference level for data and sync inputs.
2	40	In	XCLK	<b>External Clock Input</b> This input along with XCLK* will form a differential clock input. For applications where a differential clock is not available, the XCLK* pin should be connected to the VREF pin.
3	41	In	XCLK*	<b>External Clock Input*</b> See XCLK description
4	42	In/Out	H	<b>Horizontal Sync Input/Output</b> When the SYO bit is low, this pin accepts a horizontal sync input. The level is 0 to DVDD2, with VREF as the threshold level.  When the SYO bit is high, the device will output a horizontal sync pulse. The output is driven from the DVDD supply.
5	43	In/Out	V	<b>Vertical Sync Input/Output</b> When the SYO bit is low, this pin accepts a vertical sync input. The level is 0 to DVDD2 with VREF as the threshold level.  When the SYO bit is high, the device will output a vertical sync pulse. The output is driven from the DVDD supply.
6-10,12-13,15-19	44,1-4,6-7,9-13	In	D[0]-D[11]	<b>Data [0] through Data [11] Inputs</b> These pins accept 12 data inputs from the graphics controller. The level is 0 to DVDD2, with VREF as the threshold level.
20-21	14-15	In/Out	GPIO[0] GPIO[1]	<b>General Purpose Input/Output [0-1] and Internal pull-up</b> These pins provide general purpose I/O's controlled via the IIC bus, registers 1Bh and 1Ch, bits 7 and 6. The internal pull-up is to the DVDD supply.
23	17	Out	CSYNC	<b>Composite Sync Output</b> A 75 Ω termination resistor with short traces should be attached between CSYNC and ground for optimum performance. In SCART mode, this pin outputs the composite sync signal.
26	20	Out	CVBS/B	<b>Composite Video Output/Blue Output</b> A 75 Ω termination resistor with short traces should be attached between CVBS and ground for optimum performance. In normal operating modes other than SCART, this pin outputs the composite video signal. In SCART mode, this pin outputs the blue signal.
27	21	Out	C/G	<b>Chroma Output/Green Output</b> A 75 Ω termination resistor with short traces should be attached between C and ground for optimum performance. In normal operating modes other than SCART, this pin outputs the chroma video signal. In SCART mode, this pin outputs the green signal.
28	22	Out	Y/R	<b>Luma Output / Red Output</b> A 75 Ω termination resistor with short traces should be attached between Y and ground for optimum performance. In normal operating modes other than SCART, this pin outputs the luma video signal. In SCART mode, this pin outputs the red signal.
30	24	In	ISET	<b>Current Set Resistor Input</b> This pin sets the DAC current. A 360 ohm resistor should be connected between this pin and GND using short and wide traces.

Table 1. Pin Descriptions

44-Pin PLCC	44-Pin TQFP	Type	Symbol	Description
32	26	In/Out	SD	<b>Serial Data Input/Output</b> This pin functions as the serial data pin of the I <sup>2</sup> C interface port, and uses the DVDD supply. (see the I <sup>2</sup> C Port Operation section for details)
33	27	In	SC	<b>Serial Clock Input</b> This pin functions as the serial clock pin of the I <sup>2</sup> C interface port, and uses the DVDD supply. (see the I <sup>2</sup> C Port Operation section for details)
35	29	In	RESET*	<b>Reset* Input</b> When this pin is low, the CH7008 is held in the power-on reset condition. When this pin is high, the device operates normally and reset is controlled through the I <sup>2</sup> C register.
38	32	In	XI/FIN	<b>Crystal Input/External Reference Input</b> A parallel resonance 14.31818MHz crystal should be attached between this pin and XO. However, an external CMOS clock can be attached to XI/FIN.
39	33	Out	XO	<b>Crystal Output</b> A parallel resonance 14.31818MHz ±20ppm crystal should be attached between this pin and XI/FIN. However, if an external CMOS clock is attached to XI/FIN, XO should not be connected.
41	35	In/Out	DS/BCO	<b>Data start (input)/Buffered Clock (output)</b> In normal operating modes, when configured as an input, the rising edge of this signal identifies the first active pixel of data for each active line. The level is 0 to DVDD2, with VREF as the threshold level.  When configured as an output this pin provides a buffered clock output, driven by the DVDD supply. The output clock can be selected using the BCO register (17th) (see Registers and Programing).
43	37	Out	P-OUT	<b>Pixel Clock Output</b> This pin provides a pixel clock signal to the VGA controller (adjustable as 1X, 2X and 3X) and is driven from the DVDD2 supply. This clock will only be provided in master clock modes, and will be tri-stated otherwise, (see the section on Digital Video Interface and Registers and Programming for more details). The capacitive loading on this pin should be kept to a minimum.
11,22,36	5,16,30	Power	DVDD	<b>Digital Supply Voltage</b>
14,24,34,42	8,18,28,36	Power	DGND	<b>Digital Ground</b>
25,29	19,23	Power	GND	<b>DAC</b>
31	25	Power	VDD	<b>DAC Supply Voltage</b>
37	31	Power	AVDD	<b>PLL Supply Voltage</b>
40	34	Power	AGND	<b>PLL Ground</b>
44	38	Power	DVDD2	<b>I/O SUPPLY VOLTAGE</b> Digital supply voltage for the P-OUT

**Digital Video Interface**

The CH7008 digital video interface provides a flexible digital interface between a computer graphics controller and the TV encoder IC forming the ideal quality/cost configuration for performing the TV-output function. This digital interface consists of up to 12 data signals and 4 control signals, all of which are subject to programmable control through the CH7008 register set. This interface can be configured as 8 or 12-bit inputs operating in multiplexed mode. It will also accept either YCrCb or RGB (15, 16 or 24-bit color depth) data formats and will accept both non-interlaced and interlaced data formats. A summary of the input data format modes is as follows:

**Table 2. Input Data Formats**

Bus Width	Transfer Mode	Color Space and Depth	Format Reference
8-bit	2X-multiplexed	RGB 15-bit	5-5-5 over two bytes
8-bit	2X-multiplexed	RGB 16-bit	5-6-5 over two bytes
8-bit	2X-multiplexed	YCrCb (24-bit)	Cb,Y0,Cr,Y1,(CCIR656 style)
12-bit	2X-multiplexed	RGB 24	8-8-8 over two words - 'C' version
12-bit	2X-multiplexed	RGB 24	8-8-8 over two words - 'I' version

The clock and timing signals used to latch and process the incoming pixel data is dependent upon the clock mode. The CH7008 can operate in either master (the CH7008 generates a pixel frequency which is either returned as a phase-aligned pixel clock or used directly to latch data), or slave mode (the graphics chip generates the pixel clock). The pixel clock frequency will change depending upon the active image size (e.g., 640x480 or 800x600), the desired output format (NTSC or PAL), and the amount of scaling desired. The pixel clock may be requested to be 1X, 2X or 3X the pixel data rate (subject to a 100MHz frequency limitation). In the case of a 1X pixel clock the CH7008 will automatically use both clock edges, if a multiplexed data format is selected.

**Sync Signals:** Horizontal and vertical sync signals will normally be supplied by the VGA controller, but may be selected to be generated by the CH7008. In the case of CCIR656 style input (IDF = 9), embedded sync may also be used. In each case, the period of the horizontal sync should be equal to the duration of the pixel clock, times the first value of the (*Total Pixels/line x Total Lines/Frame*) column of **Table 13** on page 29 (Display Mode Register 00H description). The leading edge of the horizontal sync is used to determine the start of each line. The Vertical sync signal must be able to be set to the second value in the (*Total Pixels/Line x Total Lines/Frame*) column of **Table 13** on page 29.

**Master Clock Mode:** The CH7008 generates a clock signal (output at the P-OUT pin) which will be used by the VGA controller as a frequency reference. The VGA controller will then generate a clock signal which will be input via the XCLK input. This incoming signal will be used to latch (and de-multiplex, if required) incoming data. The XCLK input clock rate must match the input data rate, and the P-OUT clock can be requested to be 1X, 2X or 3X the pixel data rate. As an alternative, the P-OUT clock signal can also be used as the input clock signal (connected directly to the XCLK input) to latch the incoming data. If this mode is used, the incoming data must meet setup and hold times with respect to the XCLK input (with the only internal adjustment being XCLK polarity).

**Slave Clock Mode:** The VGA controller will generate a clock which will be input to the XCLK pin (no clock signal will be output on the P-OUT pin). This signal must match the input data rate, must occur at 1X, 2X or 3X the pixel data rate, and will be used to latch (and de-multiplex if required) incoming data. Also, the graphics IC transmits back to the TV encoder the horizontal and vertical timing signals, and pixel data, each of which must meet the specified setup and hold times with respect to the pixel clock.

**Pixel Data:** Active pixel data will be expected after a programmable number pixels times the multiplex rate after the leading edge of Horizontal Sync. In other words, specifying the horizontal back porch value (as a pixel count), plus horizontal sync width, will determine when the chip will begin to sample pixels.

### Input Data Formats

The XCLK and XCLK\* signals are used to latch data from the graphics chip. Data can be latched coincident with the rising edge of XCLK, falling edge of XCLK, or both edges, depending upon register settings of XCM and MCP. The input data format is shown in **Figure 4**. The Pixel Data bus represents an 8 or 12-bit multiplexed data stream, which contains either RGB or YCrCb formatted data. In IDF settings of 4, 5, 7, 8 and 9, the input data rate is 2X pixel clock, and each pair of Pn values (e.g., P0a and P0b) will contain a complete pixel, encoded as shown in the tables below. When the input is YCrCb, the color-difference data will be transmitted at half the data rate of the luminance data, with the sequence being set as Cb0, Y0, Cr0, Y1 where Cb0, Y0, Cr0 refers to co-sited luminance and color-difference samples — and the following Y1 byte refers to the next luminance sample, per CCIR656 standards. However, the clock frequency is dependent upon the current mode, not 27MHz, as specified in CCIR656.

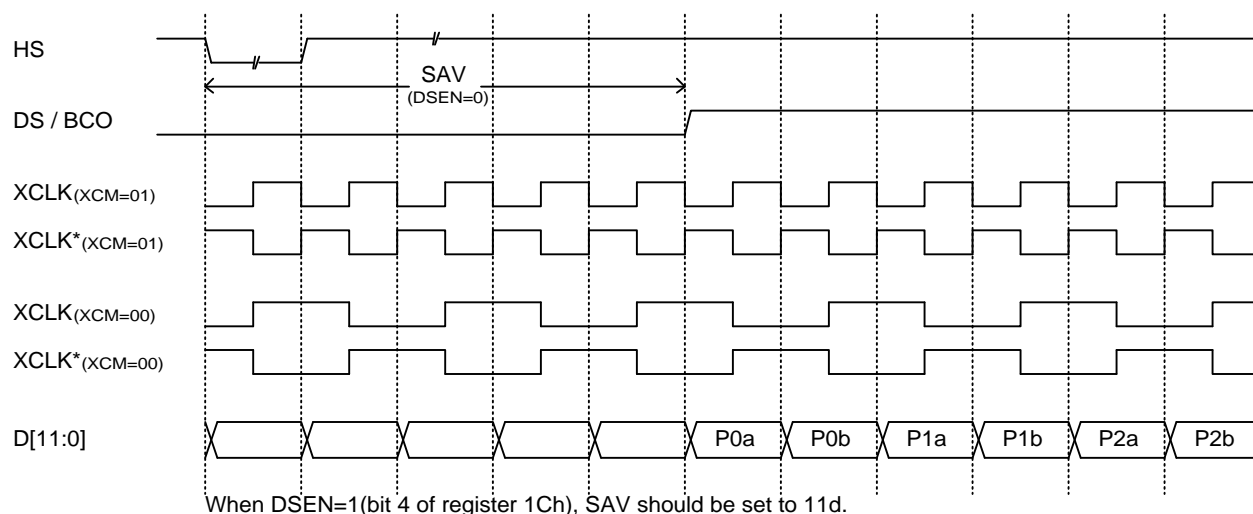

**Figure 4: Non-multiplexed Data Transfers**

**Table 3. RGB 8-bit Multiplexed Mode**

IDF# Format	Pixel#	7 RGB 5-6-5				8 RGB 5-5-5			
		P0a	P0b	P1a	P1b	P0a	P0b	P1a	P1b
Bus Data	D[7]	G0[2]	R0[4]	G1[2]	R1[4]	G0[2]	x	G1[2]	x
	D[6]	G0[1]	R0[3]	G1[1]	R1[3]	G0[1]	R0[4]	G1[1]	R1[4]
	D[5]	G0[0]	R0[2]	G1[0]	R1[2]	G0[0]	R0[3]	G1[0]	R1[3]
	D[4]	B0[4]	R0[1]	B1[4]	R1[1]	B0[4]	R0[2]	B1[4]	R1[2]
	D[3]	B0[3]	R0[0]	B1[3]	R1[0]	B0[3]	R0[1]	B1[3]	R1[1]
	D[2]	B0[2]	G0[5]	B1[2]	G1[5]	B0[2]	R0[0]	B1[2]	R1[0]
	D[1]	B0[1]	G0[4]	B1[1]	G1[4]	B0[1]	G0[4]	B1[1]	G1[4]
	D[0]	B0[0]	G0[3]	B1[0]	G1[3]	B0[0]	G0[3]	B1[0]	G1[3]

**Table 4. RGB 12-bit Multiplexed Mode**

IDF# Format	Pixel#	4 12-bit RGB (12-12)				5 12-bit RGB (12-12)			
		P0a	P0b	P1a	P1b	P0a	P0b	P1a	P1b
Bus Data	D[11]	G0[3]	R0[7]	G1[3]	R1[7]	G0[4]	R0[7]	G1[4]	R1[7]
	D[10]	G0[2]	R0[6]	G1[2]	R1[6]	G0[3]	R0[6]	G1[3]	R1[6]
	D[9]	G0[1]	R0[5]	G1[1]	R1[5]	G0[2]	R0[5]	G1[2]	R1[5]
	D[8]	G0[0]	R0[4]	G1[0]	R1[4]	B0[7]	R0[4]	B1[7]	R1[4]
	D[7]	B0[7]	R0[3]	B1[7]	R1[3]	B0[6]	R0[3]	B1[6]	R1[3]
	D[6]	B0[6]	R0[2]	B1[6]	R1[2]	B0[5]	G0[7]	B1[7]	G1[7]
	D[5]	B0[5]	R0[1]	B1[5]	R1[1]	B0[4]	G0[6]	B1[4]	G1[6]
	D[4]	B0[4]	R0[0]	B1[4]	R1[0]	B0[3]	G0[5]	B1[3]	G1[5]
	D[3]	B0[3]	G0[7]	B1[3]	G1[7]	G0[0]	R0[2]	G1[0]	R1[2]
	D[2]	B0[2]	G0[6]	B1[2]	G1[6]	B0[2]	R0[1]	B1[2]	R1[1]
	D[1]	B0[1]	G0[5]	B1[1]	G1[5]	B0[1]	R0[0]	B1[1]	R1[0]
	D[0]	B0[0]	G0[4]	B1[0]	G1[4]	B0[0]	G0[1]	B1[0]	G1[1]

**Table 5. YCrCb Multiplexed Mode**

IDF# Format	Pixel#	9 YCrCb 8-bit							
		P0a	P0b	P1a	P1b	P2a	P2b	P3a	P3b
Bus Data	D[7]	Cb0[7]	Y0[7]	Cr0[7]	Y1[7]	Cb2[7]	Y2[7]	Cr2[7]	Y3[7]
	D[6]	Cb0[6]	Y0[6]	Cr0[6]	Y1[6]	Cb2[6]	Y2[6]	Cr2[6]	Y3[6]
	D[5]	Cb0[5]	Y0[5]	Cr0[5]	Y1[5]	Cb2[5]	Y2[5]	Cr2[5]	Y3[5]
	D[4]	Cb0[4]	Y0[4]	Cr0[4]	Y1[4]	Cb2[4]	Y2[4]	Cr2[4]	Y3[4]
	D[3]	Cb0[3]	Y0[3]	Cr0[3]	Y1[3]	Cb2[3]	Y2[3]	Cr2[3]	Y3[3]
	D[2]	Cb0[2]	Y0[2]	Cr0[2]	Y1[2]	Cb2[2]	Y2[2]	Cr2[2]	Y3[2]
	D[1]	Cb0[1]	Y0[1]	Cr0[1]	Y1[1]	Cb2[1]	Y2[1]	Cr2[1]	Y3[1]
	D[0]	Cb0[0]	Y0[0]	Cr0[0]	Y1[0]	Cb2[0]	Y2[0]	Cr2[0]	Y3[0]



When IDF = 9, (YCrCb 8-bit mode), H and V sync signals can be embedded into the data stream. In this mode, the embedded sync will be similar to the CCIR656 convention, and the first byte of the ‘video timing reference code’ will be assumed to occur when a Cb sample would occur – if the video stream was continuous. This is delineated in **Table 6** shown below.

**Table 6. YCrCb Multiplexed Mode with Embedded Syncs**

IDF# Format	Pixel#	9 YCrCb 8-bit							
		P0a	P0b	P1a	P1b	P2a	P2b	P3a	P3b
Bus Data	D[7]	1	0	0	S[7]	Cb2[7]	Y2[7]	Cr2[7]	Y3[7]
	D[6]	1	0	0	S[6]	Cb2[6]	Y2[6]	Cr2[6]	Y3[6]
	D[5]	1	0	0	S[5]	Cb2[5]	Y2[5]	Cr2[5]	Y3[5]
	D[4]	1	0	0	S[4]	Cb2[4]	Y2[4]	Cr2[4]	Y3[4]
	D[3]	1	0	0	S[3]	Cb2[3]	Y2[3]	Cr2[3]	Y3[3]
	D[2]	1	0	0	S[2]	Cb2[2]	Y2[2]	Cr2[2]	Y3[2]
	D[1]	1	0	0	S[1]	Cb2[1]	Y2[1]	Cr2[1]	Y3[1]
	D[0]	1	0	0	S[0]	Cb2[0]	Y2[0]	Cr2[0]	Y3[0]

In this mode, the S[7:0] byte contains the following data:

S[6] = F = 1 during field 2, 0 during field 1  
 S[5] = V = 1 during field blanking, 0 elsewhere  
 S[4] = H = 1 during EAV (the synchronization reference at the end of active video)  
 0 during SAV (the synchronization reference at the start of active video)

Bits S[7] and S[3-0] are ignored.

## Functional Description

The CH7008 is a TV-output companion chip to graphics controllers providing digital output in either YCrCb or RGB format. This solution involves both hardware and software elements which work together to produce an optimum TV screen image based on the original computer generated pixel data. All essential circuitry for this conversion are integrated on chip. On chip circuitry includes memory, memory control, scaling, PLL, DAC, filters and NTSC/PAL encoder. All internal signal processing, including NTSC/PAL encoding, is performed using digital techniques to ensure that the high-quality video signals are not affected by drift issues associated with analog components. No additional adjustment is required during manufacturing.

CH7008 is ideal for PC motherboards, web browsers or VGA add-in boards where a minimum of discrete support components (passive components, parallel resonance 14.31818 MHz crystal) are required for full operation.

## Architectural Overview

The CH7008 is a complete TV output subsystem which uses both hardware and software elements to produce an image on TV which is virtually identical to the image that would be displayed on a monitor. Simply creating a compatible TV output from a VGA input involves a relatively straightforward process. This process includes a standard conversion from RGB to YUV color space, converting from a non-interlaced to an interlaced frame sequence, and encoding the pixel stream into NTSC or PAL compliant format. However, creating an optimum computer-generated image on a TV screen involves a highly sophisticated process of scaling, deflickering, and filtering. This results in a compatible TV output that displays a sharp and subtle image, of the right size, with minimal artifacts from the conversion process.

As a key part of the overall system solution, the CH7008 software establishes the correct framework for the VGA input signal to enable this process. Once the display is set to a supported resolution (either 640x480 or 800x600), the CH7008 software may be invoked to establish the appropriate TV output display. The software then programs the various timing parameters of the VGA controller to create an output signal that will be compatible with the chosen resolution, operating mode, and TV format. Adjustments performed in software include pixel clock rates, total pixels per line, and total lines per frame. By performing these adjustments in software, the CH7008 can render a superior TV image without the added cost of a full frame buffer memory – normally used to implement features such as scaling and full synchronization.

The CH7008 hardware accepts digital RGB or YCrCb inputs, which are latched in synchronization with the pixel clock. These inputs are then color-space converted into YUV in 4-2-2 format, and stored in a line buffer memory. The stored pixels are fed into a block where scan-rate conversion, underscan scaling and 2-line, 3-line, 4-line or 5-line vertical flicker filtering are performed. The scan-rate converter transforms the VGA horizontal scan-rate to either NTSC or PAL scan rates; the vertical flicker filter eliminates flicker at the output while the underscan scaling reduces the size of the displayed image to fit onto a TV screen. The resulting YUV signals are filtered through digital filters to minimize aliasing problems. The digital encoder receives the filtered signals and transforms them to composite and S-Video outputs, which are converted by the three 9-bit DACs into analog outputs.

## Color Burst Generation\*

The CH7008 allows the subcarrier frequency to be accurately generated from a 14.31818 MHz crystal oscillator, leaving the subcarrier frequency independent of the sampling rate. As a result, the CH7008 may be used with any VGA chip (with an appropriate digital interface) since the CH7008 subcarrier frequency can be generated without being dependent on the precise pixel rates of VGA controllers. This feature is a significant benefit, since even a  $\pm 0.01\%$  subcarrier frequency variation may be enough to cause some television monitors to lose color lock.

In addition, the CH7008 has the capability to genlock the color burst signal to the VGA horizontal sync frequency, which enables a fully synchronous system between the graphics controller and the television. When genlocked, the CH7008 can also stop “dot crawl” motion (for composite mode operation in NTSC modes) to eliminate the annoyance of moving borders. Both of these features are under programmable control through the register set.

## Display Modes

The CH7008 display mode is controlled by three independent factors: input resolution, TV format, and scale factor, which are programmed via the display mode register. It is designed to accept input resolutions of 640x480, 800x600, 640x400 (including 320x200 scan-doubled output), 720x400 and 512x384.

**Display Modes (continued)**

It is designed to support output to either NTSC or PAL television formats. The CH7008 provides interpolated scaling with selectable factors of 5:4, 1:1, 7:8, 5:6, 3:4 and 7:10 in order to support adjustable overscan or underscan operation when displayed on a TV. This combination of factors results in a matrix of useful operating modes which are listed in detail in **Table 7**.

**Table 7. CH7008 Display Modes**

TV Format Standard	Input (active) Resolution	Scale Factor	Active TV Lines	Percent (1) Overscan	Pixel Clock	Horizontal Total	Vertical Total
NTSC	640x480	1:1	480	10%	24.671	784	525
NTSC	640x480	7:8	420	(3%)	28.196	784	600
NTSC	640x480	5:6	400	(8%)	30.210	800	630
NTSC	800x600	5:6	500	16%	39.273	1040	630
NTSC	800x600	3:4	450	4%	43.636	1040	700
NTSC	800x600	7:10	420	(3%)	47.832	1064	750
NTSC	640x400	5:4	500	16%	21.147	840	420
NTSC	640x400	1:1	400	(8%)	26.434	840	525
NTSC	640x400	7:8	350	(19%)	30.210	840	600
NTSC	720x400	5:4	500	16%	23.790	945	420
NTSC	720x400	1:1	400	(8%)	29.455	936	525
NTSC	512x384	5:4	480	10%	20.140	800	420
NTSC	512x384	1:1	384	(11%)	24.671	784	525
PAL	640x480	5:4	600	14%	21.000	840	500
PAL	640x480	1:1	480	(8%)	26.250	840	625
PAL	640x480	5:6	400	(29%)	31.500	840	750
PAL	800x600	1:1	600	14%	29.500	944	625
PAL	800x600	5:6	500	(4%)	36.000	960	750
PAL	800x600	3:4	450	(15%)	39.000	936	836
PAL	640x400	5:4	500	(4%)	25.000	1000	500
PAL	640x400	1:1	400	(29%)	31.500	1008	625
PAL	720x400	5:4	500	(4%)	28.125	1125	500
PAL	720x400	1:1	400	(29%)	34.875	1116	625
PAL	512x384	5:4	480	(8%)	21.000	840	500
PAL	512x384	1:1	384	(35%)	26.250	840	625

**(1) Note:** Percent underscan is a calculated value based on average viewable lines on each TV format, assuming an average TV overscan of 10%. (Negative values) indicate modes which are operating in underscan.

For NTSC: 480 active lines - 10% (overscan) = 432 viewable lines (average)

For PAL: 576 active lines - 10% (overscan) = 518 viewable lines (average)

The inclusion of multiple levels of scaling for each resolution have been created to enable optimal use of the CH7008 for different application needs. In general, underscan (modes where percent overscan is negative) provides an image that is viewable in its entirety on screen; it should be used as the default for most applications (e.g., viewing text screens, operating games, running productivity applications and working within Windows). Overscanning provides an image that extends past the edges of the TV screen, exactly like normal television programs and movies appear on TV, and is only recommended for viewing movies or video clips coming from the computer. In addition to the above mode table, the CH7008 also support interlaced input modes, both in CCIR 656 and proprietary formats (see Display Mode Register section).

**Flicker Filter and Text Enhancement**

The CH7008 integrates an advanced 2-line, 3-line, 4-line and 5-line (depending on mode) vertical deflickering filter circuit to help eliminate the flicker associated with interlaced displays. This flicker circuit provides an adaptive filter algorithm for implementing flicker reduction with selections of high, medium or low flicker content for both luma and chroma channels (see register descriptions). In addition, a special text enhancement circuit incorporates

**Display Modes (continued)**

additional filtering for enhancing the readability of text. These modes are fully programmable via I<sup>2</sup>C under the flicker filter register.

**Internal Voltage Reference**

An on chip bandgap circuit is used in the DAC to generate a reference voltage which, in conjunction with a reference resistor at pin ISET, and register controlled divider, sets the output ranges of the DACs. The CH7008 bandgap reference voltage is 1.235 volts nominal for NTSC or PAL-M, or 1.317 volts nominal for PAL or NTSC-J, which is determined by IDF register bit 6 (DACG bit). The recommended value for the reference resistor from ISET to ground is 360 ohms (though this may be adjusted in order to achieve a different output level). The gain setting for DAC output is 1/48<sup>th</sup>. Therefore, for each DAC, the current output per LSB step is determined by the following equation:

$$I_{LSB} = V(ISET)/ISET \text{ reference resistor} * 1/GAIN$$

For DACG=0, this is:  $I_{LSB} = 1.235/360 * 1/48 = 71.4 \mu A$  (nominal)  
 For DACG=1, this is:  $I_{LSB} = 1.317/360 * 1/48 = 76.2 \mu A$  (nominal)

**Power Management**

The CH7008 supports five operating states including Normal [On], Power Down, Full Power Down, S-Video Off and Composite Off to provide optimal power consumption for the application involved. Using the programmable power down modes accessed over the I<sup>2</sup>C port, the CH7008 may be placed in either Normal state, or any of the four power managed states, as listed below (see “Power Management Register” under the *Register Descriptions* section for programming information). To support power management, a TV sensing function (see “Connection Detect Register” under the *Register Descriptions* section) is provided, which identifies whether a TV is connected to either S-Video or composite. This sensing function can then be used to enter into the appropriate operating state (e.g., if TV is sensed only on composite, the S-Video Off mode could be set by software).

**Table 8. Power Management**

Operating State	Functional Description
Normal (On):	In the normal operating state, all functions and pins are active.
Power Down:	In the power-down state, most pins and circuitry are disabled. The DS/BCO pin will continue to provide either the VCO divided by K3, or 14.318 MHz out when selected as an output, and the P-OUT pin will continue to output a clock reference when in master clock mode.
S-Video Off:	Power is shut off to the unused DACs associated with S-Video outputs.
Composite Off:	In Composite-off state, power is shut off to the unused DAC associated with CVBS output.
Full Power Down:	In this power-down state, all but the I <sup>2</sup> C circuits are disabled. This places the CH7008 in its lowest power consumption mode.

**Luminance and Chrominance Filter Options**

The CH7008 contains a set of luminance filters to provide a controllable bandwidth output on both CVBS and S-Video outputs. All values are completely programmable via the Video Bandwidth Register. For all graphs shown, the horizontal axis is frequency in MHz, and the vertical axis is attenuation in dBs. The composite luminance and chrominance video bandwidth output is shown in **Table 9**.

**Table 9. Video Bandwidth**

Mode	Chrominance				Luminance Bandwidth with Sin(X) /X (MHz)							
					CVBS		S-Video			S-Video		
	CBW[1:0]				YCV		YSV[1:0], YPEAK = 0			YSV[1:0], YPEAK = 1		
	00	01	10	11	0	1	00	01	1X	00	01	1X
0	0.62	0.68	0.80	0.95	2.26	3.37	2.26	3.37	5.23	2.57	4.44	5.23
1	0.78	0.85	1.00	1.18	2.82	4.21	2.82	4.21	6.53	3.21	5.56	6.53
2	0.53	0.58	0.68	0.81	1.93	2.87	1.93	2.87	4.46	2.19	3.79	4.46
3	0.65	0.71	0.83	0.99	2.36	3.52	2.36	3.52	5.46	2.68	4.64	5.46
4	0.83	0.91	1.07	1.27	3.03	4.51	3.03	4.51	7.00	3.44	5.95	7.00
5	1.03	1.13	1.32	1.57	3.75	5.59	3.75	5.59	8.68	4.27	7.38	8.68
6	0.70	0.77	0.90	1.07	2.56	3.81	2.56	3.81	5.92	2.91	5.04	5.92
7	0.87	0.95	1.12	1.33	3.17	4.72	3.17	4.72	7.33	3.60	6.23	7.33
8	0.74	0.81	0.95	1.13	2.69	4.01	2.69	4.01	6.22	3.06	5.29	6.22
9	0.93	1.02	1.20	1.42	3.39	5.05	3.39	5.05	7.84	3.85	6.67	7.84
10	0.63	0.68	0.80	0.95	2.28	3.39	2.28	3.39	5.26	2.59	4.48	5.26
11	0.78	0.86	1.00	1.19	2.84	4.24	2.84	4.24	6.58	3.23	5.59	6.58
12	0.89	0.98	1.15	1.36	3.25	4.84	3.25	4.84	7.52	3.70	6.39	7.52
13	0.62	0.68	0.80	0.95	2.26	3.37	2.26	3.37	5.23	2.57	4.44	5.23
14	0.78	0.85	1.00	1.18	2.82	4.21	2.82	4.21	6.53	3.21	5.56	6.53
15	0.93	1.02	1.20	1.42	3.39	5.05	3.39	5.05	7.84	3.85	6.67	7.84
16	0.64	0.71	0.83	0.98	2.35	3.50	2.35	3.50	5.43	2.67	4.62	5.43
17	0.74	0.81	0.95	1.13	2.70	4.02	2.70	4.02	6.24	3.07	5.30	6.24
18	0.79	0.87	1.02	1.21	2.89	4.31	2.89	4.31	6.68	3.29	5.68	6.68
19	0.77	0.85	1.00	1.18	2.82	4.20	2.82	4.20	6.53	3.21	5.55	6.53
20	0.95	1.03	1.22	1.44	3.44	5.13	3.44	5.13	7.97	3.92	6.77	7.97
21	1.02	1.12	1.32	1.56	3.73	5.56	3.73	5.56	8.63	4.24	7.34	8.63
22	0.77	0.85	0.99	1.18	2.82	4.20	2.82	4.20	6.52	3.20	5.54	6.52
23	0.86	0.94	1.11	1.31	3.13	4.66	3.13	4.66	7.24	3.56	6.16	7.24
24	0.94	1.03	1.21	1.44	3.43	5.11	3.43	5.11	7.94	3.90	6.75	7.94
25	0.71	0.78	0.91	1.08	2.58	3.85	2.58	3.85	5.97	2.94	5.08	5.97
26	0.71	0.78	0.91	1.08	2.58	3.85	2.58	3.85	5.97	2.94	5.08	5.97

The composite luminance and chrominance frequency response is depicted in **Figures 5** through **7**.

Luminance and Chrominance Filter Options (continued)

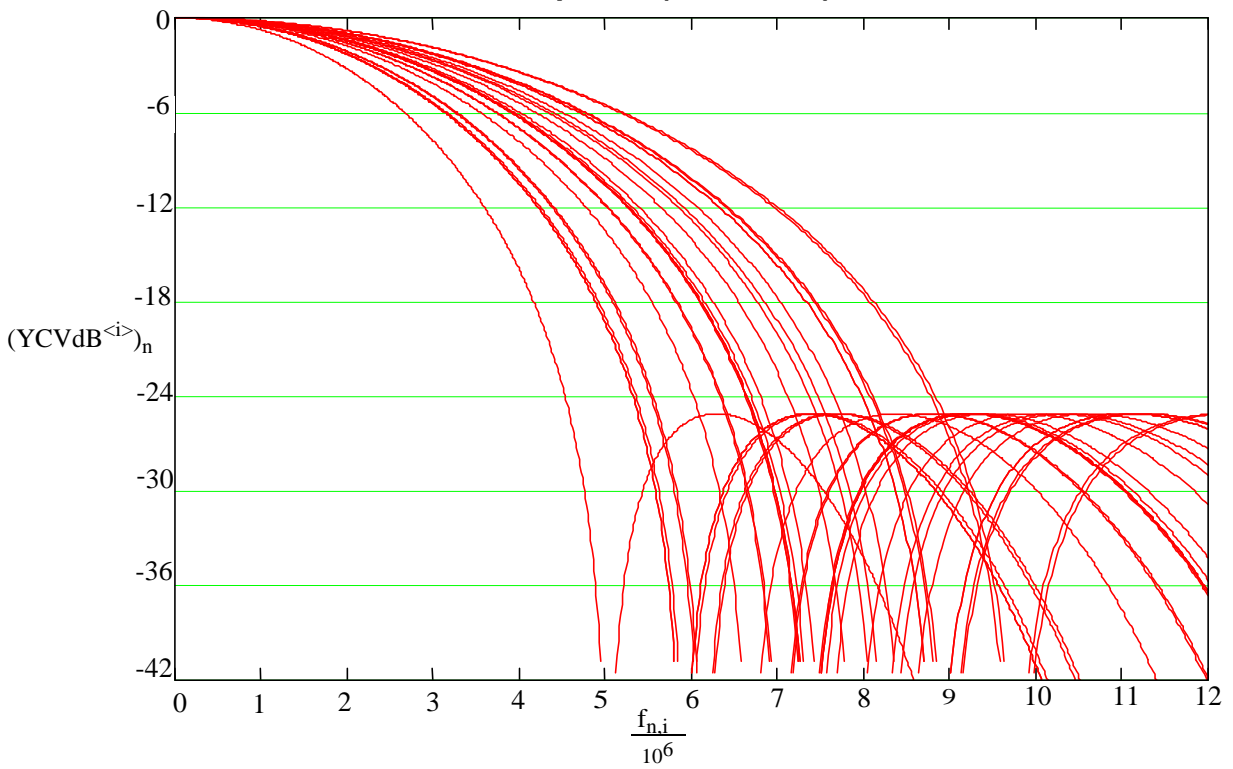

Figure 5: Composite Luminance Frequency Response (YCV = 0)

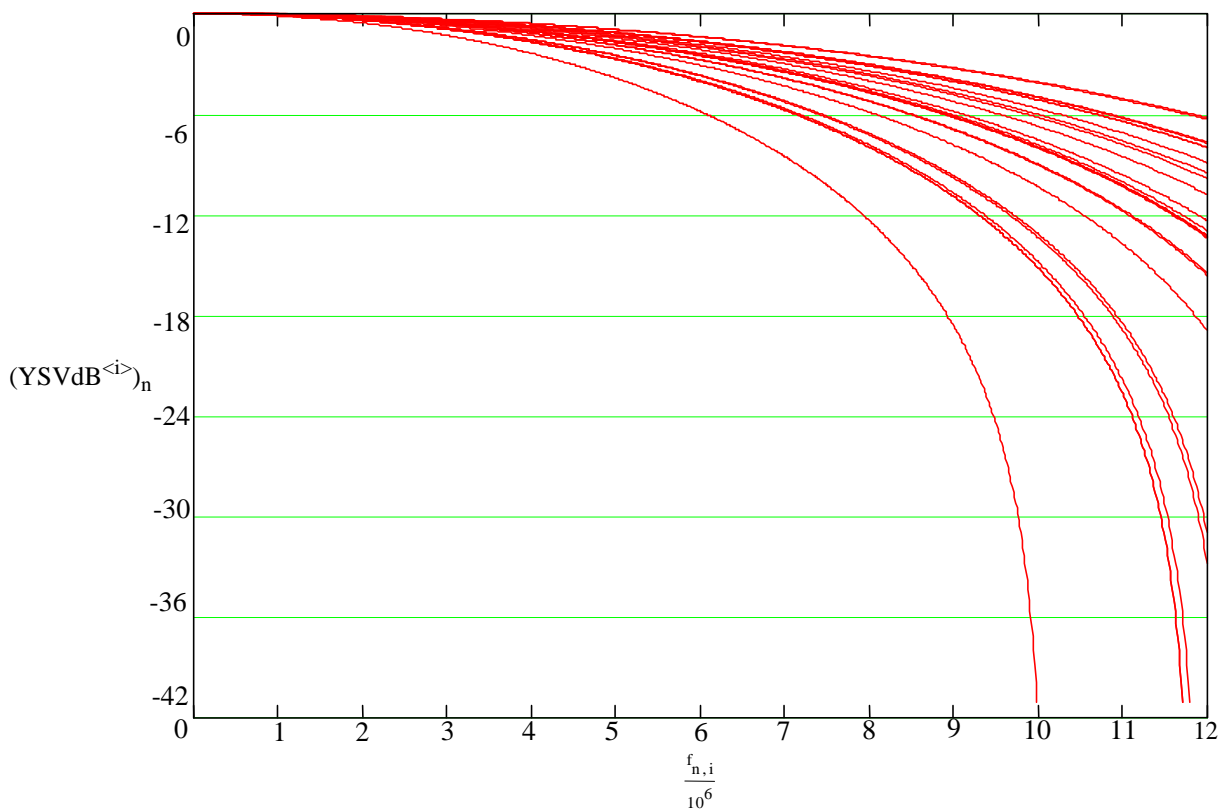

Figure 6: S-Video Luminance Frequency Response (YSV = 1X, YPEAK = 0)

Luminance and Chrominance Filter Options (*continued*)

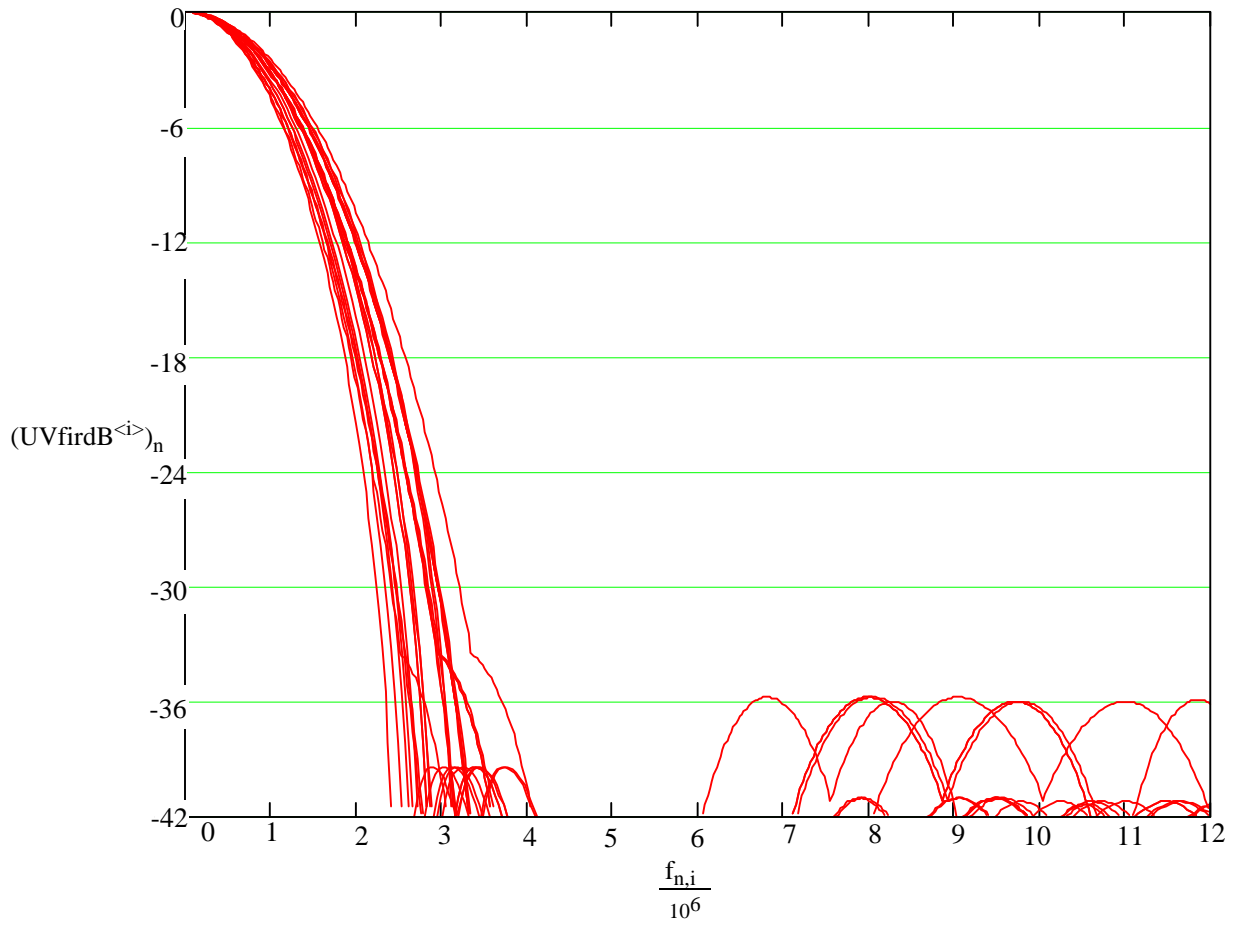

Figure 7: Chrominance Frequency Response

**NTSC and PAL Operation**

Composite and S-Video outputs are supported in either NTSC or PAL format. The general parameters used to characterize these outputs are listed in **Table 10** and shown in **Figure 8**. (See **Figures 11** through **16** for illustrations of composite and S-Video output waveforms).

**CCIR624-3 Compliance**

The CH7008 is predominantly compliant with the recommendations called out in CCIR624-3. The following are the only exceptions to this compliance:

- The frequencies of Fsc, Fh, and Fv can only be guaranteed in master mode, not in slave mode when the graphics device generates these frequencies.
- It is assumed that gamma correction, if required, is performed in the graphics device which establishes the color reference signals.
- All modes provide the exact number of lines called out for NTSC and PAL modes respectively, except mode 21, which outputs 800x600 resolution, scaled by 3:4, to PAL format with a total of 627 lines (vs. 625).
- Chroma signal frequency response will fall within 10% of the exact recommended value.
- Pulse widths and rise/fall times for sync pulses, front/back porches, and equalizing pulses are designed to approximate CCIR624-3 requirements, but will fall into a range of values due to the variety of clock frequencies used to support multiple operating modes.

**Table 10. NTSC/PAL Composite Output Timing Parameters (in mS)**

Symbol	Description	Level (mV)		Duration (uS)	
		NTSC	PAL	NTSC	PAL
<b>A</b>	Front Porch	287	300	1.49 - 1.51	1.48 - 1.51
<b>B</b>	Horizontal Sync	0	0	4.69 - 4.72	4.69 - 4.71
<b>C</b>	Breezeway	287	300	0.59 - 0.61	0.88 - 0.92
<b>D</b>	Color Burst	287	300	2.50 - 2.53	2.24 - 2.26
<b>E</b>	Back Porch	287	300	1.55 - 1.61	2.62 - 2.71
<b>F</b>	Black	340	300	0.00 - 7.50	0.00 - 8.67
<b>G</b>	Active Video	340	300	37.66 - 52.67	34.68 - 52.01
<b>H</b>	Black	340	300	0.00 - 7.50	0.00 - 8.67

For this table and all subsequent figures, key values are:

- Note:**
1. ISET = 360 ohms; V(ISET) = 1.235V; 75 ohms doubly terminated load.
  2. Durations vary slightly in different modes due to the different clock frequencies used.
  3. Active video and black (F, G, H) times vary greatly due to different scaling ratios used in different modes.
  4. Black times (F and H) vary with position controls.



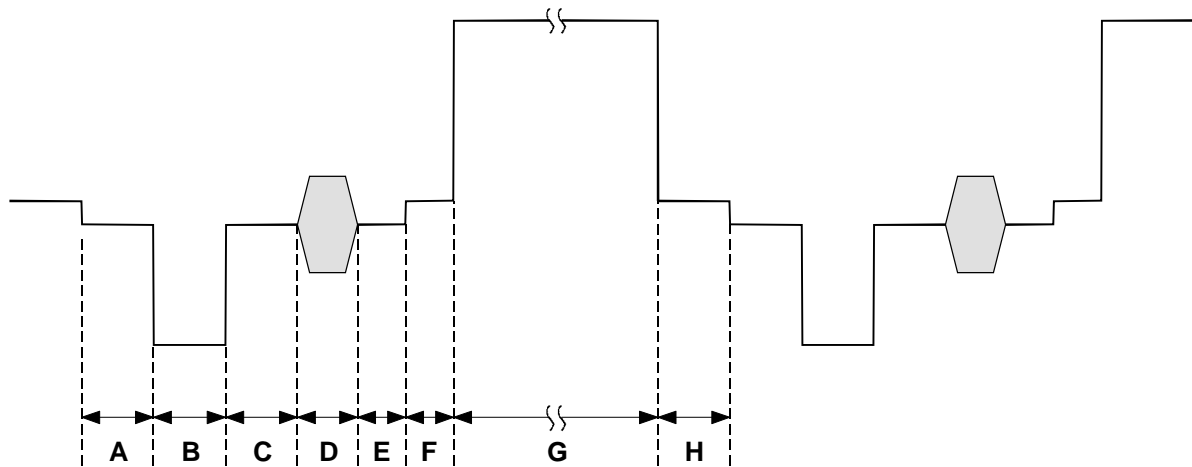

Figure 8: NTSC / PAL Composite Output

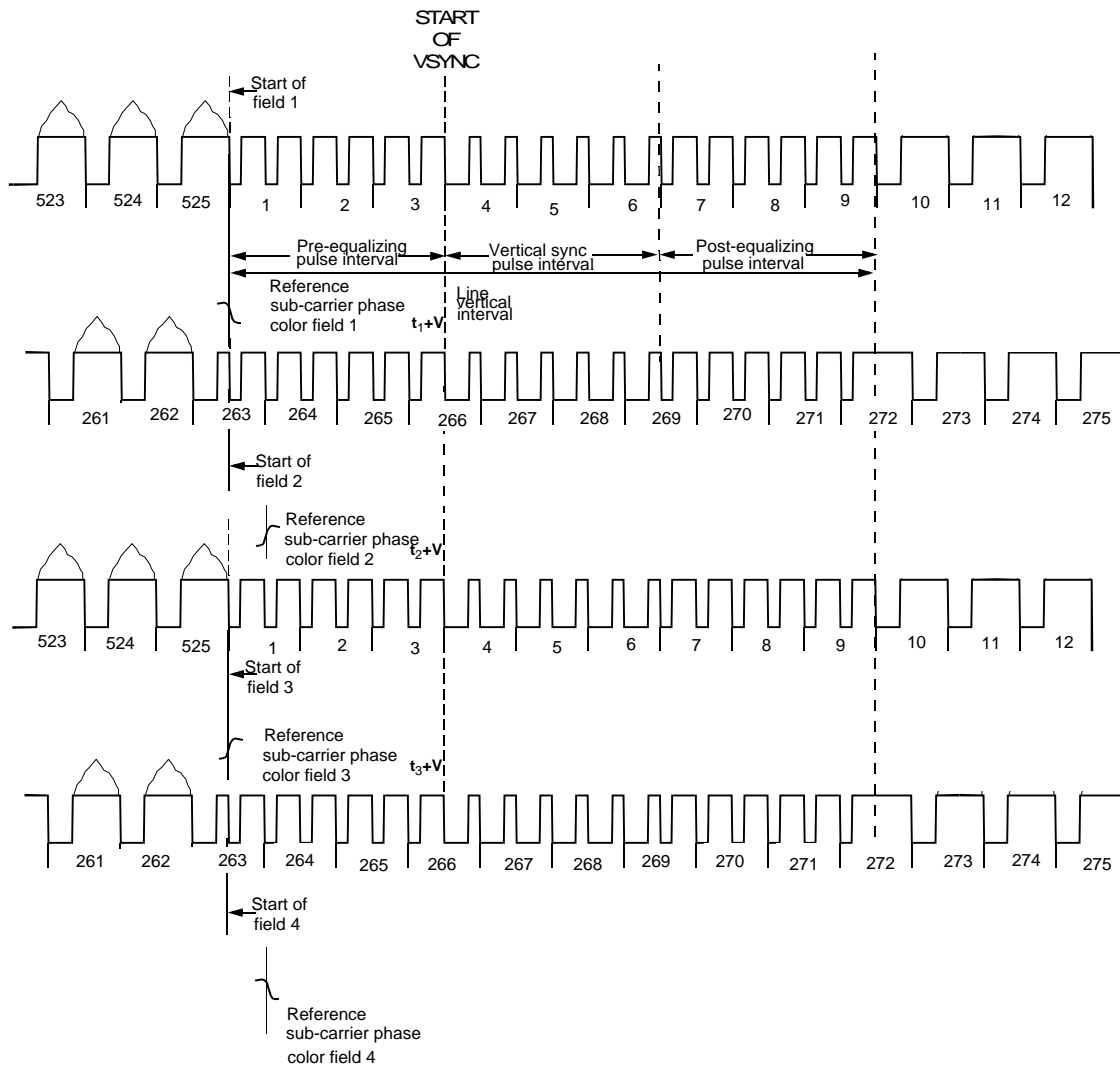

Figure 9: Interlaced NTSC Video Timing

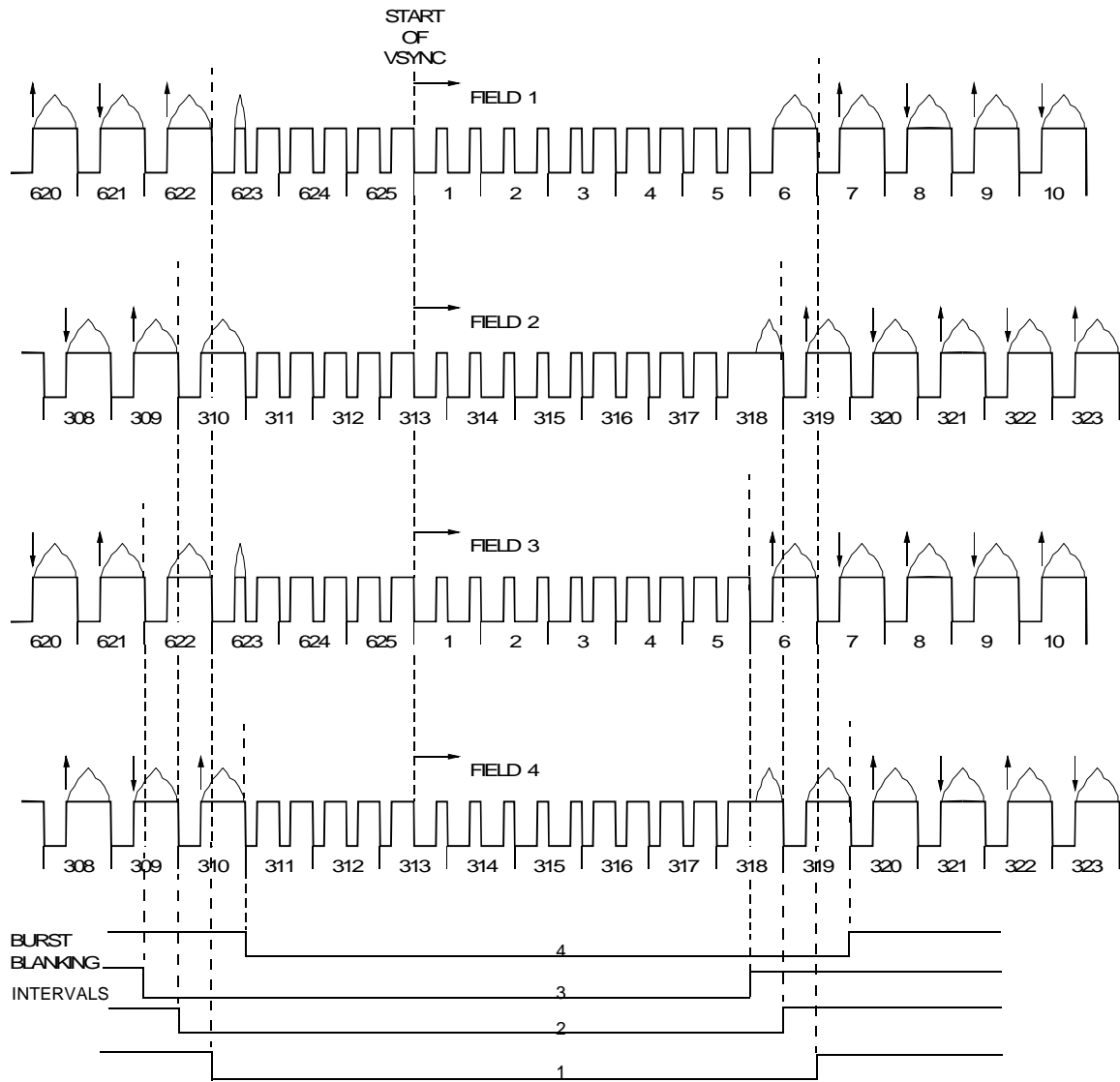

Figure 10: Interlaced PAL Video Timing

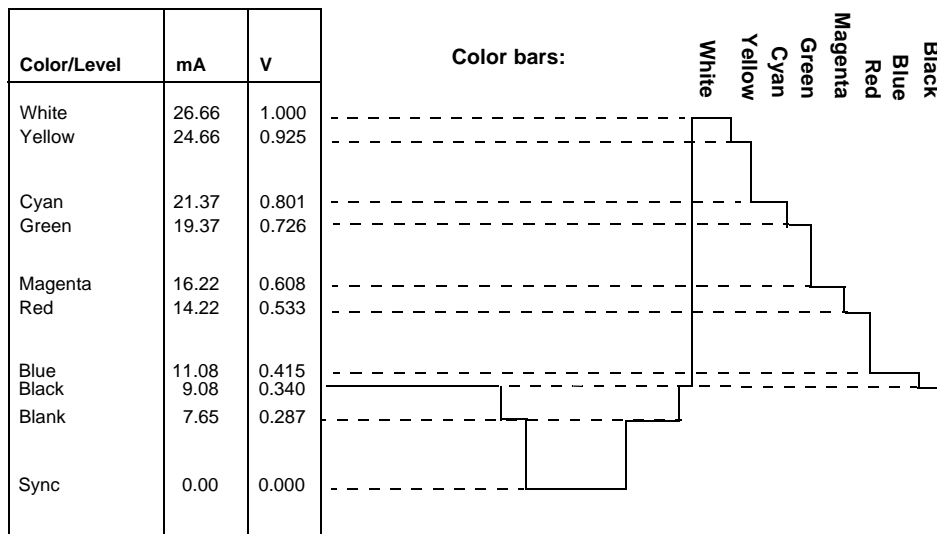

Figure 11: NTSC Y (Luminance) Output Waveform (DACG = 0)

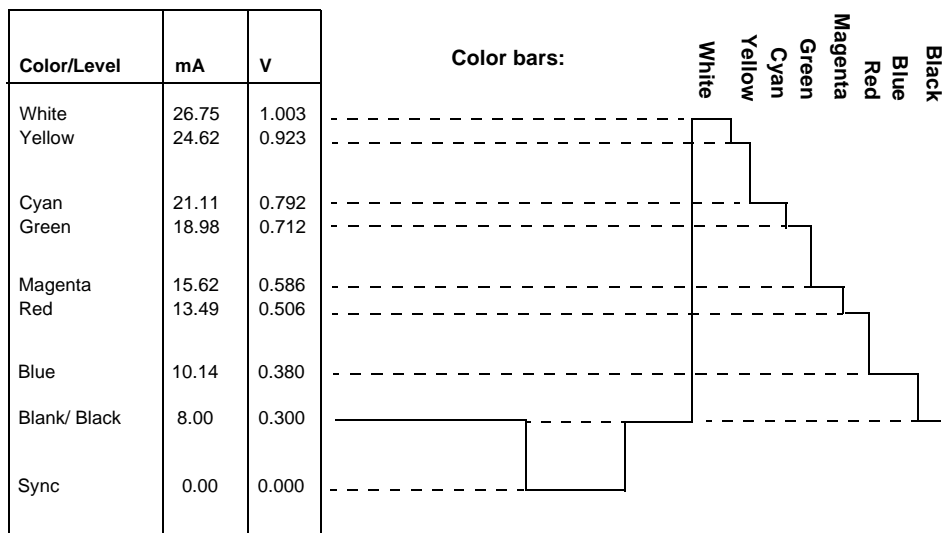

Figure 12: PAL Y (Luminance) Video Output Waveform (DACG = 1)

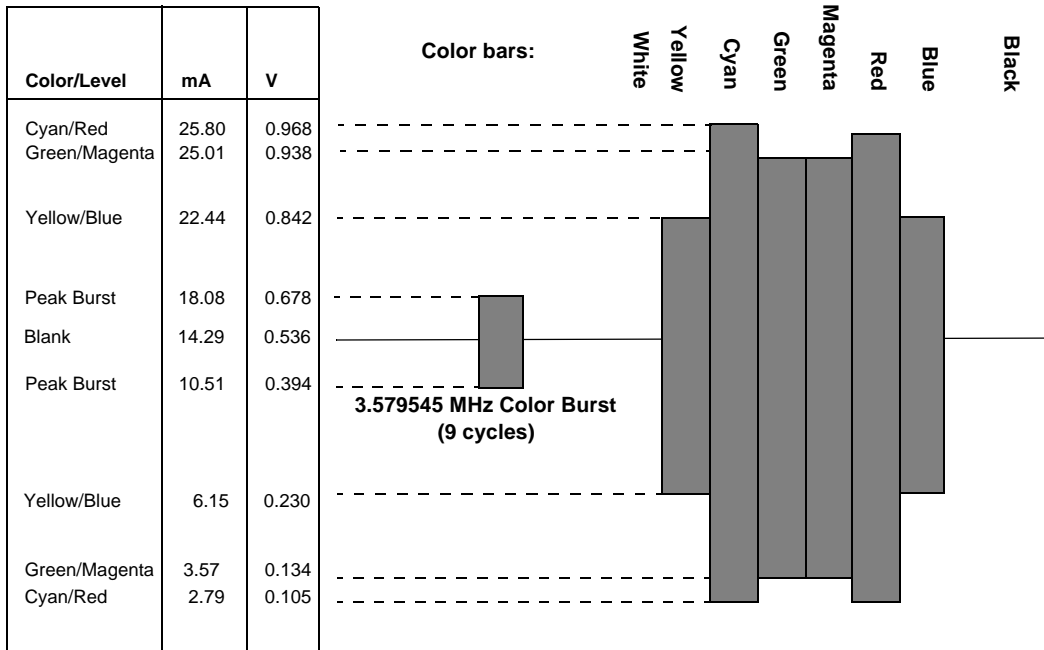

Figure 13: NTSC C (Chrominance) Video Output Waveform (DACG = 0)

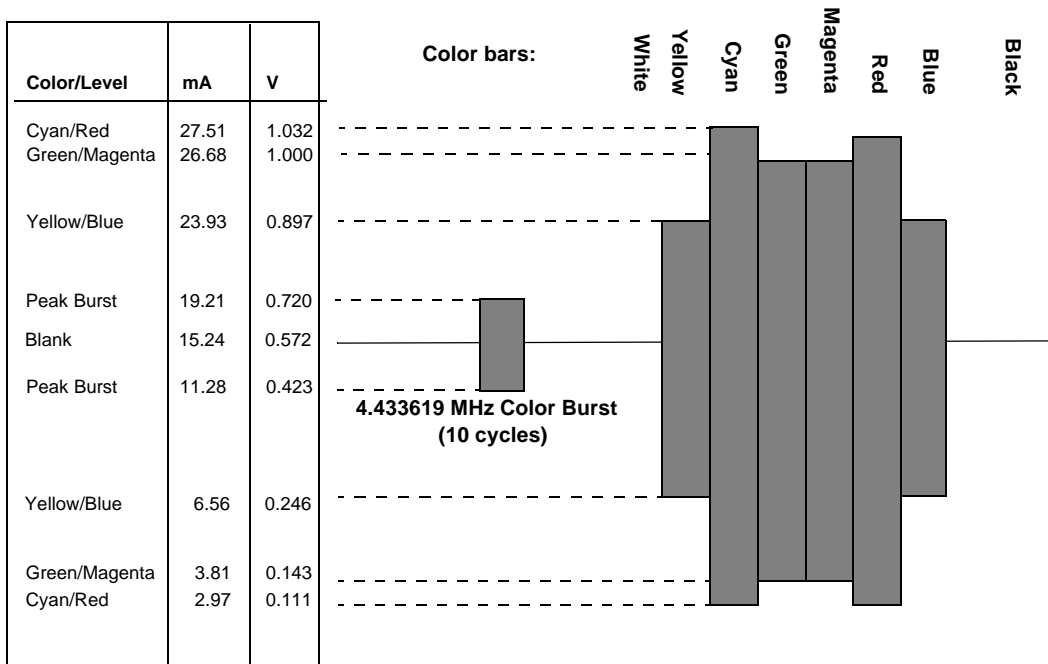

Figure 14: PAL C (Chrominance) Video Output Waveform (DACG = 1)

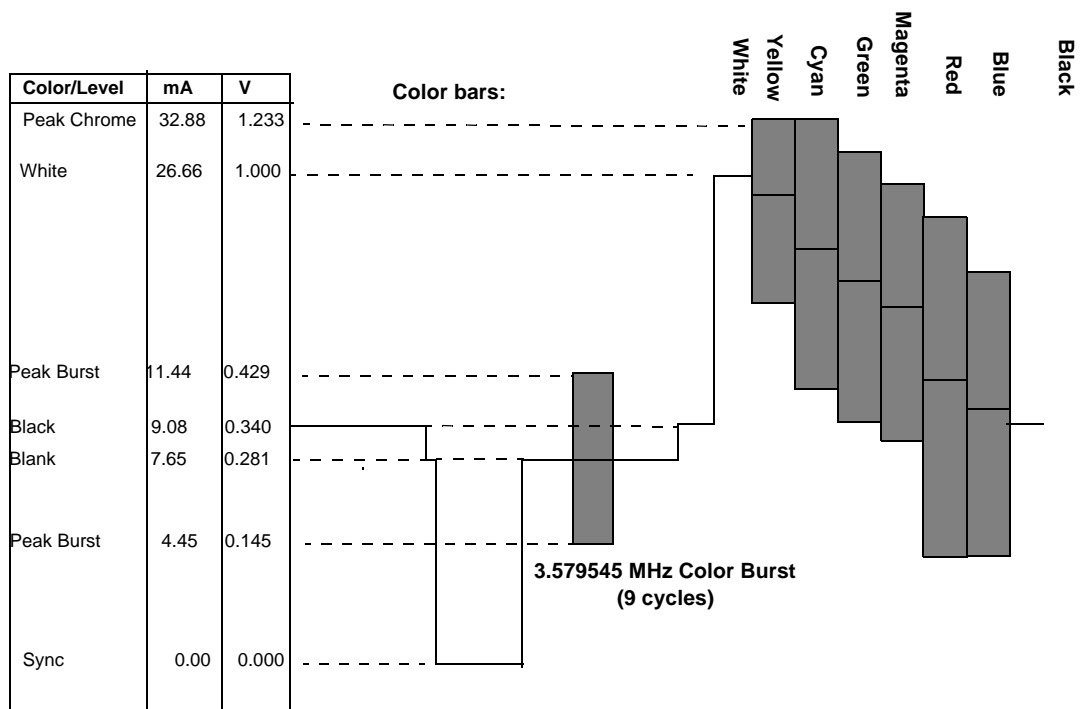

Figure 15: Composite NTSC Video Output Waveform (DACG = 0)

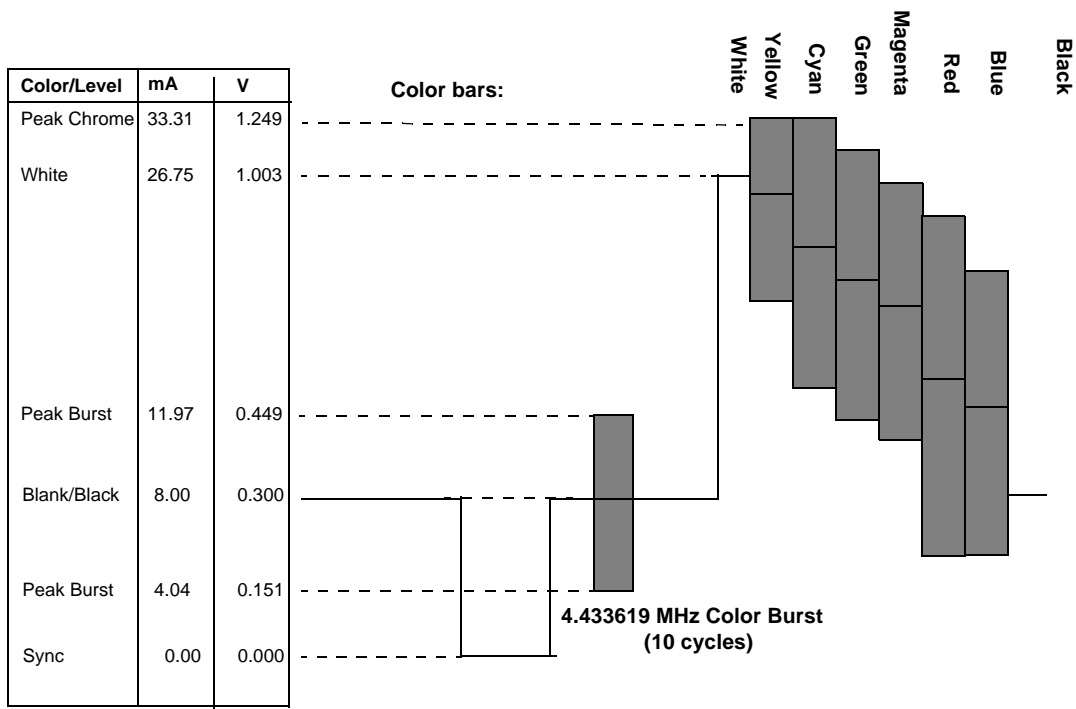
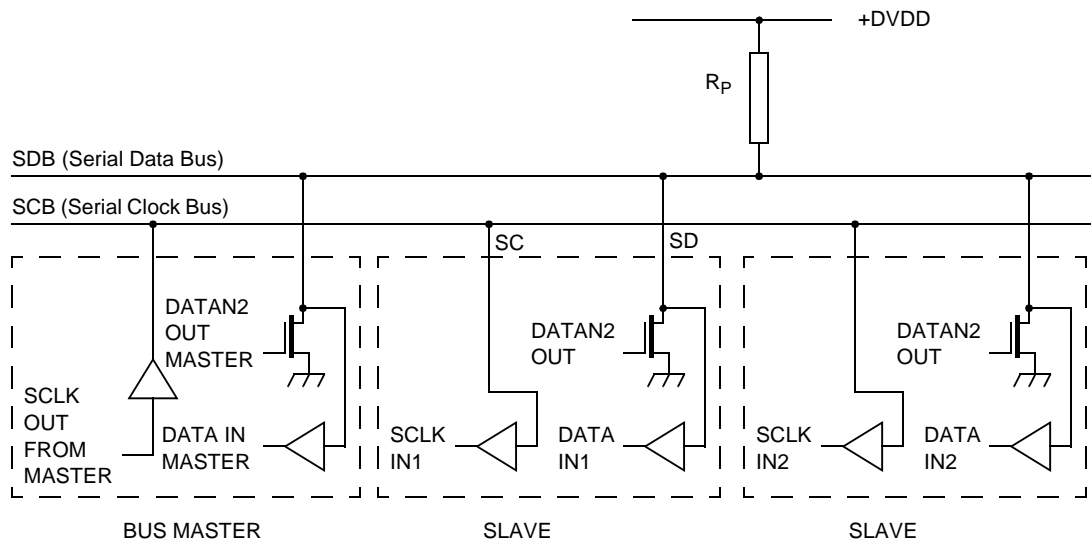

Figure 16: Composite PAL Video Output Waveform (DACG = 1)

## I<sup>2</sup>C Port Operation

The CH7008 contains a standard I<sup>2</sup>C control port, through which the control registers can be written and read. This port is comprised of a two-wire serial interface, pins SD (bidirectional) and SC, which can be connected directly to the SDB and SCB buses as shown in **Figure 17**.

The Serial Clock line (SC) is input only and is driven by the output buffer of the master device (also shown in **Figure 17**). The CH7008 acts as a slave, and generation of clock signals on the bus is always the responsibility of the master device. When the bus is free, both lines are HIGH. The output stages of devices connected to the bus must have an open-drain or open-collector to perform the wired-AND function. Data on the bus can be transferred up to 400 kbit/s.



**Figure 17: Connection of Devices to the Bus**

### Electrical Characteristics for Bus Devices

The electrical specifications of the bus devices' inputs and outputs and the characteristics of the bus lines connected to them are shown in **Figure 17**. A pull-up resistor ( $R_P$ ) must be connected to a  $3.3V \pm 10\%$  supply. The CH7008 is a device with input levels related to DVDD.

#### Maximum and minimum values of pull-up resistor ( $R_P$ )

The value of  $R_P$  depends on the following parameters:

- Supply voltage
- Bus capacitance
- Number of devices connected (input current + leakage current =  $I_{input}$ )

The supply voltage limits the minimum value of resistor  $R_P$  due to the specified minimum sink current of 2mA at  $V_{OL_{max}} = 0.4 V$  for the output stages:

$$R_P \geq (V_{DD} - 0.4) / 2 \quad (R_P \text{ in } k\Omega)$$

The bus capacitance is the total capacitance of wire, connections and pins. This capacitance limits the maximum value of  $R_P$  due to the specified rise time. The equation for  $R_P$  is shown below:

$$R_P \leq 10^3 / C \quad (\text{where: } R_P \text{ is in } k\Omega \text{ and } C, \text{ the total capacitance, is in } pF)$$

The maximum HIGH level input current of each input/output connection has a specified maximum value of  $10 \mu A$ . Due to the desired noise margin of  $0.2V_{DD}$  for the HIGH level, this input current limits the maximum value of  $R_P$ . The  $R_P$  limit depends on  $V_{DD}$  and is shown below:

$$R_P \leq (100 \times V_{DD}) / I_{input} \quad (\text{where: } R_P \text{ is in } k\Omega \text{ and } I_{input} \text{ is in } \mu A)$$

## Transfer Protocol

Both read and write cycles can be executed in “Alternating” and “Auto-increment” modes. Alternating mode expects a register address prior to each read or write from that location (i.e., transfers alternate between address and data). Auto-increment mode allows you to establish the initial register location, then automatically increments the register address after each subsequent data access (i.e., transfers will be address, data...). A basic serial port transfer protocol is shown in **Figure 18** and described below.

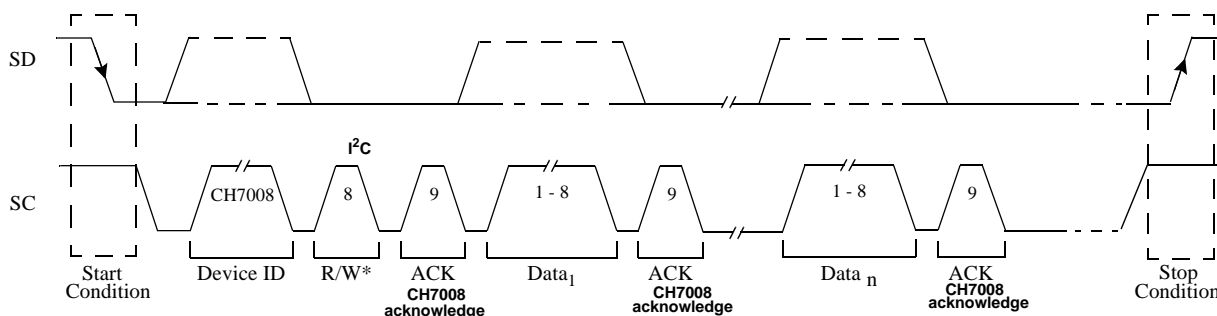

**Figure 18: Serial Port Transfer Protocol**

1. The transfer sequence is initiated when a high-to-low transition of SD occurs while SC is high; this is the “START” condition. Transitions of address and data bits can only occur while SC is low.
2. The transfer sequence is terminated when a low-to-high transition of SD occurs while SC is high; this is the “STOP” condition.
3. Upon receiving the first START condition, the CH7008 expects a Device Address Byte (DAB) from the master device. The value of the device address is shown in the DAB data format below.
4. After the DAB is received, the CH7008 expects a Register Address Byte (RAB) from the master. The format of the RAB is shown in the RAB data format below (note that B7 is not used).

### Device Address Byte (DAB)

B7	B6	B5	B4	B3	B2	B1	B0
1	1	1	0	1	0	1	R/W

#### R/W Read/Write Indicator

“0”: master device will write to the CH7008 at the register location specified by the address AR[5:0]

“1”: master device will read from the CH7008 at the register location specified by the address AR[5:0].

### Register Address Byte (RAB)

B7	B6	B5	B4	B3	B2	B1	B0
1	AutoInc	AR[5]	AR[4]	AR[3]	AR[2]	AR[1]	AR[0]

**Transfer Protocols (continued)**

**AutoInc Register Address Auto-Increment - to facilitate sequential R/W of registers.**

“1”: Auto-Increment enabled (auto-increment mode).

Write: After writing data into a register, the Address Register will automatically be incremented by one.

Read: Before loading data from a register to the on-chip temporary register (getting ready to be serially read), the Address Register will automatically be incremented by one. However, for the first read after an RAB, the Address Register will not be changed.

“0”: Auto-Increment disabled (alternating mode).

Write: After writing data into a register, the Address Register will remain unchanged until a new RAB is written.

Read: Before loading data from a register to the on-chip temporary register (getting ready to be serially read), the Address Register will remain unchanged.

**AR[5:0] Specifies the Address of the Register to be Accessed.**

This register address is loaded into the Address Register of the CH7008. The R/W access, which follows, is directed to the register specified by the content stored in the Address Register.

The following two sections describe the operation of the serial interface for the four combinations of R/W = 0,1 and AutoInc = 0,1.

**CH7008 Write Cycle Protocols (R/W = 0)**

Data transfer with acknowledge is required. The acknowledge-related clock pulse is generated by the master-transmitter. The master-transmitter releases the SD line (HIGH) during the acknowledge clock pulse. The slave-receiver must pull down the SD line, during the acknowledge clock pulse, so that it remains stable LOW during the HIGH period of the clock pulse. The CH7008 always acknowledges for writes (see **Figure 19**). Note that the resultant state on SD is the wired-AND of data outputs from the transmitter and receiver.

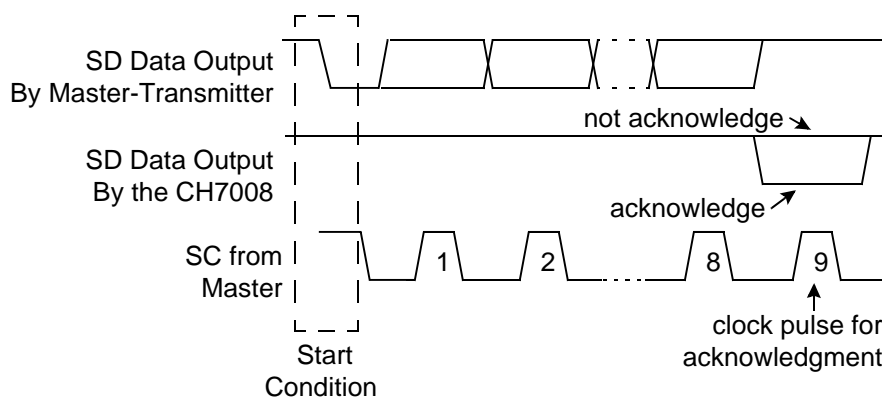

**Figure 19: Acknowledge on the Bus**

**Figure 20** shows two consecutive alternating write cycles for AutoInc = 0 and R/W = 0. The byte of information, following the Register Address Byte (RAB), is the data to be written into the register specified by AR[5:0]. If AutoInc = 0, then another RAB is expected from the master device, followed by another data byte, and so on.



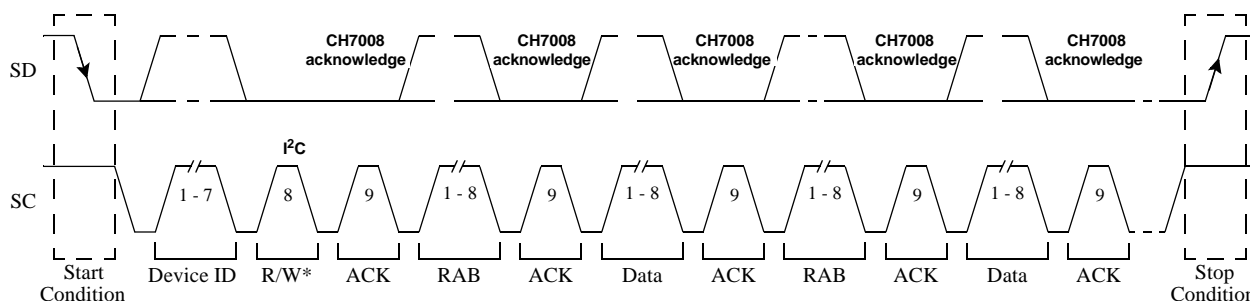

Note: The acknowledge is from the CH7008 (slave).

Figure 20: Alternating Write Cycles

If AutoInc = 1, then the register address pointer will be incremented automatically and subsequent data bytes will be written into successive registers without providing an RAB between each data byte. An Auto-increment write cycle is shown in Figure 21.

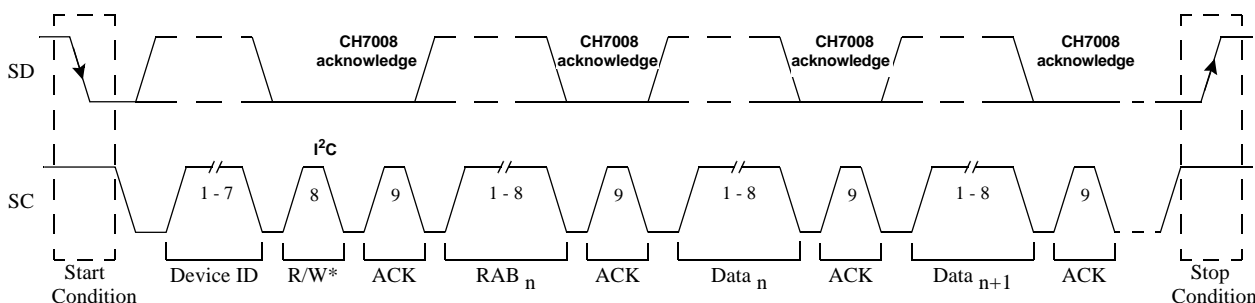

Note: The acknowledge is from the CH7008 (slave).

Figure 21: Auto-Increment Write Cycle

When the auto-increment mode is enabled (AutoInc is set to 1), the register address pointer continues to increment for each write cycle until AR[5:0] = 3F (3F is the address of the Address Register). The next byte of information represents a new auto-sequencing “Starting address”, which is the address of the register to receive the next byte. The auto-sequencing then resumes based on this new “Starting address”. The auto-increment sequence can be terminated any time by either a “STOP” or “RESTART” condition. The write operation can be terminated with a “STOP” condition.

**CH7008 Read Cycle Protocols (R/W = 1)**

If a master-receiver is involved in a transfer, it must signal the end of data to the slave-transmitter by not generating an acknowledge on the last byte that was clocked out of the slave. The slave-transmitter CH7008 releases the data line to allow the master to generate the STOP condition or the RESTART condition.

To read the content of the registers, the master device starts by issuing a “START” condition (or a “RESTART” condition). The first byte of data, after the START condition, is a DAB with R/W = 0. The second byte is the RAB with AR[5:0], containing the address of the register that the master device intends to read from in AR[5:0]. The master device should then issue a “RESTART” condition (“RESTART” = “START”, without a previous “STOP” condition). The first byte of data, after this RESTART condition, is another DAB with R/W=1, indicating the master’s intention to read data hereafter. The master then reads the next byte of data (the content of the register specified in the RAB). If AutoInc = 0, then another RESTART condition, followed by another DAB with R/W = 0 and RAB, is expected from the master device. The master device then issues another RESTART, followed by another DAB. After that, the master may read another data byte, and so on. In summary, a RESTART condition, followed by a DAB, must be produced by the master before each of the RAB, and before each of the data read events. Two consecutive alternating read cycles are shown in Figure 22.

Transfer Protocols (continued)

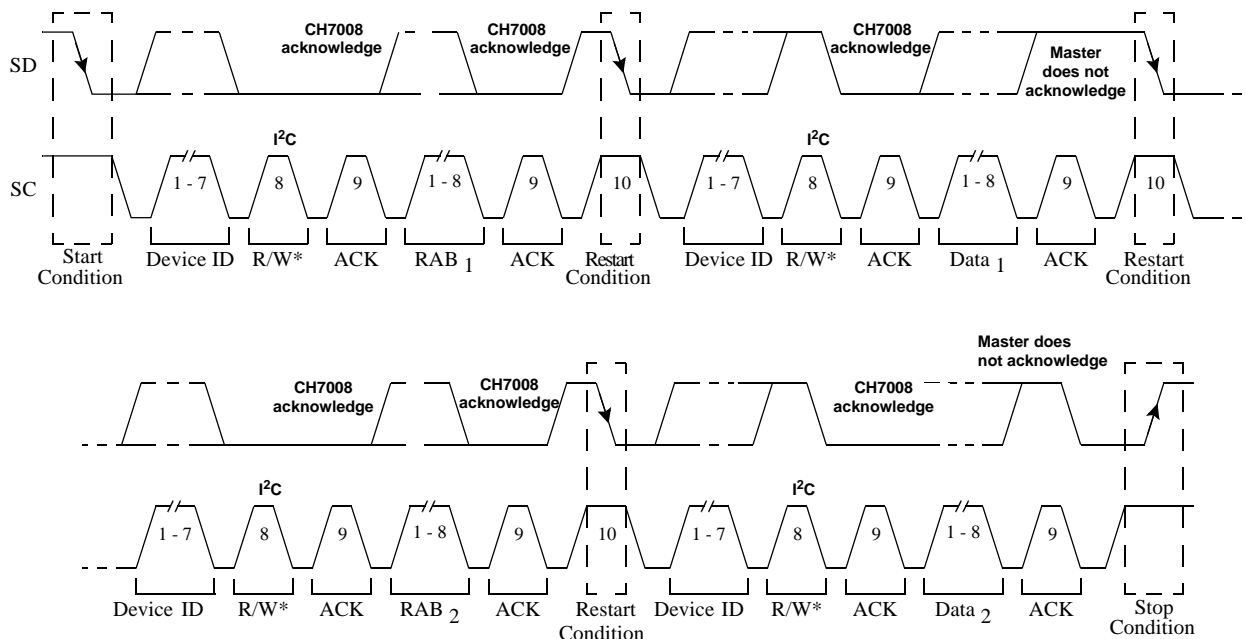

Figure 22: Alternating Read Cycle

If AutoInc = 1, then the address register will be incremented automatically and subsequent data bytes can be read from successive registers, without providing a second RAB.

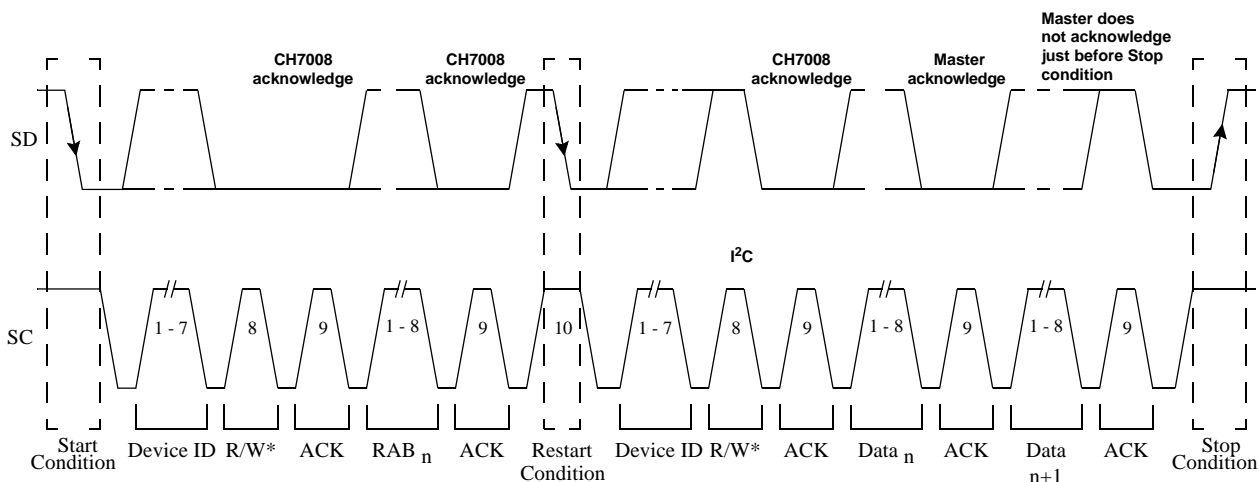

Figure 23: Auto-increment Read Cycle

When the auto-increment mode is enabled (AutoInc is set to 1), the Address Register will continue incrementing for each read cycle. When the content of the Address Register reaches 2A, it will wrap around and start from 00h again. The auto increment sequence can be terminated by either a “STOP” or “RESTART” condition. The read operation can be terminated with a “STOP” condition. **Figure 23** shows an auto-increment read cycle terminated by a STOP or RESTART condition.

## Registers and Programming

The CH7008 is a fully programmable device, providing for full functional control through a set of registers accessed from the I<sup>2</sup>C port. The CH7008 contains a total of 37 registers, which are listed in **Table 11** and described in detail under *Register Descriptions*. Detailed descriptions of operating modes and their effects are contained in the previous section, *Functional Description*. An addition (+) sign in the Bits column below signifies that the parameter contains more than 8 bits, and the remaining bits are located in another register.

**Table 11. Register Map**

Register	Symbol	Address	Bits	Functional Summary
Display Mode	DMR	00H	8	Display mode selection
Flicker Filter	FFR	01H	6	Flicker filter mode selection
Video Bandwidth	VBW	03H	8	Luma and chroma filter bandwidth selection
Input Data Format	IDF	04H	6	Data format and bit-width selections
Clock Mode	CM	06H	8	Sets the clock mode to be used
Start Active Video	SAV	07H	8+	Active video delay setting
Position Overflow	PO	08H	3	MSB bits of position values
Black Level	BLR	09H	8	Black level adjustment input latch clock edge select
Horizontal Position	HPR	0AH	8+	Enables horizontal movement of displayed image on TV
Vertical Position	VPR	0BH	8+	Enables vertical movement of displayed image on TV
Sync Polarity	SPR	0DH	4	Determines the horizontal and vertical sync polarity
Power Management	PMR	0EH	5	Enables power saving modes
Connection Detect	CDR	10H	4	Detection of TV presence
Contrast Enhancement	CE	11H	3	Contrast enhancement setting
PLL M and N extra bits	MNE	13H	5	Contains the MSB bits for the M and N PLL values
PLL-M Value	PLLM	14H	8+	Sets the PLL M value - bits (7:0)
PLL-N Value	PLLN	15H	8+	Sets the PLL N value - bits (7:0)
Buffered Clock	BCO	17H	6	Determines the clock output at pin 41
Subcarrier Frequency Adjust	FSCI	18H -1FH	4 or 8 each	Determines the subcarrier frequency
PLL and Memory Control	PLLC	20H	6	Controls for the PLL and memory sections
CIV Control	CIVC	21H	5	Control of CIV value
Calculated Fsc Increment Value	CIV	21H - 24H	8 each	Readable register containing the calculated subcarrier increment value
Version ID	VID	25H	8	Device version number
Test	TR	26H - 29H	30	Reserved for test (details not included herein)
Address	AR	3FH	6	Current register being addressed

Register Descriptions (continued)

Table 12. I<sup>2</sup>C Alternate Register Map

Register	Bit 7	Bit 6	Bit 5	Bit 4	Bit 3	Bit 2	Bit 1	Bit 0
00H	IR2	IR1	IRO	VOS1	VOS0	SR2	SR1	SR0
01H			FC1	FC0	FY1	FY0	FT1	FT0
02H								
03H	FLFF	CVBW	CBW1	CBW0	YPEAK	YSV1	YSV0	YCV
04H		DACG	Reserved		IDF3	IDF2	IDF1	IDF0
05H								
06H	CFRB	M/S*	Reserved	MCP	XCM1	XCM0	PCM1	PCM0
07H	SAV7	SAV6	SAV5	SAV4	SAV3	SAV2	SAV1	SAV0
08H						SAV8	HP8	VP8
09H	BL7	BL6	BL5	BL4	BL3	BL2	BL1	BL0
0AH	HP7	HP6	HP5	HP4	HP3	HP2	HP1	HP0
0BH	VP7	VP6	VP5	VP4	VP3	VP2	VP1	VP0
0CH								
0DH					DES	SYO	VSP	HSP
0EH				SCART	Reset*	PD2	PD1	PD0
0FH								
10H					YT	CT	CVBST	SENSE
11H						CE2	CE1	CE0
12H								
13H				Reserved	Reserved	N9	N8	M8
14H	M7	M6	M5	M4	M3	M2	M1	M0
15H	N7	N6	N5	N4	N3	N2	N1	N0
16H								
17H			SHF2	SHF1	SHF0	SCO2	SCO1	SCO0
18H					FSCI31	FSCI30	FSCI29	FSCI28
19H					FSCI27	FSCI26	FSCI25	FSCI24
1AH					FSCI23	FSCI22	FSCI21	FSCI20
1BH	GPIOIN1	GPIOIN0	DVDD2	P-OUTP	FSCI19	FSCI18	FSCI17	FSCI16
1CH	GOENB1	GOENB0	DSM	DSEN	FSCI15	FSCI14	FSCI13	FSCI12
1DH					FSCI11	FSCI10	FSCI9	FSCI8
1EH					FSCI7	FSCI6	FSCI5	FSCI4
1FH					FSCI3	FSCI2	FSCI1	FSCI0
20H			PLLCPI	PLLCAP	PLLS	PLL5VD	PLL5VA	MEM5V
21H				CIV25	CIV24	CIVH1	CIVH0	ACIV
22H	CIV23	CIV22	CIV21	CIV20	CIV19	CIV18	CIV17	CIV16
23H	CIV15	CIV14	CIV13	CIV12	CIV11	CIV10	CIV9	CIV8
24H	CIV7	CIV6	CIV5	CIV4	CIV3	CIV2	CIV1	CIVO
25H	VID7	VID6	VID5	VID4	VID3	VID2	VID1	VID0
26H	TS3	TS2	TS1	TS0	RSA	BST	NST	TE
27H			MS2	MS1	MSO	MTD	YLM8	CLM8
28H	YLM7	YLM6	YLM5	YLM4	YLM3	YLM2	YLM1	YLM0
29H	CLM7	CLM6	CLM5	CLM4	CLM3	CLM2	CLM1	CLM0
3FH	Reserved	Reserved	AR5	AR4	AR3	AR2	AR1	AR0

**Register Descriptions (continued)**

**Display Mode Register**

**Address: 00H**

**Bits: 8**

<b>Bit:</b>	<b>7</b>	<b>6</b>	<b>5</b>	<b>4</b>	<b>3</b>	<b>2</b>	<b>1</b>	<b>0</b>
<b>Symbol:</b>	IR2	IR1	IR0	VOS1	VOS0	SR2	SR1	SR0
<b>Type:</b>	R/W	R/W	R/W	R/W	R/W	R/W	R/W	R/W
<b>Default:</b>	0	1	1	0	1	0	1	0

This register provides programmable control of the CH7008 display mode, including input resolution (IR[2:0]), output TV standard (VOS[1:0]), and scaling ratio (SR[2:0]). The mode of operation is determined according to the table below (default is 640x480 input, NTSC output, 7/8's scaling).

**Table 13. Display Modes**

Mode	IR[2:0]	VOS [1:0]	SR [2:0]	Input Data Format (Active Video)	Total Pixels/Line x Total Lines/Frame	Output Format	Scaling	Pixel Clock (MHz)
0	000	00	000	512x384	840x500	PAL	5/4	21.000000
1	000	00	001	512x384	840x625	PAL	1/1	26.250000
2	000	01	000	512x384	800x420	NTSC	5/4	20.139860
3	000	01	001	512x384	784x525	NTSC	1/1	24.671329
4	001	00	000	720x400	1125x500	PAL	5/4	28.125000
5	001	00	001	720x400	1116x625	PAL	1/1	34.875000
6	001	01	000	720x400	945x420	NTSC	5/4	23.790210
7	001	01	001	720x400	936x525	NTSC	1/1	29.454545
8	010	00	010	640x400	1000x500	PAL	5/4	25.000000
9	010	00	001	640x400	1008x625	PAL	1/1	31.500000
10	010	01	000	640x400	840x420	NTSC	5/4	21.146853
11	010	01	001	640x400	840x525	NTSC	1/1	26.433566
12	010	01	010	640x400	840x600	NTSC	7/8	30.209790
13	011	00	000	640x480	840x500	PAL	5/4	21.000000
14	011	00	001	640x480	840x625	PAL	1/1	26.250000
15	011	00	011	640x480	840x750	PAL	5/6	31.500000
16	011	01	001	640x480	784x525	NTSC	1/1	24.671329
17	011	01	010	640x480	784x600	NTSC	7/8	28.195804
18	011	01	011	640x480	800x630	NTSC	5/6	30.209790
19	100	00	001	800x600	944x625	PAL	1/1	29.500000
20	100	00	011	800x600	960x750	PAL	5/6	36.000000
21	100	00	100	800x600	936x836	PAL	3/4	39.000000
22	100	01	011	800x600	1040x630	NTSC	5/6	39.272727
23	100	01	100	800x600	1040x700	NTSC	3/4	43.636364
24	100	01	101	800x600	1064x750	NTSC	7/10	47.832168
25*	101	00	001	720x576	864x625	PAL	1/1	13.500000
26*	101	01	001	720x480	858x525	NTSC	1/1	13.500000

\* Interlaced modes of operation. (For those modes, some functions will be bypassed. For details, please contact the application department.)

**Register Descriptions (continued)**

VOS[1:0]	00	01	10	11
Output Format	PAL	NTSC	PAL-M	NTSC-J

**Flicker Filter Register**

**Symbol: FFR**  
**Address: 01H**  
**Bits: 6**

<b>Bit:</b>	<b>7</b>	<b>6</b>	<b>5</b>	<b>4</b>	<b>3</b>	<b>2</b>	<b>1</b>	<b>0</b>
<b>Symbol:</b>			FC1	FC0	FY1	FY0	FT1	FT0
<b>Type:</b>			R/W	R/W	R/W	R/W	R/W	R/W
<b>Default:</b>			1	1	0	0	1	0

The flicker filter register provides for adjusting the operation of the various filters used in rendering the on-screen image. Adjusting settings between minimal and maximal values enables optimization between sharpness and flicker content. The FC[1:0] bits determine the settings for the chroma channel. The FT[1:0] bits determine the settings for the text enhancement circuit. The FY[1:0] bits determine the settings for the luma channel. In addition, the Chroma channel filtering includes a setting to enable the chroma dot crawl reduction circuit.

**Note:** When writing to register 01H, FY[1:0] is bits 3:2. FT[1:0] is bits 1:0. When reading from the register 01H, FY [1:0] is bits 1:0 and FT[1:0] is bits 3:2.

**Table 14. Flicker Filter Settings**

<b>FY[1:0]</b>	<b>Settings for Luma Channel</b>
00	Minimal Flicker Filtering
01	Slight Flicker Filtering
10	Maximum Flicker Filtering
11	Invalid
<b>FT[1:0]</b>	<b>Settings for Text Enhancement Circuit</b>
00	Maximum Text Enhancement
01	Slight Text Enhancement
10	Minimum Text Enhancement
11	Invalid
<b>FC[1:0]</b>	<b>Settings for Chroma Channel</b>
00	Minimal Flicker Filtering
01	Slight Flicker Filtering
10	Maximum Flicker Filtering
11	Enable Chroma DotCrawl Reduction

**Register Descriptions (continued)**

**Video Bandwidth Register**

**Symbol: VBW**

**Address: 03H**

**Bits: 8**

<b>Bit:</b>	<b>7</b>	<b>6</b>	<b>5</b>	<b>4</b>	<b>3</b>	<b>2</b>	<b>1</b>	<b>0</b>
<b>Symbol:</b>	FLFF	CVBW	CBW1	CBW0	YPEAK	YSV1	YSV0	YCV
<b>Type:</b>	R/W	R/W	R/W	R/W	R/W	R/W	R/W	R/W
<b>Default:</b>	0	0	0	0	0	0	0	0

This register enables the selection of alternative filters for use in the luma and chroma channels. There are currently four filter options defined for the chroma channel, four filter options in the S-Video luma channel and two filter options in the composite luma channel. The **Tables 15** and **16** below show the various settings.

**Table 15. Luma Filter Bandwidth**

<b>YCV</b>	<b>Luma Composite Video Filter Adjust</b>
0	Low bandwidth
1	High bandwidth
<b>YSV[1:0]</b>	<b>Luma S-Video Filter Adjust</b>
00	Low bandwidth
01	Medium bandwidth
10	High bandwidth
11	Reserved
<b>YPEAK</b>	<b>Disables the Y-peaking circuit</b>
0	Disables the peaking filter in luma s-video channel
1	Enables the peaking filter in luma s-video channel

**Table 16. Chroma Filter Bandwidth**

<b>CBW[1:0]</b>	<b>Chroma Filter Adjust</b>
0 0	Low bandwidth
0 1	Medium bandwidth
1 0	Med-high bandwidth
1 1	High bandwidth

Bit 6 (CVBW) outputs the S-Video luma signal on both the S-Video luma output and the CVBS output. A 1 in this location enables the output of a black and white image on composite video, thereby eliminating the degrading effects of the color signal (such as dot crawl or false colors), which is useful for viewing text with high accuracy.

Bit 7 (FLFF) controls the flicker filter used in the 7/10's scaling modes. In these scaling modes, setting FLFF to 1 causes a five line flicker filter to be used. The default setting of 0 uses a four line flicker filter.

Register Descriptions (*continued*)

**Input Data Format Register**

**Symbol: IDF**  
**Address: 04H**  
**Bits: 6**

<b>Bit:</b>	<b>7</b>	<b>6</b>	<b>5</b>	<b>4</b>	<b>3</b>	<b>2</b>	<b>1</b>	<b>0</b>
<b>Symbol:</b>		DACG	Reserved		IDF3	IDF2	IDF1	IDF0
<b>Type:</b>		R/W	R/W		R/W	R/W	R/W	R/W
<b>Default:</b>		0	0		0	0	0	0

This register sets the variables required to define the incoming pixel data stream.

**Table 17. Input Data Format**

IDF[3:0]	Description
0000	Not available
0001	Not available
0010	Not available
0011	Not available
0100	12-bit multiplexed RGB (24-bit color) input (“C” multiplex scheme)
0101	12-bit multiplexed RGB (24-bit color) input (“I” multiplex scheme)
0110	Not available
0111	8-bit multiplexed RGB (16-bit color, 565) input
1000	8-bit multiplexed RGB (15-bit color, 555) input
1001-1111	8-bit multiplexed YCrCb (24-bit color) input (Y, Cr and Cb are multiplexed)

Reserved (bit 5): This bit should be set to 0.

DACG (bit 6): This bit controls the gain of the D/A converters. When DACG=0, the nominal DAC current is 71  $\mu$ A, which provides the correct levels for NTSC and PAL-M. When DACG=1, the nominal DAC current is 76  $\mu$ A, which provides the correct levels for PAL and NTSC-J.

**Clock Mode Register**

**Symbol: CM**  
**Address: 06H**  
**Bits: 8**

<b>Bit:</b>	<b>7</b>	<b>6</b>	<b>5</b>	<b>4</b>	<b>3</b>	<b>2</b>	<b>1</b>	<b>0</b>
<b>Symbol:</b>	CFRB	M/S*	Reserved	MCP	XCM1	XCM0	PCM1	PCM0
<b>Type:</b>	R/W	R/W	R/W	R/W	R/W	R/W	R/W	R/W
<b>Default:</b>	0	0	0	1	0	0	0	0

The setting of the clock mode bits determines the clocking mechanism used in the CH7008. The clock modes are shown in the table below. PCM controls the frequency of the P-OUT clock, and XCM identifies the frequency of the XCLK input clock.



**Register Descriptions (continued)**

**Note:** Although it is possible to set the XCM [1:0] and PCM[1:0] values independent of the input data format, there are only certain combinations of input data format, XCM and PCM, that will result in valid data being demultiplexed at the input of the device. Refer to the “Input Data Format Register” for these combinations.

**Note:** Display modes 25 and 26 must use a 2X multiplexed input data format and a 2X XCLK.

**Table 18. Input Data Format Register**

XCM[1:0]	PCM[1:0]	XCLK	P-Out	Input Data Modes Supported
00	00	1X	1X	4, 5, 7, 8, 9
00	01	1X	2X	4, 5, 7, 8, 9
00	1X	1X	3X	4, 5, 7, 8, 9
01	00	2X	1X	4, 5, 7, 8, 9
01	01	2X	2X	4, 5, 7, 8, 9
01	1X	2X	3X	4, 5, 7, 8, 9

The Clock Mode Register also contains the following bits:

- MCP (bit 4) determines which edge of the pixel clock output will be used to latch input data. Zero selects the negative edge, one selects the positive edge.
- M/S\* (bit 6) determines whether the device operates in master or slave clock mode. In master mode (1), the 14.31818MHz clock is used as a frequency reference to the PLL. In slave mode (0) the XCLK input is used as a reference to the PLL, and is divided by the value specified by XCM[1:0]. The divide by N and M are forced to one.
- CFRB (bit 7) sets whether the chroma subcarrier free-runs, or is locked to the video signal. One causes the subcarrier to lock to the TV vertical rate, and should be used when the ACIV bit is set to zero. Zero causes the subcarrier to free-run, and should be used when the ACIV bit is set to one.

**Start Active Video Register**

**Symbol: SAV**  
**Address: 07H**  
**Bits: 8**

Bit:	7	6	5	4	3	2	1	0
<b>Symbol:</b>	SAV7	SAV6	SAV5	SAV4	SAV3	SAV2	SAV1	SAV0
<b>Type:</b>	R/W	R/W	R/W	R/W	R/W	R/W	R/W	R/W
<b>Default:</b>	0	0	0	0	0	0	0	0

This register sets the delay in pixel increments from leading edge of horizontal sync, or the rising edge of data start, to the start of active video. The entire bit field SAV[8:0] is comprised of this register SAV[7:0], plus the MSB value contained in the position overflow register, bit SAV8. This is decoded as a whole number of pixels, which can be set anywhere between 0 and 511 pixels. Therefore, in any 2X clock mode, the number of 2X clocks from the leading edge of sync to the first active data must be a multiple of two clocks. In any 3X clock mode, the number of 3X clocks from the leading edge of sync to the first active data must be a multiple of three clocks. When using the DS/BCO pin as a data start input, this register should be set to decimal value 11.

**Register Descriptions (continued)**

**Position Overflow Register**

**Symbol: PO**  
**Address: 08H**  
**Bits: 3**

<b>Bit:</b>	<b>7</b>	<b>6</b>	<b>5</b>	<b>4</b>	<b>3</b>	<b>2</b>	<b>1</b>	<b>0</b>
<b>Symbol:</b>						SAV8	HP8	VP8
<b>Type:</b>						R/W	R/W	R/W
<b>Default:</b>						0	0	0

This position overflow register contains the MSB values for the SAV, HP and VP values, as follows:

- VP8 (bit 0) is the MSB of the vertical position value (see explanation under “Vertical Position Register”).
- HP8 (bit 1) is the MSB of the horizontal position value (see explanation under “Horizontal Position Register”).
- SAV8 (bit 2) is the MSB of the start of active video value (see explanation under “Start Active Video Register”).

**Black Level Register**

**Symbol: BLR**  
**Address: 09H**  
**Bits: 8**

<b>Bit:</b>	<b>7</b>	<b>6</b>	<b>5</b>	<b>4</b>	<b>3</b>	<b>2</b>	<b>1</b>	<b>0</b>
<b>Symbol:</b>	BL7	BL6	BL5	BL4	BL3	BL2	BL1	BL0
<b>Type:</b>	R/W	R/W	R/W	R/W	R/W	R/W	R/W	R/W
<b>Default:</b>	0	1	1	1	1	1	1	1

This register sets the black level. The luminance data is added to this black level, which must be set between 90 and 208, with the default value being 127. Recommended values for NTSC and PAL-M are 127, 105 for PAL and 100 for NTSC-J.

**Horizontal Position Register**

**Symbol: HPR**  
**Address: 0AH**  
**Bits: 8**

<b>Bit:</b>	<b>7</b>	<b>6</b>	<b>5</b>	<b>4</b>	<b>3</b>	<b>2</b>	<b>1</b>	<b>0</b>
<b>Symbol:</b>	HP7	HP6	HP5	HP4	HP3	HP2	HP1	HP0
<b>Type:</b>	R/W	R/W	R/W	R/W	R/W	R/W	R/W	R/W
<b>Default:</b>	0	0	0	0	0	0	0	0

The horizontal position register is used to shift the displayed TV image in a horizontal direction (left or right) to achieve a horizontally centered image on screen. The entire bit field, HP[8:0] is comprised of this register HP[7:0] plus the MSB value contained in the position overflow register, bit HP8. Increasing this value moves the displayed image position RIGHT; decreasing this value moves the displayed image position LEFT. Each increment moves the image position by 4 input pixels.

**Register Descriptions (continued)**

**Vertical Position Register**

**Symbol: VPR**  
**Address: 0BH**  
**Bits: 8**

<b>Bit:</b>	<b>7</b>	<b>6</b>	<b>5</b>	<b>4</b>	<b>3</b>	<b>2</b>	<b>1</b>	<b>0</b>
<b>Symbol:</b>	VP7	VP6	VP5	VP4	VP3	VP2	VP1	VP0
<b>Type:</b>	R/W	R/W	R/W	R/W	R/W	R/W	R/W	R/W
<b>Default:</b>	0	0	0	0	0	0	0	0

This register is used to shift the displayed TV image in a vertical direction (up or down) to achieve a vertically centered image on screen. This bit field, VP[8:0] represents the TV line number (relative to the VGA vertical sync) used to initiate the generation and insertion of the TV vertical interval (i.e., the first sequence of equalizing pulses). Increasing values delay the output of the TV vertical sync, causing the image position to move UP on the TV screen. Decreasing values, therefore, move the image position DOWN. Each increment moves the image position by one TV lines (approximately 4 input lines). The maximum value that should be programmed into the VP[8:0] value is the number of TV lines minus one, divided by two (262, 312 or 313). When panning the image up, the number should be increased until (TVLPF-1) /2 is reached; the next step should be to reset the register to zero. When panning the image down the screen, the VP[8:0] value should be decremented until the value zero is reached. The next step should set the register to (TVLPF-1) /2, and then decrementing can continue. If this value is programmed to a number greater than (TV lines per frame-1) /2, a TV vertical SYNC will not be generated.

**Sync Polarity Register**

**Symbol: SPR**  
**Address: 0DH**  
**Bits: 4**

<b>Bit:</b>	<b>7</b>	<b>6</b>	<b>5</b>	<b>4</b>	<b>3</b>	<b>2</b>	<b>1</b>	<b>0</b>
<b>Symbol:</b>					DES	SYO	VSP	HSP
<b>Type:</b>					R/W	R/W	R/W	R/W
<b>Default:</b>					0	0	0	0

This register provides selection of the synchronization signal input to, or output from, the CH7008.

- HSP (bit 0) is Horizontal Sync Polarity - an HSP value of zero means the horizontal sync is active low and a value of one means the horizontal sync is active high.
- VSP (bit 1) is Vertical Sync Polarity - a VSP value of zero means the vertical sync is active low and a value of one means the vertical sync is active high.
- SYO (bit 2) is Sync Direction - a SYO value of zero means that H and V sync are input to the CH7008. A value of one means that H and V sync are output from the CH7008.
- DES (bit 3) is Detect Embedded Sync - a DES value of zero means that H and V sync will be obtained from the direct pin inputs. A DES value of one means that H and V sync will be detected from the embedded codes on the pixel input stream. Note that this will only be valid for the YCrCb input modes.

**Note:** When sync direction is set to be an output, horizontal sync will use a fixed pulse width of 64 pixels and vertical sync will use a fixed pulse width of 1 line.

**Register Descriptions (continued)**

**Power Management Register**

**Symbol: PMR**  
**Address: 0EH**  
**Bits: 5**

<b>Bit:</b>	<b>7</b>	<b>6</b>	<b>5</b>	<b>4</b>	<b>3</b>	<b>2</b>	<b>1</b>	<b>0</b>
<b>Symbol:</b>				SCART	Reset*	PD2	PD1	PD0
<b>Type:</b>				R/W	R/W	R/W	R/W	R/W
<b>Default:</b>				0	1	1	0	1

This register provides control of the power management functions, a software reset (Reset\*) and the SCART output enable. The CH7008 provides programmable control of its operating states, as described in the table below.

**Table 19. Power Management**

<b>PD[2:0]</b>	<b>Operating State</b>	<b>Functional Description</b>
000	Composite Off	CVBS DAC is powered down.
001	Power Down	Most pins and circuitry are disabled (except for the buffered clock outputs which are limited to the 14MHz output and VCO divided outputs).
010	S-Video Off	S-Video DACs are powered down.
011	Normal (On)	All circuits and pins are active.
1XX	Full Power Down	All circuitry is powered down except I <sup>2</sup> C circuit.

Reset\* (bit 3) is soft reset. Setting this bit will reset all circuitry requiring a power on reset, except for this bit itself and the I<sup>2</sup>C state machines.

SCART (bit 4) is the SCART enable. Setting SCART = 0 means the CH7008 will operate normally, outputting Y/C and CVBS from the three DACs. SCART=1 enables SCART output, which will cause R, G and B to be output from the DACs and composite sync from the CSYNC pin.

**Note:** For complete details regarding the operation of these modes, see the *Power Management* in *Functional Description* sections.

**Connection Detect Register**

**Symbol: CDR**  
**Address: 10H**  
**Bits: 4**

<b>Bit:</b>	<b>7</b>	<b>6</b>	<b>5</b>	<b>4</b>	<b>3</b>	<b>2</b>	<b>1</b>	<b>0</b>
<b>Symbol:</b>					YT	CT	CVBST	SENSE
<b>Type:</b>					R	R	R	W
<b>Default:</b>					0	0	0	0

The Connection Detect Register provides a means to sense the connection of a TV to either S-Video or Composite video outputs. The status bits, YT, CT, and CVBST correspond to the DAC outputs for S-Video (Y and C outputs) and Composite video (CVBS), respectively. However, the values contained in these status bits are NOT VALID until a sensing procedure is performed. Use of this register requires a sequence of events to enable the sensing of outputs, then reading out the applicable status bits. The detection sequence works as follows:

1. Ensure the power management register bits 2-0 are set to 011 (normal mode).

**Register Descriptions (continued)**

2. Ensure that the XCLK and XCLK\* input pins are receiving clock signals (alternatively, XCLK\* can be connected to the VREF pin).
3. Set the SENSE bit to a 1. This forces a constant current output onto the Y, C, and CVBS outputs. Note that during SENSE = 1, these 3 analog outputs are at steady state and no TV synchronization pulses are asserted.
4. Reset the SENSE bit to 0. This triggers a comparison between the voltage sensed on these analog outputs and the reference value expected ( $V_{\text{threshold}} = 1.235\text{V}$ ). If the measured voltage is below this threshold value, it is considered connected, if it is above this voltage it is considered unconnected. During this step, each of the three status bits corresponding to individual analog outputs will be set if they are NOT connected.
5. Read the status bits. The status bits Y, C and CVBST (corresponding to S-Video Y and C outputs and composite video) now contain valid information which can be read to determine which outputs are connected to a TV. Again, a “0” indicates a valid connection, a “1” indicates an unconnected output.

**Contrast Enhancement Register**

**Symbol: CE**

**Address: 11H**

**Bits: 3**

Bit:	7	6	5	4	3	2	1	0
Symbol:						CE2	CE1	CE0
Type:						R/W	R/W	R/W
Default:						0	1	1

This register provides control of the contrast enhancement feature of the CH7008, according to the table below. At a setting of 000, the video signal will be pulled towards the maximum black level. As the value of CE[2:0] is increased, the amount that the signal is pulled towards black is decreased until unity gain is reached at a setting of 011. From this point on, the video signal is pulled towards the white direction, with the effect increasing with increasing settings of CE[2:0].

**Table 20. Contrast Enhancement Function**

CE[2:0]	Description (all gains limited to 0-255)
000	Contrast enhancement gain 3 $Y_{\text{out}} = (5/4)*(Y_{\text{in}}-102) = \text{Enhances Black}$
001	Contrast enhancement gain 2 $Y_{\text{out}} = (9/8)*(Y_{\text{in}}-57)$
010	Contrast enhancement gain 1 $Y_{\text{out}} = (17/16)*(Y_{\text{in}}-30)$
011	Normal mode $Y_{\text{out}} = (1/1)*(Y_{\text{in}}-0) = \text{Normal Contrast}$
100	Contrast enhancement gain 1 $Y_{\text{out}} = (17/16)*(Y_{\text{in}}-0)$
101	Contrast enhancement gain 2 $Y_{\text{out}} = (9/8)*(Y_{\text{in}}-0)$
110	Contrast enhancement gain 3 $Y_{\text{out}} = (5/4)*(Y_{\text{in}}-0)$
111	Contrast enhancement gain 4 $Y_{\text{out}} = (3/2)*(Y_{\text{in}}-0) = \text{Enhances White}$

Register Descriptions (continued)

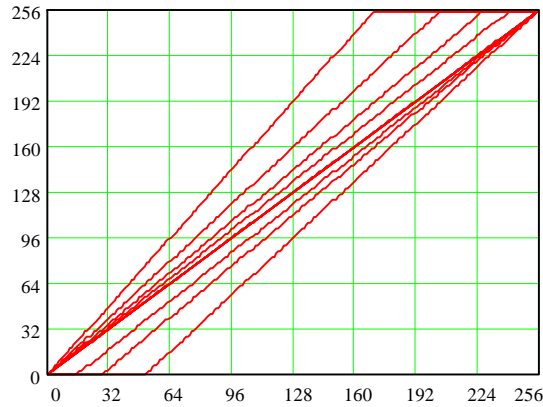

Figure 24: Luma Transfer Function at different contrast enhancement settings.

PLL Overflow Register

Symbol: MNE  
 Address: 13H  
 Bits: 5

Bit:	7	6	5	4	3	2	1	0
Symbol:				Reserved	Reserved	N9	N8	M8
Type:				R/W	R/W	R/W	R/W	R/W
Default:				0	0	0	0	0

The PLL Overflow Register contains the MSB bits for the 'M' and 'N' values, which will be described in the PLL-M and PLL-N registers, respectively. The reserved bits should not be written to.

PLL M Value Register

Symbol: PLLM  
 Address: 14H  
 Bits: 8

Bit:	7	6	5	4	3	2	1	0
Symbol:	M7	M6	M5	M4	M3	M2	M1	M0
Type:	R/W	R/W	R/W	R/W	R/W	R/W	R/W	R/W
Default:	0	1	0	0	0	0	0	1

The PLL M value register determines the division factor applied to the frequency reference clock before it is input to the PLL phase detector when the CH7008 is operating in master mode. In slave mode, an external pixel clock is used instead of the frequency reference, and the division factor is determined by the XCM[3:0] value. This register contains the lower 8 bits of the complete 9-bit M value.

**Register Descriptions (continued)**

**PLL N Value Register**

**Symbol: PLLN**  
**Address: 15H**  
**Bits: 8**

<b>Bit:</b>	<b>7</b>	<b>6</b>	<b>5</b>	<b>4</b>	<b>3</b>	<b>2</b>	<b>1</b>	<b>0</b>
<b>Symbol:</b>	N7	N6	N5	N4	N3	N2	N1	N0
<b>Type:</b>	R/W	R/W	R/W	R/W	R/W	R/W	R/W	R/W
<b>Default:</b>	1	0	0	0	0	0	0	0

The PLL N value register determines the division factor applied to the VCO output before being applied to the PLL phase detector, when the CH7008 is operating in master mode. In slave mode, the value of 'N' is always 1. This register contains the lower 8 bits of the complete 10-bit N value. The pixel clock generated in a master mode and is calculated according to the equation below:

$$F_{\text{pixel}} = F_{\text{ref}} * [(N+2) / (M+2)]$$

When using a 14.318 MHz frequency reference, the required M and N values for each mode are shown in the table below

**Table 21. M and N Values for Each Mode**

Mode	VGA Resolution, TV Standard, Scaling Ratio	N 10-bits	M 9-bits	Mode	VGA Resolution, TV Standard, Scaling Ratio	N 10-bits	M 9-bits
0	512x384, PAL, 5:4	20	13	14	640x480, PAL, 1:1	9	4
1	512x384, PAL, 1:1	9	4	15	640x480, PAL, 5:6	9	3
2	512x384, NTSC, 5:4	126	89	16	640x480, NTSC, 1:1	110	63
3	512x384, NTSC, 1:1	110	63	17	640x480, NTSC, 7:8	126	63
4	720x400, PAL, 5:4	53	26	18	640x480, NTSC, 5:6	190	89
5	720x400, PAL, 1:1	339	138	19	800x600, PAL, 1:1	647	313
6	720x400, NTSC, 5:4	106	63	20	800x600, PAL, 5:6	86	33
7	720x400, NTSC, 1:1	70	33	21	800x600, PAL, 3:4	284	103
8	640x400, PAL, 5:4	108	61	22	800x600, NTSC, 5:6	94	33
9	640x400, PAL, 1:1	9	3	23	800x600, NTSC, 3:4	62	19
10	640x400, NTSC, 5:4	94	63	24	800x600, NTSC, 7:10	302	89
11	640x400, NTSC, 1:1	22	11	25	720x576, PAL, 1:1	31	33
12	640x400, NTSC, 7:8	190	89	26	720x480, NTSC, 1:1	31	33
13	640x480, PAL, 5:4	20	13				

**Buffered Clock Output Register**

**Symbol: BCO**  
**Address: 17H**  
**Bits: 6**

<b>Bit:</b>	<b>7</b>	<b>6</b>	<b>5</b>	<b>4</b>	<b>3</b>	<b>2</b>	<b>1</b>	<b>0</b>
<b>Symbol:</b>			SHF2	SHF1	SHF0	SCO2	SCO1	SCO0
<b>Type:</b>			R/W	R/W	R/W	R/W	R/W	R/W
<b>Default:</b>			0	0	0	0	0	0

When this pin is selected to be an output, the buffered clock output register determines which clock is selected to be output at the DS/BCO clock output pin and what frequency value is output when a VCO derived signal is output. The tables below show the possible outputs.

**Register Descriptions (continued)**

**Table 22. Clock Output Selection**

SCO[2:0]	Buffered Clock Output
000	14MHz crystal
001	(for test use only)
010	VCO divided by K3 (see <b>Table 23</b> )
011	Field ID signal
100	(for test use only)
101	(for test use only)
110	TV horizontal sync (for test use only)
111	TV vertical sync (for test use only)

**Table 23. K3 Selection**

SHF[2:0]	K3
000	2.5
010	3.5
011	4
100	4.5
101	5
110	6
111	7

**Subcarrier Value Registers**

**Symbol: FSCI**  
**Address: 18H - 1FH**  
**Bits: 4 or 8 each**

Bit:	7	6	5	4	3	2	1	0
<b>Symbol:</b>					FSCI#	FSCI#	FSCI#	FSCI#
<b>Type:</b>					R/W	R/W	R/W	R/W
<b>Default:</b>								

The lower four bits of registers 18H through 1FH contain a 32-bit value which is used as an increment value for the ROM address generation circuitry. The bit locations are specified as the following:

<u>Register</u>	<u>Contents</u>
18H	FSCI[31:28]
19H	FSCI[27:24]
1AH	FSCI[23:20]
1BH	FSCI[19:16]
1CH	FSCI[15:12]
1DH	FSCI[11:8]
1EH	FSCI[7:4]
1FH	FSCI[3:0]



**Register Descriptions (continued)**

When the CH7008 is operating in the master clock mode, the tables below should be used to set the FSCI registers. When using these values, the ACIV bit in register 21H should be set to “0” and the CFRB bit in register 06H should be set to “1”.

**Table 24. FSCI Values (525-Line Modes)**

Mode	NTSC “Normal Dot Crawl”	NTSC “No Dot Crawl”	PAL-M “Normal Dot Crawl”
2	763,363,328	763,366,524	762,524,467
3	623,153,737	623,156,346	622,468,953
6	574,429,782	574,432,187	573,798,541
7	463,962,517	463,964,459	463,452,668
10	646,233,505	646,236,211	645,523,358
11	516,986,804	5165,988,968	516,418,687
12	452,363,454	452,365,347	451,866,351
16	623,153,737	623,156,346	622,468,953
17	545,259,520	545,261,803	544,660,334
18	508,908,885	508,911,016	508,349,645
22	521,957,831	521,960,016	521,384,251
23	469,762,048	469,764,015	469,245,826
24	428,554,851	438,556,645	428,083,911
26	569,408,543	569,410,927	568,782,819

**Table 25. FSCI Values (625-Line Modes)**

Mode	PAL “Normal Dot Crawl”	PAL-N “Normal Dot Crawl”
0	806,021,060	651,209,077
1	644,816,848	520,967,262
4	601,829,058	486,236,111
5	485,346,014	392,125,896
8	677,057,690	547,015,625
9	537,347,373	434,139,385
13	806,021,060	651,209,077
14	644,816,848	520,967,262
15	537,347,373	434,139,385
19	645,499,916	521,519,134
20	528,951,320	427,355,957
21	488,262,757*	394,482,422
25	705,268,427	569,807,942

When the CH7008 is operating in the slave clock mode, the ACIV bit in register 21H should be set to “1” and the CFRB bit in register 06H should be set to “0”.

**\*Note:** For reduced cross-color and cross-luminance artifacts, a value of 488,265,597 can be used with CFRB = “0” & ACIV = “0”.

**Register Descriptions (*continued*)**

**Symbol:**  
**Address: 1BH**  
**Bits: 8**

<b>Bit:</b>	<b>7</b>	<b>6</b>	<b>5</b>	<b>4</b>	<b>3</b>	<b>2</b>	<b>1</b>	<b>0</b>
<b>Symbol:</b>	GPIOIN1	GPIOIN0	DVDD2	P-OUTP	FSCI19	FSCI18	FSCI17	FSCI16
<b>Type:</b>	R/W	R/W	R/W	R/W	R/W	R/W	R/W	R/W
<b>Default:</b>	0	0	0	0	0	0	0	0

Register 1BH, bit 4 (P-OUTP) controls the polarity of the P-OUT pin.

Register 1BH, bit 5 controls the P-OUT drive level, and should be set to 0 when DVDD2 is 1.8V, and set to 1 when DVDD2 is 3.3V.

Register 1BH, bits 7 and 6 control the GPIO pins. When the corresponding GOENB bits are low, these registers values are driven out of the GPIO pins. When the corresponding GOENB bits are high, these registers values can be read to determine the level forced into the GPIO pins.

**Symbol:**  
**Address: 1CH**  
**Bits: 6**

<b>Bit:</b>	<b>7</b>	<b>6</b>	<b>5</b>	<b>4</b>	<b>3</b>	<b>2</b>	<b>1</b>	<b>0</b>
<b>Symbol:</b>	GOENB1	GOENB0	DSM	DSEN	FSCI15	FSCI14	FSCI13	FSCI12
<b>Type:</b>	R/W	R/W	R/W	R/W	R/W	R/W	R/W	R/W
<b>Default:</b>	1	1	1	1	0	0	0	0

Register 1CH, bit 4 controls whether the Data Start pin or the Horizontal Sync pin is used to determine the start of active video. When this bit is low, the pin continues to operate as the BCO pin described in the BCO register section. When this bit is high the pin becomes an input for the Data Start signal. A value of 0 is recommended.

Register 1CH, bit 5 determines how the Data Start input is used. A value of 1 is recommended.

Register 1CH, bits 7 and 6 control the GPIO pins direction. When a GOENB bit is low, the corresponding GPIO pin is an output pin. When a GOENB bit is high, the corresponding GPIO pin can be read to determine the level forced into it.

**Register Descriptions (continued)**

**PLL Control Register**

**Symbol: PLLC**

**Address: 20H**

**Bits: 6**

Bit:	7	6	5	4	3	2	1	0
Symbol:			PLLCPI	PLLCAP	PLLS	PLL5VD	PLL5VA	MEM5V
Type:			R/W	R/W	R/W	R/W	R/W	R/W
Default:			0	0	1	0	1	0

The following PLL and memory controls are available through the PLL control register:

- MEM5V        MEM5V should be set to 0 when DVDD is 3.3 volts, and 1 when DVDD is 5 volts.
- PLL5VA        PLL5VA is set to 1 when AVDD is 5 volts.
- PLL5VD        PLL5VD is set to 1 when DVDD is 5 volts. A value of 0 is used when DVDD is 3.3 volts (default).
- PPLLS         When the PLL5VA is 1 PLLS should be 1. When PLL5VA is 0 PLLS should be 0.
- PLLCAP        PLLCAP controls the loop filter capacitor of the PLL. A recommended listing of PLLCAP vs Mode is shown below.
- PLLCPI        The default value should be used.

**Register Descriptions (continued)**

**Table 26. PLL Capacitor Setting**

<b>Mode</b>	<b>PLLCAP Value</b>
0	1
1	1
2	1
3	0
4	1
5	0
6	1
7	1
8	0
9	1
10	1
11	1
12	0
13	1
14	1
15	1
16	0
17	0
18	0
19	0
20	1
21	0
22	1
23	1
24	0
25	1
26	1

**CIV Control Register**

**Symbol: CIVC**  
**Address: 21H**  
**Bits: 5**

<b>Bit:</b>	<b>7</b>	<b>6</b>	<b>5</b>	<b>4</b>	<b>3</b>	<b>2</b>	<b>1</b>	<b>0</b>
<b>Symbol:</b>				CIV25	CIV24	CIVH1	CIVH0	ACIV
<b>Type:</b>				R	R	R/W	R/W	R/W
<b>Default:</b>				0	0	0	0	1

The following controls are available through the CIV control register:

**ACIV** When the automatic calculated increment value is 1, the number calculated and present at the CIV registers will automatically be used as the increment value for subcarrier generation, removing the need for the user to read the CIV value and write in a new FSCI value. Whenever this bit is set to 1, the subcarrier generation must be forced to free-run mode (CFRB = 0).

**CIVH[1:0]** These bits control the hysteresis circuit which is used to calculate the CIV value.

**CIV[25:24]** See descriptions in the next section.

**Calculated Increment Value Register**

**Symbol: CIV**  
**Address: 22H - 24H**  
**Bits: 8**

<b>Bit:</b>	<b>7</b>	<b>6</b>	<b>5</b>	<b>4</b>	<b>3</b>	<b>2</b>	<b>1</b>	<b>0</b>
<b>Symbol:</b>	CIV#	CIV#	CIV#	CIV#	CIV#	CIV#	CIV#	CIV#
<b>Type:</b>	R	R	R	R	R	R	R	R
<b>Default:</b>	0	0	0	0	0	0	0	0

The CIV registers 22H through 24H contain a 26-bit value, which is the calculated increment value that should be used as the upper 26 bits of FSCI. This value is determined by a comparison of the pixel clock and the 14MHz clock. The bit locations and calculation of CIV are specified as the following:

<u>Register</u>	<u>Contents</u>
21H	CIV[25:24]
22H	CIV[23:16]
23H	CIV[15:8]
24H	CIV[7:0]

**Version ID Register**

**Symbol: VID**  
**Address: 25H**  
**Bits: 8**

<b>Bit:</b>	<b>7</b>	<b>6</b>	<b>5</b>	<b>4</b>	<b>3</b>	<b>2</b>	<b>1</b>	<b>0</b>
<b>Symbol:</b>	VID7	VID6	VID5	VID4	VID3	VID2	VID1	VID0
<b>Type:</b>	R	R	R	R	R	R	R	R
<b>Default:</b>	0	1	0	0	0	0	0	0

This read-only register contains a 8-bit value indicating the identification number assigned to this version of the CH7008. The default value shown is pre-programmed into this chip and is useful for checking for the correct version of this chip, before proceeding with its programming.

**Address Register**

**Symbol: AR**  
**Address: 3FH**  
**Bits: 6**

<b>Bit:</b>	<b>7</b>	<b>6</b>	<b>5</b>	<b>4</b>	<b>3</b>	<b>2</b>	<b>1</b>	<b>0</b>
<b>Symbol:</b>	Reserved	Reserved	AR5	AR4	AR3	AR2	AR1	AR0
<b>Type:</b>			R/W	R/W	R/W	R/W	R/W	R/W
<b>Default:</b>			X	X	X	X	X	X

The Address Register points to the register currently being accessed.

## Electrical Specifications

**Table 27. Absolute Maximum Ratings**

Symbol	Description	Min	Typ	Max	Units
	V <sub>DD</sub> relative to GND	- 0.5		7.0	V
	Input voltage of all digital pins <sup>1</sup>	GND - 0.5		V <sub>DD</sub> + 0.5	V
T <sub>SC</sub>	Analog output short circuit duration		Indefinite		Sec
T <sub>AMB</sub>	Ambient operating temperature	- 55		85	°C
T <sub>STOR</sub>	Storage temperature	- 65		150	°C
T <sub>J</sub>	Junction temperature			150	°C
TVPS	Vapor phase soldering (one minute)			220	°C

**Notes:**

1. Stresses greater than those listed under absolute maximum ratings may cause permanent damage to the device. These are stress ratings only. Functional operation of the device at these or any other conditions above those indicated under the normal operating condition of this specification is not recommended. Exposure to absolute maximum rating conditions for extended periods may affect reliability.
2. The device is fabricated using high-performance CMOS technology. It should be handled as an ESD sensitive device. Voltage on any signal pin that exceeds the power supply voltages by more than ± 0.5V can induce destructive latch.

**Table 28. Recommended Operating Conditions**

Symbol	Description	Min	Typ	Max	Units
V <sub>DD</sub>	DAC power supply voltage	4.75	5.00	5.25	V
AV <sub>DD</sub>	Analog supply voltage	4.75	5.00	5.25	
DV <sub>DD</sub>	Digital supply voltage	3.1	3.3	3.6	
DV <sub>DD2</sub>	Digital supply voltage (P-OUT pin) VGA controller interface = 1.8V	1.7	1.8	1.9	V
DV <sub>DD2</sub>	Digital supply voltage (P-OUT pin) VGA controller interface = 3.3V	3.1	3.3	3.6	V
RL	Output load to DAC outputs		37.5		Ω

**Table 29. Electrical Characteristics (Operating Conditions: T<sub>A</sub> = 0°C - 70°C, V<sub>DD</sub> = 5V ± 5%)**

	Video D/A resolution	9	9	9	Bits
	Full scale output current		33.89		mA
	Video level error			10	%
	V <sub>DD</sub> & AV <sub>DD</sub> (5V) current (simultaneous S-Video & composite outputs)		105		mA
	DV <sub>DD</sub> (3.3V) current		45		mA
	DV <sub>DD2</sub> (1.8V) current (15pF load)		4		mA

# Timing Information

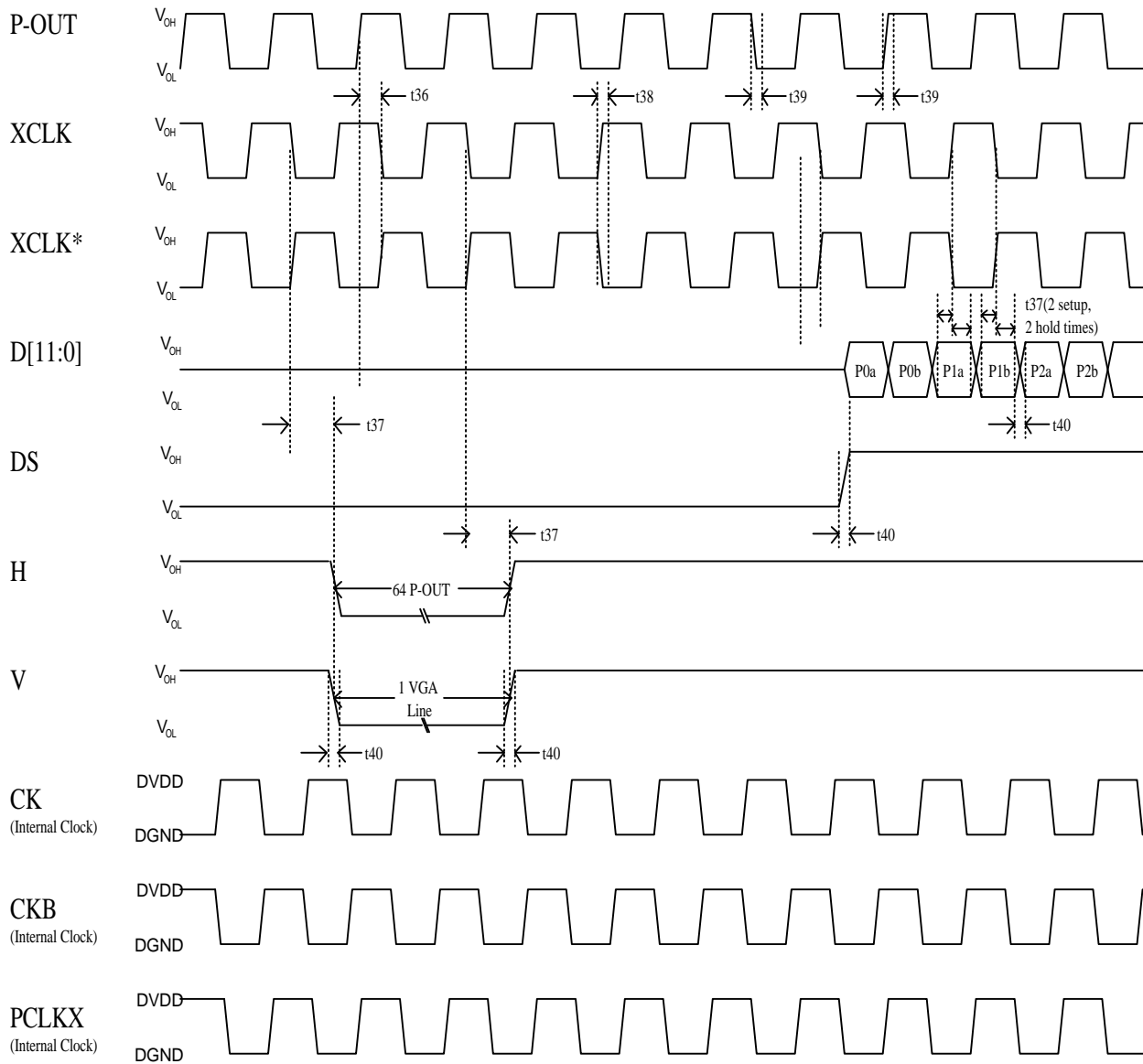

Symbol	Parameter	Min	Max	Unit
V <sub>OH</sub>	Output High level of interface signals	DVDD2 - 0.2	DVDD2 + 0.2	V
V <sub>OL</sub>	Output Low level of interface signals	-0.2	0.2	V
t <sub>36</sub>	P-OUT = VREF to XCLK = XCLK* Delay	2	9	nS
t <sub>37</sub>	XCLK = XCLK* to D[11:0], H, V & DS = VREF Setup and Hold	3		nS
t <sub>38</sub>	XCLK = XCLK* rise/fall time w/15pF load			nS
t <sub>39</sub>	P-OUT rise/fall time w/15pF load			nS
t <sub>40</sub>	D[11:0], H, V & DW rise/fall time w/15pF load			nS
DVDD2	Digital I/O Supply Voltage	1.7	3.6	V



**Table 30. Digital Inputs / Outputs**

Symbol	Description	Test Condition	Min	Typ	Max	Unit
V <sub>SDOL</sub>	SD Output Low Voltage	IOL = 2.0 mA			0.4	V
V <sub>IICIH</sub>	SD Input High Voltage		2.7		VDD + 0.5	V
V <sub>IICIL</sub>	SD Input Low Voltage		GND-0.5		1.4	V
V <sub>DATAIH</sub>	D[0-11] Input High Voltage		2.5		DVDD+0.5	V
V <sub>DATAIL</sub>	D[0-11] Input Low Voltage		GND-0.5		0.8	V
V <sub>P-OUTOH</sub>	P-OUT Output High Voltage	IOL = - 400 μA	2.8			V
V <sub>P-OUTOL</sub>	P-OUT Output Low Voltage	IOL = 3.2 mA			0.2	V

**Note:**

V<sub>IIC</sub> -refers to I<sup>2</sup>C pins SD and SC.  
V<sub>DATA</sub> - refers to all digital pixel and clock inputs.  
V<sub>SD</sub> - refers to I<sup>2</sup>C pin SD as an output.  
V<sub>P-OUT</sub> - refers to pixel data output Time - Graphics.

ORDERING INFORMATION			
Part number	Package type	Number of pins	Voltage supply
CH7008A-V	PLCC	44	3V/5V
CH7008A-T	TQFP	44	3V/5V

# Chrontel

2210 O'Toole Avenue  
San Jose, CA 95131-1326

Tel: (408) 383-9328

Fax: (408) 383-9338

www.chrontel.com

E-mail: sales@chrontel.com

©1998 Chrontel, Inc. All Rights Reserved.

Chrontel PRODUCTS ARE NOT AUTHORIZED FOR AND SHOULD NOT BE USED WITHIN LIFE SUPPORT SYSTEMS OR NUCLEAR FACILITY APPLICATIONS WITHOUT THE SPECIFIC WRITTEN CONSENT OF Chrontel. Life support systems are those intended to support or sustain life and whose failure to perform when used as directed can reasonably expect to result in personal injury or death. Chrontel reserves the right to make changes at any time without notice to improve and supply the best possible product and is not responsible and does not assume any liability for misapplication or use outside the limits specified in this document. We provide no warranty for the use of our products and assume no liability for errors contained in this document. Printed in the U.S.A.