

TL431

LINEAR INTEGRATED CIRCUIT

PROGRAMMABLE PRECISION REFERENCE

DESCRIPTION

The Contek TL431 is a three-terminal adjustable regulator with a guaranteed thermal stability over applicable temperature ranges. The output voltage may be set to any value between V_{ref} (approximately 2.5V) and 36 V with two external resistors. It provides very wide applications, including shunt regulator, series regulator, switching regulator, voltage reference and others.

FEATURES

- *Programmable output Voltage to 36V.
- *Low dynamic output impedance 0.2Ω .
- *Sink current capability of 1.0 to 100mA.
- *Equivalent full-range temperature coefficient of 50ppm/°C typical for operation over full rated operating temperature range.

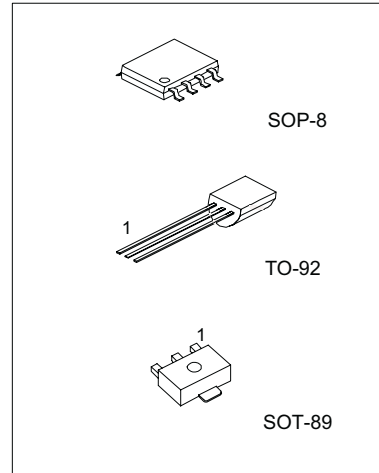

SOP-8 1: Cathode 2,3,6,7: Anode 8:Ref.
4,5: N.C.

TO-92 1: Ref; 2:Anode; 3:Cathode

SOT-89 1: Ref; 2:Anode; 3:Cathode

BLOCK DIAGRAM

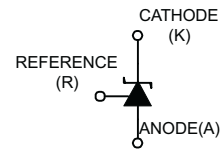
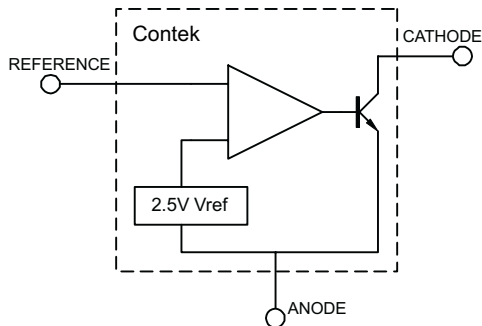

Contek Microelectronics Co.,Ltd.

<http://www.contek-ic.com> E-mail:sales@contek-ic.com

ABSOLUTE MAXIMUM RATINGS (Operating temperature range applies unless otherwise specified)

PARAMETER	SYMBOL	VALUE	UNIT
Cathode Voltage	V _{KA}	37	V
Cathode Current Range(Continuous)	I _{KA}	-100 ~ +150	mA
Reference Input Current Range	I _{ref}	0.05 ~ +10	mA
Power Dissipation	P _D	500	mW
TO-92			
SOP-8			
SOT-89		300	mW
Operating Junction Temperature	T _{opr}	-20 ~ +85	C
Storage Temperature	T _{stg}	-65 ~ +150	C

RECOMMENDED OPERATING CONDITIONS

PARAMETER	SYMBOL	MIN	TYP	MAX	UNIT
Cathode Voltage	V _{KA}	V _{REF}		36	V
Cathode Current	I _{KA}		10		mA

ELECTRICAL CHARACTERISTICS(T_a=25 C, unless otherwise specified)

PARAMETER	SYMBOL	TEST CONDITIONS	MIN	TYP	MAX	UNIT
Reference Input Voltage	V _{ref}	V _{KA} =V _{REF} , I _{KA} =10mA	2.440	2.495	2.550	V
Deviation of reference Input Voltage Over temperature(note 1)	ΔV _{ref} /ΔT	V _{KA} =V _{REF} , I _{KA} =10mA T _{MIN} ≤T _A ≤T _{MAX}		4.5	17	mV
Ratio of Change in Reference Input Voltage to the Change in Cathode Voltage	ΔV _{ref} /ΔV _{KA}	I _{KA} =10mA		-1.0	-2.7	mV/V
		V _{KA} =10V~V _{REF} V _{KA} =36V~10V		-0.5		
Reference Input Current	I _{ref}	I _{KA} =10mA, R ₁ =10kΩ, R ₂ =		1.5	4	μA
Deviation of Reference Input Current Over Full Temperature Range	ΔI _{ref} /ΔT	I _{KA} =10mA, R ₁ =10kΩ, R ₂ = T _A =full Temperature		0.4	1.2	μA
Minimum Cathode Current for Regulation	I _{KA} (min)	V _{KA} =V _{REF}		0.45	1.0	mA
Off-State Cathode Current	I _{KA} (OFF)	V _{KA} =36V, V _{REF} =0		0.05	1.0	μA
Dynamic Impedance	Z _{KA}	V _{KA} =V _{REF} , I _{KA} =1 to 100mA f1.0kHz		0.15	0.5	Ω

Note: T_{MIN}=0 C, T_{MAX}=+70 C

Remark: Reference voltage of ±1% tolerance is also available per customer's request.



TYPICAL PERFORMANCE CHARACTERISTICS

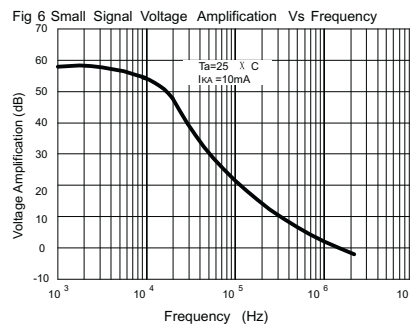
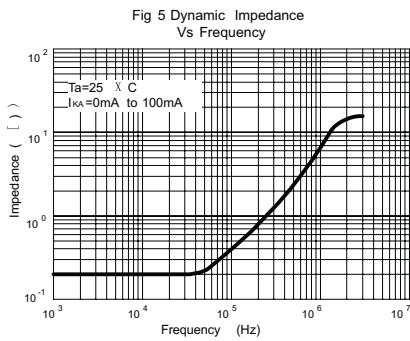
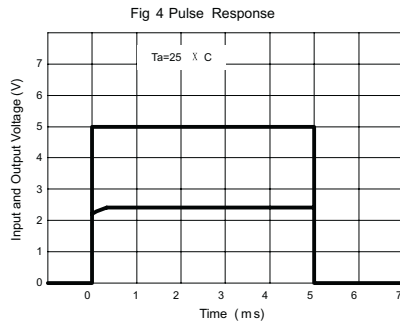
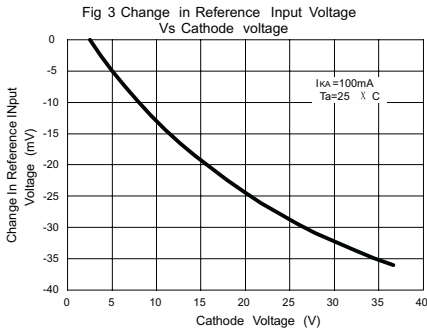
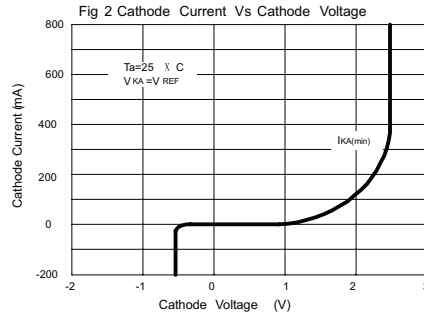
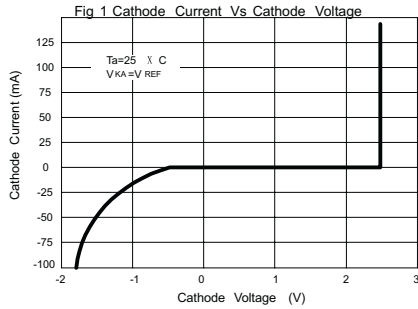

TL431

LINEAR INTEGRATED CIRCUIT

TEST CIRCUIT

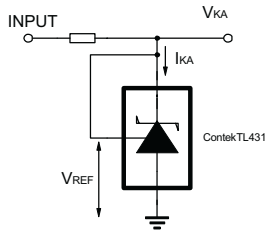

Fig 7 Test Circuit For $V_{KA}=V_{REF}$

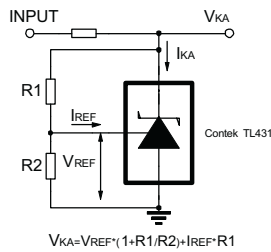

Fig 8 Test Circuit for $V_{KA} \geq V_{REF}$

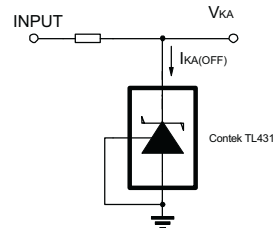

Fig 9 Test Circuit For $I_{KA(OFF)}$

APPLICATION CIRCUIT

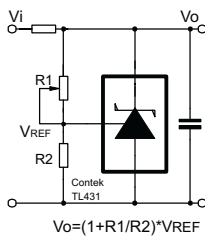

Fig 10 Shutdown Regulator

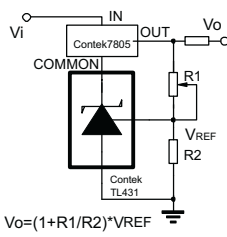

Fig 11 Output Control of a Three-Terminal Fixed Regulator

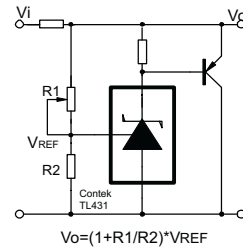

Fig 12 Higher-current Shunt Regulator

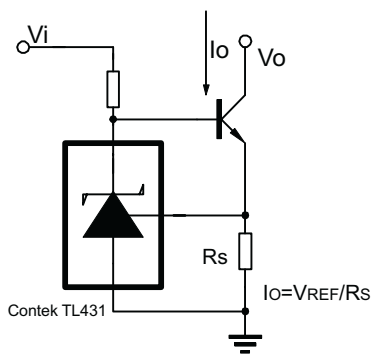

Fig 13 Constant-current Sink

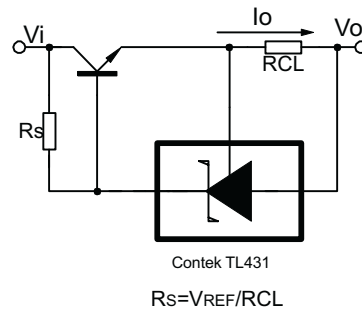

Fig 14 Current Limiting or Current Source



Contek Microelectronics Co.,Ltd.

<http://www.contek-ic.com> E-mail:sales@contek-ic.com