

TL494

LINEAR INTEGRATED CIRCUIT

VOLTAGE MODE PWM CONTROL CIRCUIT

DESCRIPTION

The Contek TL494 incorporates all the functions required in the construction of a pulse-width modulation switching circuit. Designed primarily for switching power supply control or DC-DC converters, it offers the systems engineer the flexibility to tailor control circuitry to its own application.

FEATURES

- *Complete PWM power control circuitry
- *Uncommitted outputs for 200 mA sink or source current
- *Output control selects single ended or push pull operation
- *Internal circuitry prohibits double pulses over total range
- *Easy synchronization

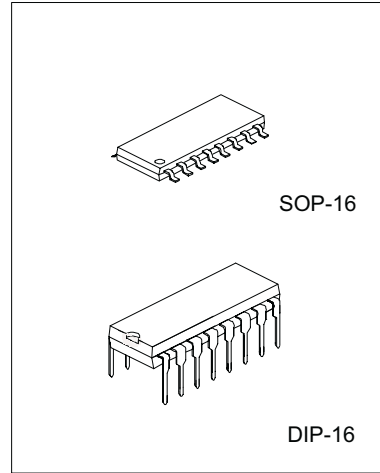

ABSOLUTE MAXIMUM RATINGS(Unless otherwise noted all is over operating free air temperature range)

PARAMETER	SYMBOL	VALUE	UNIT
Supply Voltage(note 1)	V_{CC}	41	V
Amplifier Input Voltage	V_I	$V_{CC}+0.3$	V
Collector Output Voltage	V_O	41	V
Collector Output Current	I_{CO}	250	mA
Continuous Total Dissipation at(or for below) 25 C Free Air Temperature(note 2)	P_D	1000	mW
Operating Temperature Range	T_{opr}	0 TO 70	C
Storage Temperature Range	T_{sta}	-65 TO 150	C
Lead Temperature 1.6mm from Case for 60 Sec.	T_{case}	300	C

note 1: All voltage values, except differential voltages are with respect to the network ground terminal.

note 2:For operation above 25 C free-air temperature, the dissipation derates with 9.2mW/ C.



Contek Microelectronics Co.,Ltd.

<http://www.contek-ic.com> E-mail:sales@contek-ic.com

TL494

LINEAR INTEGRATED CIRCUIT

BLOCK DIAGRAM

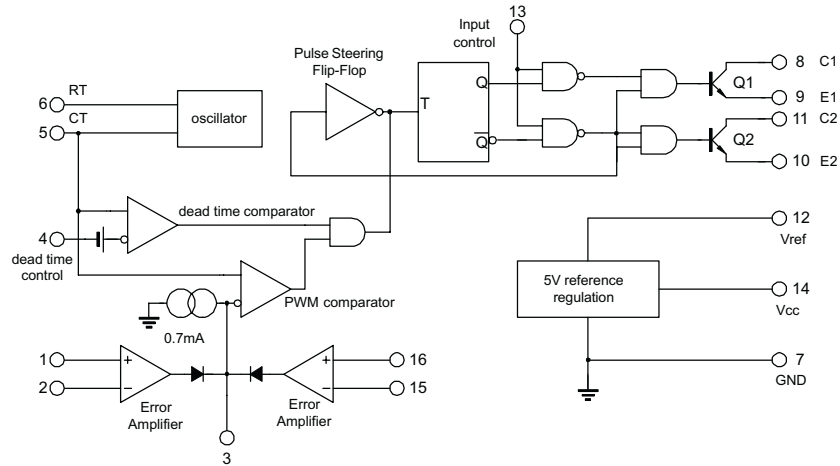

RECOMMENDED OPERATING CONDITIONS

PARAMETER	SYMBOL	VALUE		UNIT
		MIN	MAX	
Supply Voltage	V_{cc}	7	40	V
Amplifier Input Voltage	V_i	-0.3	$V_{cc}-2$	V
Collector Output Voltage	V_o		40	V
Collector Output Current(each Transistor)	I_c		200	mA
Current into Feedback	I_f		0.3	mA
Timing Capacitor	CT	0.47	10000	nF
Timing Resistor	RT	1.8	500	k Ω
Oscillator Frequency	f_{osc}	1	300	kHz
Operating Free-Air Temperature	T_a	0	70	C

ELECTRICAL CHARACTERISTICS

(Over recommended operating free-air temperature range, $V_{cc}=15V, f=1kHz$, Unless otherwise specified)

PARAMETER	TEST CONDITIONS	MIN	TYP	MAX	UNIT
Reference Section					
Output Voltage	$I_o=1mA$	4.75	5	5.25	V
Input Regulation	$V_{cc}=7V$ to $40V$		2	25	mV
Output Regulation	$I_o=1$ to $10mA$		1	15	mV
Output Voltage Change with Temperature	$\Delta T_A=MIN$ to MAX (note 2)		0.2	1	%
Short-Circuit Output Current	$V_{ref}=0$		35		mA
Oscillator Section					
Frequency	$C_T=0.01\mu F, R_T=120k\Omega$		10		kHz



Contek Microelectronics Co.,Ltd.

<http://www.contek-ic.com> E-mail:sales@contek-ic.com

PARAMETER		TEST CONDITIONS	MIN	TYP	MAX	UNIT
Standard Deviation of Frequency		All Values of Vcc CT, RT, TA constant		10		%
Frequency Change with Voltage		Vcc=7v to 40V, Ta=25 C		0.1		%
Frequency Change with Temperature		CT=0.01μF, RT=12kΩ, ΔTA=MIN to MAX			12	%
Amplifier Section						
Input Offset Voltage	Error	Vo(pin 3)=2.5V		2	10	mV
Input Offset Current		Vo(pin 3)=2.5V		25	250	nA
Input Bias Current		Vo(pin 3)=2.5V		0.2	1	μA
Common-Mode Input Voltage Range	Error	Vcc=7V to 40 V	-0.3 to Vcc-2			V
Open-Loop Voltage Amplification		ΔVo=3V, Vo=0.5V to 3.5V	70	95		dB
Unity-Gain Bandwidth				800		KHz
Common-Mode Rejection Ratio	Error	Vcc=40V, TA=25 C	65	80		dB
Output Sink Current(pin 3)		VID=-15mV to -5V V(pin 3)=0.5V	0.3	0.7		mA
Output source Current(pin 3)		VID=15mV to -5V V(pin 3)=3.5V	-2			mA
Output Section						
Collector off-state current		VCE=40V, Vcc=40V		2	100	μA
Emitter off-state Current		VCC=VC=40V, VE=0			-100	μA
Collector -emitter Saturation Voltage	Common-emitter	VE=0, Ic=200mA		1.1	1.3	V
	Emitter-Follower	Vc=15V, IE=-200mA		1.5	2.5	
Output Control Input Current		Vi=Vref			3.5	mA
Dead Time Control Section						
Input bias (pin 4)		Vi=0 to 5.25V		-2	-10	μA
Maximum duty cycle, each output		VI(pin 4)=0	45			%
Input threshold Voltage(pin 4)		Zero duty Cycle		3	3.3	V
		Maximum duty cycle	0			
PWM comparator Section						
Input Threshold Voltage(pin 3)		Zero Duty cycle		4	4.5	V
Input Sink Current (pin 3)		Vpin 3= 0.7V	0.3	0.7		mA
Total Device						
Standby Supply Current	Vcc=15V	pin 6 at Vref, all other Inputs and outputs open		6	10	mA
	Vcc=40V			9	15	
Average supply current		Vpin 4=2V		7.5		mA
Switching Characteristics, Ta=25 C						
Output Voltage Rise Time		Common-emitter configuration		100	200	ns
Output Voltage Fall Time				25	100	ns
Output Voltage Rise Time		Emitter-follower configuration		100	200	ns
Output Voltage Fall Time				40	100	ns

note 1: All typical Values except for temperature coefficient are at Ta=25 C.

note 2: For conditions shown as MIN or MAX, use appropriate value under recommended operating conditions.

note 3: Duration of the short-circuit should not exceed one second.



TL494

LINEAR INTEGRATED CIRCUIT

note 4: Standard deviation is a measure of the statistical distribution the mean as derived from the formula :

$$\sigma = \sqrt{\frac{\sum_{n=1}^N (X_n - \bar{X})^2}{N-1}}$$

TEST CIRCUIT

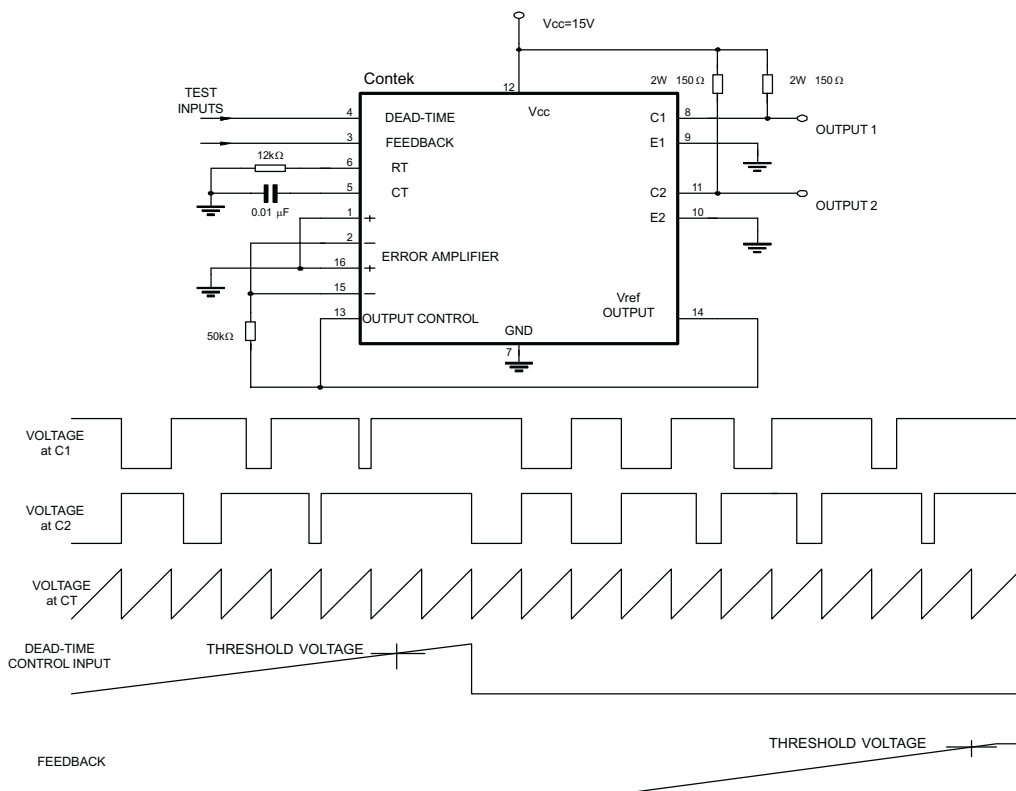

FIG 1. OPERATIONAL TEST CIRCUIT AND WAVEFORMS



Contek Microelectronics Co.,Ltd.

<http://www.contek-ic.com> E-mail:sales@contek-ic.com

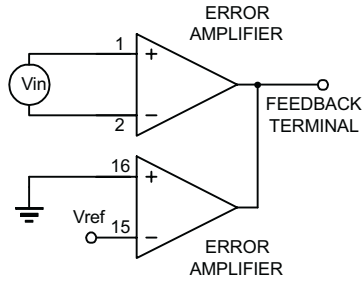

FIG 2. AMPLIFIER CHARACTERISTICS

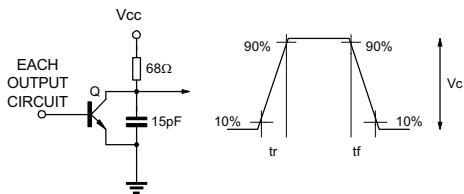

FIG. 3 COMMON-EMITTER CONFIGURATION

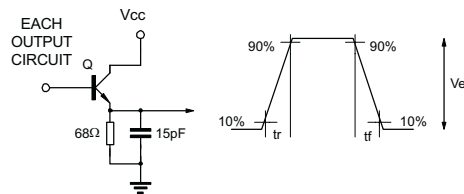
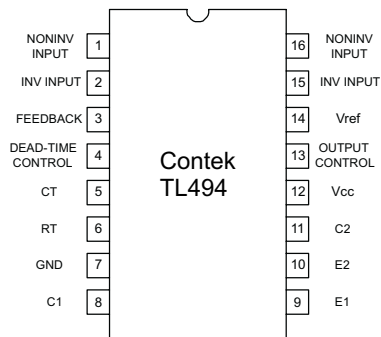

FIG. 4 EMITTER-FOLLOWER CONFIGURATION

PIN CONFIGURATIONS



TYPICAL PERFORMANCE CHARACTERISTICS

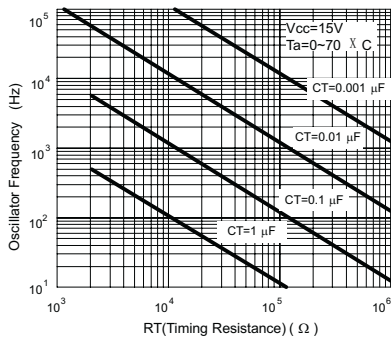

FIG 5. Oscillator Frequency and Frequency Variation Vs Timing Resistance

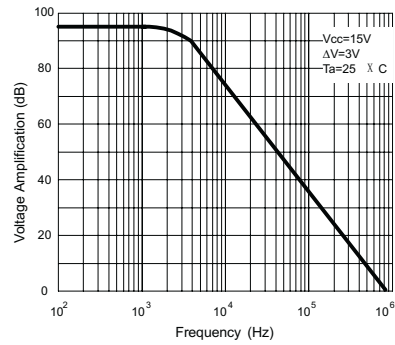

Fig.6 Amplifier Voltage Amplification