

FM209 and FM214

9600/14400 bps MONOFAX[®] Modem Family

The Conexant™ FM209 and FM214 MONOFAX[®] modem family offers synchronous 9600 or 14400 bits per second (bps) half-duplex modems with error detection, voice and audio codecs, full-duplex speakerphone, automatic speech recognition, DTMF reception, V.23 full-duplex, Type I Caller ID and Type II Caller ID CAS detection. It has low power consumption and is housed in a single 128-pin Thin Quad Flat Pack (TQFP) device package. The modem's small size and low power consumption allow the design of compact system enclosures for use in both office and home environments. Table 1 lists the FM209/FM214 models and features.

Group 3 Facsimile Modem

The modem can operate over the public switched telephone network (PSTN) through line termination provided by a data access arrangement (DAA).

The modem satisfies the requirements specified in ITU-T recommendations V.33, V.17, V.29, V.27 ter, V.21 Channel 2 (FSK), T.4, and meets the binary signaling requirements of T.30.

The modem operates at 14400, 12000, 9600, 7200, 4800, 2400, or 300 bps. The modem supports the V.17 signaling rates of 14400, 12000, 9600, and 7200 bps using trellis-coded modulation (TCM). In addition, the modem supports V.27 ter and V.17 short trains.

The modem can also perform HDLC framing according to T.30 at 14400, 12000, 9600, 7200, 4800, 2400, or 300 bps.

A FSK flag pattern (7E) detector facilitates FSK detection during V.33, V.17, V.29, and V.27 ter reception.

The modem includes a programmable single/dual tone transmitter, a programmable DTMF receiver, three programmable tone detectors (which operate concurrently with the V.21 Channel 2 receiver), and a ring detector. The transmit output level is also programmable.

Voice and Audio Codecs (-V Option)

The voice coder/decoder (codec) compresses voice at an average rate of 2.9 kbps or at a fixed rate of 4.7 kbps with near toll quality playback at various pitch synchronized playback speeds. An average rate of 2.9 kbps provides 24 minutes of stored voice messages in 4 Mbits of memory. This voice codec allows the host controller to efficiently store and playback digital incoming messages (ICMs) and outgoing messages (OGMs).

The ADPCM audio codec compresses audio signals (music/voice) at 32 kbps or 24 kbps for highest fidelity coding and reproduction.

The PCM audio codec allows the host controller to transmit and receive uncompressed audio signals.

Distinguishing Features

- Group 3 facsimile transmission/reception
 - ITU-T V.17 and V.33 (FM214 models)
 - ITU-T V.29, V.27 ter, T.30, V.21 Channel 2, T.4
 - ITU-T V.17 and V.27 ter short train
 - ITU-T V.17 short trains
 - HDLC framing at all speeds
 - Receive dynamic range: 0 dBm to -43 dBm
 - Automatic adaptive equalization
 - Fixed and programmable digital compromise equalization
 - DTMF detect and tone detect
 - ITU-T V.21 Channel 2 FSK 7E Flag Detect
 - Ring detector
 - Programmable transmit level
 - Programmable single/dual tone transmission
- Voice codec (-V Option)
 - 24 minutes of voice storage per 4 Mbit memory
 - Near toll quality voice recording and playback
 - Programmable AGCs
 - Programmable line/microphone input and line/speaker output filters
 - Error correction coding allows ARAM usage
 - DTMF detect, tone detect, and tone transmit
 - Type II Caller ID CAS detection
 - Pitch synchronized fast and slow playback
 - Near-end echo cancellation
- ADPCM audio codec (-V Option)
 - High fidelity recording and playback of audio signals
 - 32 kbps and 24 kbps
 - Programmable AGCs
 - Programmable line/microphone input and line/speaker output filters
 - DTMF detect, tone detect, and tone transmit
 - Type II Caller ID CAS detection
 - Near-end echo cancellation
- PCM audio codec
 - 128 kbps and 64 kbps
 - DTMF detect and tone detect
 - Type II Caller ID CAS detection
 - Near end echo cancellation

FM209 and FM214 9600/14400 bps MONOFAX Modem Family

- Full-Duplex Speakerphone (-S Option)
 - Acoustic Echo Cancellation
 - Line echo cancellation or secondary acoustic echo cancellation
 - Programmable microphone and speaker AGCs
 - Programmable line and speaker output filters
 - Microphone and speaker volume control and muting
 - Auto fallback toward pseudo-duplex operation under poor operating conditions
 - Programmable handset echo simulation in handset operation
 - High gain half-duplex mode
 - Intercom support
 - DTMF detect and 3 tone detectors
 - Type II Caller ID CAS detection
 - Two dual tone transmitters
 - Conversation recording and message playback with Voice or ADPCM audio codec (-VS option)
- Automatic Speech Recognition (-R Option)
 - Speaker Dependent (SD) and Speaker Independent (SI) isolated word recognition
 - SI Vocabulary (English) for hands-free voice control of dialing, telephone answering machine and fax functions
 - Active word list for recognition selected by host controller
 - Supports speech input from microphone, local handset, or telephone line
 - SI word models trained off-line and stored in DSP ROM
 - SD word models trained in real-time, stored in (off-chip) NVRAM and downloaded to DSP RAM
 - Supports up to 30 Active simultaneous SD words
 - SD training - single utterance or multiple utterances
 - 2.5 second maximum speech length for SD training
 - Rejection capability provided for SI mode
- Room monitor
 - DTMF detect, tone detect and tone transmit
 - Type II Caller ID CAS detection
 - Near end echo cancellation
 - Monitor recording and message playback with Voice or Audio codec (-V option)
- V.23 and Type I Caller ID
 - Full-duplex modes:
 - TX = 75 bps, RX = 1200 bps
 - TX = 1200 bps, RX = 75 bps
 - Half-duplex mode:
 - TX = RX = 1200 bps
 - Serial and parallel data modes
 - Programmable parallel data mode
 - 5, 6, 7, or 8 data bits
 - 1 or 2 Stop bits
 - Mark, Space, Even, or Odd Parity
 - Break function
 - Transmitter squelch
 - Compromise equalizer
- Interface Memory Interrupt
- Eight general purpose input (GPI) and eight general purpose output (GPO) pins for host assignment
- DTE Interface: two alternate ports
 - Selectable microprocessor bus (6500 or 8085)
 - ITU-T V.24 (EIA/TIA-232-E compatible) interface
- TTL and CMOS compatible
- 3.3V/5V operation
- Power Consumption:
 - Operating Mode:
 - 200 mW (Basic)
 - 275 mW (-V option)
 - 300 mW (-VS option)
 - Sleep Mode:
 - 1 ma (Basic and -V option)
 - 1 ma (-VS option)
- Packaging
 - 128-pin TQFP (thin quad flat pack)
 - Software compatible with all MONOFAX modems

Information provided by Conexant Systems, Inc. is believed to be accurate and reliable. However, no responsibility is assumed by Conexant for its use, nor any infringement of patents or other rights of third parties which may result from its use. No license is granted by implication or otherwise under any patent rights of Conexant other than for circuitry embodied in Conexant products. Conexant reserves the right to change circuitry at any time without notice. This document is subject to change without notice.

Conexant and "What's Next in Communications Technologies" are trademarks of Conexant Systems, Inc.

Product names or services listed in this publication are for identification purposes only, and may be trademarks or registered trademarks of their respective companies. All other marks mentioned herein are the property of their respective holders.

©1999, Conexant Systems, Inc.

All Rights Reserved.

Selectable error correction coding allows storage in audio grade RAMs (ARAMs). Echo cancellation techniques employed during playback allow DTMF, Type II Caller ID CAS detection, and tone detection during voice/audio codec operation to support user selectable features. Dual or single tone transmission is supported. The coder can record messages from either the primary or secondary IA.

Speakerphone (-S Option)

The full-duplex speakerphone provides hands-free telephone conversation employing acoustic and line echo cancellation and supports intercom conversation employing dual acoustic echo cancellation.

The optional half-duplex speakerphone provides hand-free telephone/intercom conversation with exceptional high gain.

The speakerphone algorithm constantly adjusts its parameters to deliver the best performance during real-time conditions, allowing automatic fallback from full-duplex to pseudo-duplex. The host controller can easily set up the speaker mute, microphone mute, automatic gain control (AGC) enable/disable, microphone level, line level, speaker volume, tone transmit, and handset functions.

Conversation recording and message playback are supported during the speakerphone operation. DTMF detection, Type II Caller ID CAS detection, and three tone detectors are also supported.

Automatic Speech Recognition (-R Option)

Automatic Speech Recognition (ASR) consists of Speaker Independent (SI) North American English isolated word recognition for a predefined 69 word vocabulary list, Speaker Dependent (SD) isolated word training, and SD isolated word recognition functions.

V.23 Full-Duplex Modem and Caller ID

Both full-duplex transmit and receive (with asymmetric 1200/75 bps connection) and half-duplex (1200 bps) asynchronous V.23 are supported, as well as both serial and parallel interfaces to the modem. The V.23 algorithm includes an optional, programmable, receive compromise equalizer which is active in both V.23 and Caller ID modes.

Common applications for V.23 include France's Minitel and Japan's Lowest Cost Routing.

General Purpose Output (GPO) and General Purpose Input (GPI) pins are available for host assignment.

Additional design information is described in the FM209 and FM214 MONOFAX Modem Family Designer's Guide (Order Number 1175).

Table 1. FM209/FM214 Models and Features

Modem Model	Supported Features			
	Maximum Line Speed	Voice and Audio Codecs (-V)	Full Duplex Speakerphone (-S)	Automatic Speech Recognition (-R)
FM214-VSR	14.4 kbps	√	√	√
FM214-VS	14.4 kbps	√	√	--
FM214-V	14.4 kbps	√	--	--
FM214	14.4 kbps	--	--	--
FM209-VSR	9.6 kbps	√	√	√
FM209-VS	9.6 kbps	√	√	--
FM209-V	9.6 kbps	√	--	--
FM209	9.6 kbps	--	--	--

Technical Specifications

Configurations, Symbol Rates and Data Rates

The selectable modem configurations, along with the corresponding symbol (baud) rates and data rates, are listed in Table 2.

Scrambler/Descrambler

The modem incorporates a self-synchronizing scrambler/descrambler in accordance with ITU-T V.33, V.17, V.29, and V.27 ter recommendations, depending upon the selected configuration.

Data Encoding

The data encoding conforms to ITU-T recommendations V.33, V.17, V.29, V.27 ter, V.21 Channel 2, and V.23.

Fixed Digital Cable Compromise Equalizer

Compromise equalization can improve performance when operating over low quality lines. The modem has a selectable fixed digital compromise cable equalizer in the high speed receive and transmit data path.

Transmitted Data Spectrum

The transmitted data spectrum is shaped in the baseband by an excess bandwidth finite impulse response (FIR) filter with the following characteristics:

When operating at 2400 baud, the transmitted spectrum is shaped by a square root of 20% raised cosine filter.

When operating at 1600 baud, the transmitted spectrum is shaped by a square root of 50% raised cosine filter.

When operating at 1200 baud, the transmitted spectrum is shaped by a square root of 90% raised cosine filter.

The out-of-band transmitter energy levels in the 4 - 50 kHz frequency range are below -55.0 dBm.

Transmit Level

The transmitter output level is programmable in the DSP RAM from 0 dBm to -15.0 dBm and is accurate to ± 1.0 dB. The modem adjusts the output level by digitally scaling the output to the transmitter's digital-to-analog converter.

Turn-on Sequence

Transmitter turn-on sequence times are shown in Table 3.

Receive Dynamic Range

The receiver satisfies PSTN performance requirements for received line signal levels from 0 dBm to -43 dBm measured at the Receiver Analog Input (RXA) input. An external input buffer must be supplied between RXA and LINEIN.

The default values of the programmable Received Line Signal Detector (RLSD#) turn-on and turn-off threshold levels are -43 dBm and -48 dBm, respectively. The RLSD# threshold levels can be programmed over the following range:

Turn on: -10 dBm to -47 dBm

Turn off: -10 dBm to -52 dBm

Automatic Adaptive Equalizer

An adaptive equalizer in ITU-T V.33, V.17, V.29 and V.27ter modes compensates for transmission line amplitude and group delay distortion.

Receiver Timing

The timing recovery circuit can track a $\pm 0.01\%$ frequency error in the associated transmit timing source.

Carrier Recovery

The carrier recovery circuit can track a ± 7 Hz frequency offset in the received carrier.

Turn-off Sequence

Transmitter turn-off sequence times are shown in Table 4.

Clamping

Received Data (RXD) is clamped to a constant mark whenever RLSD# is off.

V.23 Full-Duplex Features

The modem can transmit and detect Break signals (continuous Space).

The Mark and Space frequencies are 1300 and 2100 Hz, respectively, for 1200 bps, and 390 and 450 Hz, respectively, for 75 bps.

Additional features include an optional host programmable Receive Compromise Equalizer for V.23 1200 bps reception and Caller ID mode.

Default transmitter turn-on/turn-off sequence times are 10.5 ms (RTS On to CTS On) and 2.2 ms (RTS Off to CTS Off).

Table 2. Configurations, Signaling Rates, and Data Rates

Configuration	Modulation ¹	Carrier Frequency (Hz) ±0.01%	Data Rate (bps) ±0.01%	Baud (Symbols/Sec.)	Bits /Symbol	Constellation Points
V.17/V.33 14400 ²	TCM	1700 or 1800	14400	2400	6	128
V.17/V.33 12000 ²	TCM	1700 or 1800	12000	2400	5	64
V.17 9600 ²	TCM	1700 or 1800	9600	2400	4	32
V.17 7200 ²	TCM	1700 or 1800	7200	2400	3	16
V.29 9600	QAM	1700	9600	2400	4	16
V.29 7200	QAM	1700	7200	2400	3	8
V.29 4800	QAM	1700	4800	2400	2	4
V.27 ter 4800	DPSK	1800	4800	1600	3	8
V.27 ter 2400	DPSK	1800	2400	1200	2	4
V.21 Channel 2 300	FSK	1650, 1850	300	300	1	–
V.23 receive HDX	FSK	1300, 2100	1200	1200	1	–
V.23 1200/75	FSK	1300, 2100/ 390, 450	1200/75	1200	1	–
Type I Caller ID	FSK	1200, 2200	1200	1200	1	–
Notes:						
1. Modulation legend: QAM: Quadrature Amplitude Modulation DPSK: Differential Phase Shift Keying FSK: Frequency Shift Keying TCM: Trellis-Coded Modulation						
2. FM214 models only.						

Table 3. Turn-On Sequence Times

Configuration	RTS# On to CTS# On	
	Echo Protector Tone Disabled	Echo Protector Tone Enabled
V.17/V.33	1393 ms	1600 ms
V.17 Short Train	142 ms	349 ms
V.29 Long Train	253 ms	441 ms
V.29 Short Train	75 ms	282 ms
V.27 ter 4800 bps Long Train	708 ms	915 ms
V.27 ter 4800 bps Short Train	50 ms	257 ms
V.27 ter 2400 bps Long Train	943 ms	1150 ms
V.27 ter 2400 bps Short Train	67 ms	274ms
V.21 Channel 2 300 bps	≤14 ms	≤14 ms

Table 4. Turn-Off Sequence Times

Configuration	Data and Scrambled Ones	No Transmitted Energy	Total
V.33/V.17	13.3 ms	20 ms	33.3 ms
V.17 Short Train	13.3 ms	20 ms	33.3 ms
V.29 Long Train and Short Train	5 ms	20 ms	25 ms
V.27 ter 4800 bps Long Train	7 ms	20 ms	27 ms
V.27 ter 4800 bps Short Train	7 ms	20 ms	27 ms
V.27 ter 2400 bps Long Train	10 ms	20 ms	30 ms
V.27 ter 2400 bps Short Train	10 ms	20 ms	30 ms
V.21 Channel 2 300 bps	7 ms	0 ms	7 ms

Notes:

1. In parallel data mode, the turn-off sequence may be extended by 8 bit times.
2. In HDLC mode, the turn-off sequence may be extended by more than 8 bit times.

Caller ID Reception

Caller ID reception (CID) allows Customer Premises Equipment (CPE) to receive a calling party's directory number which includes the date and time of the call. For Type I Caller ID this information is contained in the first 4-second silent interval in the ring cycle. For Type II Caller ID support an ACK signal is sent by the CPE in response to a CAS tone, after which the calling party information from the Stored Program Control Switching System (SPCS) can be received by the CPE.

Tone Generation

The modem can generate voice-band single or dual tones from 0 Hz to 4800 Hz with a resolution of 0.15 Hz and an accuracy of 0.01%. Tones over 3000 Hz are attenuated. Dual tone generation allows the modem to operate as a programmable DTMF dialer.

Tone Detectors

All three tone detectors operate in all receive modes. The tone detectors can also operate as one 12th order filter.

The filter coefficients of each filter are host programmable in RAM. The output of the tone detector filter goes to an energy detector.

Hardware Interface

The Fax, Digital Telephone Answering Machine (DTAM), and Speakerphone hardware interface signals are shown in Figure 1, Figure 2, and Figure 3. Any point that is active when exhibiting the relatively more negative voltage of a two-voltage system (0 VDC for TTL or -12 VDC for EIA/TIA-232-E) is called active low and is represented by a small circle at the signal point. Active low signals are indicated by a pound sign (#), (RESET#).

Edge-triggered clocks are indicated by a small triangle (DCLK).

A small half circle denotes open-collector (open-source or open-drain) outputs (signal IRQ#).

A clock intended to activate logic on its rising edge (low-to-high transition) is called active high, while a clock intended to activate logic on its falling edge (high-to-low transition) is called active low. When clock input is associated with a small circle, the input activates on a falling edge. If no circle is shown, the input activates on a rising edge.

The pin assignments for the 128-pin TQFP are shown in Figure 4.

General Specifications

The modem power and environmental requirements are listed in Table 5 and Table 6, respectively.

Table 5. Current and Power Requirements

Mode	Option	Current (Typ.) @25°C
3.3V ± 5%.	DVAA	2.5 ma
V _{DD}	Basic	50 ma
V _{DD}	- V	72 ma
V _{DD}	- VS	80 ma
5V ± 5% V _{GG}		5.5 ma
	Basic	.25 ma
	- V	.30 ma
	- VS	.30 ma

Note: Input Ripple ≤0.1 V_{peak-peak}. The amplitude of any frequency between 20 kHz and 150 kHz must be less than 500 μV_{peak}.

Table 6. Environmental Requirements

Parameter	Specification
Temperature	
Operating	0°C to +70°C (32°F to 158°F)
Storage	-55°C to +125°C (-67°F to 257°F)
Relative Humidity	Up to 90% non-condensing, or a wet bulb temperature up to 35°C, whichever is less.

Software Interface

Modem functions are implemented in firmware executing in the modem DSP. The DSP RAM interface memory bits, access functions, codes, and registers are defined in the Designer's Guide.

Interface Memory

The DSP communicates with the host processor by means of a dual-port, interface memory. This interface memory contains thirty-two 8-bit registers, labeled register 00h through 1Fh. Each register can be read or written by the host and the DSP.

The host controls the modem operation by writing control bits to DSP interface memory and writing parameter values to DSP RAM through interface memory. The host monitors the modem operation by reading status bits from DSP interface memory and reading parameter values from DSP RAM through interface memory. An interface memory interrupt is provided.

DSP RAM Access

The DSP contains 16-bit word RAM. Because the DSP is optimized for performing complex arithmetic, the RAM is organized into real (X RAM) and imaginary (Y RAM) parts. The host processor can read or write both the X RAM and the Y RAM.

DSP interface memory mediates data exchange between the host and DSP RAM. The address stored in interface memory RAM address registers by the host determines the DSP RAM address for data access.

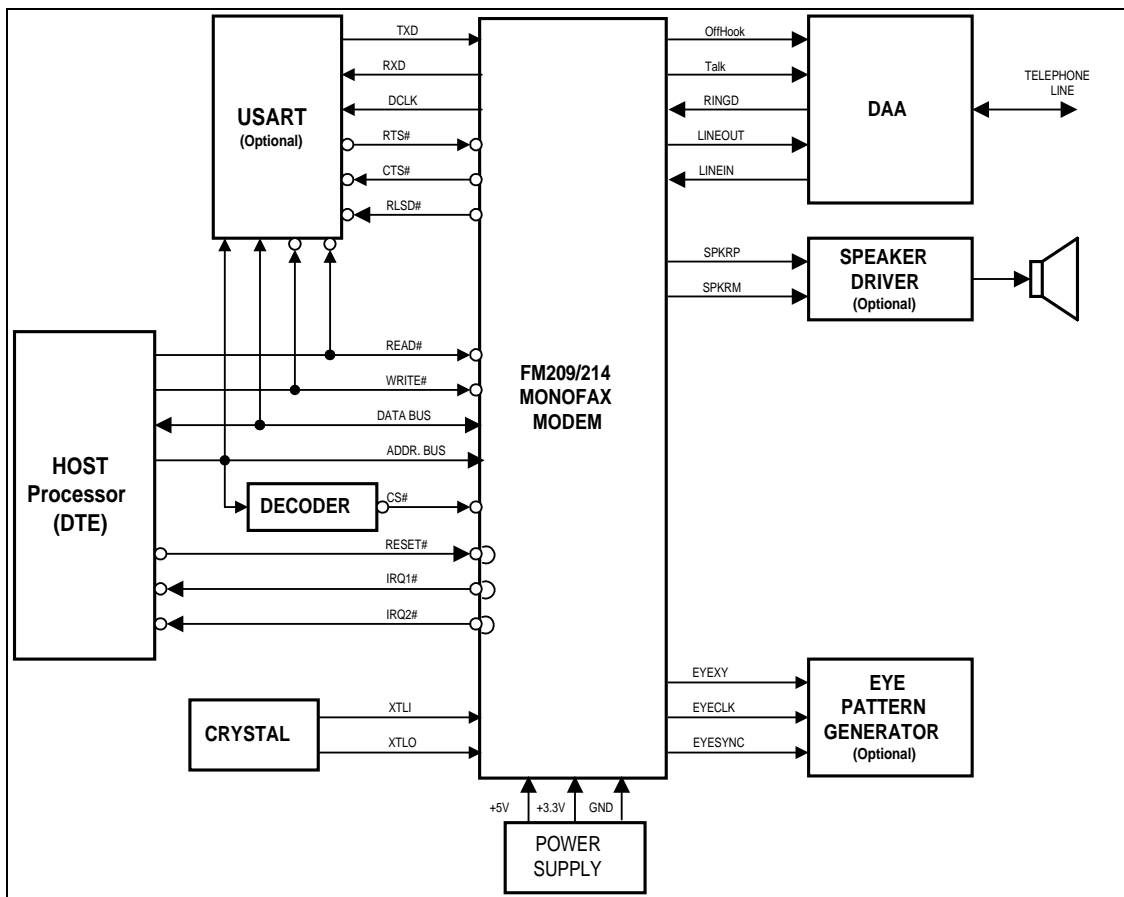

Figure 1. Modem Functional Interconnect Diagram (Fax)

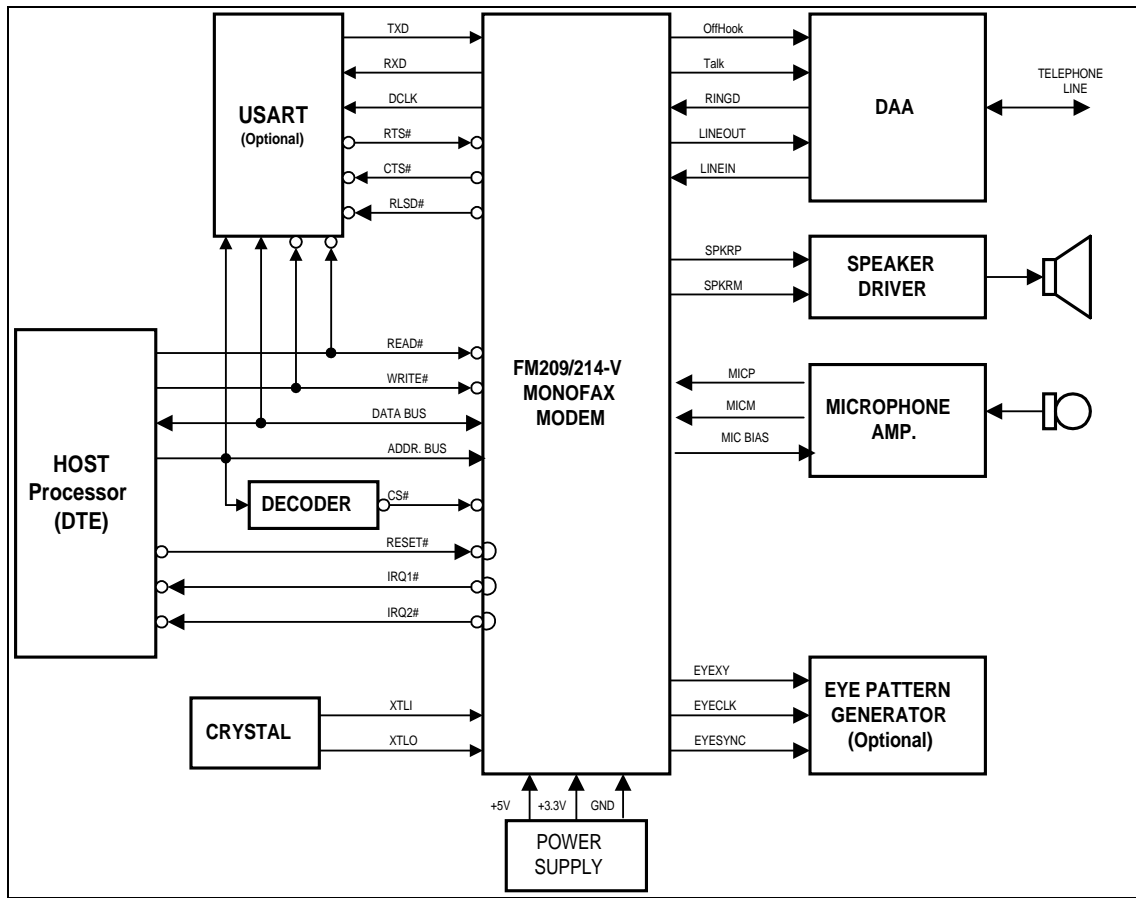

Figure 2. Modem Functional Interconnect Diagram (Fax and DTAM)

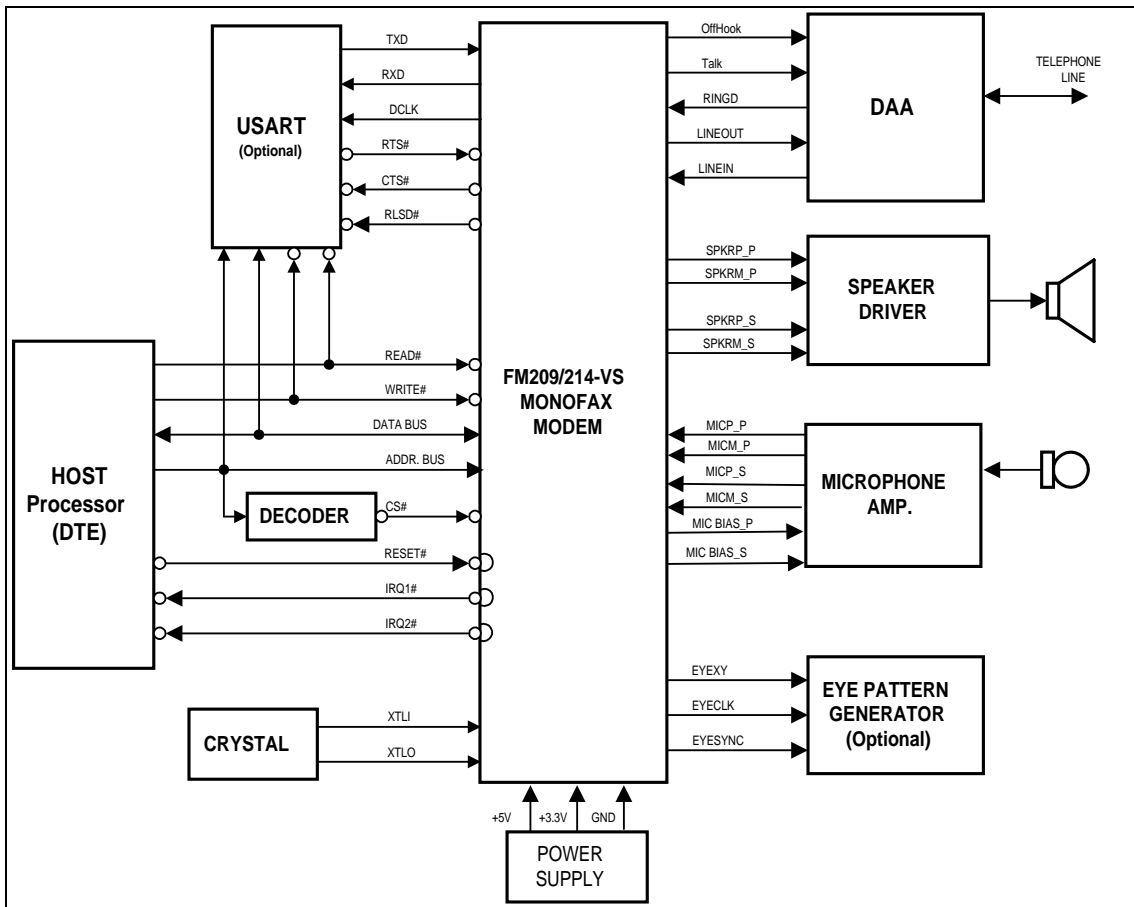

Figure 3. Modem Functional Interconnect Diagram (Fax, DTAM, and Speakerphone)

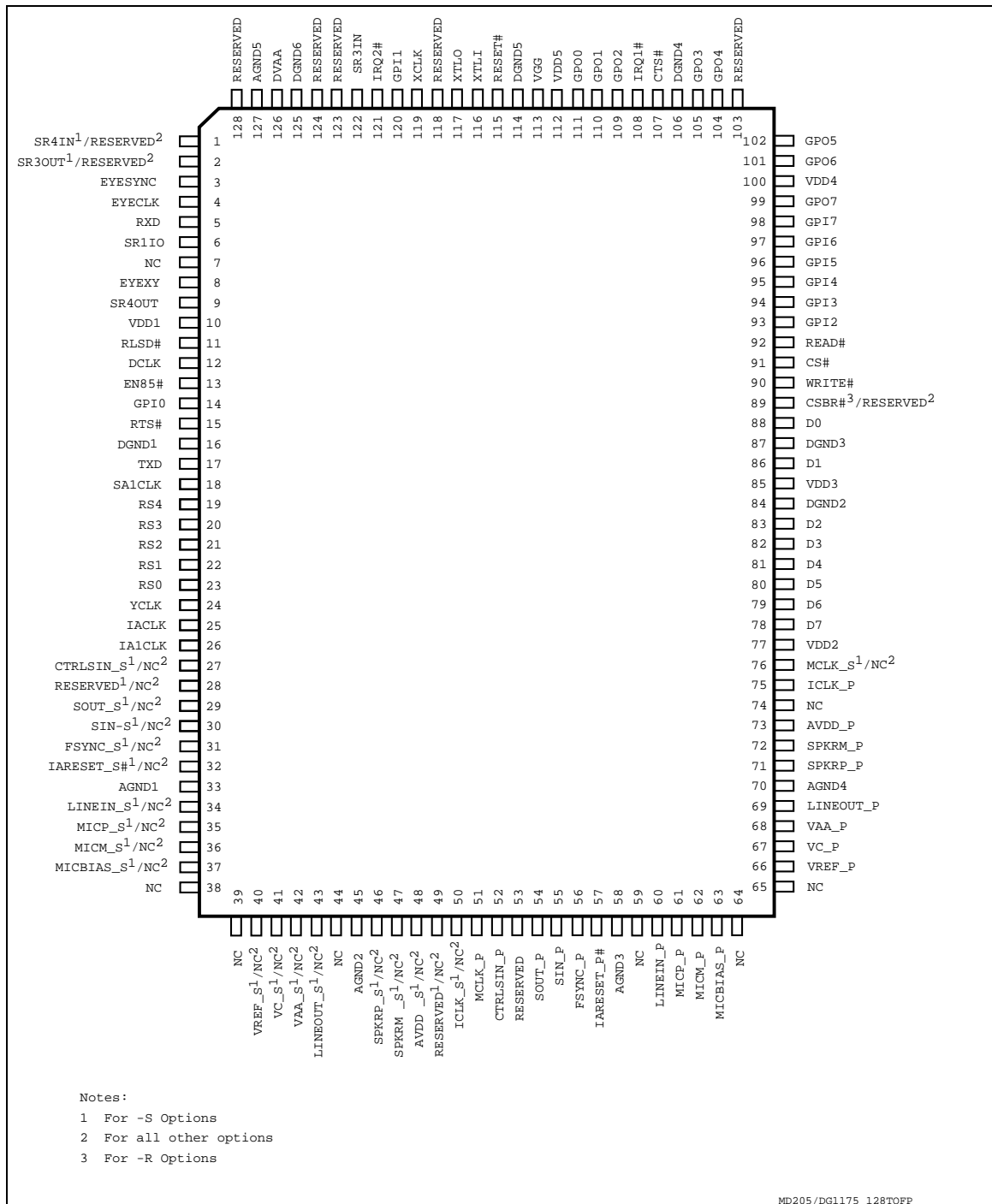

Figure 4. Pin Signals - 128-Pin TQFP



Further Information

literature@conexant.com
1-800-854-8099 (North America)
33-14-906-3980 (International)

Web Site

www.conexant.com

World Headquarters

Conexant Systems, Inc.
4311 Jamboree Road
P. O. Box C
Newport Beach, CA
92658-8902

Phone: (949) 483-4600
Fax: (949) 483-6375

U.S. Florida/South America

Phone: (813) 799-8406
Fax: (813) 799-8306

U.S. Los Angeles

Phone: (805) 376-0559
Fax: (805) 376-8180

U.S. Mid-Atlantic

Phone: (215) 244-6784
Fax: (215) 244-9292

U.S. North Central

Phone: (630) 773-3454
Fax: (630) 773-3907

U.S. Northeast

Phone: (978) 692-7660
Fax: (978) 692-8185

U.S. Northwest/Pacific West

Phone: (408) 249-9696
Fax: (408) 249-7113

U.S. South Central

Phone: (972) 773-0723
Fax: (972) 407-0639

U.S. Southeast

Phone: (770) 246-8283
Fax: (770) 246-0018

U.S. Southwest

Phone: (949) 222-9119
Fax: (949) 222-0620

APAC Headquarters

Conexant Systems Singapore,
Pte. Ltd.

1 Kim Seng Promenade
Great World City
#09-01 East Tower
Singapore 237994
Phone: (65) 737 7355
Fax: (65) 737 9077

Australia

Phone: (61 2) 9869 4088
Fax: (61 2) 9869 4077

China

Phone: (86 2) 6361 2515
Fax: (86 2) 6361 2516

Hong Kong

Phone: (852) 2827 0181
Fax: (852) 2827 6488

India

Phone: (91 11) 692 4780
Fax: (91 11) 692 4712

Korea

Phone: (82 2) 565 2880
Fax: (82 2) 565 1440

Europe Headquarters

Conexant Systems France
Les Taissounieres B1
1680 Route des Dolines
BP 283
06905 Sophia Antipolis Cedex
France
Phone: (33 4) 93 00 33 35
Fax: (33 4) 93 00 33 03

Europe Central

Phone: (49 89) 829 1320
Fax: (49 89) 834 2734

Europe Mediterranean

Phone: (39 02) 9317 9911
Fax: (39 02) 9317 9913

Europe North

Phone: (44 1344) 486 444
Fax: (44 1344) 486 555

Europe South

Phone: (33 1) 41 44 36 50
Fax: (33 1) 41 44 36 90

**Middle East
Headquarters**

Conexant Systems Commercial
(Israel) Ltd.
P. O. Box 12660
Herzlia 46733, Israel
Phone: (972 9) 952 4064
Fax: (972 9) 951 3924

Japan Headquarters

Conexant Systems Japan Co.,
Ltd.
Shimomoto Building
1-46-3 Hatsudai,
Shibuya-ku, Tokyo
151-0061 Japan
Phone: (81 3) 5371 1567
Fax: (81 3) 5371-1501

Taiwan Headquarters

Conexant Systems, Taiwan Co.,
Ltd.
Room 2808, 333
International Trade Building
Keelung Road, Section 1
Taipei 110, Taiwan, ROC
Phone: (886 2) 2720 0282
Fax: (886 2) 2757 6760