

SoftK56-PCI

Host-Software Processed V.90/K56flex™

Modem Device Family for Desktop Applications

Introduction

The Rockwell RS56-PCI (SoftK56) Host Software Processed V.90/K56flex™ Modem Device Family supports high speed analog data, 14.4 kbps fax, voice/TAM, and speakerphone (optional) operation. The modem operates with PSTN telephone lines in the U.S. and world-wide. Models are available in different packages with or without speakerphone support (see Table 1).

The SoftK56 modem family is available in three forms:

1. A single 144-pin thin quad flat pack (TQFP) that combines the PCI Bus Interface (BIF) and Line Codec (LC). This is the lowest cost device option. This device set also supports data/fax/voice/TAM with optional speakerphone using the Line/Voice Codec (LVC).
2. A 2-device set plug-compatible with Rockwell's RC56HCF-PCI host-controlled modem family. The two devices are the PCI Bus Interface in 176-pin TQFP and LVC in 144-pin TQFP. This device set supports data/fax/voice/TAM with optional speakerphone.
3. A 2-device set with a Line Codec (LC) in the smallest device footprint. The two devices are the PCI Bus Interface in 176-pin TQFP and LC in 32-pin TQFP. This device set supports data/fax/voice/TAM.

This device set is intended for application in PCI-based embedded motherboards, system boards, or plug-in cards designed for desktop use. Typical application block diagrams are illustrated in Figure 1.

Modem data pump and controller functions, traditionally enabled using dedicated hardware, are processed in a Pentium MMX-compatible CPU using host-signal processing modem software.

In ITU-T V.90/K56flex data mode, the modem can receive data at speeds up to 56 kbps from a digitally connected V.90 or K56flex-compatible central site modem. A V.90/K56flexmodem takes advantage of the PSTN which is primarily digital except for the client modem to central office local loop and are ideal for applications such as remote access to an Internet Service Provider (ISP), on-line service, or corporate site. In this mode, the modem can transmit data at speeds up to V.34 rates.

In V.34 data mode, the modem operates at line speeds up to 33.6 kbps. When applicable, error correction (V.42/MNP 2-4) and data compression (V.42 bis/MNP 5) maximize data transfer integrity and boost average data throughput. Non-error-correcting mode is also supported.

All models support remote audio recording and remote audio playback over the telephone line interface using A-Law, μ -Law, or linear coding at 8000 or 7200 Hz sample

rate to support applications such as digital telephone answering machine (TAM) and voice annotation.

SP models support position independent, full-duplex speakerphone (FDSP).

Fax Group 3 send and receive rates are supported up to 14.4 kbps with T.30 protocol.

V.80 synchronous access mode supports host-controlled communication protocols, e. g., H.324 video conferencing.

Reference design kits are available to minimize application design time and costs.

Features

- Data modem
 - ITU-T V.90, K56flex, V.34 (33.6 kbps), V.32 bis, V.32, V.22 bis, V.22, V.23, and V.21; Bell 212A and 103
 - V.42 LAPM and MNP 2-4 error correction
 - V.42 bis and MNP 5 data compression
 - V.250 (ex V.25 ter) and V.251 (ex V.25 ter Annex A) commands
- Fax modem send and receive rates up to 14.4 kbps
 - ITU-T V.17, V.29, V.27 ter, and V.21 channel 2
 - EIA/TIA 578 Class 1 and T.31 Class 1.0 commands
- Voice, telephony, TAM
 - V.253 commands
 - 8-bit μ -Law/A-Law coding (G.711)
 - 8-bit/16-bit linear coding
 - 8000/7200 Hz sample rate
 - Music on hold from host or analog hardware input
 - TAM support with concurrent DTMF detect, ring detect and caller ID
- V.80 synchronous access mode supports host-controlled communication protocols
 - H.324 interface support
- V.8/V.8bis and V.251 (ex V.25 ter Annex A) commands
- Speakerphone model (optional)
 - Telephone handset interface
 - External microphone and speaker interface
- Full-duplex Speakerphone (FDSP) Mode (SP model)
 - Microphone gain and muting
 - Speaker volume control and muting
 - Adaptive acoustic, line, and handset echo cancellation
 - Loop gain control, transmit and receive path AGC
 - Switching to/from data and fax
- Data/Fax/Voice call discrimination
- Multiple country support
 - Call progress, blacklisting
- Single profile stored in host
- Modem and audio paths concurrent across PCI bus

Features (Continued)

- System compatibilities
 - Windows 95, Windows 95 OSR2, Windows 98, Windows NT 4.0, Windows NT 5.0 operating systems
 - Microsoft's PC 98 Design Initiative compliant
 - Unimodem/V compliant
- 32-bit PCI Local Bus interface
 - Conforms to the PCI Local Bus Specification, Production Version, Revision 2.1
 - PCI Bus Mastering interface to the LVC
 - 33 MHz PCI clock support
- Supports PCI Bus Power Management
 - Conforms to PCI Bus Power Management Specification, Rev. 1.1
 - ACPI Power Management Registers
 - PME# and APM support
- Device packages:
 - BIF and LVC in a single 144-pin TQFP
 - BIF in 176-pin TQFP and LC in 32-pin TQFP
 - BIF in 176-pin TQFP and LVC in 144-pin TQFP
- +3.3V operation with +5V tolerant digital inputs
- +5V (recommended) or +3.3V analog operation

Table 1. Modem Models and Functions

Single Device Models in 144-Pin TQFP - with or without Speakerphone Capability					
Model/Order/Part Numbers			Supported Functions		
Marketing Model Number ¹	Device Set Order Number	Combined PCI Bus Interface (BIF) and Line/Voice Codec (LVC) or Line Codec (LC) Part No.		V.90 and K56flex Data, Voice/TAM, V.17 Fax	FDSP
RS56-PCI	DS56-L480-041	R6793-12 (BIF + LC)		Y	–
RS56/SP-PCI	DS56-L480-031	R6793-11 (BIF + LVC)		Y	Y
Two Device Models in 176-Pin TQFP and 32-Pin TQFP - RC56HCF-PCI Pin Compatible without Speakerphone Capability					
Model/Order/Part Numbers				Supported Functions	
Marketing Model Number ¹	Device Set Order Number	PCI Bus Interface (BIF) 176-Pin TQFP Part No.	Line Codec (LC) 32-Pin TQFP Part No.	V.90 and K56flex Data, Voice/TAM, V.17 Fax	FDSP
RS56-PCI	DS56-L482-031	11235-14	20437-11	Y	–
Two Device Models in 176-Pin TQFP and 144-Pin TQFP - RC56HCF-PCI Pin Compatible with Speakerphone Capability					
Model/Order/Part Numbers				Supported Functions	
Marketing Model Number ¹	Device Set Order Number	PCI Bus Interface (BIF) 176-Pin TQFP Part No.	Line/Voice Codec (LVC) 144-Pin TQFP Part No.	V.90 and K56flex Data, Voice/TAM, V.17 Fax	FDSP
RS56/SP-PCI	DS56-L481-061	11235-14	20410-14	Y	Y
Notes:					
1. Model options:					
SP		Speakerphone			
2. Supported functions (Y = Supported; – = Not supported):					
FDSP		Full-duplex speakerphone			
Voice/TAM		Voice and telephone answering machine			

K56flex is a trademark of Rockwell International and Lucent Technologies.
MNP is a trademark of Compaq Computer Corporation.
Microsoft and Windows are registered trademarks of Microsoft Corporation.



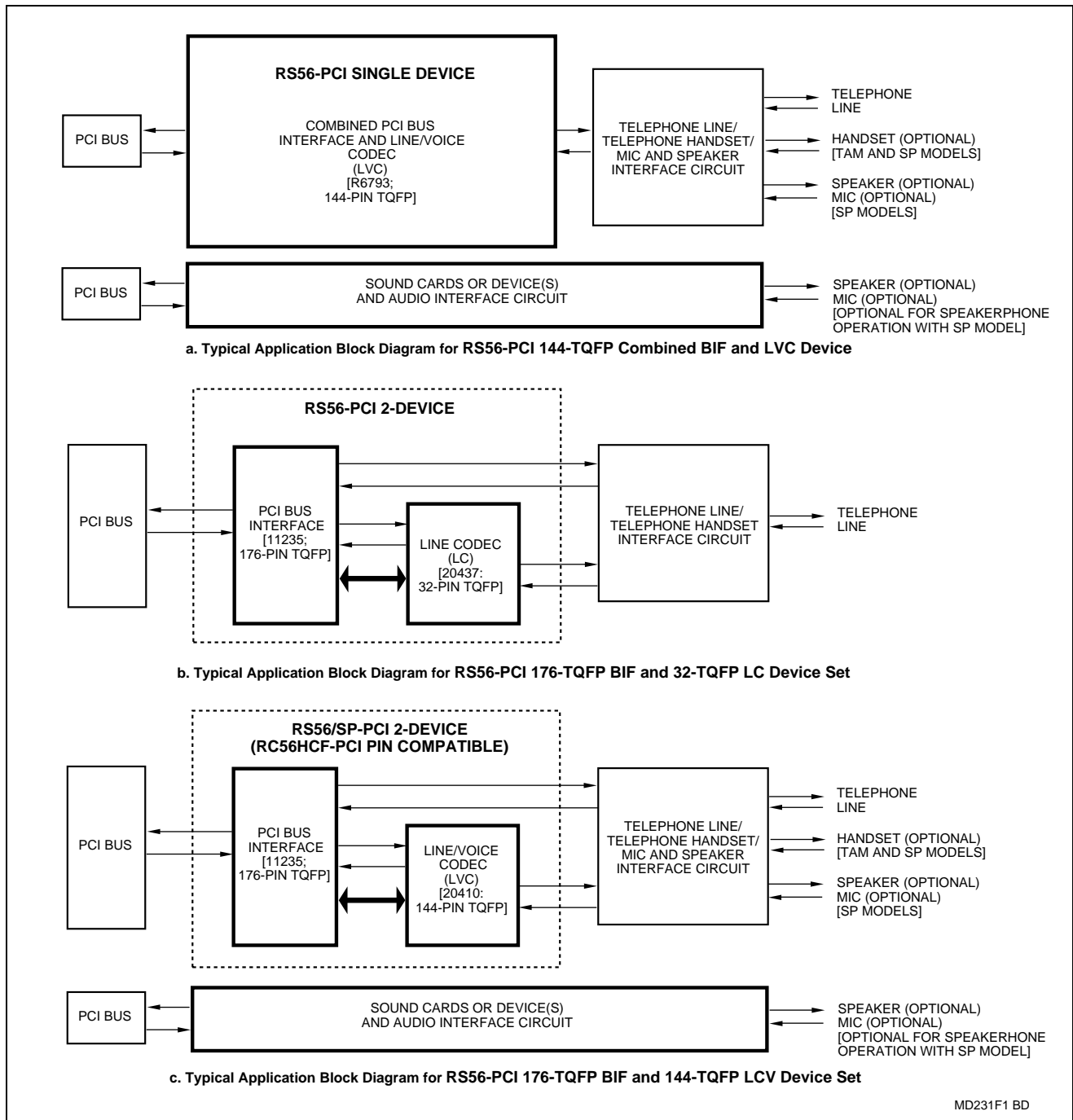

Figure 1. RS56-PCI Configuration Block Diagrams

Description

General

The RS56-PCI Device Sets provide the processing core for a complete system design featuring data/fax modem, voice/TAM, and speakerphone depending on specific model (Table 1).

Note: The term, "SoftK56", refers to the family of modem models listed in Table 1.

The modem is the full-featured, self-contained data modem, fax modem, voice/TAM, and speakerphone (optional) solution. These functions, as well as dialing, call progress, telephone line interface and host interface functions are supported and controlled through the command set.

The modem hardware connects to the host PC via a PCI bus interface. The OEM adds a crystal circuit, telephone line interface, telephone interface (optional), and audio interface (optional) to complete the system.

Host-Processed Modem Software

The host-processed modem software performs two distinct tasks:

1. General modem control, which includes command sets, fax Class 1, voice/TAM, speakerphone, error correction, data compression, and operating system interface functions.
2. Modem data pump signal processing, which includes data and facsimile modulation and demodulation, as well as voice sample formatting.

Configurations of the modem software are provided to support modem models listed in Table 1.

Binary executable modem software is provided for the OEM.

Data/Fax Modes

As a V.90/K56flex data modem, the modem can receive data from a digital source using a V.90- or K56flex-compatible central site modem over the digital telephone network portion of the PSTN at line speeds up to 56 kbps. Asymmetrical data transmission supports sending data up to V.34 rates. This mode can fallback to full-duplex V.34 mode, and to slower rates as dictated by line conditions.

As a V.34 data modem, the modem can operate in 2-wire, full-duplex, asynchronous modes at line rates up to 33.6 kbps. Data modem modes perform complete handshake and data rate negotiations. Using V.34 modulation to optimize modem configuration for line conditions, the modem can connect at the highest data rate that the channel can support from 33600 bps down to 2400 bps with automatic fallback. Automode operation in V.34 is provided in accordance with PN3320 and in V.32 bis in accordance with PN2330. All tone and pattern detection functions required by the applicable ITU or Bell standard are supported.

In fax modem mode, the modem can operate in 2-wire, half-duplex, synchronous modes and can support Group 3 facsimile send and receive speeds of 14400, 12000, 9600, 7200, 4800, or 2400 bps. Fax data transmission

and reception performed by the modem are controlled and monitored through the fax EIA/IA-578 Class 1 and T.31 Class 1.0 command interface. Full HDLC formatting, zero insertion/deletion, and CRC generation/checking are provided.

Synchronous Access Mode (SAM) - Video Conferencing

V.80 synchronous access mode between the modem and the host/DTE is provided for host-controlled communication protocols, e.g., H.324 video conferencing applications.

Voice-call-first (VCF) before switching to a videophone call is also supported.

Voice/TAM Mode

Voice/TAM Mode features include 8-bit μ -Law, A-Law, and linear coding at 8000 Hz and 7200 Hz sample rates. Tone detection/generation, call discrimination, and concurrent DTMF detection are also supported. ADPCM coding is also supported to meet Microsoft WHQL logo requirements.

Voice/TAM Mode is supported by three submodes:

1. Online Voice Command Mode supports connection to the telephone line or, for SP models, a handset.
2. Voice Receive Mode supports recording voice or audio data input at the RIN pin, typically from the telephone line or, for SP models, a microphone/handset.
3. Voice Transmit Mode supports playback of voice or audio data to the TXA1/TXA2 output, typically to the telephone line or, for SP models, a speaker/handset.

Speakerphone Mode (SP Models)

The SP model includes an additional telephone handset, external microphone, and external speaker interface which supports voice and full-duplex speakerphone (FDSP) operation. The Speakerphone Mode features an advanced proprietary speakerphone algorithm which supports full-duplex voice conversation with acoustic, line, and handset echo cancellation. Parameters are constantly adjusted to maintain stability with automatic fallback from full-duplex to pseudo-duplex operation. The speakerphone algorithm allows position independent placement of microphone and speaker.

The speakerphone mode provides hands-free full-duplex telephone operation under host control. The host can separately control volume, muting, and AGC in microphone and speaker channels.

The speakerphone mode also supports Voice/TAM Mode connection to a handset.

Hardware Interface Signals

The major functional interface signals are shown in Figure 2.

Bus Interface and Codec (BIC) Interface

The BIC (R6793) 144-pin TQFP hardware interface signals are shown in Figure 3.

The BIC (R6793) 144-pin TQFP pin assignments are shown in Figure 4.

Bus Interface (BIF) Interface

The BIF (11235) 176-pin TQFP hardware interface signals are shown in Figure 5.

The BIF (11235) 176-pin TQFP pin assignments are shown in Figure 6.

Line/Voice Codec (LVC) Interface

The LVC (20410) 144-pin TQFP hardware interface signals are shown in Figure 7.

The LVC (20410) 144-pin TQFP pin assignments are shown in Figure 8.

Line Codec (LC) Interface

The LC (20437) 32-pin TQFP hardware interface signals are shown in Figure 9.

The LC (20437) 32-pin TQFP pin assignments are shown in Figure 10.

Package Dimensions

The package dimensions are shown in Figure 11 (176-pin TQFP), Figure 12 (144-pin TQFP), and Figure 13 (32-pin TQFP).

Electrical and Environmental Specifications

The current and power requirements are listed in Table 2.

The absolute maximum ratings are listed in Table 3.

Additional Information

Additional information is described in the SoftK56-PCI Designer's Guide (Order No. 1201) and in the Command Reference Manual (Order No. 1163).

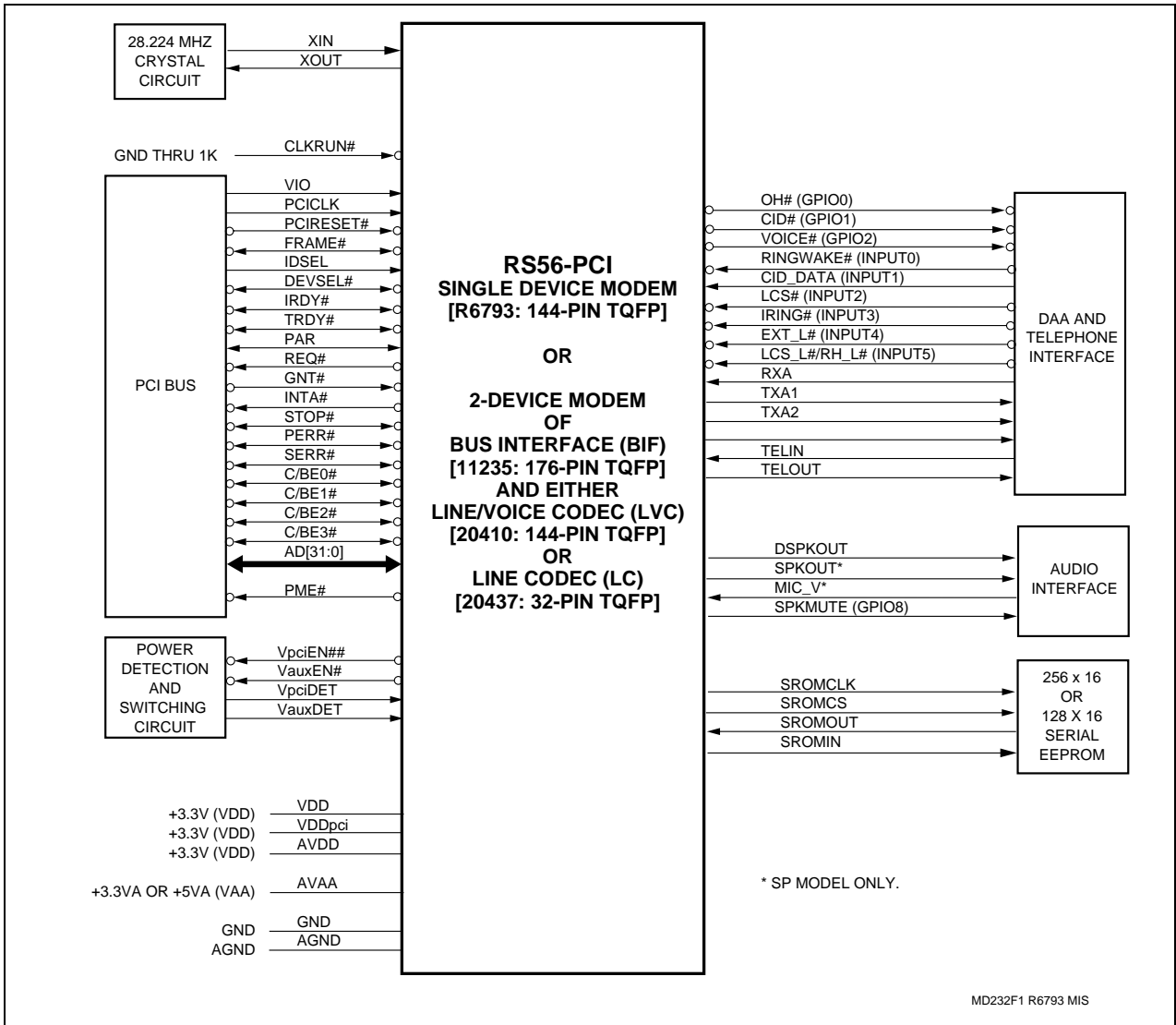

Figure 2. RS56-PCI Major Interface Signals

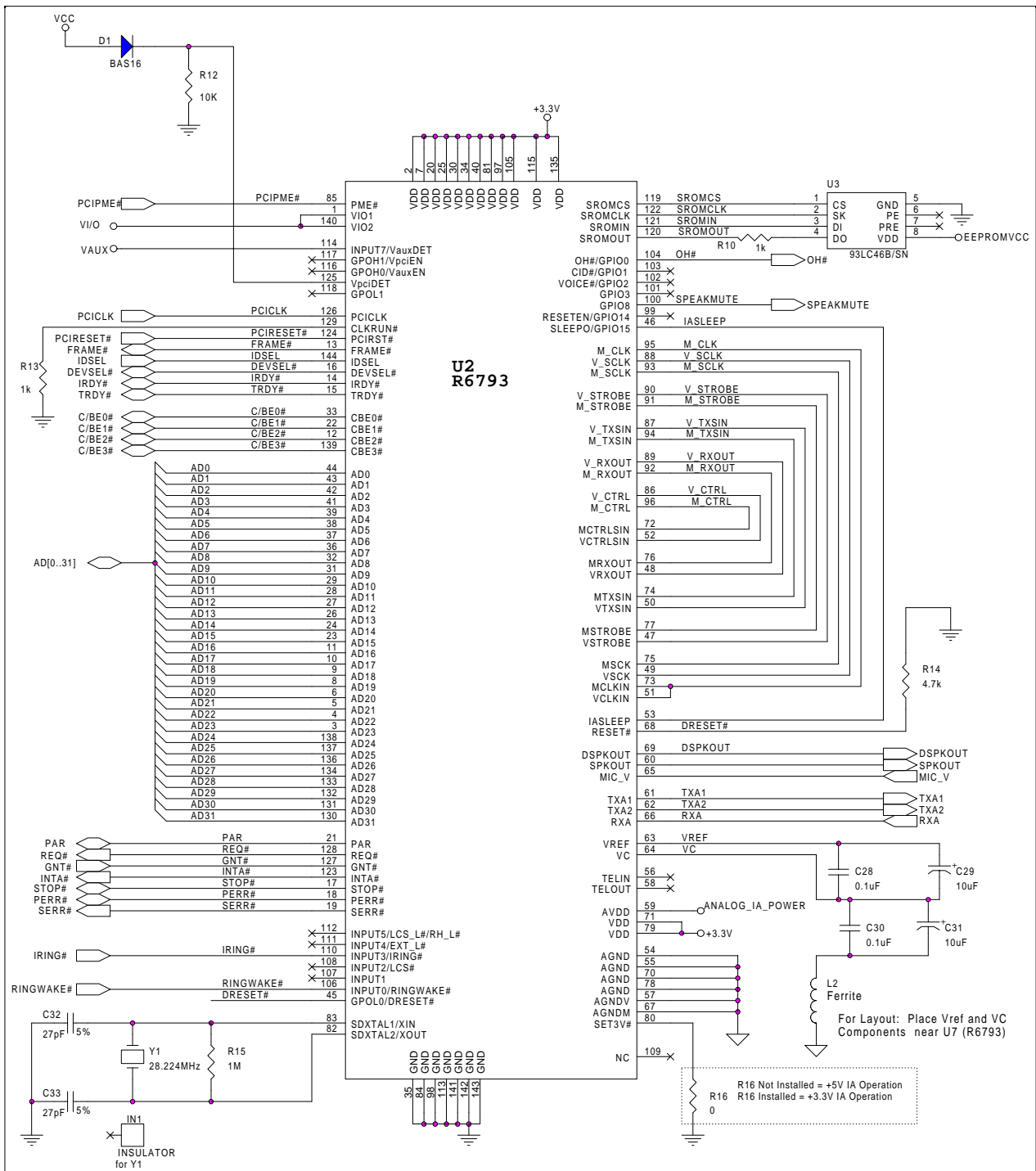

Figure 3. Bus Interface/Codec (BIC) (R6793: 144-Pin TQFP) Hardware Interface Signals

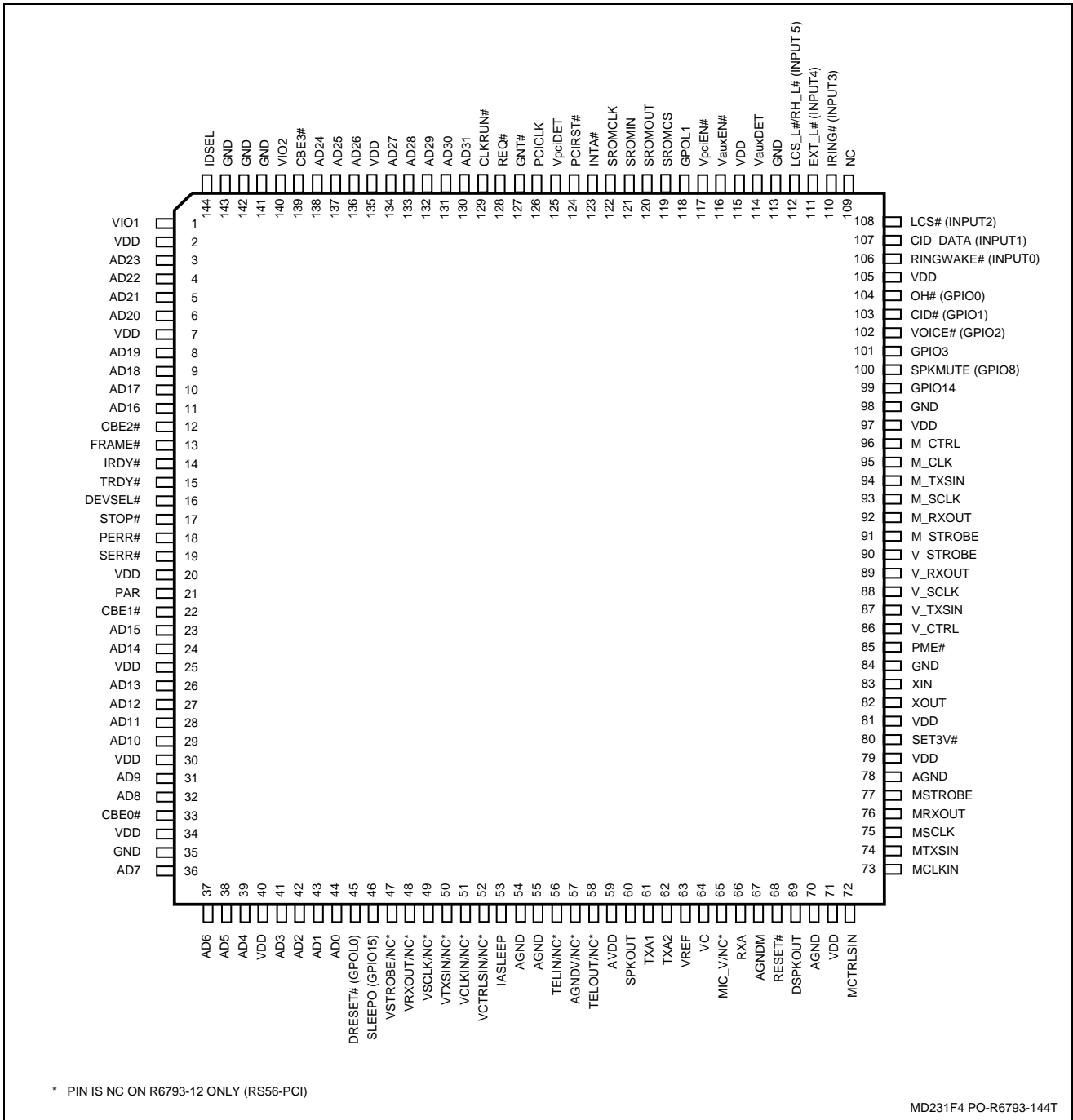

Figure 4. BIC (R6793: 144-Pin TQFP) Pin Signals

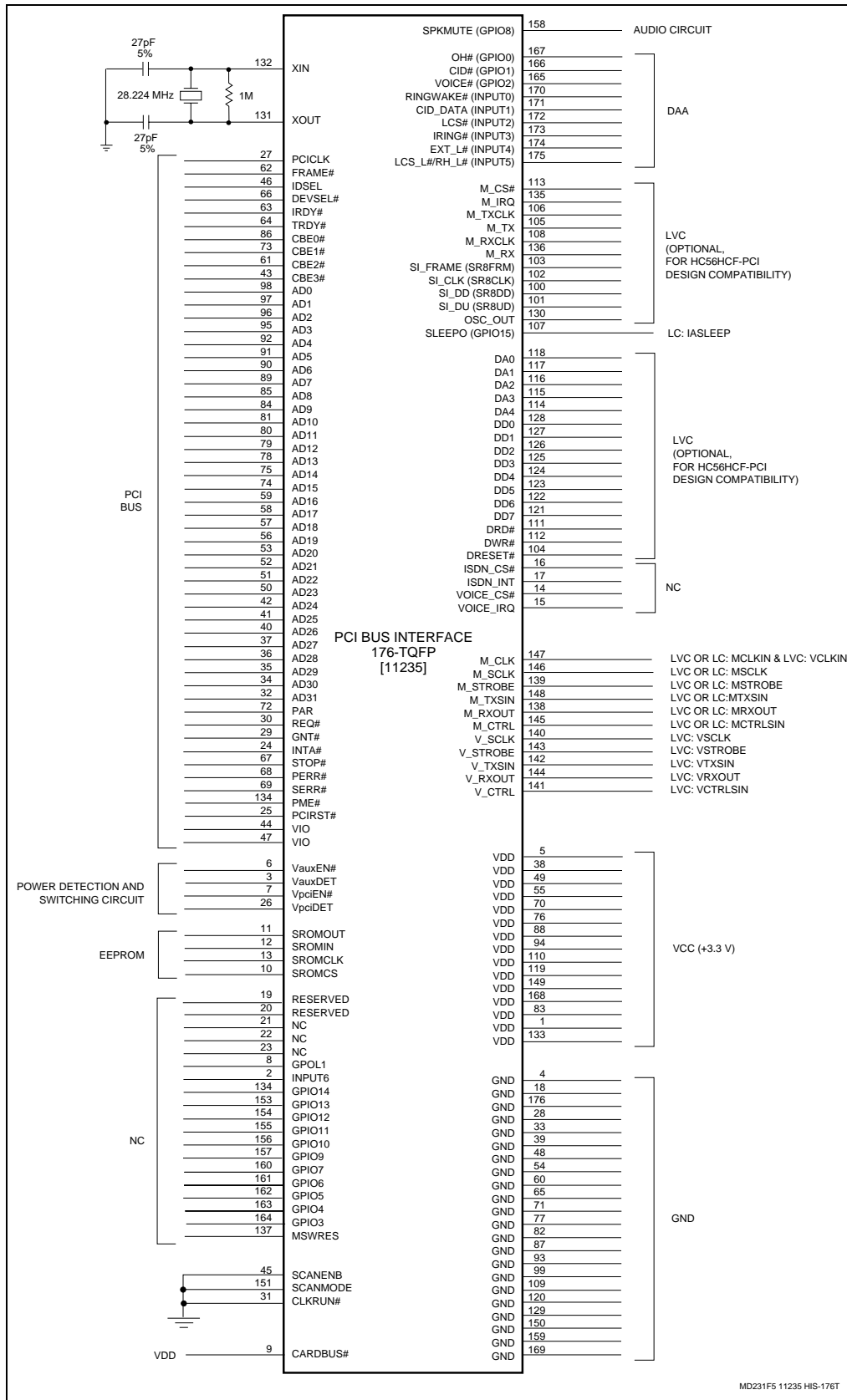

Figure 5. Bus Interface (BIF) (11235: 176-Pin TQFP) Hardware Interface Signals

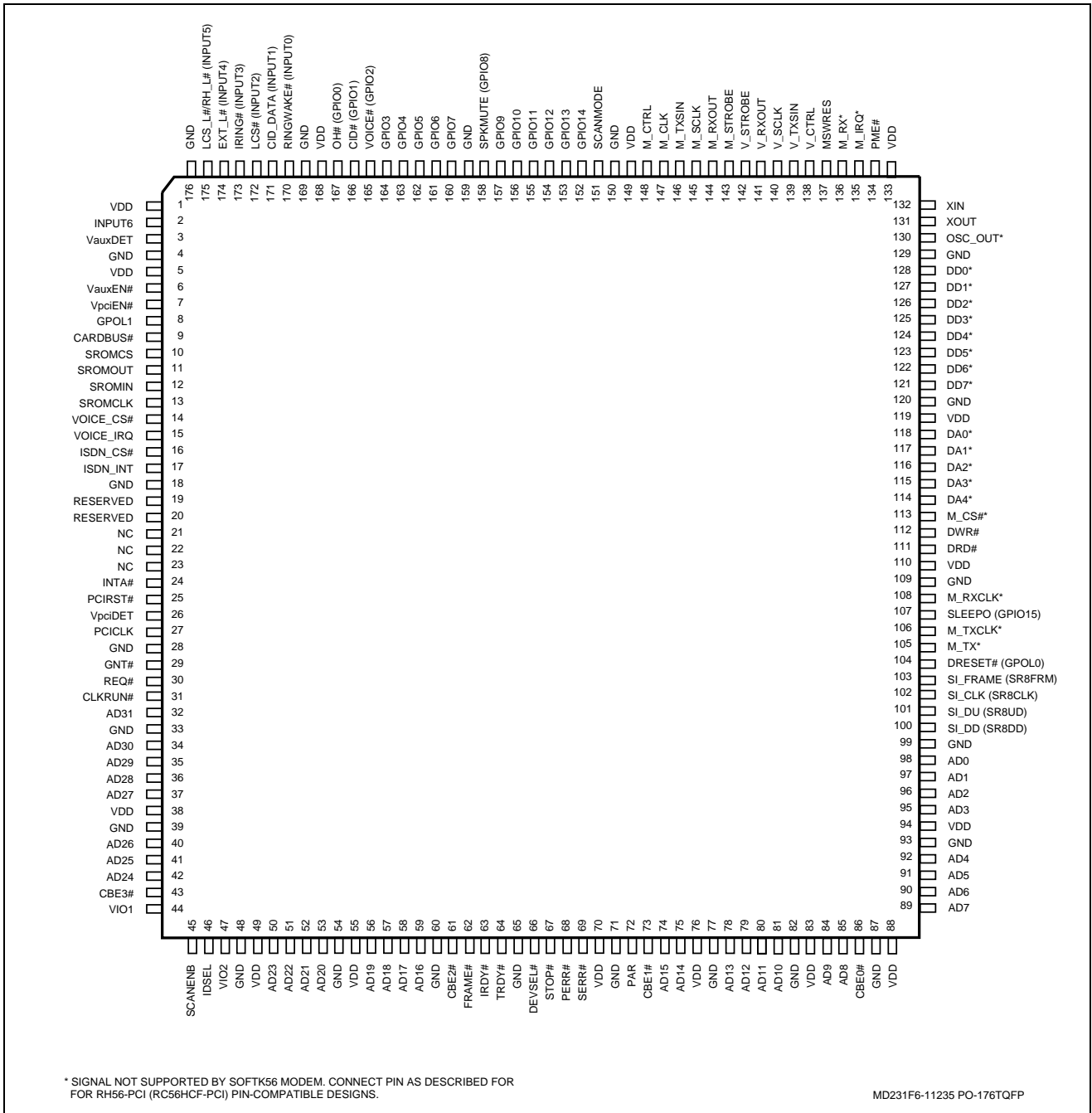

Figure 6. BIF (11235: 176-Pin TQFP) Pin Signals

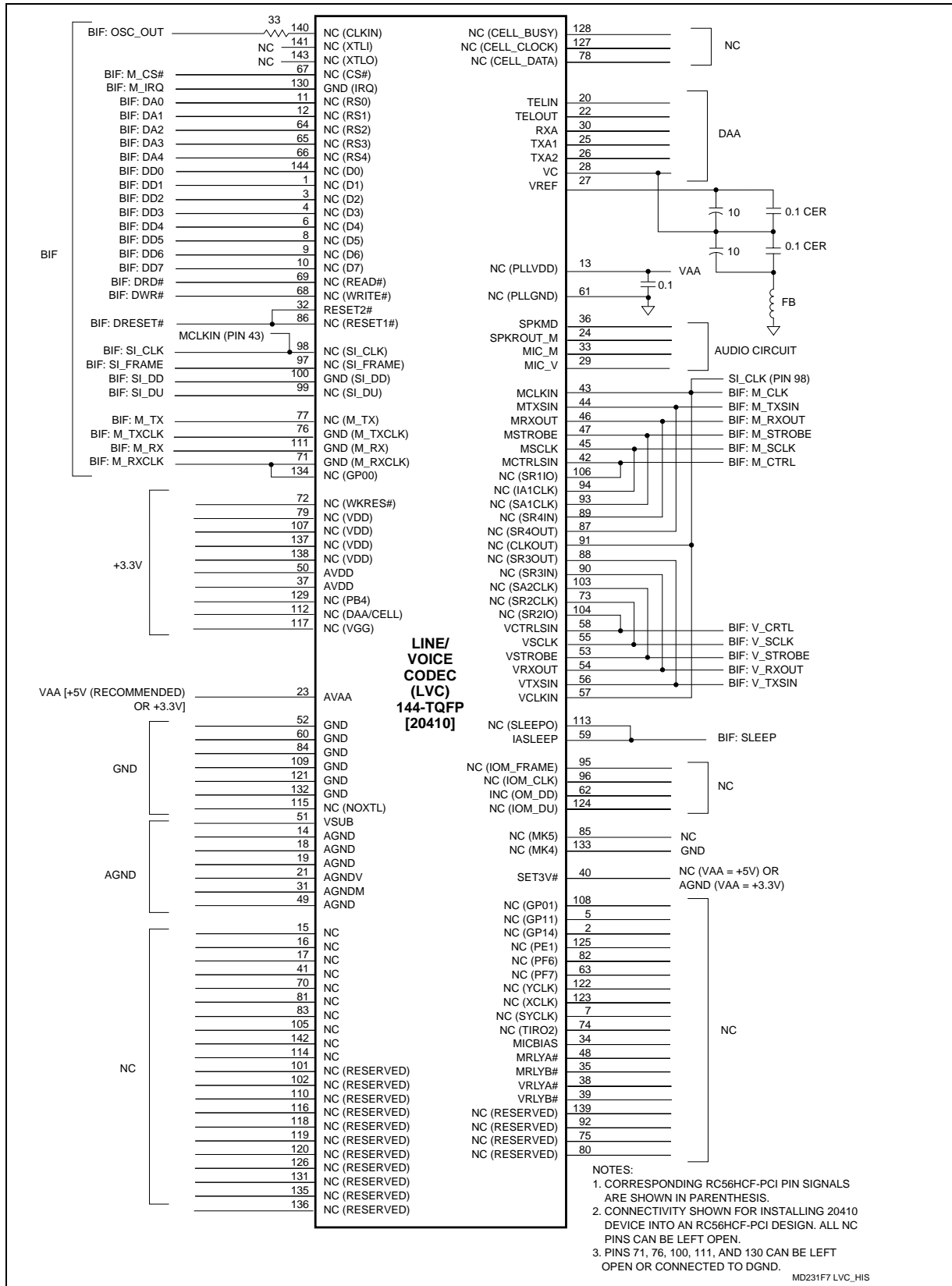

Figure 7. Line/Voice Codec (LVC) (20410: 144-Pin TQFP) Hardware Interface Signals

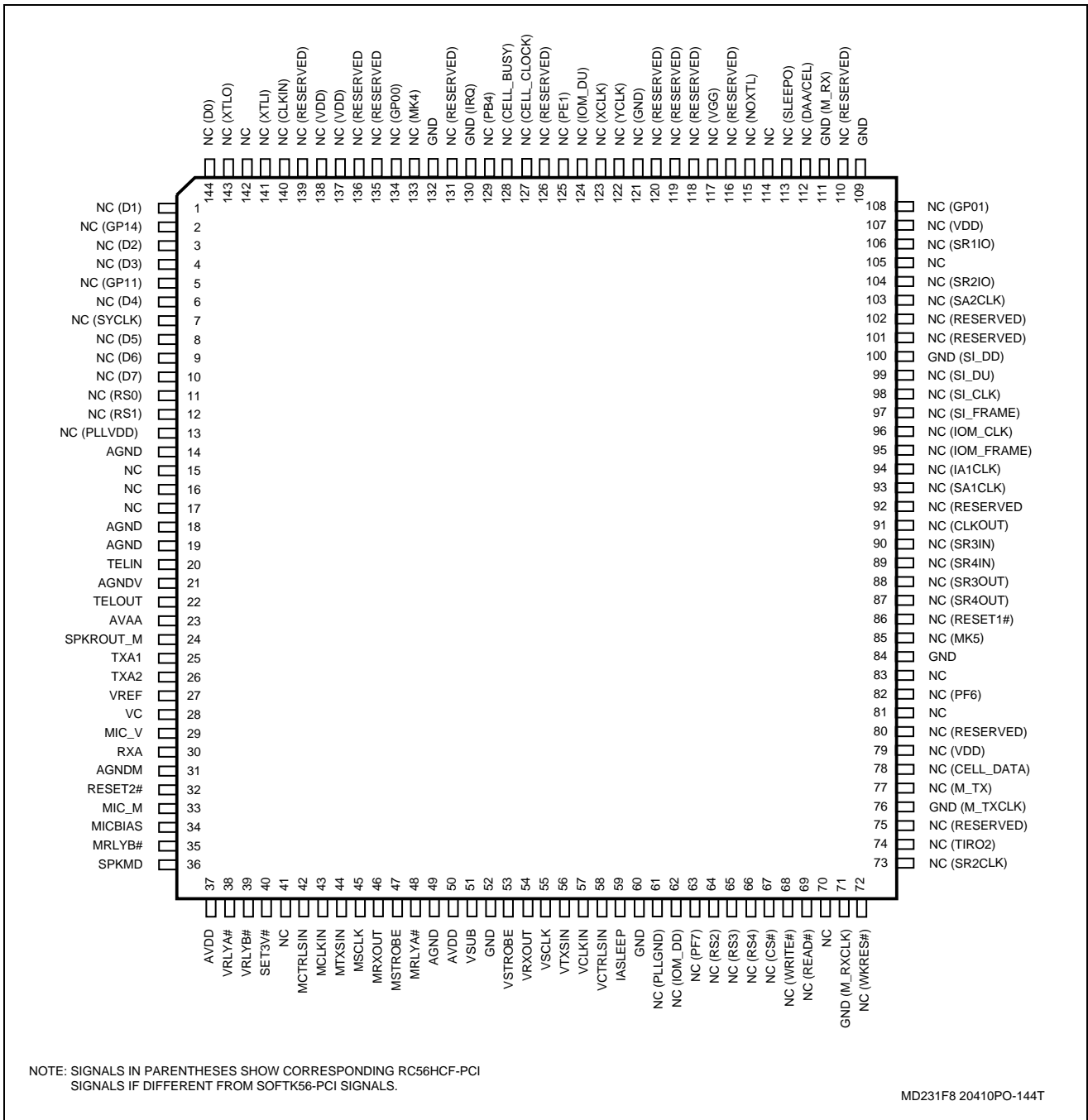

Figure 8. LVC (20410: 144-Pin TQFP) Pin Signals

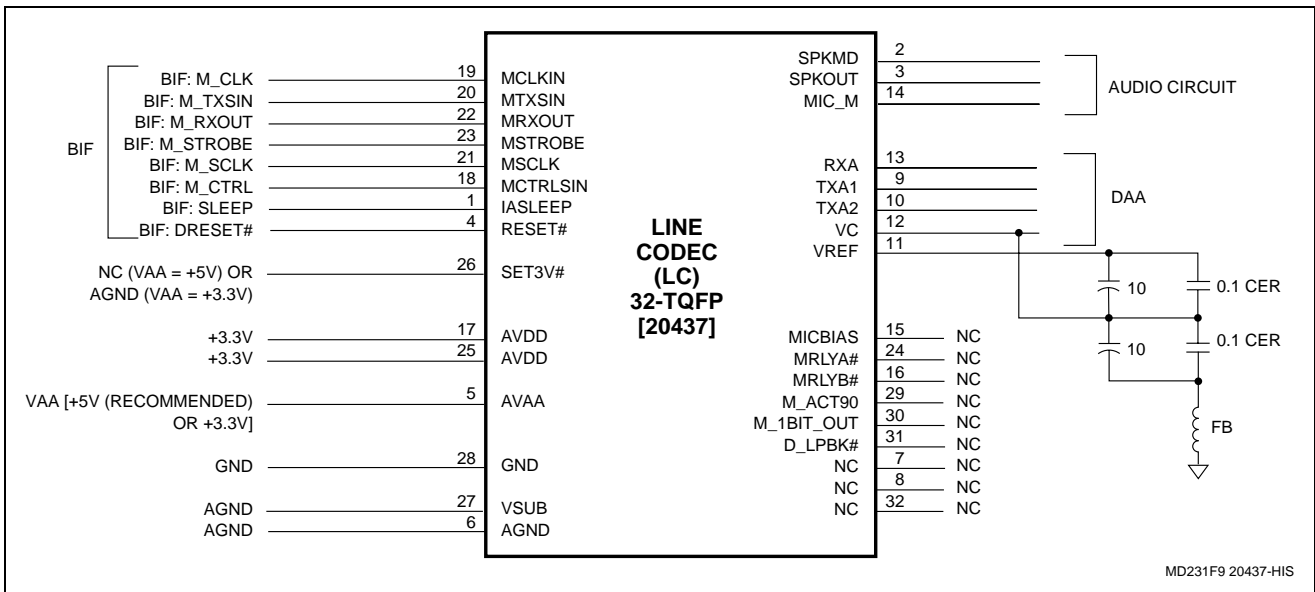

Figure 9. Line Codec (LC) (20437: 32-Pin TQFP) Hardware Interface Signals

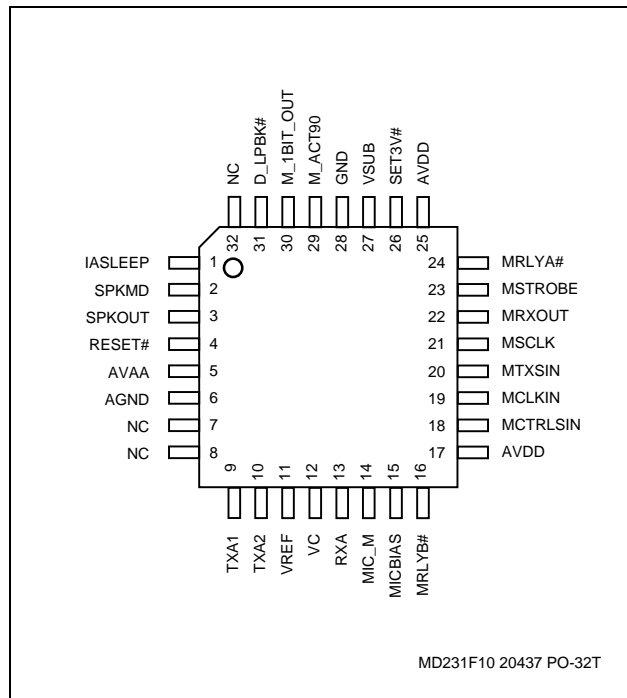

Figure 10. LC (20437: 32-Pin TQFP) Pin Signals

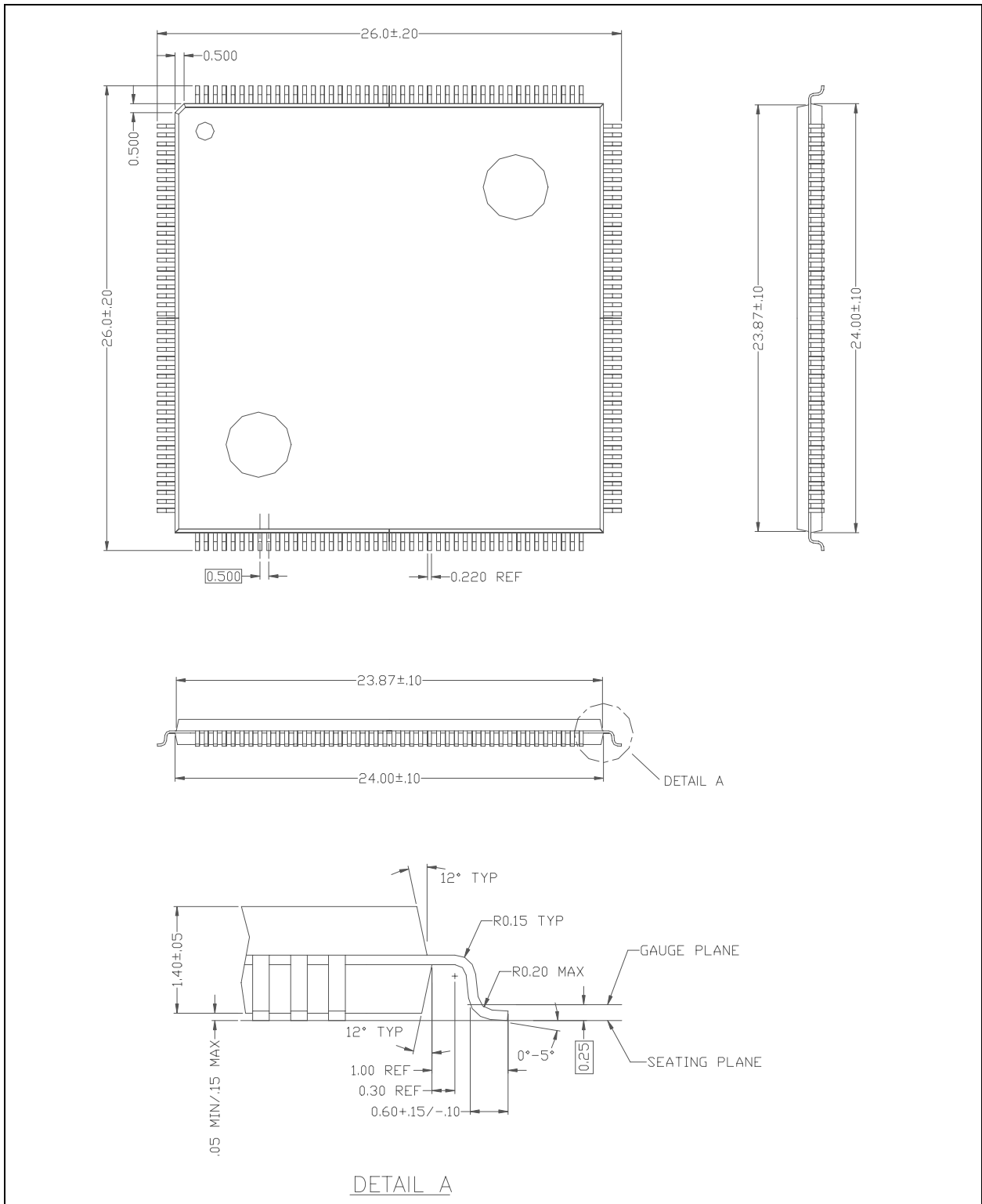

Figure 11. Package Dimensions - 176-Pin TQFP

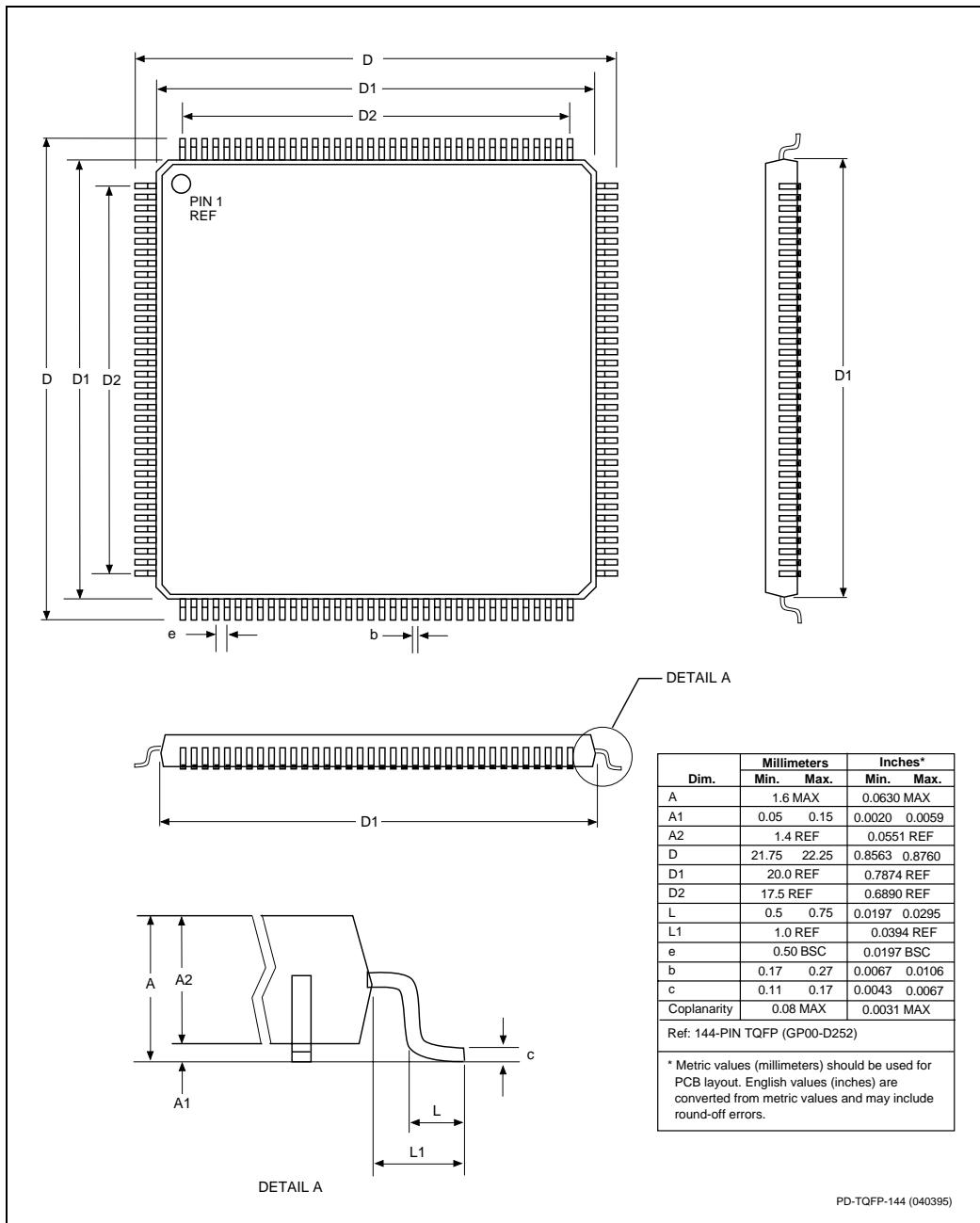

Figure 12. Package Dimensions - 144-Pin TQFP

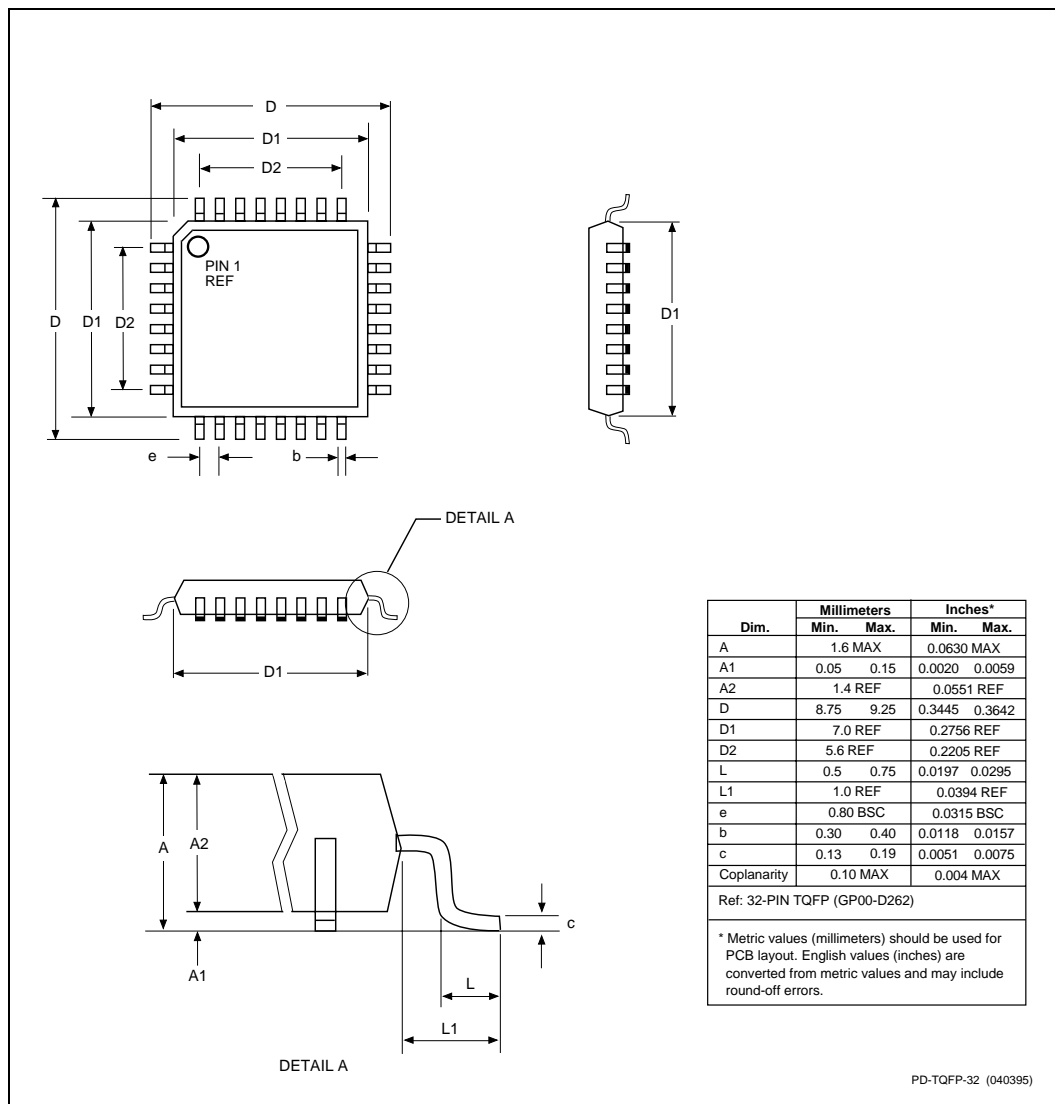

Figure 13. Package Dimensions - 32-Pin TQFP

Table 2. Current and Power Requirements

Device State (Dx) and Bus State (Bx)	Conditions			Current		Power	
	PCI Bus Power	PCI Clock (PCICLK)	Line Connection	Typical Current (mA)	Maximum Current (mA)	Typical Power (mW)	Maximum Power (mW)
Single Device (R6793-12 BIC) and 2-Device Set (11235-14 BIF and 20437-11 LC)							
D0, B0	On	Running	Yes	33	36	109	130
D0, B0	On	Running	No	22	24	73	86
D3, B0	On	Running	No	22	24	73	86
D3, B1	On	Running	No	22	24	73	86
D3, B2, B3 (D3 hot)	On	Stopped	No	2.1	3.2	6.9	11.5
D3, B3 (D3 cold)	Off	Stopped	No	<1	1	<3.3	3.6
Single Device (R6793-11 BIC) and 2-Device Set (11235-14 BIF and 20410-11 LVC)							
D0, B0	On	Running	Yes	33	36	109	130
D0, B0	On	Running	No	22	24	73	86
D3, B0	On	Running	No	22	24	73	86
D3, B1	On	Running	No	22	24	73	86
D3, B2, B3 (D3 hot)	On	Stopped	No	2.1	3.2	6.9	11.5
D3, B3 (D3 cold)	Off	Stopped	No	<1	1	<3.3	3.6
Notes:							
Operating voltage: VDD = +3.3V ± 0.3V.							
Test conditions: VDD = +3.3 VDC for typical values; VDD = +3.6 VDC for maximum values.							
For all modes, +3.3V is supplied to BIF and LVC and LC.							
Definitions:							
PCI Bus Power	On: PCI Bus +5V and +3.3V on (modem normally powered by +3.3V from PCI Bus +3.3V or regulated down from PCI Bus +5V); PCI RST# not asserted. Off: PCI Bus +5V and +3.3V off (modem normally powered by +3.3V from Vaux or Vpci); PCI RST# asserted.						
PCI Clock (PCICLK)	Running: PCI Bus signal PCICLK running; Stopped: PCI Bus signal PCICLK stopped (off).						
Line connection:	Yes: Off-hook, IA powered. No: On-hook, IA powered down.						
Device States:	D3: Low power state. Suspend state can change the system power state; the resulting power state depends on the system architecture (OS, BIOS, hardware) and system configuration (i.e., other PCI installed cards). D0: Full power state.						
Device and Bus States:	D0, B0: Any PCI transaction, PCICLK running, VCC present. D3, B1: No PCI Bus transactions, PCICLK running, VCC present. D3, B2, B3: No PCI transactions, PCICLK stopped, VCC may be present. D3, B3: No PCI transactions, PCICLK stopped, no VCC.						
Refer to the PCI Bus Power Management Interface Specification for additional information.							

Table 3. Absolute Maximum Ratings

Parameter	Symbol	Limits	Units
Supply Voltage	V_{DD}	-0.5 to +4.0	V
Input Voltage	V_{IN}	-0.5 to (VDD +0.5) (BIF) -0.5 to (VGG +0.5)* (LVC)	V
Operating Temperature Range	T_A	-0 to +70	°C
Storage Temperature Range	T_{STG}	-55 to +125	°C
Analog Inputs	V_{IN}	-0.3 to (VAA + 0.5)	V
Voltage Applied to Outputs in High Impedance (Off) State	V_{HZ}	-0.5 to (VDD +0.5) (BIF) -0.5 to (VGG +0.5)* (LVC)	V
DC Input Clamp Current	I_{IK}	±20	mA
DC Output Clamp Current	I_{OK}	±20	mA
Static Discharge Voltage (25°C)	V_{ESD}	±2500	V
Latch-up Current (25°C)	I_{TRIG}	±400	mA
* VGG = 5.0V ± 0.25V or +3.3V ± 0.3V.			

NOTES

Information provided by Rockwell International Corporation is believed to be accurate and reliable. However, no responsibility is assumed by Rockwell International for its use, nor any infringement of patents or other rights of third parties which may result from its use. No license is granted by implication or otherwise under any patent rights of Rockwell International other than for circuitry embodied in Rockwell products. Rockwell International reserves the right to change circuitry at any time without notice. This document is subject to change without notice.

Worldwide Headquarters

Rockwell Semiconductor Systems
4311 Jamboree Road,
P.O. Box C
Newport Beach, CA 92658-8902
Phone: (949) 221-4600
Fax: (949) 221-6375

For more information:
Call 1-800-854-8099
International information:
Call 1-949-221-6996

URL Address:
<http://www.rss.rockwell.com>
E-Mail Address:
literature@rss.rockwell.com

REGIONAL SALES OFFICES**US Northwest/Pacific Northwest**

Rockwell Semiconductor Systems
US Northwest Office
3600 Pruneridge Avenue
Suite 100
Santa Clara, CA 95051
Phone: (408) 249-9696
Fax: (408) 249-7113

US Los Angeles

Rockwell Semiconductor Systems
1000 Business Center Circle
Suite 215
Thousand Oaks, CA 91320
Phone: (805) 376-0559
Fax: (805) 376-8180

US Southwest

Rockwell Semiconductor Systems
5000 Birch Street
Suite 400
Newport Beach, CA 92660
Phone: (949) 222-9119
Fax: (949) 222-0620

US North Central

Rockwell Semiconductor Systems
Two Pierce Place
Chancellory Park
Suite 810
Itasca, IL 60143
Phone: (630) 773-3454
Fax: (630) 773-3907

US South Central

Rockwell Semiconductor Systems
17304 Preston Road
Suite 970
Dallas, TX 75252
Phone: (972) 733-0723
Fax: (972) 407-0639

US Northeast

Rockwell Semiconductor Systems
239 Littleton Road
Suite 4A
Westford, MA 01886
Phone: (508) 692-7660
Fax: (508) 692-8185

US Southeast

Rockwell Semiconductor Systems
3500 Parkway Lane, Suite 415
Norcross, GA 30092
Phone: (770) 246-8283
Fax: (770) 246-0018

US Florida/South America

Rockwell Semiconductor Systems
One Prestige Place
2600 McCormick Drive
Suite 350
Clearwater, FL 33759
Phone: (813) 799-8406
Fax: (813) 799-8306

US Mid-Atlantic

Rockwell Semiconductor Systems
Princeton Pike Corporate Center
993 Lenox Drive, Suite 200
Lawrenceville, NJ 08648
Phone: (609) 219-7462
Fax: (609) 895-2666

European Headquarters

Rockwell Semiconductor Systems
S.A.S.
Les Taissounieres B1
1680 Route des Dolines
BP 283
06905 Sophia Antipolis Cedex
France
Phone: (33) 4 93 00 33 35
Fax: (33) 4 93 00 33 03

Europe Central

Rockwell Int'l GmbH,
Rockwell Semiconductor Systems
Branch
Paul-Gerhardt-Allee 50 a
81245 München
Germany
Phone: (49-89) 829-1320
Fax: (49-89) 834-2734

Europe Mediterranean

Rockwell Semiconductor Systems
c/o Rockwell Automation S.r.l.
Via G. Di Vittorio, 1
20017 Mazzo Di Rho (MI)
Italy
Phone: (39 2) 93179911
Fax: (39 2) 93179913

Europe North

Rockwell Semiconductor Systems, Ltd.
Berkshire Court
Western Road
Bracknell
Berkshire RG12 1RE
England
Phone: 44 (0) 1344 486444
Fax: 44 (0) 1344 486555

Europe North (Satellite)

Rockwell Semiconductor Systems
Israel, Ltd. (RSSI)
11 Galgaley Haplada Street
P.O. Box 12660
Herzlia 46733
Israel
Phone: (972) 9 9524000
Fax: (972) 9 9573732

Europe South

Rockwell Semiconductor Systems
S.A.S.
Tour GAN
Cedex 13
92082 Paris La Défense 2
France
Phone: (33) 1 49 06 39 80
Fax: (33) 1 49 06 39 90

APAC Headquarters

Rockwell Int'l Manufacturing Pte Ltd
1 Kim Seng Promenade
#09-01 East Tower
Great World City
Singapore 237994
Phone: (65) 737-7355
Fax: (65) 737-9077

Australia

Rockwell Australia Pty Limited
Suite 603, 51 Rawson Street
Epping, NSW 2121
Australia
Phone: (61-2) 9869 4088
Fax: (61-2) 9869 4077

China

Rockwell Semiconductor Systems
Worldwide, Inc.
Shanghai Representative Office
LT Square Building, Suite 3002
500 Chengdu North Road
Shanghai 200003 P.R.C.
Phone: 86-21-6361-2515
Fax: 86-21-6361-2516

Hong Kong

Rockwell Int'l (Asia Pacific) Ltd.
13th Floor, Suites 8-10,
Harbour Centre
25 Harbour Road
Wanchai,
Hong Kong
Phone: (852) 2 827-0181
Fax: (852) 2 827-6488

India

Rockwell Int'l Overseas Corporation
Regional Office - South Asia
Capital Trust House
47 Community Centre
Friends Colony
New Delhi - 110 065
India
Phone: (91-11) 692-4780
Fax: (91-11) 692-4712

Korea

Rockwell Collins Int'l, Inc.
Room No. 1508
Korea Textile Centre Building
944-31, Daechi-3dong
Kangnam P.O. Box 2037
Kangnam-ku
Seoul
Korea
Phone: (82-2) 565-2880
Fax: (82-2) 565-1440

Taiwan Headquarters

Rockwell Int'l Taiwan Company, Ltd.
Room 2808 International Trade Bldg.
333, Keelung Road, Section I
Taipei,
Taiwan
10548 ROC
Phone: (886-2) 2720-0282
Fax: (886-2) 2757-6760

Japan Headquarters

Rockwell Int'l Japan Co., Ltd.
Shimomoto Bldg
1-46-3 Hatsudai, Shibuya-ku
Tokyo, 151
Japan
Phone: (81-3) 5371 1520
Fax: (81-3) 5371 1501

SOUND980623