



# CAT25CXXX

Supervisory Circuits with SPI Serial E<sup>2</sup>PROM, Precision Reset Controller and Watchdog Timer

## FEATURES

- 10 MHz SPI Compatible
- 1.8 to 6.0 Volt Operation
- Hardware and Software Protection
- Zero Standby Current
- Low Power CMOS Technology
- SPI Modes (0,0 & 1,1)
- Commercial, Industrial and Automotive Temperature Ranges
- Active High or Low Reset Outputs
  - Precision Power Supply Voltage Monitoring
  - 5V, 3.3V, 3V and 1.8V Options
- Watchdog Timer on  $\overline{CS}$
- 1,000,000 Program/Erase Cycles
- 100 Year Data Retention
- Self-Timed Write Cycle
- 8-Pin DIP/SOIC, 16-Pin SOIC and 14-Pin TSSOP
- Page Write Buffer
- Block Write Protection
  - Protect 1/4, 1/2 or all of E<sup>2</sup>PROM Array
- Programmable Watchdog Timer
- Built-in inadvertent Write Protection
  - V<sub>CC</sub> Lock Out

## DESCRIPTION

The CAT25CXXX is a single chip solution to three popular functions of EEPROM Memory, precision reset controller and watchdog timer. The EEPROM Memory is a 2K/4K/8K/16K/32K-Bit SPI Serial CMOS E<sup>2</sup>PROM internally organized as 256x8/512x8/1024x8/2048x8/4096x8 bits. Catalyst's advanced CMOS Technology substantially reduces device power requirements. The 2K/4K devices feature a 16-byte page write buffer. The 8K/16K/32K devices feature a 32-byte page write buffer. The device operates via the SPI bus serial interface and is enabled through a Chip Select ( $\overline{CS}$ ). In

addition to the Chip Select, the clock input (SCK), data in (SI) and data out (SO) are required to access the device. The reset function of the 25CXXX protects the system during brown out and power up/down conditions. During system failure the watchdog timer feature protects the microcontroller with a reset signal. The CAT25CXXX is designed with software and hardware write protection features including Block Lock protection. The device is available in 8-pin DIP, 8-pin SOIC, 16-pin SOIC and 14-pin TSSOP packages.

## PIN CONFIGURATION

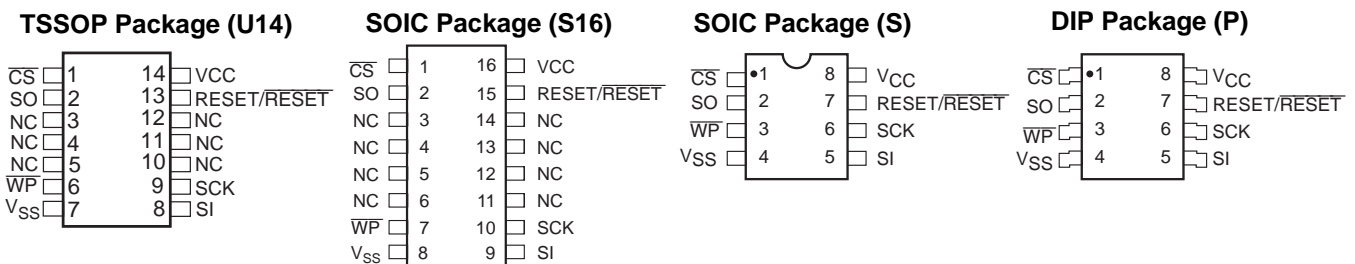

**PIN FUNCTIONS**

Pin Name	Function
SO	Serial Data Output
SCK	Serial Clock
WP	Write Protect
VCC	+1.8V to +6.0V Power Supply
VSS	Ground
CS	Chip Select
SI	Serial Data Input
RESET/RESET	Reset I/O
NC	No Connect

**BLOCK DIAGRAM**

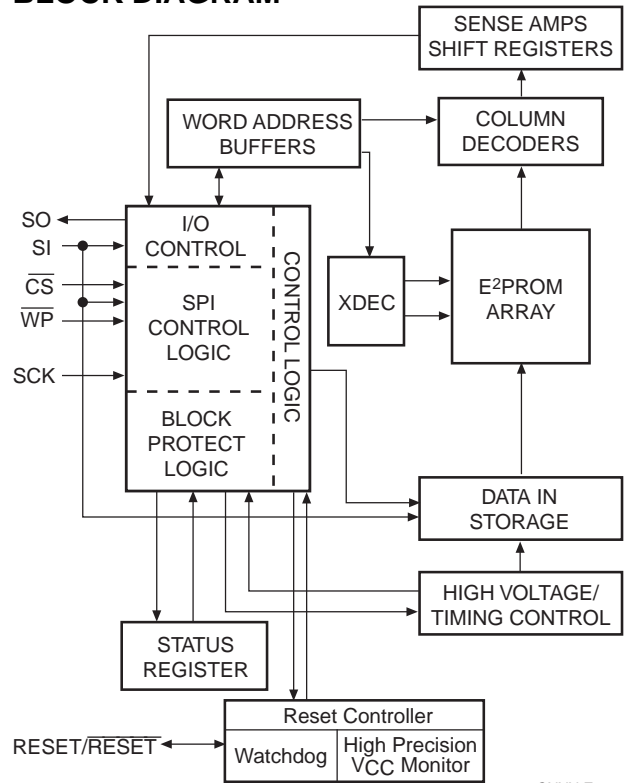

25CXXX F02.1

**RELIABILITY CHARACTERISTICS**

Symbol	Parameter	Min.	Max.	Units	Reference Test Method
N <sub>END</sub> <sup>(3)</sup>	Endurance	1,000,000		Cycles/Byte	MIL-STD-883, Test Method 1033
T <sub>DR</sub> <sup>(3)</sup>	Data Retention	100		Years	MIL-STD-883, Test Method 1008
V <sub>ZAP</sub> <sup>(3)</sup>	ESD Susceptibility	2000		Volts	MIL-STD-883, Test Method 3015
I <sub>LTH</sub> <sup>(3)(4)</sup>	Latch-Up	100		mA	JEDEC Standard 17

**Power-Up Timing<sup>(1)(2)</sup>**

Symbol	Parameter	Max.	Units
t <sub>PUR</sub>	Power-up to Read Operation	1	ms
t <sub>PUW</sub>	Power-up to Write Operation	1	ms

- (1) This parameter is tested initially and after a design or process change that affects the parameter.
- (2) t<sub>PUR</sub> and t<sub>PUW</sub> are the delays required from the time V<sub>CC</sub> is stable until the specified operation can be initiated.
- (3) This parameter is tested initially and after a design or process change that affects the parameter.
- (4) Latch-up protection is provided for stresses up to 100 mA on address and data pins from -1V to V<sub>CC</sub> +1V.

**ABSOLUTE MAXIMUM RATINGS\***

Temperature Under Bias .....	-55°C to +125°C
Storage Temperature .....	-65°C to +150°C
Voltage on any Pin with Respect to Ground <sup>(1)</sup> .....	-2.0V to +V <sub>CC</sub> +2.0V
V <sub>CC</sub> with Respect to Ground .....	-2.0V to +7.0V
Package Power Dissipation Capability (T <sub>a</sub> = 25°C) .....	1.0W
Lead Soldering Temperature (10 secs) .....	300°C
Output Short Circuit Current <sup>(2)</sup> .....	100 mA

**\*COMMENT**

Stresses above those listed under “Absolute Maximum Ratings” may cause permanent damage to the device. These are stress ratings only, and functional operation of the device at these or any other conditions outside of those listed in the operational sections of this specification is not implied. Exposure to any absolute maximum rating for extended periods may affect device performance and reliability.

**D.C. OPERATING CHARACTERISTICS**

V<sub>CC</sub> = +1.8V to +6.0V, unless otherwise specified.

Symbol	Parameter	Limits			Units	Test Conditions
		Min.	Typ.	Max.		
I <sub>CC1</sub>	Power Supply Current (Operating Write)			5	mA	V <sub>CC</sub> = 5V @ 5MHz SO=open; CS=V <sub>SS</sub>
I <sub>CC2</sub>	Power Supply Current (Operating Read)			0.4	mA	V <sub>CC</sub> = 5.5V F <sub>CLK</sub> = 5MHz
I <sub>SB</sub>	Power Supply Current (Standby)			0	μA	$\overline{CS} = V_{CC}$ V <sub>IN</sub> = V <sub>SS</sub> or V <sub>CC</sub>
I <sub>LI</sub>	Input Leakage Current			2	μA	
I <sub>LO</sub>	Output Leakage Current			3	μA	V <sub>OUT</sub> = 0V to V <sub>CC</sub> , CS = 0V
V <sub>IL</sub> <sup>(3)</sup>	Input Low Voltage	-1		V <sub>CC</sub> x 0.3	V	
V <sub>IH</sub> <sup>(3)</sup>	Input High Voltage	V <sub>CC</sub> x 0.7		V <sub>CC</sub> + 0.5	V	
V <sub>OL1</sub>	Output Low Voltage			0.4	V	4.5V ≤ V <sub>CC</sub> < 5.5V I <sub>OL</sub> = 3.0mA I <sub>OH</sub> = -1.6mA
V <sub>OH1</sub>	Output High Voltage	V <sub>CC</sub> - 0.8			V	
V <sub>OL2</sub>	Output Low Voltage			0.2	V	1.8V ≤ V <sub>CC</sub> < 2.7V I <sub>OL</sub> = 150μA I <sub>OH</sub> = -100μA
V <sub>OH2</sub>	Output High Voltage	V <sub>CC</sub> -0.2			V	

Note:

- (1) The minimum DC input voltage is -0.5V. During transitions, inputs may undershoot to -2.0V for periods of less than 20 ns. Maximum DC voltage on output pins is V<sub>CC</sub> +0.5V, which may overshoot to V<sub>CC</sub> +2.0V for periods of less than 20 ns.
- (2) Output shorted for no more than one second. No more than one output shorted at a time.
- (3) This parameter is tested initially and after a design or process change that affects the parameter.

Figure 1. Synchronous Data Timing

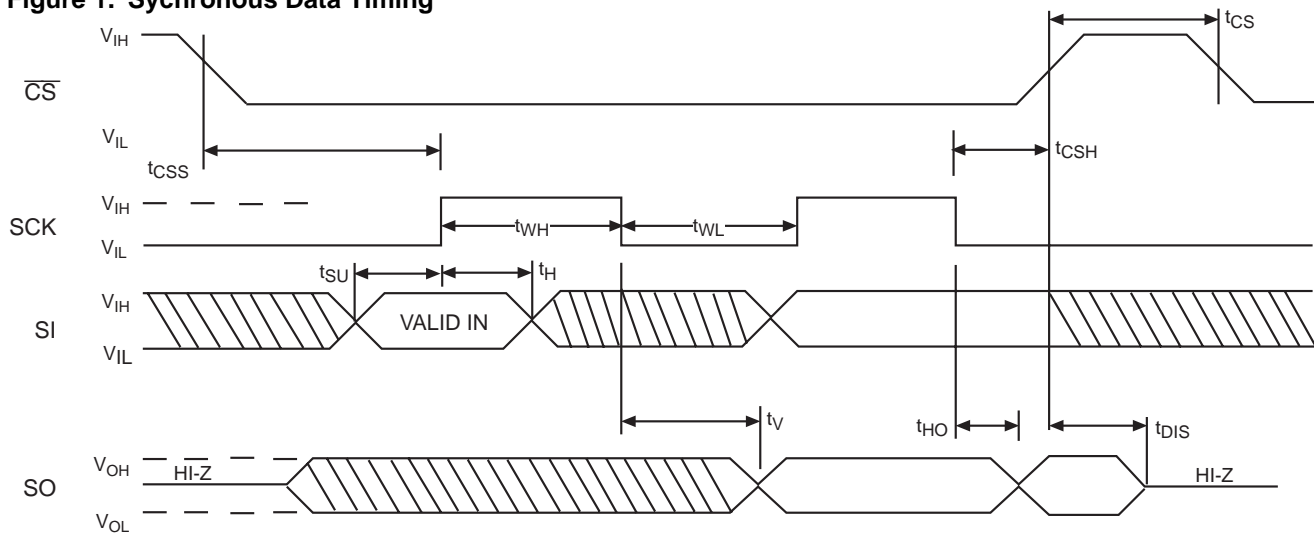

A.C. CHARACTERISTICS

SYMBOL	PARAMETER	Limits				UNITS	Test Conditions
		1.8, 2.5		4.5V-5.5V			
		Min.	Max.	Min.	Max.		
$t_{SU}$	Data Setup Time	50		10		ns	$C_L = 50pF$
$t_H$	Data Hold Time	50		20		ns	
$t_{WH}$	SCK High Time	200		40		ns	
$t_{WL}$	SCK Low Time	200		40		ns	
$f_{SCK}$	Clock Frequency	DC	2	DC	10	MHz	
$t_{LZ}$	$\overline{HOLD}$ to Output Low Z		50		50	ns	
$t_{RI}^{(1)}$	Input Rise Time		2		2	$\mu s$	
$t_{FI}^{(1)}$	Input Fall Time		2		2	$\mu s$	
$t_{HD}$	$\overline{HOLD}$ Setup Time	100		40		ns	
$t_{CD}$	$\overline{HOLD}$ HOLD Time	100		40		ns	
$t_{WC}$	Write Cycle Time		10		5	ms	
$t_V$	Output Valid from Clock Low		200		80	ns	
$t_{HO}$	Output HOLD Time	0		0		ns	
$t_{DIS}$	Output Disable Time		250		75	ns	
$t_{HZ}$	$\overline{HOLD}$ to Output High Z		100		50	ns	
$t_{CS}$	$\overline{CS}$ High Time	250		100		ns	
$t_{CSS}$	$\overline{CS}$ Setup Time	250		100		ns	
$t_{CSH}$	$\overline{CS}$ HOLD Time	250		100		ns	

NOTE:

(1) This parameter is tested initially and after a design or process change that affects the parameter.

**FUNCTIONAL DESCRIPTION**

The CAT25CXXX supports the SPI bus data transmission protocol. The synchronous Serial Peripheral Interface (SPI) helps the CAT25CXXX to interface directly with many of today’s popular microcontrollers. The CAT25CXXX contains an 8-bit instruction register. (The instruction set and the operation codes are detailed in the instruction set table)

After the device is selected with  $\overline{CS}$  going low, the first byte will be received. The part is accessed via the SI pin, with data being clocked in on the rising edge of SCK. The first byte contains one of the six op-codes that define the operation to be performed.

**PIN DESCRIPTION**

**SI:** Serial Input

SI is the serial data input pin. This pin is used to input all opcodes, byte addresses, and data to be written to the 25CXXX. Input data is latched on the rising edge of the serial clock.

**SO:** Serial Output

SO is the serial data output pin. This pin is used to transfer data out of the 25CXXX. During a read cycle, data is shifted out on the falling edge of the serial clock.

**SCK:** Serial Clock

SCK is the serial clock pin. This pin is used to synchronize the communication between the microcontroller and the 25CXXX. Opcodes, byte addresses, or data present on the SI pin are latched on the rising edge of the SCK. Data on the SO pin is updated on the falling edge of the SCK.

**RESET/RESET:** RESET I/O

These are open drain pins and can be used as reset trigger inputs. By forcing a reset condition on the pins the device will initiate and maintain a reset condition. RE-SET pin must be connected through a pull-down and  $\overline{RESET}$  pin must be connected through a pull-up device.

**$\overline{CS}$ :** Chip Select

$\overline{CS}$  is the Chip select pin.  $\overline{CS}$  low enables the CAT25CXXX and  $\overline{CS}$  high disables the CAT25CXXX.  $\overline{CS}$  high takes the SO output pin to high impedance and forces the devices into a Standby Mode (unless an internal write operation is underway) The CAT25CXXX draws ZERO current in the Standby mode. A high to low transition on  $\overline{CS}$  is required prior to any sequence being initiated. A low to high transition on  $\overline{CS}$  after a valid write sequence is what initiates an internal write cycle.

**$\overline{WP}$ :** Write Protect

$\overline{WP}$  is the Write Protect pin. The Write Protect pin will allow normal read/write operations when held high. When  $\overline{WP}$  is tied low and the WPEN bit in the status register is set to “1”, all write operations to the status register are inhibited.  $\overline{WP}$  going low while  $\overline{CS}$  is still low will interrupt a write to the status register. If the internal write cycle has already been initiated,  $\overline{WP}$  going low will have no effect on any write operation to the status register. The  $\overline{WP}$  pin function is blocked when the WPEN bit is set to 0.

**INSTRUCTION SET**

Instruction	Opcode	Operation
WREN	0000 0110	Enable Write Operations
WRDI	0000 0100	Disable Write Operations
RDSR	0000 0101	Read Status Register
WRSR	0000 0001	Write Status Register
READ	0000 X011 <sup>(1)</sup>	Read Data from Memory
WRITE	0000 X010 <sup>(1)</sup>	Write Data to Memory

Note:

(1) X=0 for 25C02X/08X/16X/32X. X=A8 for 25C04X

**STATUS REGISTER**

7	6	5	4	3	2	1	0
WPEN	X	WD1	WD0	BP1	BP0	WEL	$\overline{RDY}$

## Status Register

The Status Register indicates the status of the device. The RDY (Ready) bit indicates whether the CAT25CXXX is busy with a write operation. When set to 1 a write cycle is in progress and when set to 0 the device indicates it is ready. This bit is read only. The WEL (Write Enable) bit indicates the status of the write enable latch. When set to 1, the device is in a Write Enable state and when set to 0 the device is in a Write Disable state. The WEL bit can only be set by the WREN instruction and can be reset by the WRDI instruction.

The BPO and BP1 (Block Protect) bits indicate which blocks are currently protected. These bits are set by the user issuing the WRSR instruction. The user is allowed to protect quarter of the memory, half of the memory or the entire memory by setting these bits. Once protected the user may only read from the protected portion of the array. These bits are non-volatile.

The WPEN (Write Protect Enable) is an enable bit for the  $\overline{WP}$  pin. The  $\overline{WP}$  pin and WPEN bit in the status register control the programmable hardware write protect feature. Hardware write protection is enabled when  $\overline{WP}$  is low and WPEN bit is set to high. The user cannot write to the status register, (including the block protect bits and the WPEN bit) and the block protected sections in the memory array when the chip is hardware write protected. Only the sections of the memory array that are not block protected can be written. Hardware write protection is disabled when either  $\overline{WP}$  pin is high or the WPEN bit is zero.

The watchdog timer bits, WD0 and WD1, select the watchdog time-out period. These nonvolatile bits are programmed with the WRSR instruction.

## BLOCK PROTECTION BITS

Status Register Bits		Array Address Protected	Protection
BP1	BPO		
0	0	None	No Protection
0	1	25C02X: C0-FF 25C04X: 180-1FF 25C08X: 0300-03FF 25C16X: 0600-07FF 25C32X: 0C00-0FFF	Quarter Array Protection
1	0	25C02X: 80-FF 25C04X: 100-1FF 25C08X: 0200-03FF 25C16X: 0400-07FF 25C32X: 0800-0FFF	Half Array Protection
1	1	25C02X: 00-FF 25C04X: 000-1FF 25C08X: 0000-03FF 25C16X: 0000-07FF 25C32X: 0000-0FFF	Full Array Protection

## WATCHDOG TIMER BITS

WD1	WD0	Watchdog Timer Time-Out (Typical)
0	0	1.4 Seconds
0	1	600 Milliseconds
1	0	200 Milliseconds
1	1	Disabled

**DEVICE OPERATION FOR THE MEMORY FUNCTION**

**Write Enable and Disable**

The CAT25CXXX contains a write enable latch. This latch must be set before any write operation. The device powers up in a write disable state when V<sub>CC</sub> is applied. WREN instruction will enable writes (set the latch) to the device. WRDI instruction will disable writes (reset the latch) to the device. Disabling writes will protect the device against inadvertent writes.

**READ Sequence**

The part is selected by pulling  $\overline{CS}$  low. The 8-bit read instruction is transmitted to the CAT25CXXX, followed by the 16-bit address for 25C08X/16X/32X (only 10-bit addresses are used for 25C08X, 11-bit addresses are used for 25C16X, and 12-bit addresses are used for 25C32X. The rest of the bits are don't care bits) and 8-bit address for 25C02X/04X (for the 25C04X, bit 3 of the read data instruction contains address A8).

After the correct read instruction and address are sent, the data stored in the memory at the selected address is shifted out on the SO pin. The data stored in the memory at the next address can be read sequentially by continuing to provide clock pulses. The internal address pointer is automatically incremented to the next higher address

after each byte of data is shifted out. When the highest address is reached, the address counter rolls over to 0000H allowing the read cycle to be continued indefinitely. The read operation is terminated by pulling the  $\overline{CS}$  high. To read the status register, RDSR instruction should be sent. The contents of the status register are shifted out on the SO line. The status register may be read at any time even during a write cycle. Read sequence is illustrated in Figure 4. Reading status register is illustrated in Figure 5.

**WRITE Sequence**

The CAT25CXXX powers up in a Write Disable state. Prior to any write instructions, the WREN instruction must be sent to CAT25CXXX. The device goes into write enable state by pulling the  $\overline{CS}$  low and then clocking the WREN instruction into CAT25CXXX. The  $\overline{CS}$  must be brought high after the WREN instruction to enable writes to the device. If the write operation is initiated immediately after the WREN instruction without  $\overline{CS}$  being brought high, the data will not be written to the array because the write enable latch will not have been properly set. Also, for a successful write operation the address of the memory location(s) to be programmed must be outside the protected address field location selected by the block protection level.

**WRITE PROTECT ENABLE OPERATION**

WPEN	$\overline{WP}$	WEL	Protected Blocks	Unprotected Blocks	Status Register
0	X	0	Protected	Protected	Protected
0	X	1	Protected	Writable	Writable
1	Low	0	Protected	Protected	Protected
1	Low	1	Protected	Writable	Protected
X	High	0	Protected	Protected	Protected
X	High	1	Protected	Writable	Writable

**Figure 2. WREN Instruction Timing**

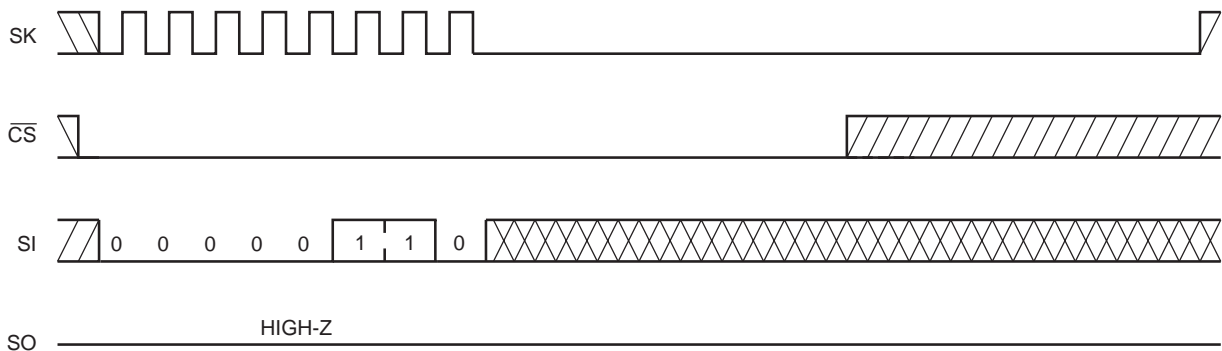

**Byte Write**

Once the device is in a Write Enable state, the user may proceed with a write sequence by setting the  $\overline{CS}$  low, issuing a write instruction via the SI line, followed by the 16-bit address for 25C08X/16X/32X (only 10-bit addresses are used for 25C08X, 11-bit addresses are used for 25C16X, and 12-bit addresses are used for 25C32X. The rest of the bits are don't care bits) and 8-bit address for 25C02X/04X (for the 25C04X, bit 3 of the read data instruction contains address A8). Programming will start after the  $\overline{CS}$  is brought high. The low to high transition of the  $\overline{CS}$  pin must occur during the SCK low time, immediately after clocking the least significant bit of the data. Figure 6 illustrates byte write sequence.

During an internal write cycle, all commands will be ignored except the RDSR (Read Status Register) instruction.

The Status Register can be read to determine if the write cycle is still in progress. If Bit 0 of the Status Register is set at 1, write cycle is in progress. If Bit 0 is set at 0, the device is ready for the next instruction.

**Page Write**

The CAT25CXXX features page write capability. After the initial byte, the host may continue to write up to 16 bytes of data to the CAT25C02X/04X and 32 bytes of data for 25C08X/16X/32X. After each byte of data received, lower order address bits are internally incremented by one; the high order bits of address will remain constant. The only restriction is that the X (X=16 for 25C02X/04X and X=32 for 25C08X/16X/32X) bytes must reside on the same page. If the address counter reaches the end of the page and clock continues, the counter will "roll over" to the first address of the page and overwrite any data that may have been written. The CAT25CXXX is automatically returned to the write disable state at the completion of the write cycle. Figure 8 illustrates the page write sequence.

To write to the status register, the WRSR instruction should be sent. Only Bit 2, Bit 3 and Bit 7 of the status register can be written using the WRSR instruction. Figure 7 illustrates the sequence of writing to status register.

**Figure 3. WRDI Instruction Timing**

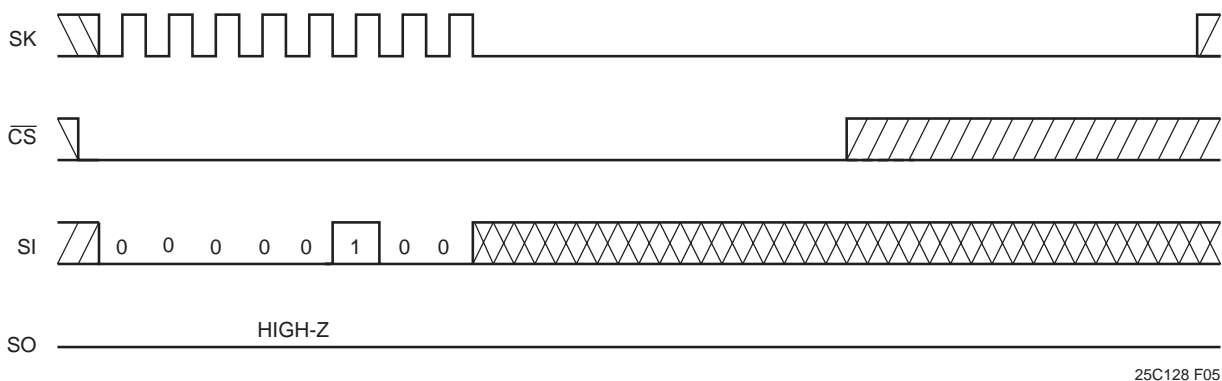

25C128 F05

**Figure 4. Read Instruction Timing**

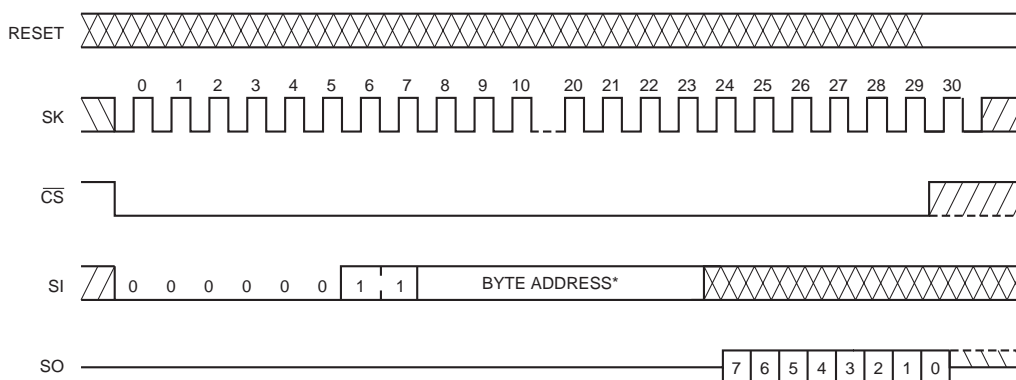

\*Please check the instruction set table for address



Figure 5. RDSR Timing

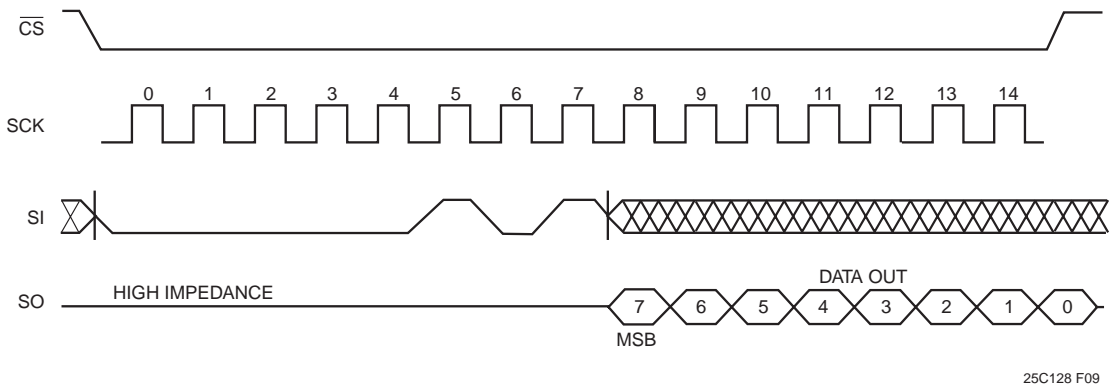

Figure 6. Write Instruction Timing

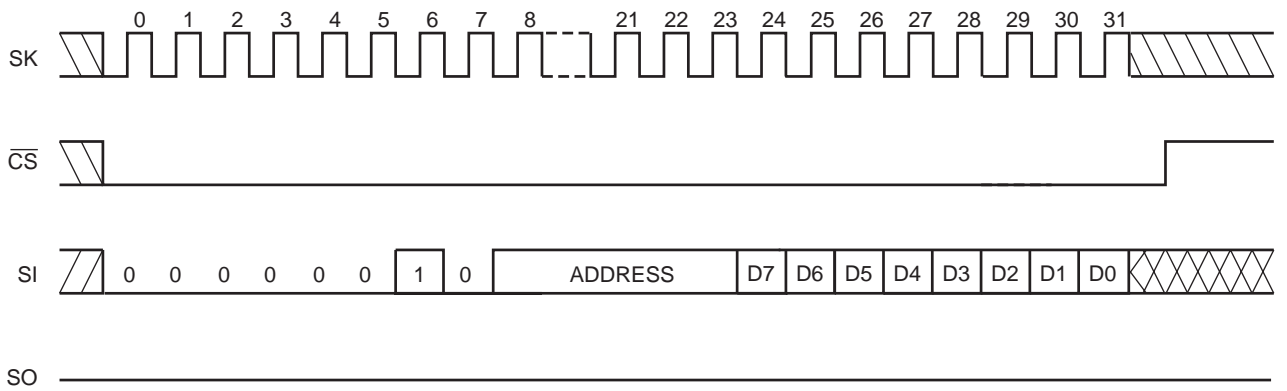
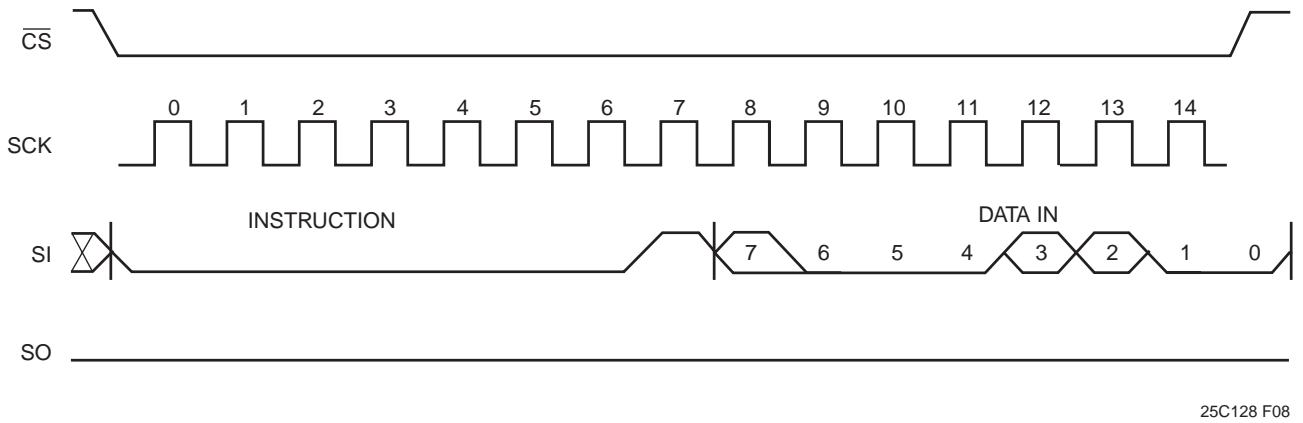

Figure 7. WRSR Timing



**DEVICE OPERATION FOR THE SUPERVISORY CIRCUIT**

**Reset Controller Description**

The CAT25CXXX provides a precision RESET controller that ensures correct system operation during brown-out and power-up/down conditions. It is configured with open drain RESET outputs. During power-up, the RESET outputs remain active until V<sub>CC</sub> reaches the V<sub>TH</sub> threshold and will continue driving the outputs for approximately 200ms (t<sub>PURST</sub>) after reaching V<sub>TH</sub>. After the t<sub>PURST</sub> timeout interval, the device will cease to drive reset outputs. At this point the reset outputs will be pulled up or down by their respective pull up/pull down devices. During power-down, the RESET outputs will begin driving active when V<sub>CC</sub> falls below V<sub>TH</sub>. The RESET outputs will be valid so long as V<sub>CC</sub> is >1.0V (V<sub>RVALID</sub>).

The RESET pins are I/Os; therefore, the CAT25CXXX can act as a signal conditioning circuit for an externally applied reset. The inputs are level triggered; that is, the RESET input in the 25CXXX will initiate a reset timeout after detecting a high and the  $\overline{\text{RESET}}$  input in the 25CXXX will initiate a reset timeout after detecting a low.

**Watchdog Timer**

The Watchdog Timer provides an independent protection for microcontrollers. During a system failure, the CAT25CXXX will respond with a reset signal after a

time out period (the time out period is defined by the watchdog timer bits WD0 and WD1) for lack of activity. 25CXXX is designed with the Watchdog Timer feature on the  $\overline{\text{CS}}$  input. For the 25CXXX, if the microcontroller does not toggle the  $\overline{\text{CS}}$  pin within the time out period the Watchdog Timer times out. This will generate a reset condition on reset outputs. The Watchdog Timer is cleared by any transition on  $\overline{\text{CS}}$ .

As long as the reset signal is asserted, the Watchdog Timer will not count and will stay cleared.

**Reset Threshold Voltage**

From the factory the 25CXXX is offered in six different variations of reset threshold voltages. They are 4.50-4.75V, 4.25-4.50V, 3.00-3.15V, 2.85-3.00V, 2.55-2.70V and 1.7-1.8V. To provide added flexibility to design engineers using this product, the 25CXXX is designed with an additional feature of programming the reset threshold voltage. This allows the user to change the existing reset threshold voltage to one of the other five reset threshold voltages. Once the reset threshold voltage is selected it will not change even after cycling the power, unless the user uses the programmer to change the reset threshold voltage. However, the programming function is available only through third party programmer manufacturers. Please call Catalyst for a list of programmer manufacturers who support this function.

**Figure 8. Page Write Instruction Timing**

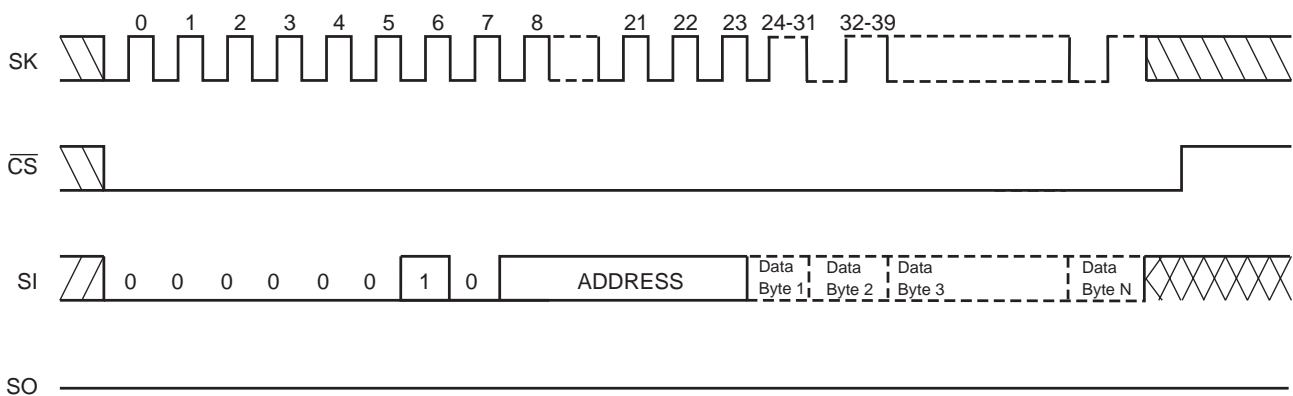

**RESET CIRCUIT CHARACTERISTICS**

Symbol	Parameter	Min.	Max.	Units
$t_{GLITCH}$	Glitch Reject Pulse Width		100	ns
$V_{RT}$	Reset Threshold Hysteresis	15		mV
$V_{OLRS}$	Reset Output Low Voltage ( $I_{OLRS}=1mA$ )		0.4	V
$V_{OHRS}$	Reset Output High Voltage	$V_{CC}-0.75$		V
$V_{TH}$	Reset Threshold ( $V_{CC}=5V$ ) (25CXXX-45)	4.50	4.75	V
	Reset Threshold ( $V_{CC}=5V$ ) (25CXXX-42)	4.25	4.50	
	Reset Threshold ( $V_{CC}=3.3V$ ) (25CXXX-30)	3.00	3.15	
	Reset Threshold ( $V_{CC}=3.3V$ ) (25CXXX-28)	2.85	3.00	
	Reset Threshold ( $V_{CC}=3V$ ) (25CXXX-25)	2.55	2.70	
	Reset Threshold ( $V_{CC}=1.8V$ ) (25CXXX-17)	1.70	1.80	
$t_{PURST}$	Power-Up Reset Timeout	130	270	ms
$t_{RPD}$	$V_{TH}$ to RESET Output Delay		5	$\mu s$
$V_{RVALID}$	RESET Output Valid	1		V

**Figure 9. RESET Output Timing**

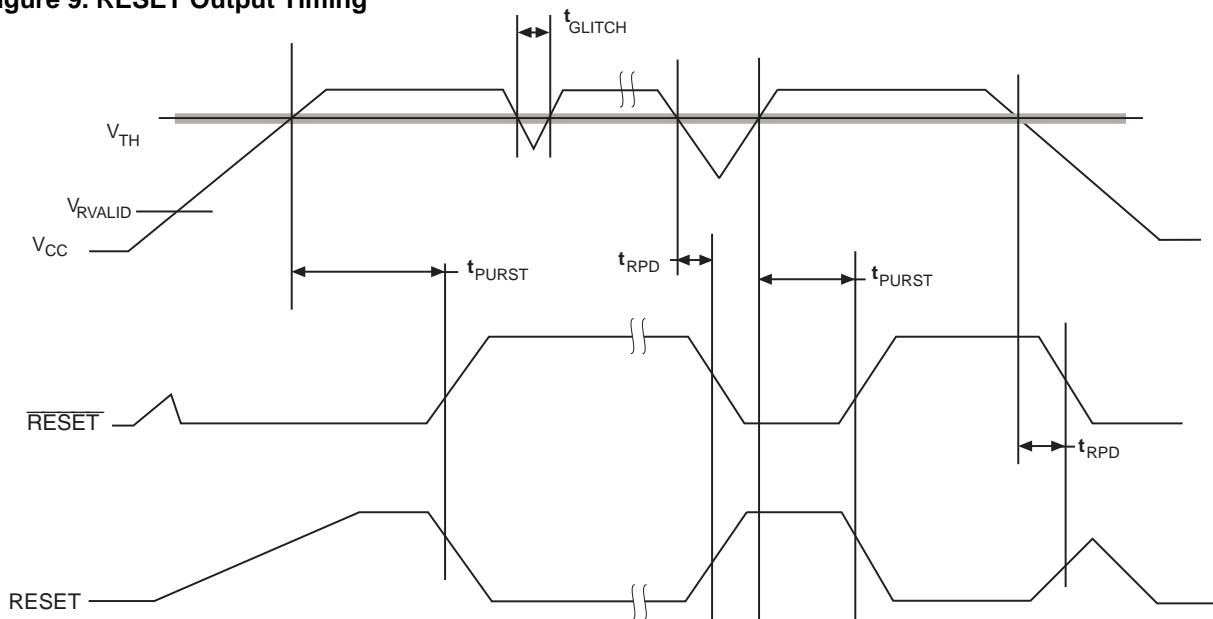

**DESIGN CONSIDERATIONS**

The CAT25CXXX powers up in a write disable state and in a low power standby mode. A WREN instruction must be issued to perform any writes to the device after power up. Also, on power up  $\overline{CS}$  should be brought low to enter a ready state and receive an instruction. After a successful byte/page write or status register write the CAT25CXXX goes into a write disable mode.  $\overline{CS}$  must be set high after the proper number of clock cycles to start an internal write cycle. Access to the array during an internal write cycle is ignored and programming is continued. On power up, SO is in a high impedance. If

an invalid op code is received, no data will be shifted into the CAT25CXXX, and the serial output pin (SO) will remain in a high impedance state until the falling edge of  $\overline{CS}$  is detected again.

The  $V_{CC}$  sense provides write protection when  $V_{CC}$  falls below the reset threshold value ( $V_{TH}$ ). The  $V_{CC}$  lock out inhibits writes to the serial EEPROM whenever  $V_{CC}$  falls below (power down)  $V_{TH}$  or until  $V_{CC}$  reaches the reset threshold (power up)  $V_{TH}$ .

**ORDERING INFORMATION**

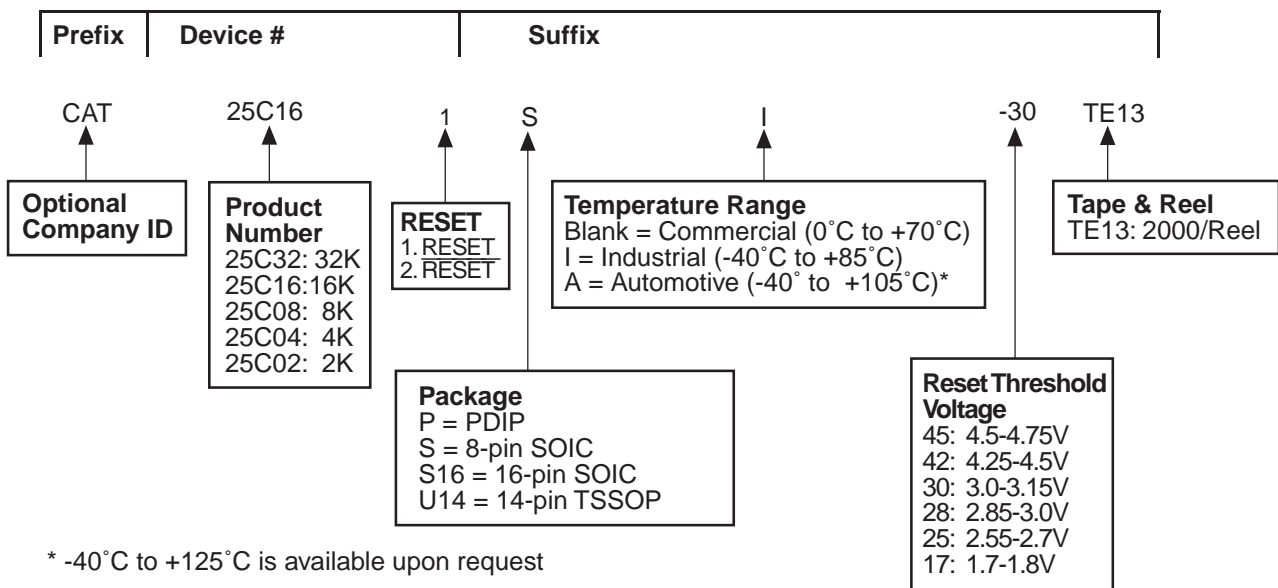

Notes:

(1) The device used in the above example is a 25C161SI-30TE13 (RESET, SOIC, Industrial Temperature, 3.0-3.15 Reset Threshold Voltage, Tape & Reel)