

CAT504

8-Bit Quad DACpot

FEATURES

- Output settings retained without power
- Output range includes both supply rails
- 4 independently addressable outputs
- 1 LSB Accuracy
- Serial μ P interface
- Single supply operation: 2.7V-5.5V
- Setting read-back without effecting outputs

APPLICATIONS

- Automated product calibration.
- Remote control adjustment of equipment
- Offset, gain and zero adjustments in Self-Calibrating and Adaptive Control systems.
- Tamper-proof calibrations.

DESCRIPTION

The CAT504 is a quad 8-Bit Memory DAC designed as an electronic replacement for mechanical potentiometers and trim pots. Intended for final calibration of products such as camcorders, fax machines and cellular telephones on automated high volume production lines, it is also well suited for systems capable of self calibration, and applications where equipment which is either difficult to access or in a hazardous environment, requires periodic adjustment.

The 4 independently programmable DAC's have an output range which includes both supply rails. Output settings, stored in non-volatile EEPROM memory, are not lost when the device is powered down and are automatically reinstated when power is returned. Each output can be dithered to test new output values without effecting the stored settings and stored settings can be read back without disturbing the DAC's output.

Control of the CAT504 is accomplished with a simple 3 wire serial interface. A Chip Select pin allows several CAT504s to share a common serial interface and communication back to the host controller is via a single serial data line thanks to the CAT504's Tri-Stated Data Output pin.

The CAT504 operates from a single 3–5 volt power supply drawing just a few milliwatts of power. When storing data in EEPROM memory an additional 20 volt low current supply is required.

The CAT504 is available in the 0 to 70° C Commercial and –40° C to + 85° C Industrial operating temperature ranges and offered in 14-pin plastic DIP and Surface mount packages.

FUNCTIONAL DIAGRAM

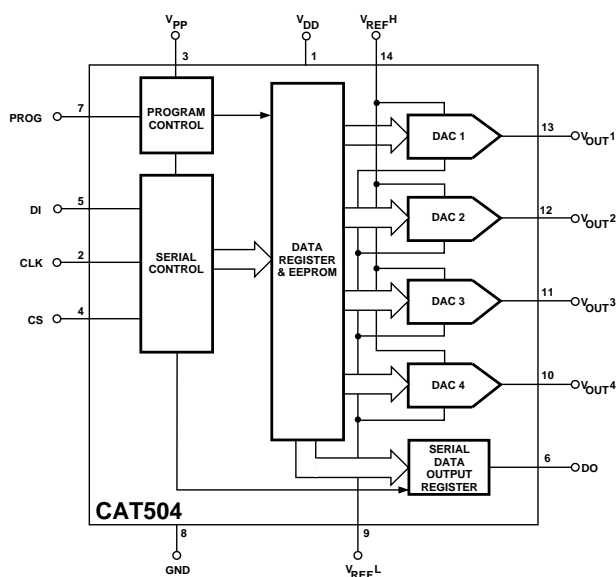

PIN CONFIGURATION

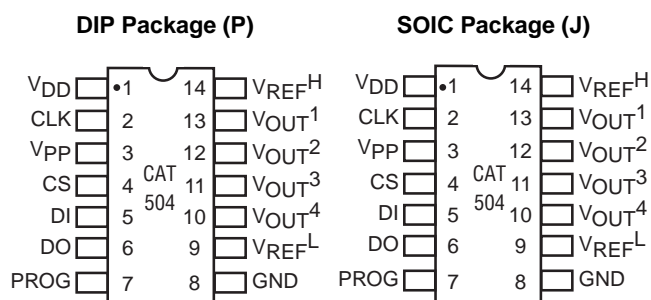

CAT504

ABSOLUTE MAXIMUM RATINGS*

Supply Voltage

V_{DD} to GND -0.5V to +7V

V_{PP} to GND -0.5V to +22V

Inputs

CLK to GND -0.5V to $V_{DD} + 0.5V$

CS to GND -0.5V to $V_{DD} + 0.5V$

DI to GND -0.5V to $V_{DD} + 0.5V$

PROG to GND -0.5V to $V_{DD} + 0.5V$

V_{REFH} to GND -0.5V to $V_{DD} + 0.5V$

V_{REFL} to GND -0.5V to $V_{DD} + 0.5V$

Outputs

D_0 to GND -0.5V to $V_{DD} + 0.5V$

V_{OUT} 1– 4 to GND -0.5V to $V_{DD} + 0.5V$

Operating Ambient Temperature

Commercial ('C' suffix) 0°C to +70°C

Industrial ('I' suffix) -40°C to +85°C

Junction Temperature +150°C

Storage Temperature -65°C to +150°C

Lead Soldering (10 sec max) +300°C

* Stresses above those listed under Absolute Maximum Ratings may cause permanent damage to the device. Absolute Maximum Ratings are limited values applied individually while other parameters are within specified operating conditions, and functional operation at any of these conditions is NOT implied. Device performance and reliability may be impaired by exposure to absolute rating conditions for extended periods of time.

RELIABILITY CHARACTERISTICS

Symbol	Parameter	Min	Max	Units	Test Method
$V_{ZAP}^{(1)}$	ESD Susceptibility	2000		Volts	MIL-STD-883, Test Method 3015
$I_{LTH}^{(1)(2)}$	Latch-Up	100		mA	JEDEC Standard 17

NOTES: 1. This parameter is tested initially and after a design or process change that affects the parameter.

2. Latch-up protection is provided for stresses up to 100mA on address and data pins from -1V to $V_{CC} + 1V$.

DC ELECTRICAL CHARACTERISTICS:

$V_{DD} = 2.7V$ to $5.5V$, $V_{REFH} = V_{DD}$, $V_{REFL} = 0V$, unless otherwise specified

Symbol	Parameter	Conditions	Min	Typ	Max	Units
	Resolution		8	—	—	Bits

Accuracy

INL	Integral Linearity Error	$I_{LOAD} = 250$ nA, $T_R = C$	—	—	± 1	LSB
		$T_R = I$	—	—	± 1	LSB
		$I_{LOAD} = 1$ μ A, $T_R = C$	—	—	± 2	LSB
		$T_R = I$	—	—	± 2	LSB
DNL	Differential Linearity Error	$I_{LOAD} = 250$ nA, $T_R = C$	—	—	± 0.5	LSB
		$T_R = I$	—	—	± 0.5	LSB
		$I_{LOAD} = 1$ μ A, $T_R = C$	—	—	± 1.5	LSB
		$T_R = I$	—	—	± 1.5	LSB

Logic Inputs

I_{IH}	Input Leakage Current	$V_{IN} = V_{DD}$	—	—	10	μ A
I_{IL}	Input Leakage Current	$V_{IN} = 0V$	—	—	-10	μ A
V_{IH}	High Level Input Voltage		2	—	V_{DD}	V
V_{IL}	Low Level Input Voltage		0	—	0.8	V

References

V_{RH}	V_{REFH} Input Voltage Range		2.7	—	V_{DD}	V
V_{RL}	V_{REFL} Input Voltage Range		GND	—	$V_{DD} - 2.7$	V
Z_{IN}	$V_{REFH} - V_{REFL}$ Resistance		—	7k	—	Ω

Logic Outputs

V_{OH}	High Level Output Voltage	$I_{OH} = -40$ μ A	$V_{DD} - 0.3$	—	—	V
V_{OL}	Low Level Output Voltage	$I_{OL} = 1$ mA, $V_{DD} = +5V$	—	—	0.4	V
		$I_{OL} = 0.4$ mA, $V_{DD} = +3V$	—	—	0.4	V

DC ELECTRICAL CHARACTERISTICS (Cont.):
 $V_{DD} = 2.7V$ to $5.5V$, $V_{REFH} = +V_{DD}$, $V_{REFL} = 0V$, unless otherwise specified

Symbol	Parameter	Conditions	Min	Typ	Max	Units
Analog Output						
FSO	Full-Scale Output Voltage	$V_R = V_{REFH} - V_{REFL}$	$0.99 V_R$	$0.995 V_R$	—	V
ZSO	Zero-Scale Output Voltage	$V_R = V_{REFH} - V_{REFL}$	—	$0.005 V_R$	$0.10 V_R$	V
I_L	DAC Output Load Current		—	—	1	μA
R _{OUT}	DAC Output Impedance	$V_{DD} = +5V$	—	—	20k	Ω
		$V_{DD} = +3V$	—	—	40k	Ω
PSSR	Power Supply Rejection	$I_{LOAD} = 250 nA$	—	—	1	LSB / V

Temperature

TC _O	V _{OUT} Temperature Coefficient	$V_{REFH} = +5V$, $V_{REFL} = 0V$ $V_{DD} = +5V$, $I_{LOAD} = 250nA$	—	—	200	$\mu V / ^\circ C$
TC _{REF}	Temperature Coefficient of V _{REF} Resistance	V_{REFH} to V_{REFL}	—	700	—	ppm / $^\circ C$

Power Supply

I _{DD}	Supply Current	Excludes V _{REF}	—	—	50	μA
I _{PP}	Programming Current	$V_{PP} = +19V$	—	200	500	μA
V _{DD}	Operating Voltage Range		2.7	—	5.5	V
V _{PP}	Programing Voltage Range		18	19	20	V

AC ELECTRICAL CHARACTERISTICS:
 $V_{DD} = 2.7V$ to $5.5V$, $V_{REFH} = +V_{DD}$, $V_{REFL} = 0V$, unless otherwise specified

Symbol	Parameter	Conditions	Min	Typ	Max	Units
Digital						
t _{CSMIN}	Minimum CS Low Time		150	—	—	ns
t _{CSS}	CS Setup Time		100	—	—	ns
t _{CSH}	CS Hold Time	C _L = 100 pF see note 1	0	—	—	ns
t _{DIS}	DI Setup Time		50	—	—	ns
t _{DIH}	DI Hold Time		50	—	—	ns
t _{DO1}	Output Delay to 1		—	—	150	ns
t _{DO0}	Output Delay to 0		—	—	150	ns
t _{HZ}	Output Delay to High-Z		—	400	—	ns
t _{LZ}	Output Delay to Low-Z	—	400	—	ns	
t _{PROG}	Erase/Write Pulse Width		3	5	—	ms
t _{PS}	PROG Setup Time		150	—	—	ns
t _{CLKH}	Minimum CLK High Time		500	—	—	ns
t _{CLKL}	Minimum CLK Low Time		300	—	—	ns
f _C	Clock Frequency		DC	—	1	MHz

Analog

t _{DS}	DAC Settling Time to 1/2 LSB	C _{LOAD} = 10 pF, V _{DD} = +5V	—	3	10	μs
		C _{LOAD} = 10 pF, V _{DD} = +3V	—	6	10	μs

Pin Capacitance

C _{IN}	Input Capacitance	V _{IN} = 0V, f = 1 MHz ⁽²⁾	—	8	—	pF
C _{OUT}	Output Capacitance	V _{OUT} = 0V, f = 1 MHz ⁽²⁾	—	6	—	pF

- NOTES:** 1. All timing measurements are defined at the point of signal crossing $V_{DD} / 2$.
2. These parameters are periodically sampled and are not 100% tested.

A. C. TIMING DIAGRAM

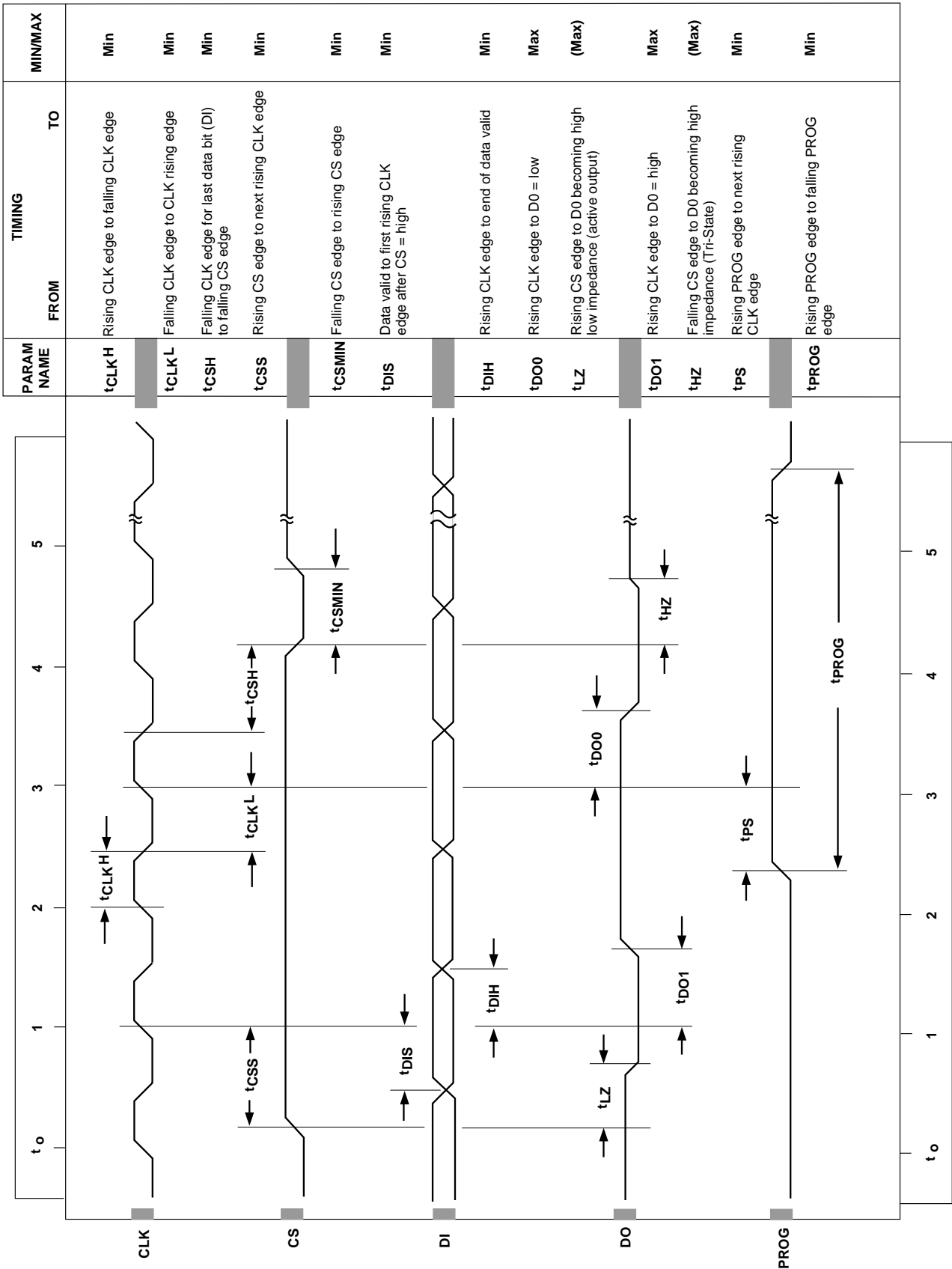

PIN DESCRIPTION

Pin	Name	Function
1	V _{DD}	Power supply positive.
2	CLK	Clock input pin
3	V _{PP}	EEPROM Programming Voltage
4	CS	Chip Select
5	DI	Serial data input pin.
6	DO	Serial data output pin.
7	PROG	EEPROM Programming Enable Input
8	GND	Power supply ground.
9	V _{REFL}	Minimum DAC output voltage.
10	V _{OUT4}	DAC output channel 4.
11	V _{OUT3}	DAC output channel 3.
12	V _{OUT2}	DAC output channel 2.
13	V _{OUT1}	DAC output channel 1.
14	V _{REFH}	Maximum DAC output voltage.

DAC addressing is as follows:

DAC OUTPUT	A0	A1
V _{OUT1}	0	0
V _{OUT2}	1	0
V _{OUT3}	0	1
V _{OUT4}	1	1

DEVICE OPERATION

The CAT504 is a quad 8-bit Digital to Analog Converter (DAC) whose outputs can be programmed to any one of 256 individual voltage steps. Once programmed, these output settings are retained in non-volatile EEPROM memory and will not be lost when power is removed from the chip. Upon power up the DACs return to the settings stored in EEPROM memory. Each DAC can be written to and read from independently without effecting the output voltage during the read or write cycle. Each output can also be temporarily adjusted without changing the stored output setting, which is useful for testing new output settings before storing them in memory.

DIGITAL INTERFACE

The CAT504 employs a standard 3 wire serial control interface consisting of Clock (CLK), Chip Select (CS) and Data In (DI) inputs. For all operations, address and data are shifted in LSB first. In addition, all digital data must be preceded by a logic "1" as a start bit. The DAC address and data are clocked into the DI pin on the clock's rising edge. When sending multiple blocks of information a minimum of two clock cycles is required between the last block sent and the next start bit.

Multiple devices may share a common input data line by selectively activating the CS control of the desired IC. Data Outputs (DO) can also share a common line because the DO pin is Tri-Stated and returns to a high impedance when not in use.

CHIP SELECT

Chip Select (CS) enables and disables the CAT504's read and write operations. When CS is high data may be

read to or from the chip, and the Data Output (DO) pin is active. Data loaded into the DAC control registers will remain in effect until CS goes low. Bringing CS to a logic low returns all DAC outputs to the settings stored in EEPROM memory and switches DO to its high impedance Tri-State mode.

Because CS functions like a reset the CS pin has been equipped with a 30 ns to 90 ns filter circuit to prevent noise spikes from causing unwanted resets and the loss of volatile data.

CLOCK

The CAT504's clock controls both data flow in and out of the IC and EEPROM memory cell programming. Serial data is shifted into the DI pin and out of the DO pin on the clock's rising edge. While it is not necessary for the clock to be running between data transfers, the clock must be operating in order to write to EEPROM memory, even though the data being saved may already be resident in the DAC control register.

No clock is necessary upon system power-up. The CAT504's internal power-on reset circuitry loads data from EEPROM to the DACs without using the external clock.

As data transfers are edge triggered clean clock transitions are necessary to avoid falsely clocking data into the control registers. Standard CMOS and TTL logic families work well in this regard and it is recommended that any mechanical switches used for breadboarding or device evaluation purposes be debounced by a flip-flop or other suitable debouncing circuit.

V_{REF}

V_{REF}, the voltage applied between pins V_{REFH} and V_{REFL}, sets the DAC's Zero to Full Scale output range where V_{REFL} = Zero and V_{REFH} = Full Scale. V_{REF} can span the full power supply range or just a fraction of it. In typical applications V_{REFH} and V_{REFL} are connected across the power supply rails. When using less than the full supply voltage V_{REFH} is restricted to voltages between V_{DD} and V_{DD}/2 and V_{REFL} to voltages between GND and V_{DD}/2.

V_{PP}

When saving data to non-volatile EEPROM memory an external voltage of 18–20 volts must be applied to the V_{PP} pin. This voltage need only be present during the programming cycle and may be removed or turned off the remainder of the time. While it is not necessary to remove or power down V_{PP} between programming cycles, some power sensitive applications may choose to do so. In such cases, the V_{PP} supply must be given sufficient time to come up and stabilize before issuing the PROG command.

DATA OUTPUT

Data is output serially by the CAT504, LSB first, via the Data Out (DO) pin following the reception of a start bit and two address bits by the Data Input (DI). DO becomes active whenever CS goes high and resumes its high impedance Tri-State mode when CS returns low. Tri-Stating the DO pin allows several 504s to share a single serial data line and simplifies interfacing multiple 504s to a microprocessor.

WRITING TO MEMORY

Programming the CAT504's EEPROM memory is accomplished through the application of an externally generated programming voltage, V_{PP}, and the control signals: Chip Select (CS) and Program (PROG). With

CS high, a start bit followed by a two bit DAC address and eight data bits are clocked into the DAC control register via the DI pin. Data enters on the clock's rising edge. The DAC output changes to its new setting on the clock cycle following D7, the last data bit.

Programming is achieved by bringing PROG high for a minimum of 3 ms while supplying 18 to 20 volts to the V_{PP} pin. PROG must be brought high sometime after the start bit and at least 150 ns prior to the rising edge of the clock cycle immediately following the D7 bit. Two clock cycles after the D7 bit the DAC control register will be ready to receive the next set of address and data bits. The clock must be kept running throughout the programming cycle. Internal control circuitry takes care of ramping the programming voltage for data transfer to the EEPROM cells. The CAT504's EEPROM memory cells will endure over 100,000 write cycles and will retain data for a minimum of 20 years without being refreshed.

READING DATA

Each time data is transferred into a DAC control register currently held data is shifted out via the DI pin, thus in every data transaction a read cycle occurs. Note, however, that the reading process is destructive. Data must be removed from the register in order to be read. Figure 2 depicts a Read Only cycle in which no change occurs in the DAC's output. This feature allows μ Ps to poll DACs for their current setting without disturbing the output voltage but it assumes that the setting being read is also stored in EEPROM so that it can be restored at the end of the read cycle. In Figure 2 CS returns low before the 13th clock cycle completes. In doing so the EEPROM's setting is reloaded into the DAC control register. Since this value is the same as that which had been there previously no change in the DAC's output is noticed. Had the value held in the control register been different from that stored in EEPROM then *a change would occur* at the read cycle's conclusion.

Figure 1. Writing to Memory

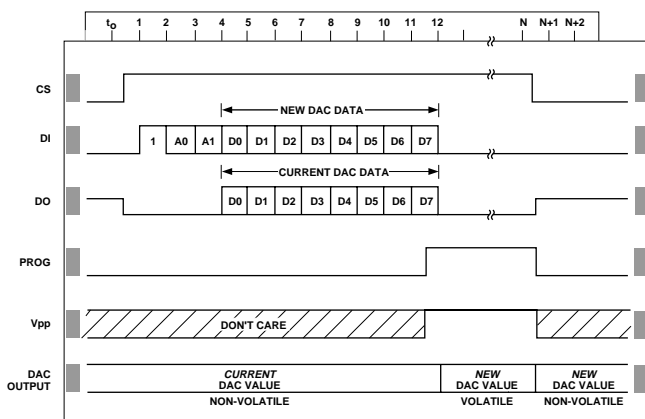
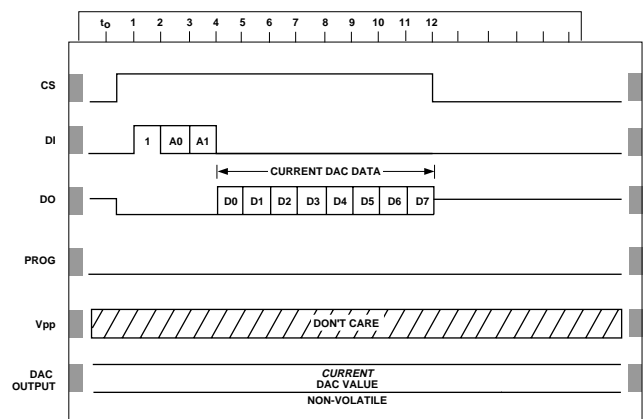

Figure 2. Reading from Memory



TEMPORARILY CHANGE OUTPUT

The CAT504 allows temporary changes in DAC's output to be made without disturbing the settings retained in EEPROM memory. This feature is particularly useful when testing for a new output setting and allows for user adjustment of preset or default values without losing the original factory settings.

Figure 3 shows the control and data signals needed to effect a temporary output change. DAC settings may be changed as many times as required and can be made to any of the four DACs in any order or sequence. The temporary setting(s) remain in effect long as CS remains high. When CS returns low all four DACs will return to the output values stored in EEPROM memory.

When it is desired to save a new setting acquired using this feature, the new value must be reloaded into the DAC control register prior to programming. This is because the CAT504's internal control circuitry discards the new data from the programming register two clock cycles after receiving it (after reception is complete) if no PROG signal is received.

Figure 3. Temporary Change in Output

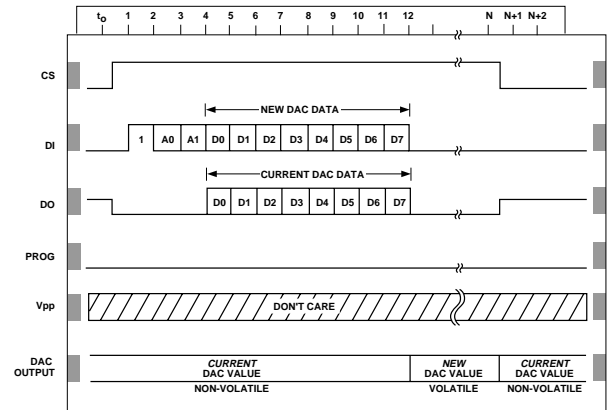

APPLICATION CIRCUITS

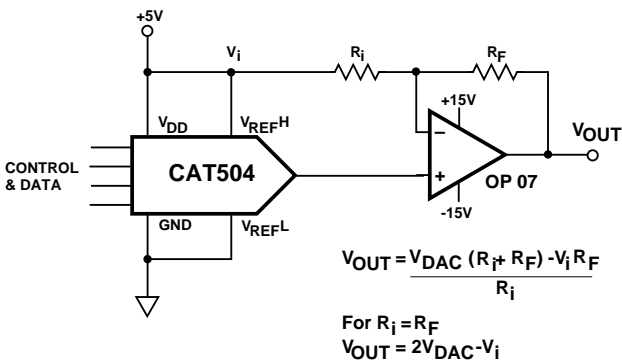
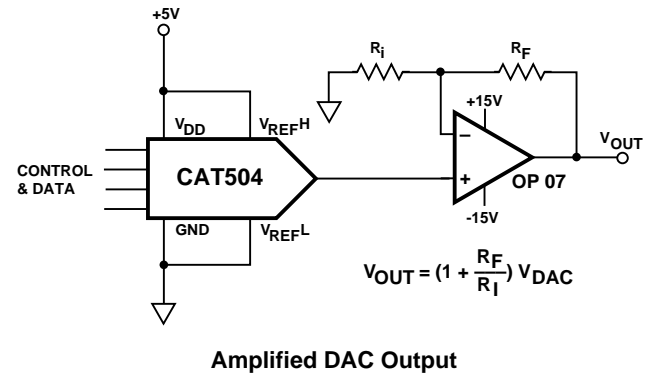
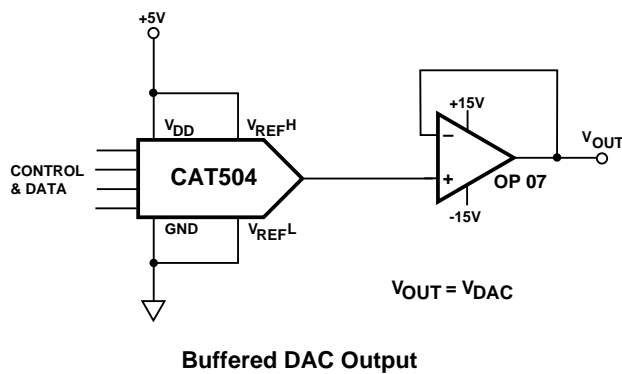

DAC INPUT		DAC OUTPUT		ANALOG OUTPUT
MSB	LSB	$V_{DAC} = \frac{CODE}{255} (V_{FS} - V_{ZERO}) + V_{ZERO}$		
			$V_{FS} = 0.99 V_{REF}$	$V_{REF} = 5V$ $R_I = R_F$
			$V_{ZERO} = 0.01 V_{REF}$	
1111	1111	$\frac{255}{255}$	$(.98 V_{REF}) + .01 V_{REF} = .990 V_{REF}$	$V_{OUT} = +4.90V$
1000	0000	$\frac{128}{255}$	$(.98 V_{REF}) + .01 V_{REF} = .502 V_{REF}$	$V_{OUT} = +0.02V$
0111	1111	$\frac{127}{255}$	$(.98 V_{REF}) + .01 V_{REF} = .498 V_{REF}$	$V_{OUT} = -0.02V$
0000	0001	$\frac{1}{255}$	$(.98 V_{REF}) + .01 V_{REF} = .014 V_{REF}$	$V_{OUT} = -4.86V$
0000	0000	$\frac{0}{255}$	$(.98 V_{REF}) + .01 V_{REF} = .010 V_{REF}$	$V_{OUT} = -4.90V$

Bipolar DAC Output

APPLICATION CIRCUITS (Cont.)

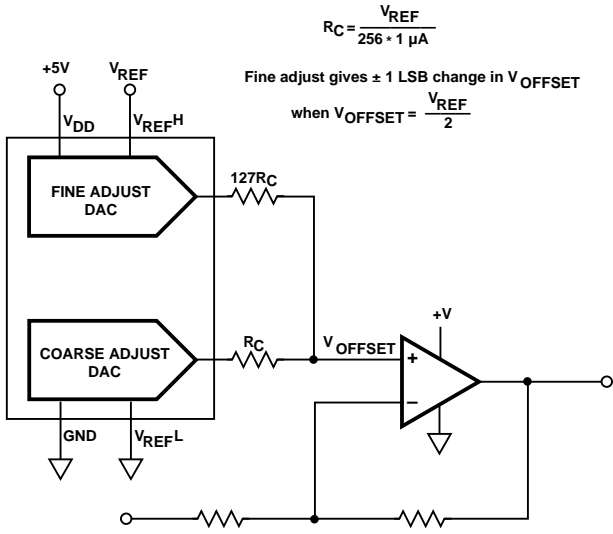

Coarse-Fine Offset Control by Averaging DAC Outputs for Single Power Supply Systems

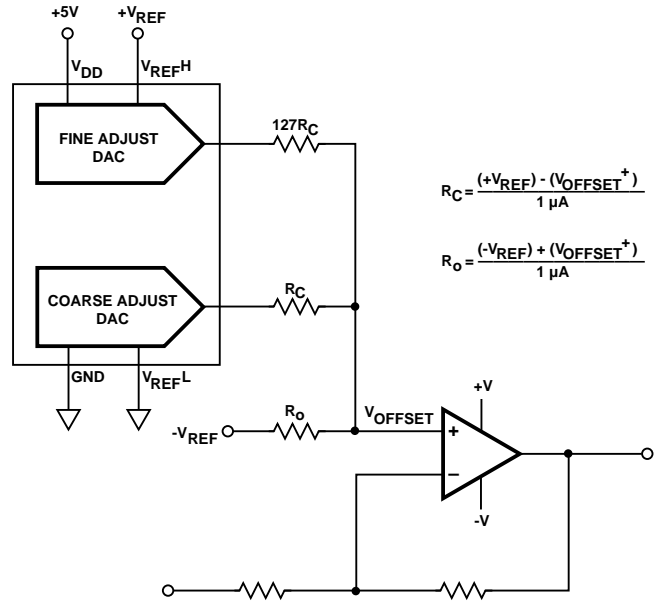

Coarse-Fine Offset Control by Averaging DAC Outputs for Dual Power Supply Systems

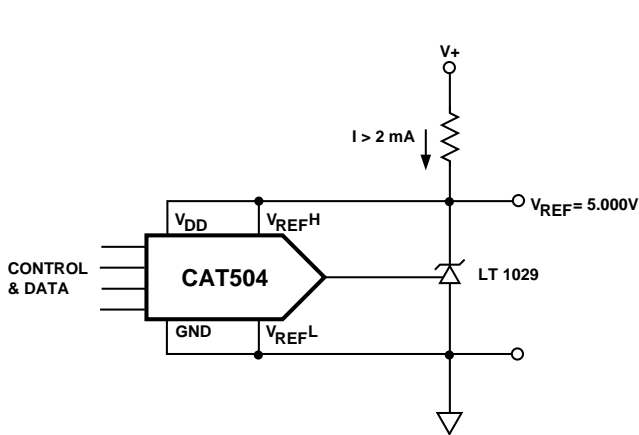

Digitally Trimmed Voltage Reference

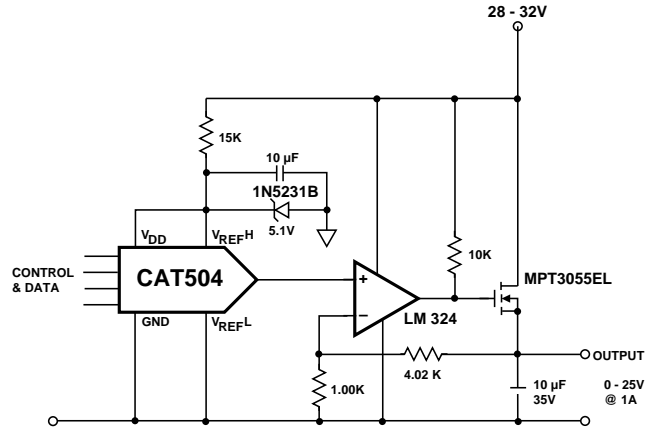

Digitally Controlled Voltage Reference

APPLICATION CIRCUITS (Cont.)

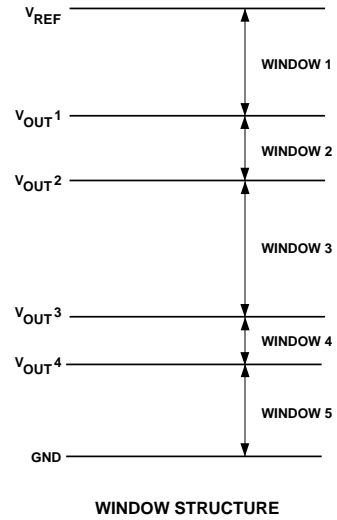
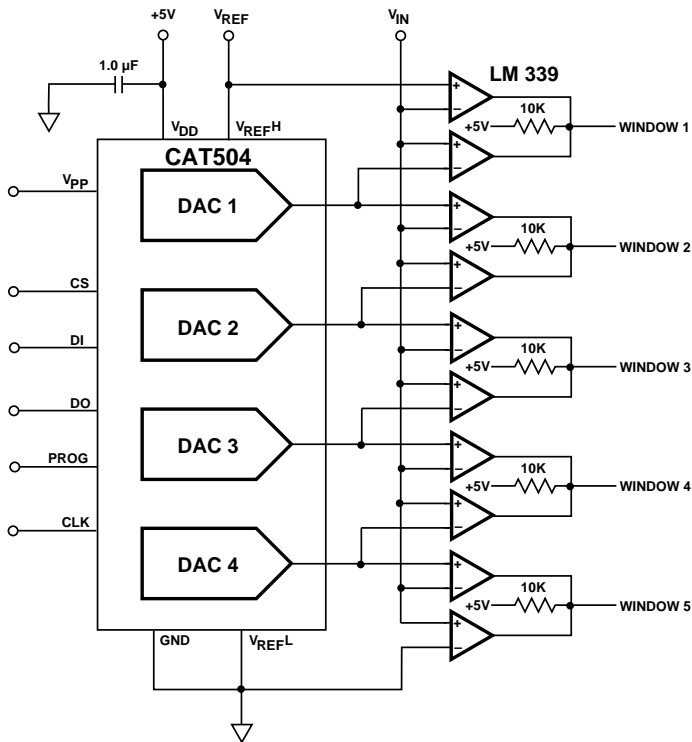

Staircase Window Comparator

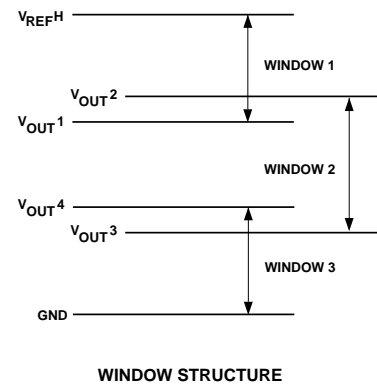
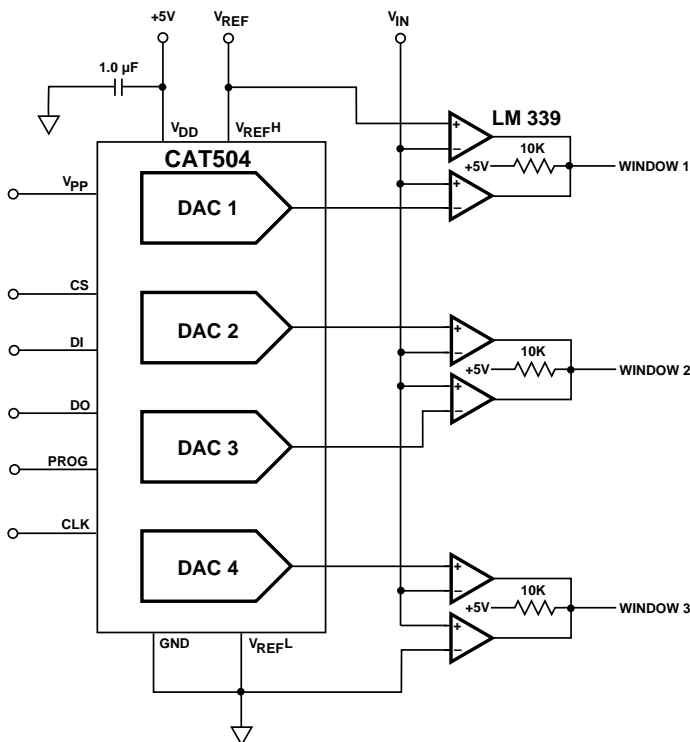

Overlapping Window Comparator

APPLICATION CIRCUITS (Cont.)

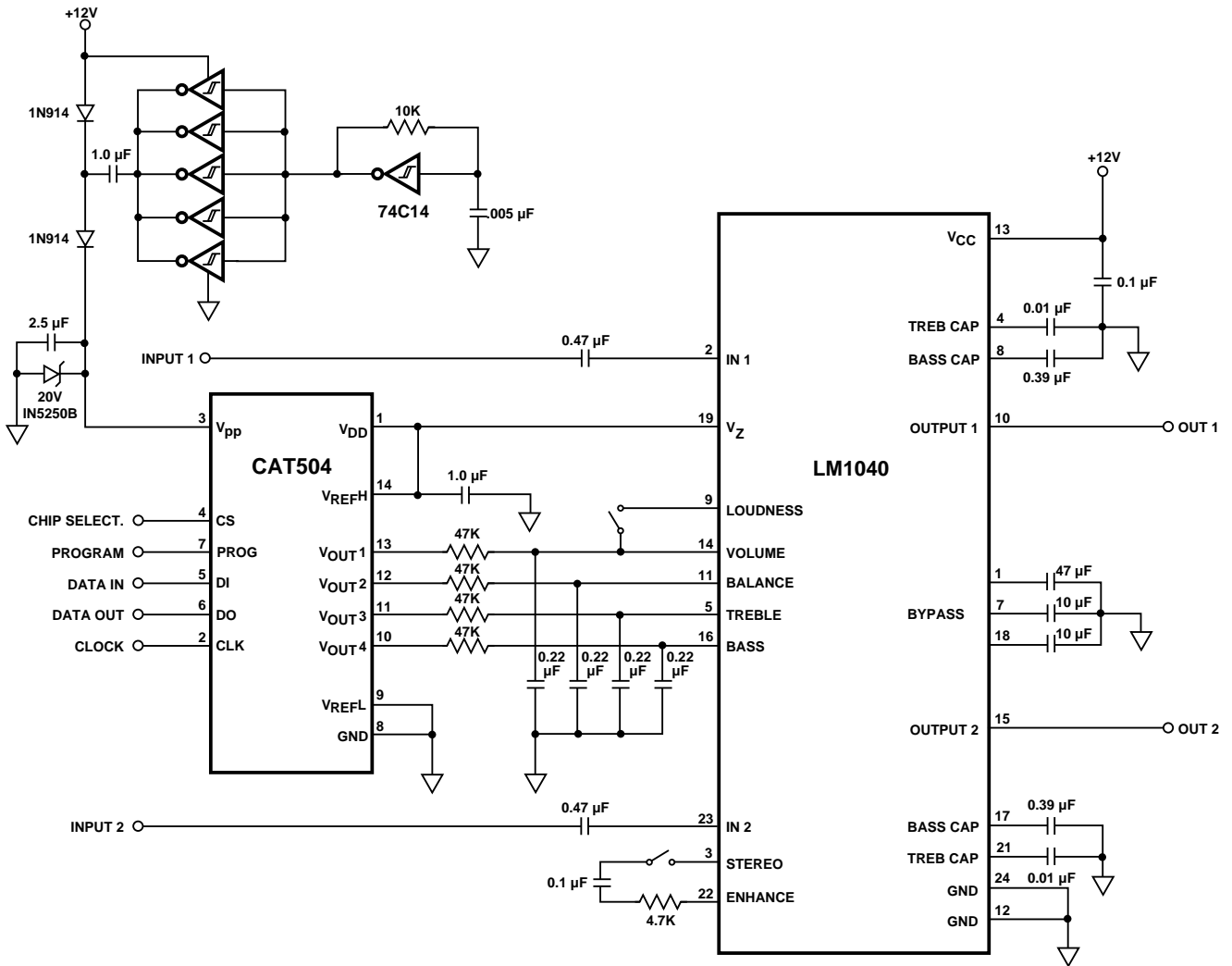

Digital Stereo Control

ORDERING INFORMATION

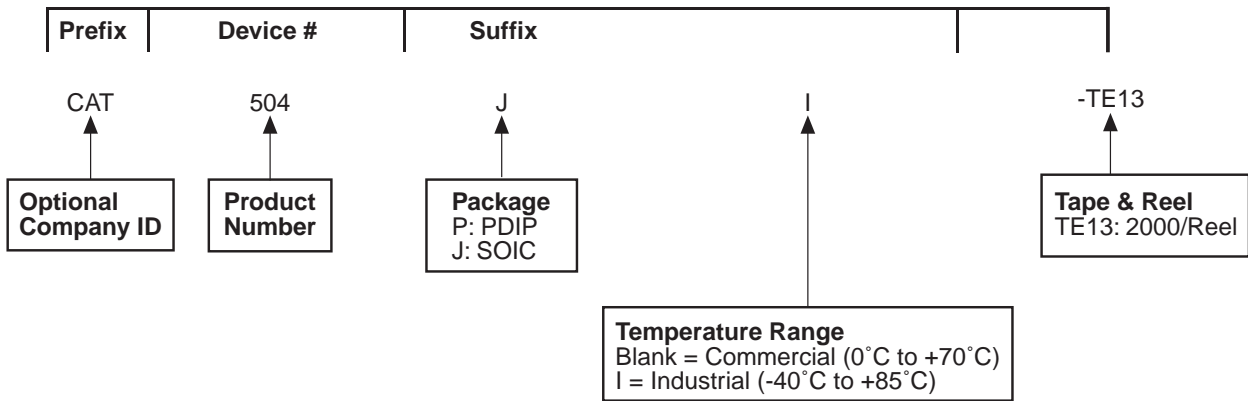

Notes:

(1) The device used in the above example is a CAT504JI-TE13 (SOIC, Industrial Temperature, Tape & Reel)