



CYPRESS

PRELIMINARY

W147G

Frequency Generator for Integrated Core Logic

Features

- Maximized EMI suppression using Cypress's Spread Spectrum Technology
- Low jitter and tightly controlled clock skew
- Highly integrated device providing clocks required for CPU, core logic, and SDRAM
- Three copies of CPU clock at 66/100 MHz
- Nine copies of 100-MHz SDRAM clocks
- Eight copies of PCI clock
- Two copies of synchronous APIC clock
- Two copies of 48-MHz clock (non-spread spectrum) optimized for USB reference input and video dot clock
- Two copies of 66-MHz fixed clock
- One copy of 14.31818-MHz reference clock
- Power-down control
- I²C interface for turning off unused clocks

Key Specifications

CPU, SDRAM Outputs Cycle-to-Cycle Jitter: 250 ps
 APIC, 48MHz, 3V66, PCI Outputs
 Cycle-to-Cycle Jitter: 500 ps
 APIC, 48MHz, SDRAM Output Skew: 250 ps
 CPU, 3V66 Output Skew: 175 ps
 PCI Output Skew: 500 ps
 CPU to SDRAM Skew (@ 100 MHz): 4.5 to 5.5 ns
 CPU to 3V66 Skew (@ 66 MHz): 7.0 to 8.0 ns
 3V66 to PCI Skew (3V66 lead): 1.5 to 3.5 ns
 PCI to APIC Skew: ±0.5 ns

Table 1. Pin Selectable Functions

SEL1	SEL0	Function
0	0	Three-state
0	1	Test
1	0	66-MHz CPU
1	1	100-MHz CPU

Block Diagram

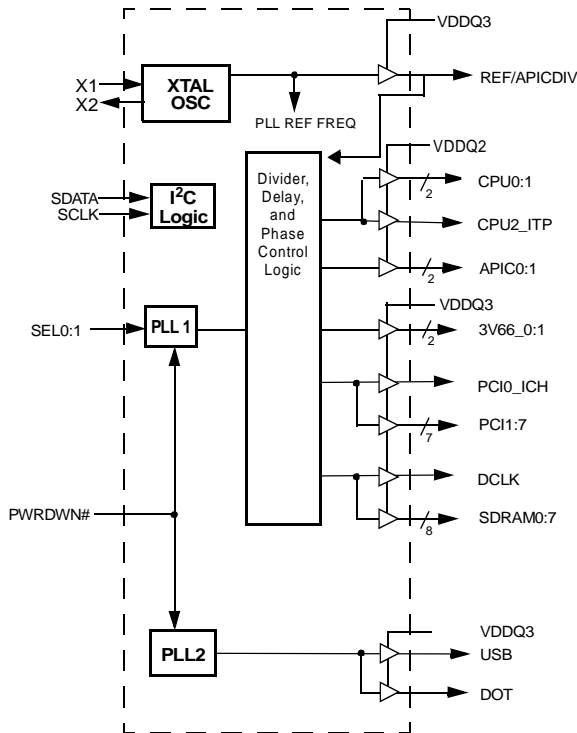

Pin Configuration

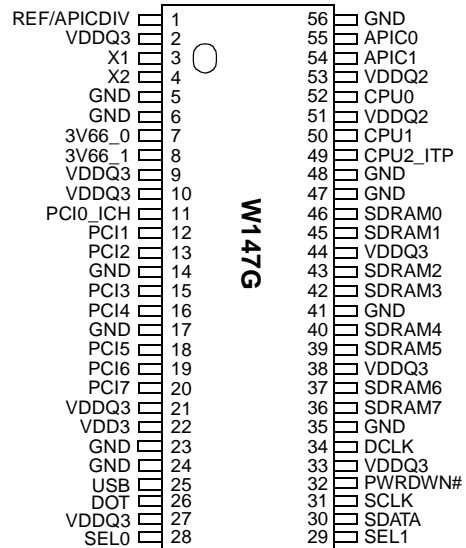

Pin Definitions

Pin Name	Pin No.	Pin Type	Pin Description
REF/APICDIV	1	I/O	Reference Clock: 3.3V 14.318-MHz clock output. This pin doubles as the select strap for APIC clock frequency. If strapped LOW during power up, APIC clock runs at half PCI clock speed. Otherwise, APIC clocks run at PCI clock speed.
X1	3	I	Crystal Input: This pin has dual functions. It can be used as an external 14.318-MHz crystal connection as an external reference frequency input.
X2	4	I	Crystal Output: An input connection for an external 14.318-MHz crystal. If using an external reference, this pin must be left unconnected.
PCI0_I _{CH} , PCI1:7	11, 12, 13, 15, 16, 18, 19, 20	O	PCI Clock 0 through 7: 3.3V 33-MHz PCI clock outputs. PCI1:7 can be individually turned off via I ² C interface.
3V66_0:1	7, 8	O	66-MHz Clock Output: 3.3V fixed 66-MHz clock.
USB	25	O	USB Clock Output: 3.3V fixed 48-MHz, non-spread spectrum USB clock outputs.
DOT	26	O	Dot Clock Output: 3.3V 48-MHz, non-spread spectrum signal.
SEL0:1	28, 29	I	Clock Function Selection pins: LVTTTL-compatible input to select device functions. See <i>Table 1</i> for detailed descriptions.
PWRDWN#	32	I	Power Down Control: LVTTTL-compatible asynchronous input that places the device in power-down mode when held LOW.
CPU2_I _{TP} , CPU0:1	49, 52, 50	O	CPU Clock Outputs: Clock outputs for the host bus interface and integrated test port. Output frequencies run at 66 MHz or 100 MHz depending on the configuration of SEL0:1. Voltage swing set by V _{DDQ2} .
SDRAM0:7, DCLK	46, 45, 43, 42, 40, 39, 37, 36, 34	O	SDRAM Clock Outputs: 3.3V outputs running at 100 MHz. SDRAM0:7 can be individually turned off via I ² C interface.
APIC0:1	55, 54	O	Synchronous APIC Clock Outputs: Clock outputs running divide synchronous with the PCI clock outputs. Output frequency is controlled by the strap option on REF. Voltage swing set by V _{DDQ2} .
SDATA	30	I/O	Data pin for I ² C circuitry.
SCLK	31	I	Clock pin for I ² C circuitry.
VDDQ3	2, 9, 10, 21, 27, 33, 38, 44	P	3.3V Power Connection: Power supply for SDRAM output buffers, PCI output buffers, 3V66 output buffers, reference output buffers, and 48-MHz output buffers. Connect to 3.3V.
VDD3	22	P	3.3V Power Connection: Power supply for core logic, PLL circuitry. Connect to 3.3V.
VDDQ2	51, 53	P	2.5V Power Connection: Power supply for IOAPIC and CPU output buffers. Connect to 2.5V or 3.3V.
GND	5, 6, 14, 17, 23, 24, 35, 41, 47, 48, 56	G	Ground Connections: Connect all ground pins to the common system ground plane.

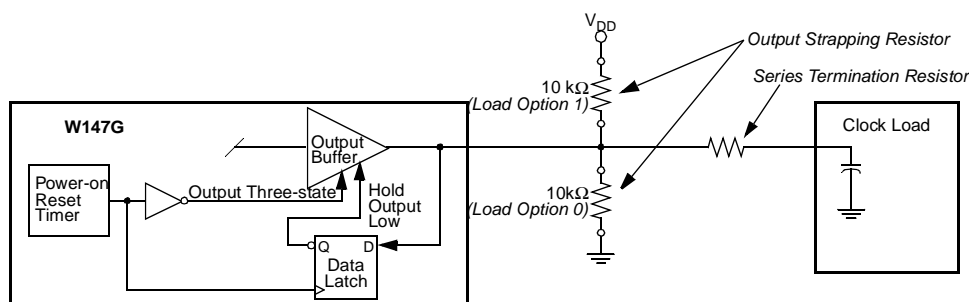

Figure 1. Input Logic Selection Through Resistor Load Option

Overview

The W147G is a highly integrated frequency timing generator, supplying all the required clock sources for an Intel® architecture platform using graphics integrated core logic.

Functional Description

I/O Pin Operation

REF/APICDIV is a dual purpose I/O pin. Upon power-up the pin acts as a logic input. If the pin is strapped to a LOW state externally, APIC clock outputs will run divide synchronously at half PCI clock speed. If it is pulled HIGH, APIC clock will run synchronous to PCI clocks. An external 10-kΩ strapping resistor should be used. *Figure 1* shows a suggested method for strapping resistor connections.

After 2 ms, the pin becomes an output. Assuming the power supply has stabilized by then, the specified output frequency is delivered on the pins. If the power supply has not yet reached full value, output frequency initially may be below target but will increase to target once supply voltage has stabilized. In either case, a short output clock cycle may be produced from the CPU clock outputs when the outputs are enabled.

Pin Selectable Functions

Table 1 outlines the device functions selectable through SEL0:1. Specific outputs available at each pin is detailed in *Table 2* below. The SEL0 pin requires a 220Ω pull-up resistor to 3.3V for the W147G to sense the maximum host bus frequency of the processor and configure itself accordingly.

Table 2. CK Whitney Truth Table

SEL1	SEL0	CPU	SDRAM	3V66	PCI	48MHz	REF	APIC ^[1]	Notes
0	0	Hi-Z	Hi-Z	Hi-Z	Hi-Z	Hi-Z	Hi-Z	Hi-Z	2
0	1	TCLK/2	TCLK/2	TCLK/3	TCLK/6	TCLK/2	TCLK	TCLK/6	4, 5
1	0	66 MHz	100 MHz	66 MHz	33 MHz	48 MHz	14.318 MHz	16.67 MHz	3, 6, 7
1	1	100 MHz	100 MHz	66 MHz	33 MHz	48 MHz	14.318 MHz	16.67 MHz	3, 6, 7

Notes:

1. APIC clock frequency determined by the strap option on the REF/APICDIV input pin.
2. Provided for board level "bed of nails" testing.
3. "Normal" mode of operation.
4. TCLK is a test clock overdriven on the XTAL_IN input during test mode.
5. Required for DC output impedance verification.
6. Range of reference frequency allowed is: min. = 14.316 MHz, nominal = 14.31818 MHz, max. = 14.32 MHz.
7. Frequency accuracy of 48 MHz must be +167 PPM to match USB default.

Offsets Among Clock Signal Groups

Figure 2 and Figure 3 represent the phase relationship among the different groups of clock outputs from W147G when it is providing a 66-MHz CPU clock and a 100-MHz CPU clock,

respectively. It should be noted that when CPU clock is operating at 100 MHz, CPU clock output is 180 degrees out of phase with SDRAM clock outputs.

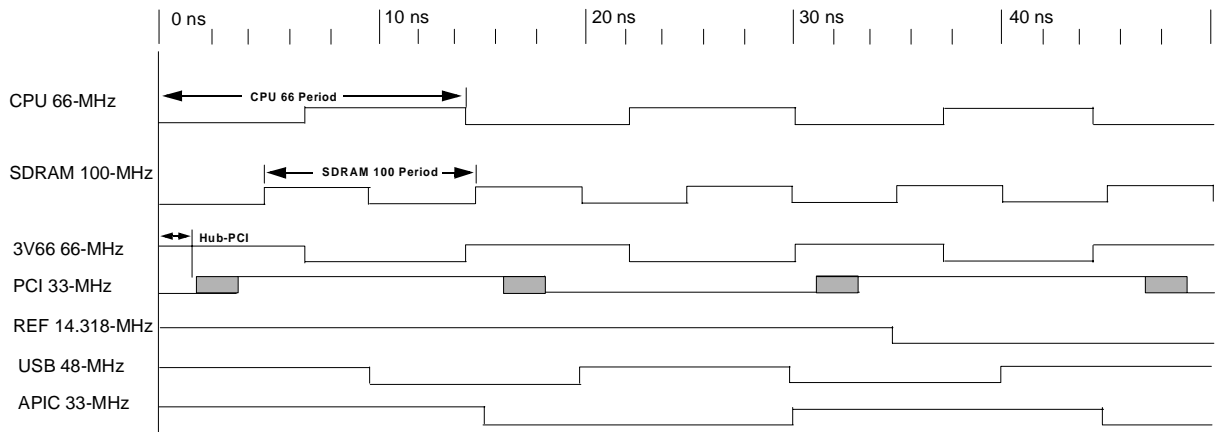

Figure 2. Group Offset Waveforms (66-MHz CPU Clock)

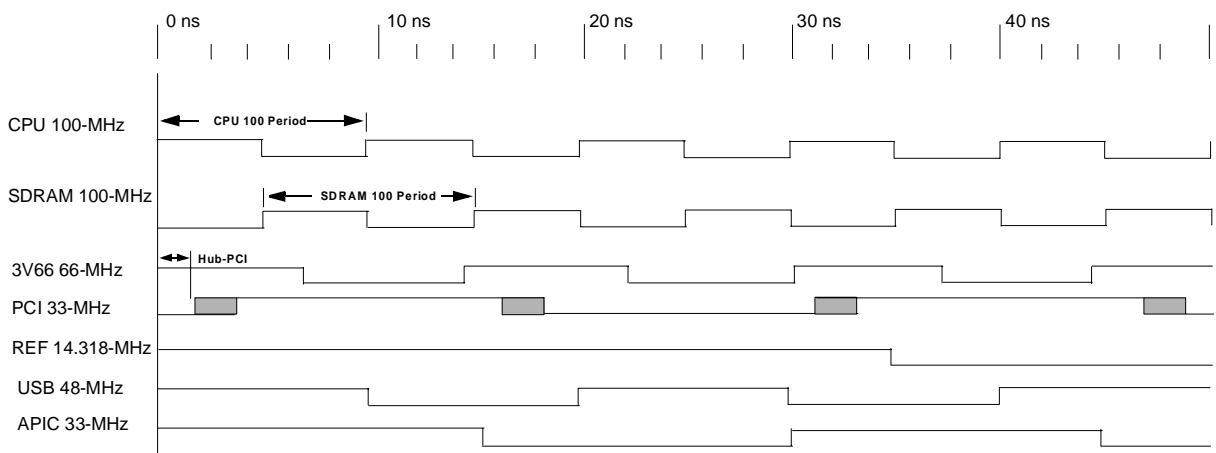

Figure 3. Group Offset Waveforms (100-MHz CPU Clock)

Power Down Control

W147G provides one PWRDWN# signal to place the device in low-power mode. In low-power mode, the PLLs are turned off and all clock outputs are driven LOW.

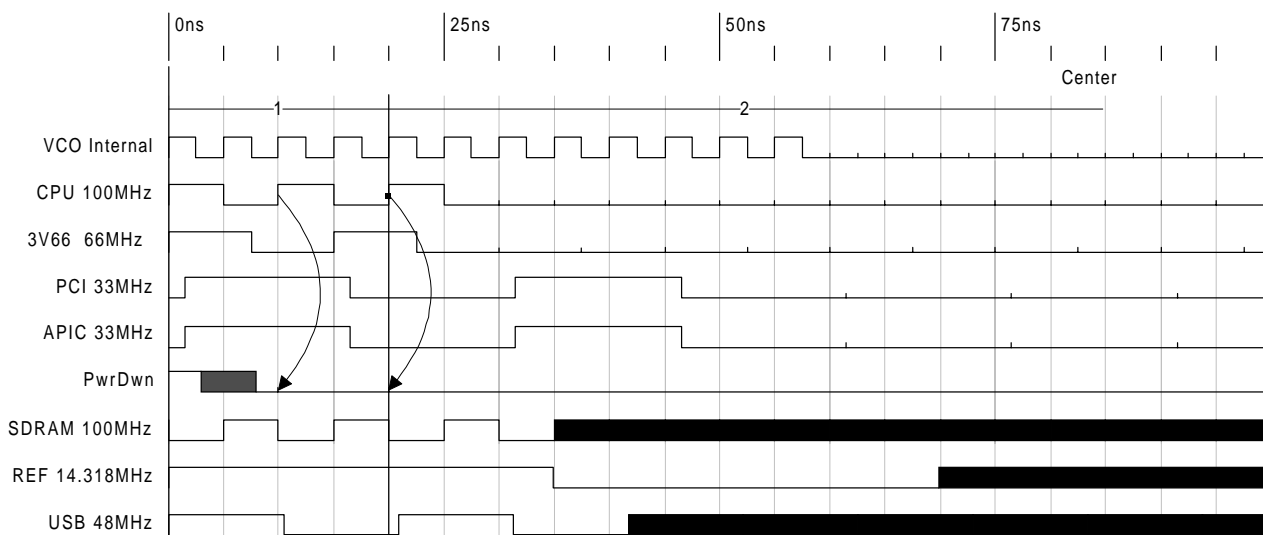

Figure 4. W147G PWRDWN# Timing Diagram^[8, 9, 10, 11]

Table 3. W147G Maximum Allowed Current

W147 Condition	Max. 2.5V supply consumption Max. discrete cap loads, $V_{DDQ2} = 2.625V$ All static inputs = V_{DDQ3} or V_{SS}	Max. 3.3V supply consumption Max. discrete cap loads $V_{DDQ3} = 3.465V$ All static inputs = V_{DDQ3} or V_{SS}
Powerdown Mode (PWRDWN# = 0)	100 μA	200 μA
Full Active 66 MHz SEL1,0 = 10 (PWRDWN# = 1)	70 mA	280 mA
Full Active 100 MHz SEL1,0 = 11 (PWRDWN# = 1)	100 mA	280 mA

Notes:

8. Once the PWRDWN# signal is sampled LOW for two consecutive rising edges of CPU clock, clocks of interest should be held LOW on the next HIGH-to-LOW transition.
9. PWR_DWN# is an asynchronous input and metastable conditions could exist. This signal is synchronized inside W147G.
10. The shaded sections on the SDRAM, REF, and USB clocks indicate "don't care" states.
11. Diagrams shown with respect to 100 MHz. Similar operation when CPU is 66 MHz.

Spread Spectrum Clocking

The device generates a clock that is frequency modulated in order to increase the bandwidth that it occupies. By increasing the bandwidth of the fundamental and its harmonics, the amplitudes of the radiated electromagnetic emissions are reduced. This effect is depicted in *Figure 5*.

As shown in *Figure 5*, a harmonic of a modulated clock has a much lower amplitude than that of an unmodulated signal. The reduction in amplitude is dependent on the harmonic number and the frequency deviation or spread. The equation for the reduction is

$$dB = 6.5 + 9 \cdot \log_{10}(P) + 9 \cdot \log_{10}(F)$$

Where P is the percentage of deviation and F is the frequency in MHz where the reduction is measured.

The output clock is modulated with a waveform depicted in *Figure 6*. This waveform, as discussed in "Spread Spectrum Clock Generation for the Reduction of Radiated Emissions" by Bush, Fessler, and Hardin produces the maximum reduction in the amplitude of radiated electromagnetic emissions. The deviation selected for this chip is -0.5% of the selected frequency. *Figure 6* details the Cypress spreading pattern. Cypress does offer options with more spread and greater EMI reduction. Contact your local Sales representative for details on these devices.

Spread Spectrum clocking is activated or deactivated by selecting the appropriate value for bit 3 in data byte 0 of the I²C data stream. Refer to page 8 for more details.

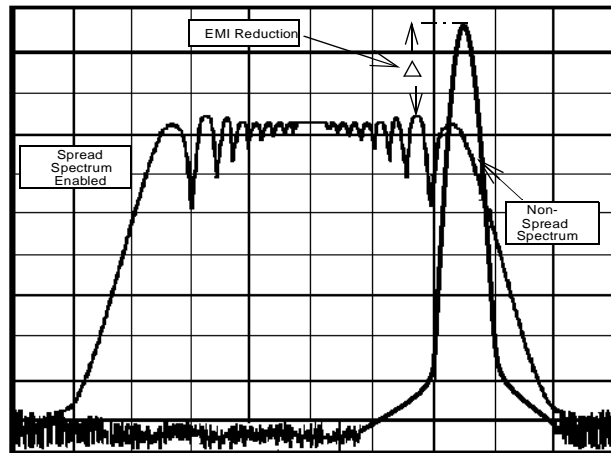

Figure 5. Typical Clock and SSFTG Comparison

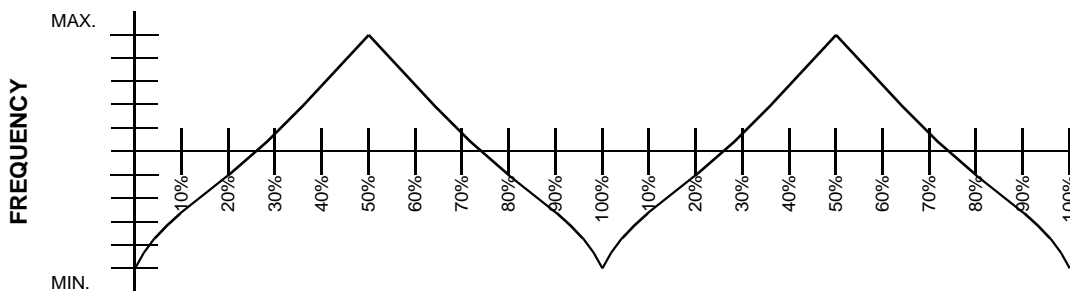
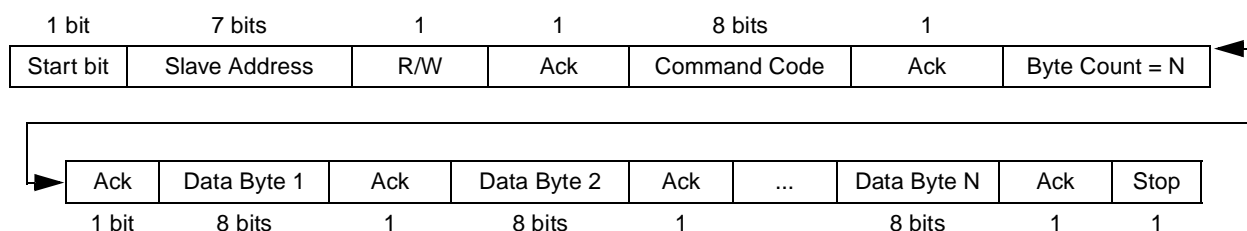

Figure 6. Typical Modulation Profile

Figure 7. An Example of a Block Write^[12]
Serial Data Interface

The W147G features a two-pin, serial data interface that can be used to configure internal register settings that control particular device functions.

Data Protocol

The clock driver serial protocol accepts only block writes from the controller. The bytes must be accessed in sequential order from lowest to highest byte with the ability to stop after any complete byte has been transferred. Indexed bytes are not allowed.

A block write begins with a slave address and a write condition. After the command code the core logic issues a byte count which describes how many more bytes will follow in the message. If the host had 20 bytes to send, the first byte would be the number 20 (14h), followed by the 20 bytes of data. The byte count may not be 0. A block write command is allowed to trans-

fer a maximum of 32 data bytes. The slave receiver address for W147G is 11010010. *Figure 7* shows an example of a block write.

The command code and the byte count bytes are required as the first two bytes of any transfer. W147G expects a command code of 0000 0000. The byte count byte is the number of additional bytes required for the transfer, not counting the command code and byte count bytes. Additionally, the byte count byte is required to be a minimum of 1 byte and a maximum of 32 bytes to satisfy the above requirement. *Table 4* shows an example of a possible byte count value.

A transfer is considered valid after the acknowledge bit corresponding to the byte count is read by the controller. The command code and byte count bytes are ignored by the W147G. However, these bytes must be included in the data write sequence to maintain proper byte allocation.

Table 4. Example of Possible Byte Count Value

Byte Count Byte		Notes
MSB	LSB	
0000	0000	Not allowed. Must have at least one byte.
0000	0001	Data for functional and frequency select register (currently byte 0 in spec)
0000	0010	Reads first two bytes of data. (byte 0 then byte 1)
0000	0011	Reads first three bytes (byte 0, 1, 2 in order)
0000	0100	Reads first four bytes (byte 0, 1, 2, 3 in order)
0000	0101	Reads first five bytes (byte 0, 1, 2, 3, 4 in order) ^[13]
0000	0110	Reads first six bytes (byte 0, 1, 2, 3, 4, 5 in order) ^[13]
0000	0111	Reads first seven bytes (byte 0, 1, 2, 3, 4, 5, 6 in order)
0010	0000	Max byte count supported = 32

Table 5. Serial Data Interface Control Functions Summary

Control Function	Description	Common Application
Output Disable	Any individual clock output(s) can be disabled. Disabled outputs are actively held LOW.	Unused outputs are disabled to reduce EMI and system power. Examples are clock outputs to unused PCI slots.
Spread Spectrum Enabling	Enables or disables spread spectrum clocking.	For EMI reduction.
(Reserved)	Reserved function for future device revision or production device testing.	No user application. Register bit must be written as 0.

Notes:

12. The acknowledgment bit is returned by the slave/receiver (W147G).
 13. Data Bytes 3 to 7 are reserved.



W147G Serial Configuration Map

1. The serial bits will be read by the clock driver in the following order:

Byte 0 - Bits 7, 6, 5, 4, 3, 2, 1, 0

Byte 1 - Bits 7, 6, 5, 4, 3, 2, 1, 0

Byte N - Bits 7, 6, 5, 4, 3, 2, 1, 0

2. All unused register bits (reserved and N/A) should be written to a "0" level.

3. All register bits labeled "Initialize to 0" must be written to zero during initialization. Failure to do so may result in higher than normal operating current.

4. Only Byte 0, 1 and 2 are defined in W147G Byte 3 to Byte 7 are reserved and must be written to "zero."

Byte 0: Control Register (1 = Enable, 0= Disable)^[14]

Bit	Pin#	Name	Pin Description
Bit 7	-	Reserved	(Active/Inactive)
Bit 6	-	Reserved	(Active/Inactive)
Bit 5	-	Reserved	(Active/Inactive)
Bit 4	-	Reserved	(Active/Inactive)
Bit 3	-	Spread Spectrum (1=On/0=Off)	(Active/Inactive)
Bit 2	26	DOT	(Active/Inactive)
Bit 1	25	USB	(Active/Inactive)
Bit 0	49	CPU2_ITP	(Active/Inactive)

Byte 1: Control Register (1 = Enable, 0= Disable)^[14]

Bit	Pin#	Name	Pin Description
Bit 7	36	SDRAM7	(Active/Inactive)
Bit 6	37	SDRAM6	(Active/Inactive)
Bit 5	39	SDRAM5	(Active/Inactive)
Bit 4	40	SDRAM4	(Active/Inactive)
Bit 3	42	SDRAM3	(Active/Inactive)
Bit 2	43	SDRAM2	(Active/Inactive)
Bit 1	45	SDRAM1	(Active/Inactive)
Bit 0	46	SDRAM0	(Active/Inactive)

Byte 2: Control Register (1 = Enable, 0= Disable)^[14]

Bit	Pin#	Name	Pin Description
Bit 7	20	PCI7	(Active/Inactive)
Bit 6	19	PCI6	(Active/Inactive)
Bit 5	18	PCI5	(Active/Inactive)
Bit 4	16	PCI4	(Active/Inactive)
Bit 3	15	PCI3	(Active/Inactive)
Bit 2	13	PCI2	(Active/Inactive)
Bit 1	12	PCI1	(Active/Inactive)
Bit 0	-	Reserved	(Active/Inactive)

Note:

14. Inactive means outputs are held LOW and are disabled from switching. These outputs are designed to be configured at power-on and are not expected to be configured during the normal modes of operation.



DC Electrical Characteristics

DC parameters must be sustainable under steady state (DC) conditions.

Absolute Maximum DC Power Supply

Parameter	Description	Min.	Max.	Unit
V _{DD3}	3.3V Core Supply Voltage	-0.5	4.6	V
V _{DDQ2}	2.5V I/O Supply Voltage	-0.5	3.6	V
V _{DDQ3}	3.3V Supply Voltage	-0.5	4.6	V
T _S	Storage Temperature	-65	150	°C

Absolute Maximum DC I/O

Parameter	Description	Min.	Max.	Unit
V _{ih3}	3.3V Input High Voltage	-0.5	4.6	V
V _{il3}	3.3V Input Low Voltage	-0.5		V
ESD prot.	Input ESD Protection	2000		V

DC Operating Requirements

Parameter	Description	Condition	Min.	Max.	Unit
V _{DD3}	3.3V Core Supply Voltage	3.3V±5%	3.135	3.465	V
V _{DDQ3}	3.3V I/O Supply Voltage	3.3V±5%	3.135	3.465	V
V _{DDQ2}	2.5V I/O Supply Voltage	2.5V±5%	2.375	2.625	V
V _{DD3} = 3.3V±5%					
V _{ih3}	3.3V Input High Voltage	V _{DD3}	2.0	V _{DD} +0.3	V
V _{il3}	3.3V Input Low Voltage		V _{SS} -0.3	0.8	V
I _{il}	Input Leakage Current ^[15]	0<V _{in} <V _{DDQ3}	-5	+5	µA
V _{DDQ2} = 2.5V±5%					
V _{oh2}	2.5V Output High Voltage	I _{oh} =(-1 mA)	2.0		V
V _{ol2}	2.5V Output Low Voltage	I _{ol} =(1 mA)		0.4	V
V _{DDQ3} = 3.3V±5%					
V _{oh3}	3.3V Output High Voltage	I _{oh} =(-1 mA)	2.4		V
V _{ol3}	3.3V Output Low Voltage	I _{ol} =(1 mA)		0.4	V
V _{DDQ3} = 3.3V±5%					
V _{poh3}	PCI Bus Output High Voltage	I _{oh} =(-1 mA)	2.4		V
V _{pol3}	PCI Bus Output Low Voltage	I _{ol} =(1 mA)		0.55	V
C _{in}	Input Pin Capacitance			5	pF
C _{xtal}	Xtal Pin Capacitance		13.5	22.5	pF
C _{out}	Output Pin Capacitance			6	pF
L _{pin}	Pin Inductance		0	7	nH
T _a	Ambient Temperature	No Airflow	0	70	°C

Note:

15. Input Leakage Current does not include inputs with pull-up or pull-down resistors.



AC Electrical Characteristics

T_A = 0°C to +70°C, V_{DDQ3} = 3.3V±5%, V_{DDQ2} = 2.5V±5%

f_{XTL} = 14.31818 MHz

Spread Spectrum function turned off

AC clock parameters are tested and guaranteed over stated operating conditions using the stated lump capacitive load at the clock output.^[16]

Parameter	Description	66.6-MHz Host		100-MHz Host		Unit	Notes
		Min.	Max.	Min.	Max.		
T _{Period}	Host/CPUCLK Period	15.0	15.5	10.0	10.5	ns	16
T _{HIGH}	Host/CPUCLK High Time	5.2	N/A	3.0	N/A	ns	19
T _{LOW}	Host/CPUCLK Low Time	5.0	N/A	2.8	N/A	ns	20
T _{RISE}	Host/CPUCLK Rise Time	0.4	1.6	0.4	1.6	ns	
T _{FALL}	Host/CPUCLK Fall Time	0.4	1.6	0.4	1.6	ns	
T _{Period}	SDRAM CLK Period	10.0	10.5	10.0	10.5	ns	16
T _{HIGH}	SDRAM CLK High Time	3.0	N/A	3.0	N/A	ns	19
T _{LOW}	SDRAM CLK Low Time	2.8	N/A	2.8	N/A	ns	20
T _{RISE}	SDRAM CLK Rise Time	0.4	1.6	0.4	1.6	ns	
T _{FALL}	SDRAM CLK Fall Time	0.4	1.6	0.4	1.6	ns	
T _{Period}	APIC CLK Period	60.0	64.0	60.0	64.0	ns	16
T _{HIGH}	APIC CLK High Time	25.5	N/A	25.5	N/A	ns	19
T _{LOW}	APIC CLK Low Time	25.3	N/A	25.3	N/A	ns	20
T _{RISE}	APIC CLK Rise Time	0.4	1.6	0.4	1.6	ns	
T _{FALL}	APIC CLK Fall Time	0.4	1.6	0.4	1.6	ns	
T _{Period}	3V66 CLK Period	15.0	16.0	15.0	16.0	ns	16, 18
T _{HIGH}	3V66 CLK High Time	5.25	N/A	5.25	N/A	ns	19
T _{LOW}	3V66 CLK Low Time	5.05	N/A	5.05	N/A	ns	20
T _{RISE}	3V66 CLK Rise Time	0.5	2.0	0.5	2.0	ns	
T _{FALL}	3V66 CLK Fall Time	0.5	2.0	0.5	2.0	ns	
T _{Period}	PCI CLK Period	30.0	N/A	30.0	N/A	ns	16, 17
T _{HIGH}	PCI CLK High Time	12.0	N/A	12.0	N/A	ns	19
T _{LOW}	PCI CLK Low Time	12.0	N/A	12.0	N/A	ns	20
T _{RISE}	PCI CLK Rise Time	0.5	2.0	0.5	2.0	ns	
T _{FALL}	PCI CLK Fall Time	0.5	2.0	0.5	2.0	ns	
t _{pZL} , t _{pZH}	Output Enable Delay (All outputs)	1.0	10.0	1.0	10.0	ns	
t _{pLZ} , t _{pZH}	Output Disable Delay (All outputs)	1.0	10.0	1.0	10.0	ns	
t _{stable}	All Clock Stabilization from Power-Up		3		3	ms	

Notes:

- 16. Period, jitter, offset, and skew measured on rising edge at 1.25 for 2.5V clocks and at 1.5V for 3.3V clocks.
- 17. T_{HIGH} is measured at 2.0V for 2.5V outputs, 2.4V for 3.3V outputs.
- 18. T_{LOW} is measured at 0.4V for all outputs.
- 19. The time specified is measured from when V_{DDQ3} achieves its nominal operating level (typical condition V_{DDQ3} = 3.3V) until the frequency output is stable and operating within specification.
- 20. T_{RISE} and T_{FALL} are measured as a transition through the threshold region V_{ol} = 0.4V and V_{oh} = 2.0V (1 mA) JEDEC specification.

Group Skew and Jitter Limits

Output Group	Pin-Pin Skew Max	Cycle-Cycle Jitter	Duty Cycle	Nom Vdd	Skew, Jitter Measure Point
CPU	175 ps	250 ps	45/55	2.5V	1.25V
SDRAM	250 ps	250 ps	45/55	3.3V	1.5V
APIC	250 ps	500 ps	45/55	2.5V	1.25V
48MHz	250 ps	500 ps	45/55	3.3V	1.5V
3V66	175 ps	500 ps	45/55	3.3V	1.5V
PCI	500 ps	500 ps	45/55	3.3V	1.5V
REF	N/A	1000 ps	45/55	3.3V	1.5V

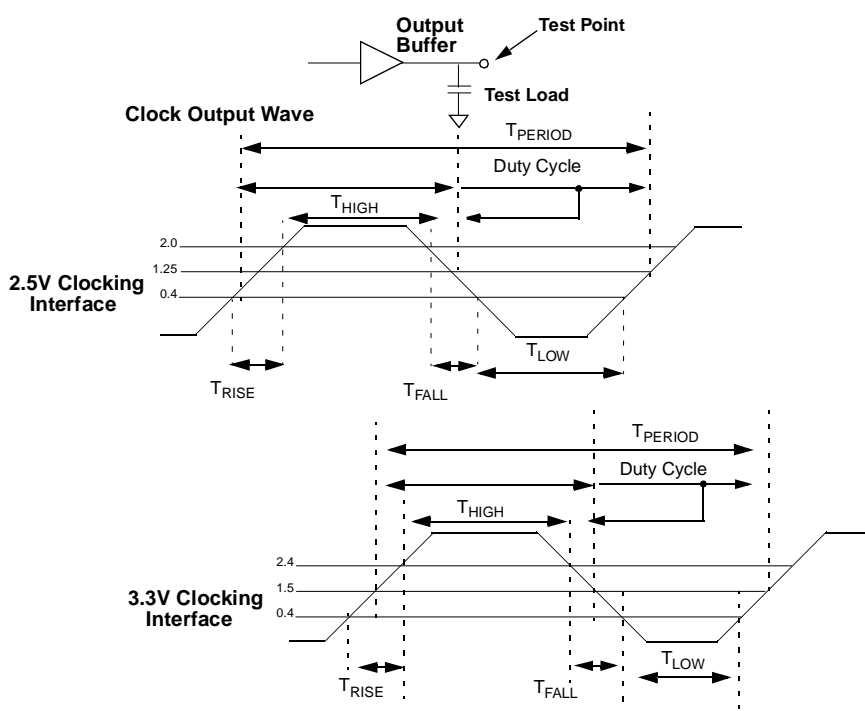
Figure 8. Output Buffer
Ordering Information

Ordering Code	Package Name	Package Type
W147G	H	56-pin SSOP (300 mils)

Intel is a registered trademark of Intel Corporation.

Document #: 38-00820

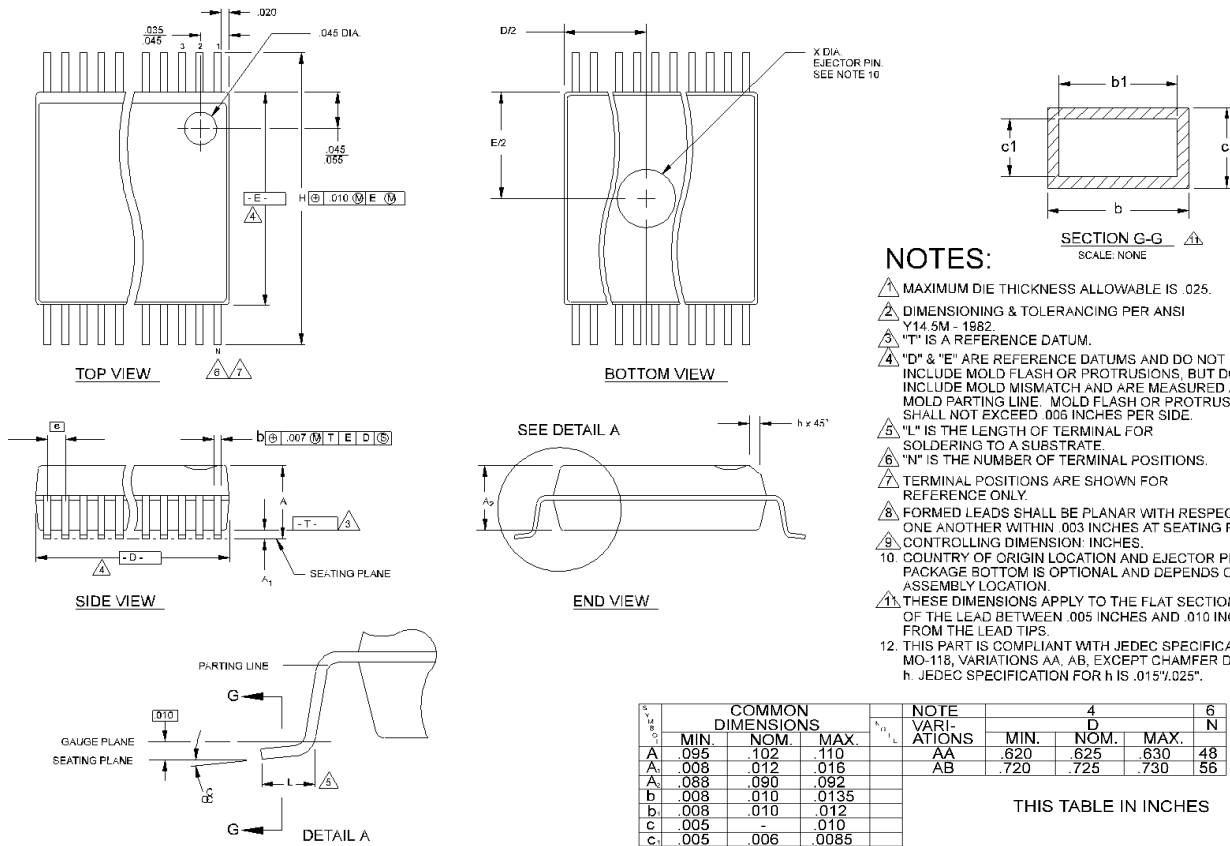
Package Diagram
56-Pin Shrink Small Outline Package (SSOP, 300 mils)

NOTES:

1. MAXIMUM DIE THICKNESS ALLOWABLE IS .025.
2. DIMENSIONING & TOLERANCING PER ANSI Y14.5M - 1982.
3. "T" IS A REFERENCE DATUM.
4. "D" & "E" ARE REFERENCE DATUMS AND DO NOT INCLUDE MOLD FLASH OR PROTRUSIONS, BUT DOES INCLUDE MOLD MISMATCH AND ARE MEASURED AT THE MOLD PARTING LINE. MOLD FLASH OR PROTRUSIONS SHALL NOT EXCEED .005 INCHES PER SIDE.
5. "L" IS THE LENGTH OF TERMINAL FOR SOLDERING TO A SUBSTRATE.
6. "N" IS THE NUMBER OF TERMINAL POSITIONS.
7. TERMINAL POSITIONS ARE SHOWN FOR REFERENCE ONLY.
8. FORMED LEADS SHALL BE PLANAR WITH RESPECT TO ONE ANOTHER WITHIN .003 INCHES AT SEATING PLANE.
9. CONTROLLING DIMENSION: INCHES.
10. COUNTRY OF ORIGIN LOCATION AND EJECTOR PIN ON PACKAGE BOTTOM IS OPTIONAL AND DEPENDS ON ASSEMBLY LOCATION.
11. THESE DIMENSIONS APPLY TO THE FLAT SECTION OF THE LEAD BETWEEN .005 INCHES AND .010 INCHES FROM THE LEAD TIPS.
12. THIS PART IS COMPLIANT WITH JEDEC SPECIFICATION MO-118, VARIATIONS AA, AB, EXCEPT CHAMFER DIMENSION h. JEDEC SPECIFICATION FOR h IS .0157(.025").

Summary of nominal dimensions in inches:

Body Width: 0.296
Lead Pitch: 0.025
Body Length: 0.625
Body Height: 0.102

S Y E I	COMMON DIMENSIONS			NOTE VARIATIONS	4 D N		
	MIN.	NOM.	MAX.		MIN.	NOM.	MAX.
A	.095	.102	.110	AA	.620	.625	.630
A ₁	.088	.090	.092	AB	.720	.725	.730
b	.008	.010	.0135				
b ₁	.008	.010	.012				
c	.005	-	.010				
c ₁	.005	.006	.0085				
D	SEE VARIATIONS			4			
E	.292	.296	.299				
e	.025 BSC						
H	.400	.406	.410				
h	.010	.013	.016				
L	.024	.032	.040				
N	SEE VARIATIONS			6			
X	.085	.093	.100	10			
α	0°	5°	8°				

THIS TABLE IN INCHES

S Y E I	COMMON DIMENSIONS			NOTE VARIATIONS	4 D N		
	MIN.	NOM.	MAX.		MIN.	NOM.	MAX.
A	2.41	2.59	2.79	AA	15.75	15.88	16.00
A ₁	0.20	0.31	0.41	AB	18.29	18.42	18.54
b	0.203	0.254	0.343				
b ₁	0.203	0.254	0.305				
c	0.127	-	0.254				
c ₁	0.127	0.152	0.216				
D	SEE VARIATIONS			4			
E	7.42	7.52	7.59				
e	0.635 BSC						
H	10.16	10.31	10.41				
h	0.25	0.33	0.41				
L	0.61	0.81	1.02				
N	SEE VARIATIONS			6			
X	2.16	2.36	2.54	10			
α	0°	5°	8°				

THIS TABLE IN MILLIMETERS