



CY7C168A

4Kx4 RAM

Features

- Automatic power-down when deselected
- CMOS for optimum speed/power
- High speed
 - $t_{AA} = 15 \text{ ns}$
- Low active power
 - 633 mW
- Low standby power
 - 110 mW
- TTL-compatible inputs and outputs
- V_{IH} of 2.2V
- Capable of withstanding greater than 2001V electrostatic discharge

Functional Description

The CY7C168A is a high-performance CMOS static RAM organized as 4096 by 4 bits. Easy memory expansion is provided by an active LOW Chip Enable (\overline{CE}) and three-state drivers. The CY7C168A has an automatic power-down feature, reducing the power consumption by 77% when deselected.

Writing to the device is accomplished when the Chip Select (\overline{CE}) and Write Enable (\overline{WE}) inputs are both LOW. Data on the four data input/output pins (I/O_0 through I/O_3) is written into the memory location specified on the address pins (A_0 through A_{11}).

Reading the device is accomplished by taking the Chip Enable (\overline{CE}) LOW, while Write Enable (\overline{WE}) remains HIGH. Under these conditions, the contents of the location specified on the address pins will appear on the four data input/output pins (I/O_0 through I/O_3).

The input/output pins remain in a high-impedance state when Chip Enable (\overline{CE}) is HIGH or Write Enable (\overline{WE}) is LOW.

A die coat is used to insure alpha immunity.

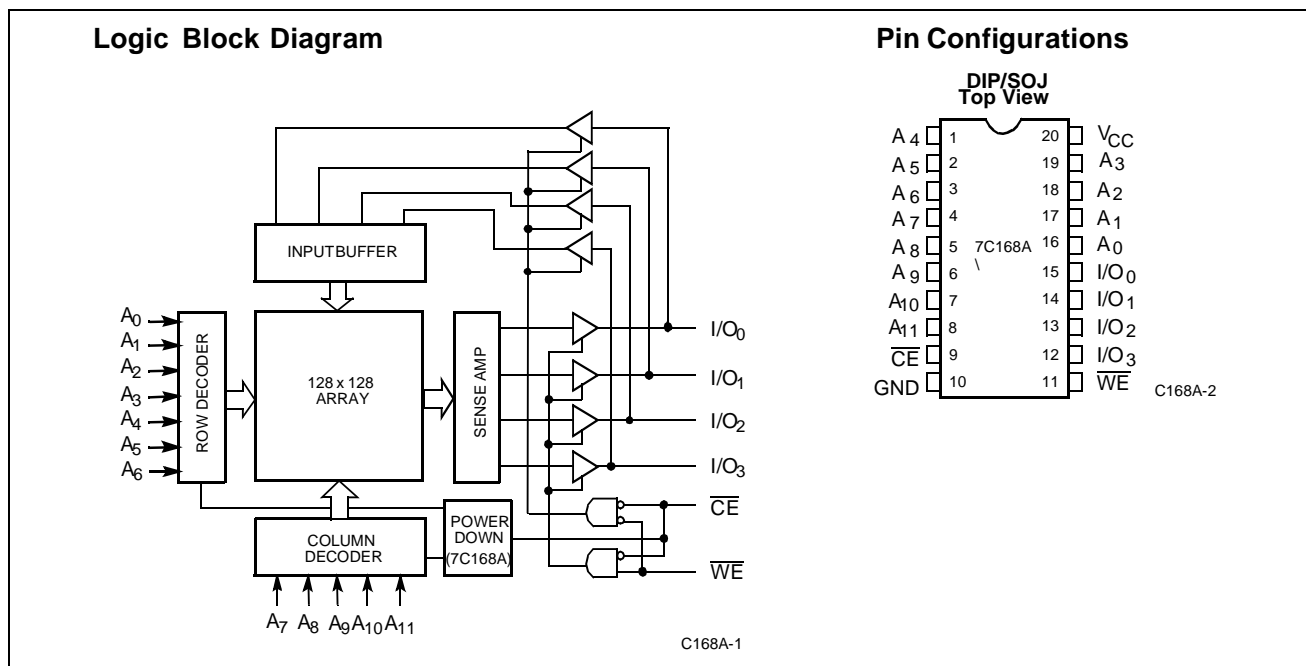

Selection Guide

		7C168A-15	7C168A-20	7C168A-25	7C168A-35	7C168A-45
Maximum Access Time (ns)		15	20	25	35	45
Maximum Operating Current (mA)	Commercial	115	90	90	90	90
	Military	-	100	100	100	100



Maximum Ratings

(Above which the useful life may be impaired. For user guidelines, not tested.)

- Storage Temperature -65°C to +150°C
- Ambient Temperature with Power Applied -55°C to +125°C
- Supply Voltage to Ground Potential (Pin 20 to Pin 10) -0.5V to +7.0V
- DC Voltage Applied to Outputs in High Z State -0.5V to +7.0V
- DC Input Voltage -3.0V to +7.0V

- Output Current into Outputs (Low) 20 mA
- Static Discharge Voltage >2001V (per MIL-STD-883, Method 3015)
- Latch-Up Current >200 mA

Operating Range

Range	Ambient Temperature	V _{CC}
Commercial	0°C to +70°C	5V ± 10%
Military ^[1]	-55°C to +125°C	5V ± 10%

Electrical Characteristics Over the Operating Range^[2]

Parameter	Description	Test Conditions	7C168A-15		7C168A-20		Unit
			Min.	Max.	Min.	Max.	
V _{OH}	Output HIGH Voltage	V _{CC} = Min., I _{OH} = -4.0 mA	2.4		2.4		V
V _{OL}	Output LOW Voltage	V _{CC} = Min., I _{OL} = 8.0 mA		0.4		0.4	V
V _{IH}	Input HIGH Voltage		2.2	V _{CC}	2.2	V _{CC}	V
V _{IL}	Input LOW Voltage ^[3]		-0.5	0.8	-0.5	0.8	V
I _{Ix}	Input Load Current	GND ≤ V _I ≤ V _{CC}	-10	+10	-10	+10	μA
I _{OZ}	Output Leakage Current	GND ≤ V _O ≤ V _{CC} , Output Disabled	-10	+10	-10	+10	μA
I _{OS}	Output Short Circuit Current ^[4]	V _{CC} = Max., V _{OUT} = GND		-350		-350	mA
I _{CC}	V _{CC} Operating Supply Current	V _{CC} = Max., I _{OUT} = 0 mA	Com'l	115		90	mA
			Mil	-		100	
I _{SB1}	Automatic \overline{CE} Power-Down Current	Max. V _{CC} , $\overline{CE} \geq V_{IH}$	Com'l	40		40	mA
			Mil	-		40	
I _{SB2}	Automatic \overline{CE} Power-Down Current	Max. V _{CC} , $\overline{CE} \geq V_{CC} - 0.3V$	Com'l	20		20	mA
			Mil	-		20	

Notes:

1. T_A is the "instant on" case temperature.
2. See the last page of this specification for Group A subgroup testing information.
3. V_{IL} min. = -3.0V for pulse durations less than 30 ns.
4. Not more than 1 output should be shorted at one time. Duration of the short circuit should not exceed 30 seconds.

Electrical Characteristics Over the Operating Range^[2] (continued)

Parameter	Description	Test Conditions	7C168A-25		7C168A-35		7C168A-45		Unit
			Min.	Max.	Min.	Max.	Min.	Max.	
V _{OH}	Output HIGH Voltage	V _{CC} = Min., I _{OH} = -4.0 mA	2.4		2.4		2.4		V
V _{OL}	Output LOW Voltage	V _{CC} = Min., I _{OL} = 8.0 mA		0.4		0.4		0.4	V
V _{IH}	Input HIGH Voltage		2.2	V _{CC}	2.2	V _{CC}	2.2	V _{CC}	V
V _{IL}	Input LOW Voltage ^[3]		-0.5	0.8	-0.5	0.8	-0.5	0.8	V
I _{Ix}	Input Load Current	GND ≤ V _I ≤ V _{CC}	-10	+10	-10	10	-10	10	μA
I _{OZ}	Output Leakage Current	GND ≤ V _O ≤ V _{CC} Output Disabled	-10	+10	-50	50	-50	50	μA
I _{OS}	Output Short Circuit Current ^[4]	V _{CC} = Max., V _{OUT} = GND		-350		-350		-350	mA
I _{CC}	V _{CC} Operating Supply Current	V _{CC} = Max., I _{OUT} = 0 mA	Com'l	90		90		90	mA
			Mil		100		100		
I _{SB1}	Automatic \overline{CE} Power-Down Current	Max. V _{CC} , CE ≥ V _{IH}	Com'l	20		20		20	mA
			Mil		20		20		
I _{SB2}	Automatic \overline{CE} Power-Down Current	Max. V _{CC} , CE ≥ V _{CC} - 0.3 V	Com'l	20		20		20	mA
			Mil		20		20		

Capacitance^[5]

Parameter	Description	Test Conditions	Max.	Unit
C _{IN}	Input Capacitance	T _A = 25°C, f = 1 MHz, V _{CC} = 5.0V	10	pF
C _{OUT}	Output Capacitance		10	pF

Note:

5. Tested initially and after any design or process changes that may affect these parameters.

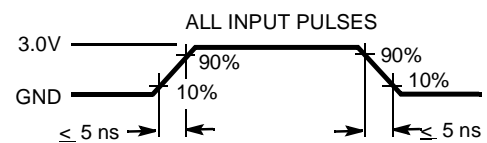
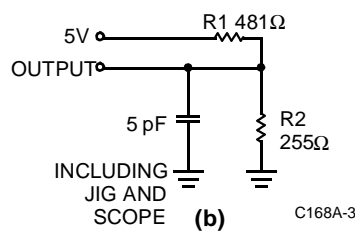
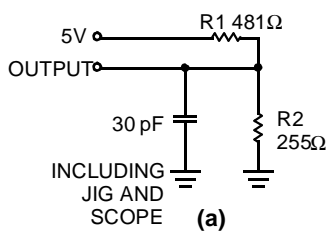
AC Test Loads and Waveforms

C168A-4

Equivalent to: THÉVENIN EQUIVALENT

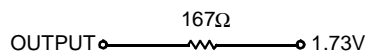

Switching Characteristics Over the Operating Range^[2,6]

Parameter	Description	7C168A-15		7C168A-20		7C168A-25		7C168A-35		7C168A-45		Unit
		Min.	Max.	Min.	Max.	Min.	Max.	Min.	Max.	Min.	Max.	
READ CYCLE												
t_{RC}	Read Cycle Time	15		20		25		35		45		ns
t_{AA}	Address to Data Valid		15		20		25		35		45	ns
t_{OHA}	Output Hold from Address Change	5		5		5		5		5		ns
t_{ACE}	Power Supply Current		15		20		25		35		45	ns
t_{LZCE}	\overline{CE} LOW to Low Z ^[7]	5		5		5		5		5		ns
t_{HZCE}	\overline{CE} HIGH to High Z ^[7, 8]		8		8		10		15		15	ns
t_{PU}	\overline{CE} LOW to Power Up	0		0		0		0		0		ns
t_{PD}	\overline{CE} HIGH to Power-Down		15		20		20		20		25	ns
t_{RCS}	Read Command Set-Up	0		0		0		0		0		ns
t_{RCH}	Read Command Hold	0		0		0		0		0		ns
WRITE CYCLE^[9]												
t_{WC}	Write Cycle Time	15		20		20		25		40		ns
t_{SCE}	\overline{CE} LOW to Write End	12		15		20		25		30		ns
t_{AW}	Address Set-Up to Write End	12		15		20		25		30		ns
t_{HA}	Address Hold from Write End	0		0		0		0		0		ns
t_{SA}	Address Set-Up to Write Start	0		0		0		0		0		ns
t_{PWE}	\overline{WE} Pulse Width	12		15		15		20		20		ns
t_{SD}	Data Set-Up to Write End	10		10		10		15		15		ns
t_{HD}	Data Hold from Write End	0		0		0		0		0		ns
t_{LZWE}	\overline{WE} HIGH to Low Z ^[7]	7		7		7		5		5		ns
t_{HZWE}	\overline{WE} LOW to High Z ^[7, 8]	5		5		5		5		10		ns

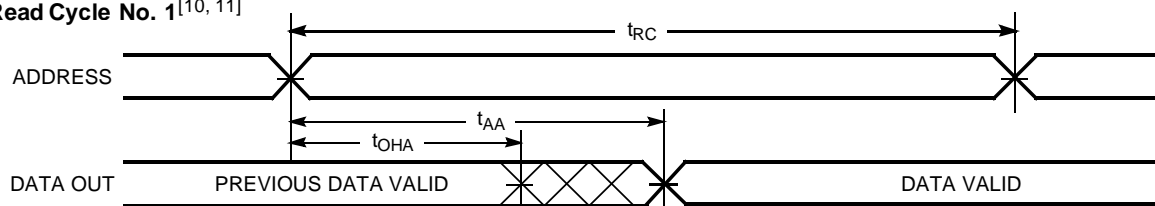
Switching Waveforms
Read Cycle No. 1^[10, 11]

C168A-5

Notes:

6. Test conditions assume signal transition times of 5 ns or less, timing reference levels of 1.5V, input pulse levels of 0 to 3.0V, and output loading of the specified I_{OL}/I_{OH} and 30-pF load capacitance.
7. At any given temperature and voltage condition, t_{HZ} is less than t_{LZ} for all devices. Transition is measured ± 500 mV from steady state voltage with specified loading in part (b) of AC Test Loads and Waveforms.
8. t_{HZCE} and t_{HZWE} are tested with $C_L = 5$ pF as in part (a) of Test Loads and Waveforms. Transition is measured ± 500 mV from steady state voltage.
9. The internal write time of the memory is defined by the overlap of \overline{CE} LOW and \overline{WE} LOW. Both signal must be LOW to initiate a write and either signal can terminate a write by going high. The data input set-up and hold timing should be referenced to the rising edge of the signal that terminates the write.
10. \overline{WE} is HIGH for read cycle.
11. Device is continuously selected, $\overline{CE} = V_{IL}$.

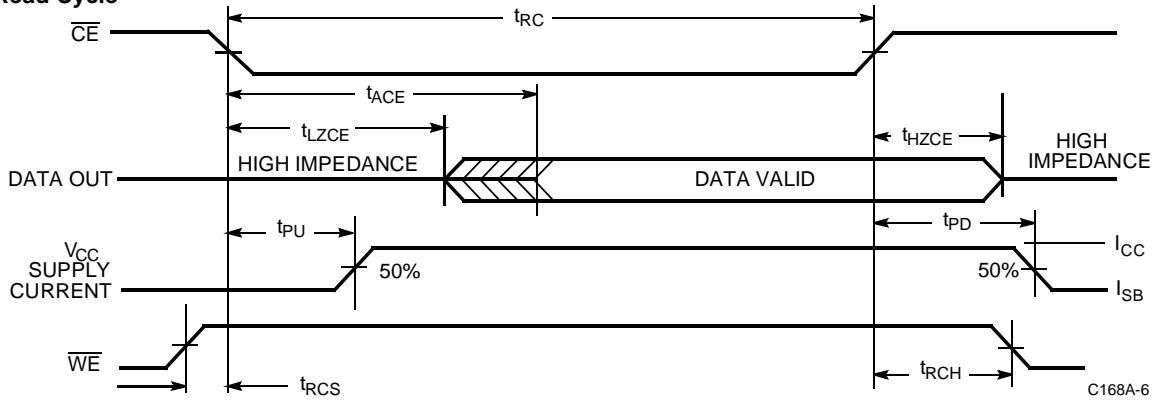
Switching Waveforms (continued)
Read Cycle^[10, 12]

C168A-6

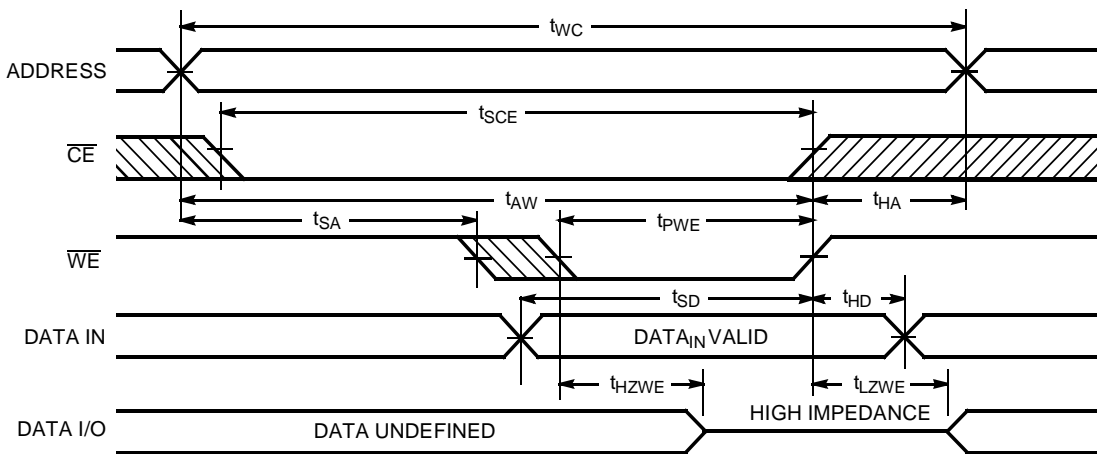
Write Cycle No. 1 (\overline{WE} Controlled)^[9]

C168A-7

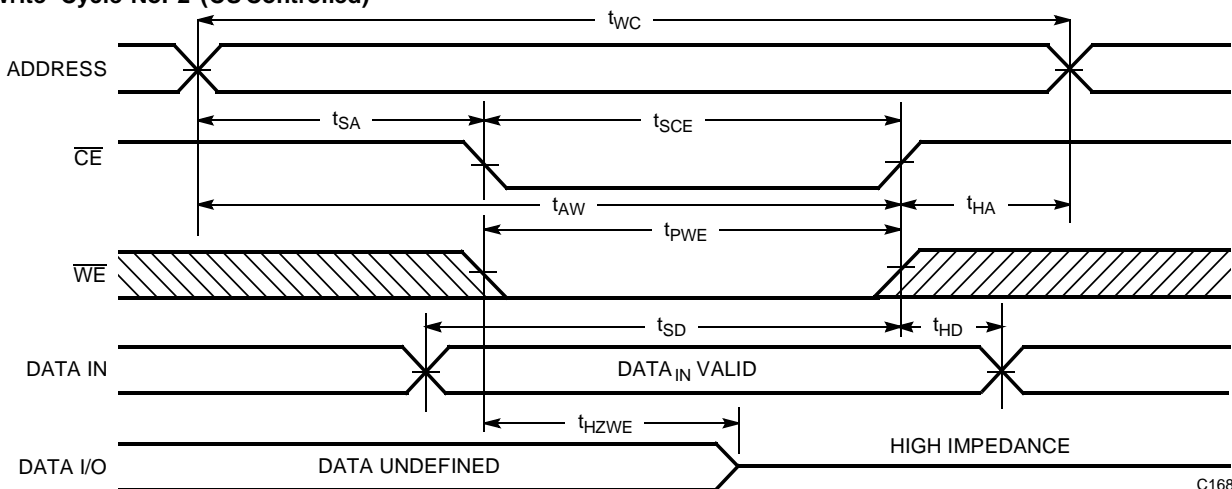
Write Cycle No. 2 (\overline{CS} Controlled)^[9, 13]

C168A-8

Notes:

12. Address valid prior to or coincident with \overline{CE} transition LOW.
13. If \overline{CE} goes HIGH simultaneously with \overline{WE} HIGH, the output remains in a high-impedance state.

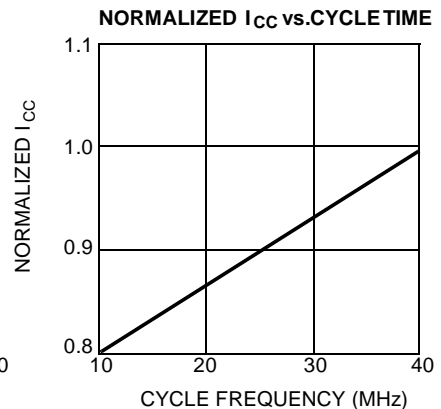
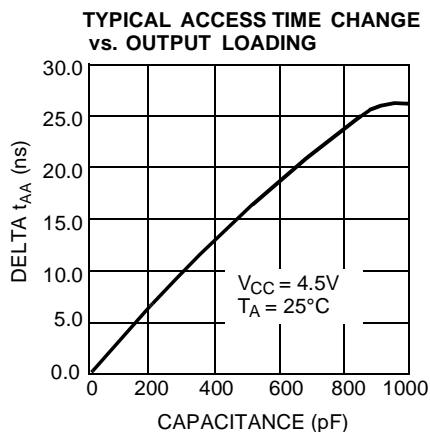
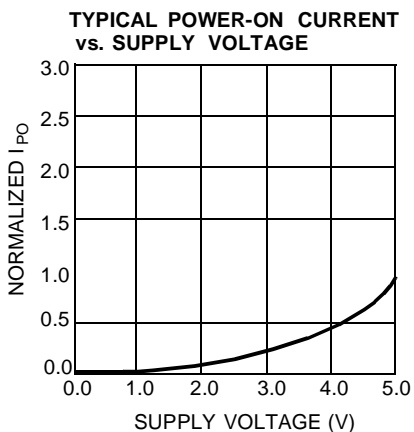
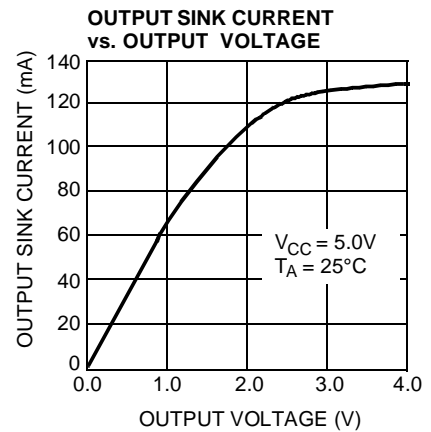
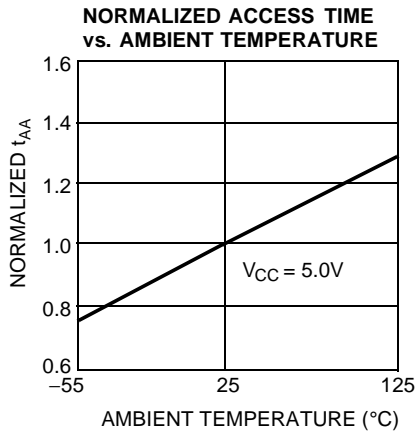
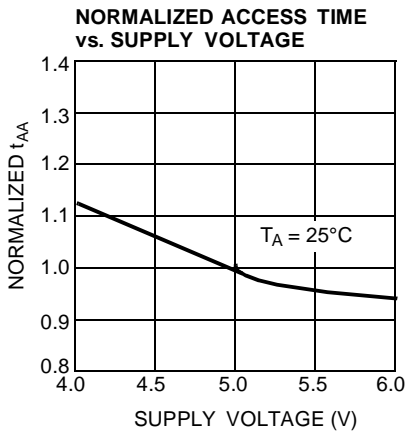
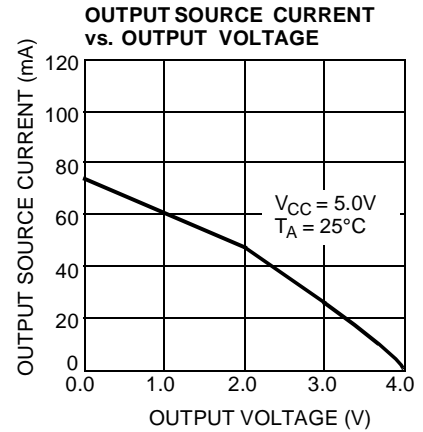
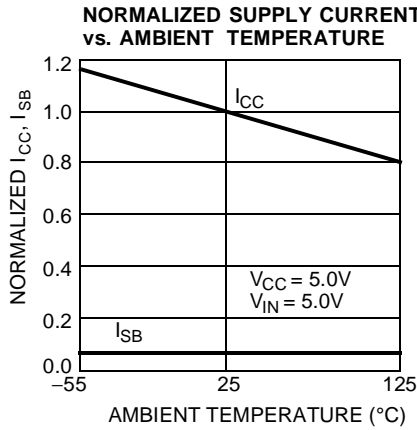
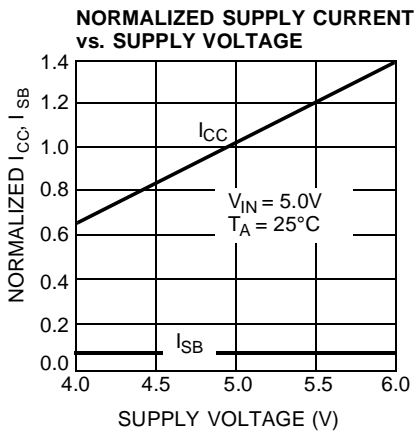
Typical DC and AC Characteristics

Ordering Information

Speed (ns)	I _{CC} (mA)	Ordering Code	Package Name	Package Type	Operating Range
15	115	CY7C168A-15PC	P5	20-Lead (300-Mil) Molded DIP	Commercial
		CY7C168A-15VC	V5	20-Lead Molded SOJ	
20	90	CY7C168A-20PC	P5	20-Lead (300-Mil) Molded DIP	Commercial
		CY7C168A-20VC	V5	20-Lead Molded SOJ	
		CY7C168A-20DMB	D6	20-Lead (300-Mil) CerDIP	Military
25	70	CY7C168A-25PC	P5	20-Lead (300-Mil) Molded DIP	Commercial
		CY7C168A-25VC	V5	20-Lead Molded SOJ	
	80	CY7C168A-25DMB	D6	20-Lead (300-Mil) CerDIP	Military
35	70	CY7C168A-35PC	P5	20-Lead (300-Mil) Molded DIP	Commercial
		CY7C168A-35VC	V5	20-Lead Molded SOJ	
		CY7C168A-35DMB	D6	20-Lead (300-Mil) CerDIP	Military
45	70	CY7C168A-45PC	P5	20-Lead (300-Mil) Molded DIP	Commercial
		CY7C168A-45VC	V5	20-Lead Molded SOJ	
		CY7C168A-45DMB	D6	20-Lead (300-Mil) CerDIP	Military

MILITARY SPECIFICATIONS
Group A Subgroup Testing
DC Characteristics

Parameter	Subgroups
V _{OH}	1, 2, 3
V _{OL}	1, 2, 3
V _{IH}	1, 2, 3
V _{IL Max.}	1, 2, 3
I _{Ix}	1, 2, 3
I _{OZ}	1, 2, 3
I _{CC}	1, 2, 3
I _{SB1}	1, 2, 3
I _{SB2}	1, 2, 3

Document #: 38-00095-E

Switching Characteristics

Parameter	Subgroups
READ CYCLE	
t _{RC}	7, 8, 9, 10, 11
t _{AA}	7, 8, 9, 10, 11
t _{OHA}	7, 8, 9, 10, 11
t _{ACE}	7, 8, 9, 10, 11
t _{RCS}	7, 8, 9, 10, 11
t _{RCH}	7, 8, 9, 10, 11
WRITE CYCLE	
t _{WC}	7, 8, 9, 10, 11
t _{SCE}	7, 8, 9, 10, 11
t _{AW}	7, 8, 9, 10, 11
t _{HA}	7, 8, 9, 10, 11
t _{SA}	7, 8, 9, 10, 11
t _{PWE}	7, 8, 9, 10, 11
t _{SD}	7, 8, 9, 10, 11
t _{HD}	7, 8, 9, 10, 11

Package Diagrams

20-Lead (300-Mil) CerDIP D6
MIL-STD-1835 D-8 Config. A

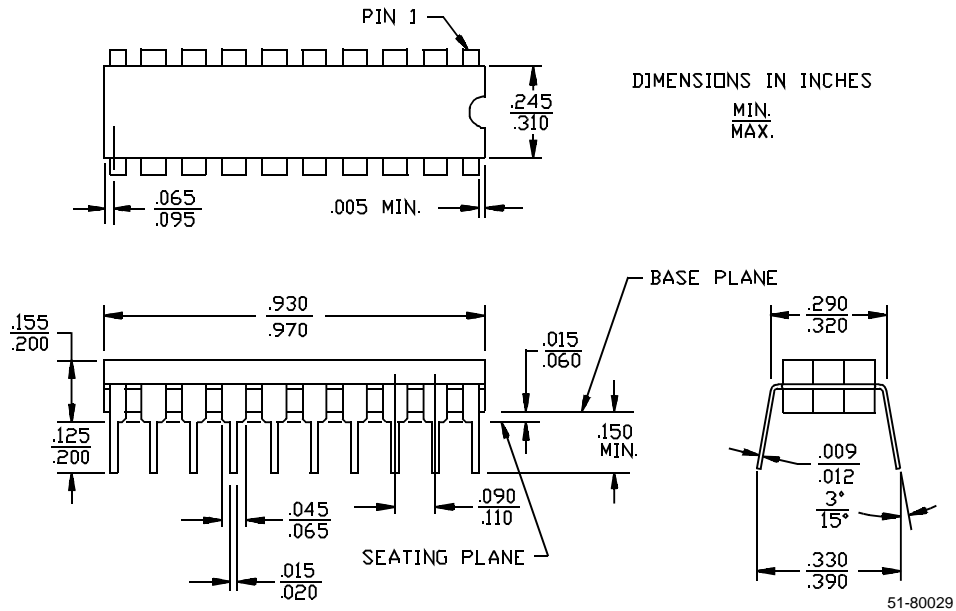

20-Lead (300-Mil) Molded DIP P5

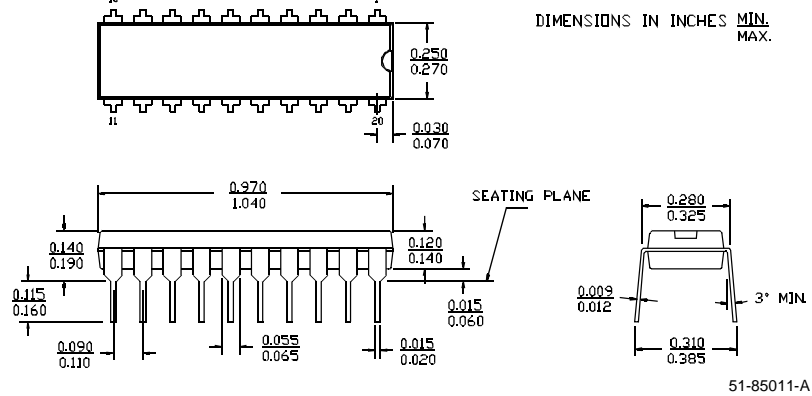

Package Diagrams (continued)

20-Lead (300-Mil) Molded SOJ V5
