

MONOLITHIC 5-TAP FIXED DELAY LINE (SERIES 3D7105)

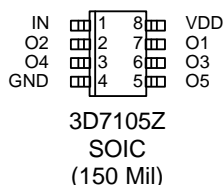

FEATURES

- All-silicon, low-power CMOS technology
- TTL/CMOS compatible inputs and outputs
- Vapor phase, IR and wave solderable
- Auto-insertable (DIP pkg.)
- Low ground bounce noise
- Leading- and trailing-edge accuracy
- Delay range:** .75 through 80ns
- Delay tolerance:** 5% or 1ns
- Temperature stability:** $\pm 3\%$ typical (0C-70C)
- Vdd stability:** $\pm 1\%$ typical (4.75V-5.25V)
- Minimum input pulse width:** 30% of total delay
- 14-pin DIP and 16-pin SOIC available as drop-in replacements for hybrid delay lines



PACKAGES

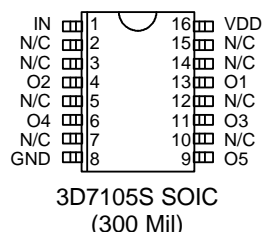
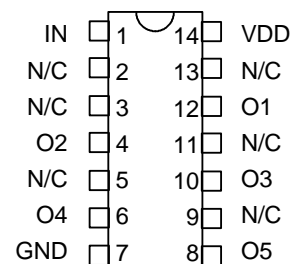
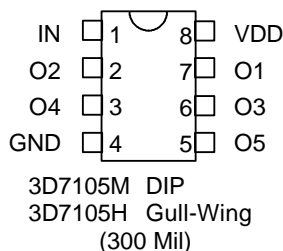

3D7105 DIP
3D7105G Gull-Wing
3D7105K Unused pins removed
(300 Mil)

FUNCTIONAL DESCRIPTION

The 3D7105 5-Tap Delay Line product family consists of fixed-delay CMOS integrated circuits. Each package contains a single delay line, tapped and buffered at 5 points spaced uniformly in time. Tap-to-tap (incremental) delay values can range from 0.75ns through 8.0ns. The input is reproduced at the outputs without inversion, shifted in time as per the user-specified dash number. The 3D7105 is TTL- and CMOS-compatible, capable of driving ten 74LS-type loads, and features both rising- and falling-edge accuracy.

The all-CMOS 3D7105 integrated circuit has been designed as a reliable, economic alternative to hybrid TTL fixed delay lines. It is offered in a standard 8-pin auto-insertable DIP and a space saving surface mount 8-pin SOIC.

PIN DESCRIPTIONS

IN	Delay Line Input
O1	Tap 1 Output (20%)
O2	Tap 2 Output (40%)
O3	Tap 3 Output (60%)
O4	Tap 4 Output (80%)
O5	Tap 5 Output (100%)
VCC	+5 Volts
GND	Ground
N/C	No Connection

TABLE 1: PART NUMBER SPECIFICATIONS

PART NUMBER				TOLERANCES		INPUT RESTRICTIONS			
DIP-8 3D7105M 3D7105H	SOIC-8 3D7105Z	DIP-14 3D7105 3D7105G 3D7105K	SOIC-16 3D7105S	TOTAL DELAY (ns)	TAP-TAP DELAY (ns)	Max Operating Frequency	Absolute Max Oper. Freq.	Min Operating Pulse Width	Absolute Min Oper. P.W.
-.75	-.75	-.75	-.75	$3.0 \pm 1.0^*$	0.75 ± 0.4	41.7 MHz	166.7 MHz	12.0 ns	3.00 ns
-1	-1	-1	-1	$4.0 \pm 1.0^*$	1.0 ± 0.5	37.0 MHz	166.7 MHz	13.5 ns	3.00 ns
-1.5	-1.5	-1.5	-1.5	$6.0 \pm 1.0^*$	1.5 ± 0.7	30.3 MHz	166.7 MHz	16.5 ns	3.00 ns
-2	-2	-2	-2	$8.0 \pm 1.0^*$	2.0 ± 0.8	25.6 MHz	166.7 MHz	19.5 ns	3.00 ns
-2.5	-2.5	-2.5	-2.5	$10.0 \pm 1.0^*$	2.5 ± 1.0	22.2 MHz	133.3 MHz	22.5 ns	3.75 ns
-4	-4	-4	-4	$16.0 \pm 1.0^*$	4.0 ± 1.3	15.9 MHz	83.3 MHz	31.5 ns	6.00 ns
-5	-5	-5	-5	25.0 ± 1.3	5.0 ± 1.5	13.3 MHz	66.7 MHz	37.5 ns	7.50 ns
-8	-8	-8	-8	40.0 ± 2.0	8.0 ± 1.5	9.52 MHz	41.7 MHz	52.5 ns	12.0 ns

* Total delay referenced to Tap1 output; Input-to-Tap1 = $5.0\text{ns} \pm 1.0\text{ns}$

NOTE: Any dash number between .75 and 8 not shown is also available.

©1996 Data Delay Devices

APPLICATION NOTES

OPERATIONAL DESCRIPTION

The 3D7105 five-tap delay line architecture is shown in Figure 1. The delay line is composed of a number of delay cells connected in series. Each delay cell produces at its output a replica of the signal present at its input, shifted in time. The delay cells are matched and share the same compensation signals, which minimizes tap-to-tap delay deviations over temperature and supply voltage variations.

INPUT SIGNAL CHARACTERISTICS

The Frequency and/or Pulse Width (high or low) of operation may adversely impact the specified delay accuracy of the particular device. The reasons for the dependency of the output delay accuracy on the input signal characteristics are varied and complex. Therefore a **Maximum** and an **Absolute Maximum** operating input frequency and a **Minimum** and an **Absolute Minimum** operating pulse width have been specified.

OPERATING FREQUENCY

The **Absolute Maximum Operating Frequency** specification, tabulated in **Table 1**, determines the highest frequency of the delay line input signal that can be reproduced, shifted in time at the device output, with acceptable duty cycle distortion.

The **Maximum Operating Frequency** specification determines the highest frequency of the delay line input signal for which the output delay accuracy is guaranteed.

To guarantee the **Table 1** delay accuracy for input frequencies higher than the **Maximum Operating Frequency**, the 3D7105 must be tested at the user operating frequency. Therefore, to facilitate production and device identification, **the part number will include a custom reference designator** identifying the intended frequency of operation. The programmed delay accuracy of the device is guaranteed, therefore, only at the user specified input frequency. Small input frequency variation about the selected frequency will only marginally impact the programmed delay accuracy, if at all. **Nevertheless, it is strongly recommended that the engineering staff at DATA DELAY DEVICES be consulted.**

OPERATING PULSE WIDTH

The **Absolute Minimum Operating Pulse Width** (high or low) specification, tabulated in **Table 1**, determines the smallest Pulse Width of the delay line input signal that can be reproduced, shifted in time at the device output, with acceptable pulse width distortion.

The **Minimum Operating Pulse Width** (high or low) specification determines the smallest Pulse Width of the delay line input signal for which the output delay accuracy tabulated in **Table 1** is guaranteed.

To guarantee the **Table 1** delay accuracy for input pulse width smaller than the **Minimum Operating Pulse Width**, the 3D7105 must be tested at the user operating pulse width. Therefore, to facilitate production and device identification, **the part number will include a**

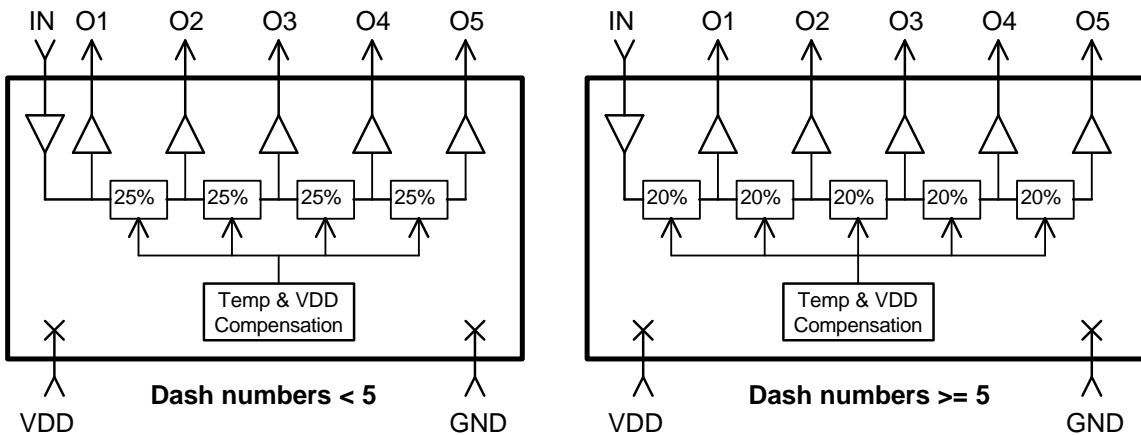

Figure 1: 3D7105 Functional Diagram

APPLICATION NOTES (CONT'D)

custom reference designator identifying the intended frequency and duty cycle of operation. The programmed delay accuracy of the device is guaranteed, therefore, only for the user specified input characteristics. Small input pulse width variation about the selected pulse width will only marginally impact the programmed delay accuracy, if at all. **Nevertheless, it is strongly recommended that the engineering staff at DATA DELAY DEVICES be consulted.**

POWER SUPPLY AND TEMPERATURE CONSIDERATIONS

The delay of CMOS integrated circuits is strongly dependent on power supply and temperature. The monolithic 3D7105 programmable delay line utilizes novel and innovative compensation

circuitry to minimize the delay variations induced by fluctuations in power supply and/or temperature.

The **thermal coefficient** is reduced to **600 PPM/C**, which is equivalent to a variation, over the 0C-70C operating range, of $\pm 3\%$ from the room-temperature delay settings and/or **1.0ns**, whichever is greater. The **power supply coefficient** is reduced, over the 4.75V-5.25V operating range, to $\pm 1\%$ of the delay settings at the nominal 5.0VDC power supply and/or **1.5ns**, whichever is greater. **It is essential that the power supply pin be adequately bypassed and filtered. In addition, the power bus should be of as low an impedance construction as possible. Power planes are preferred.**

DEVICE SPECIFICATIONS

TABLE 2: ABSOLUTE MAXIMUM RATINGS

PARAMETER	SYMBOL	MIN	MAX	UNITS	NOTES
DC Supply Voltage	V_{DD}	-0.3	7.0	V	
Input Pin Voltage	V_{IN}	-0.3	$V_{DD}+0.3$	V	
Input Pin Current	I_{IN}	-1.0	1.0	mA	25C
Storage Temperature	T_{STRG}	-55	150	C	
Lead Temperature	T_{LEAD}		300	C	10 sec

TABLE 3: DC ELECTRICAL CHARACTERISTICS

(0C to 70C, 4.75V to 5.25V)

PARAMETER	SYMBOL	MIN	MAX	UNITS	NOTES
Static Supply Current*	I_{DD}		30	mA	
High Level Input Voltage	V_{IH}	2.0		V	
Low Level Input Voltage	V_{IL}		0.8	V	
High Level Input Current	I_{IH}		1	μA	$V_{IH} = V_{DD}$
Low Level Input Current	I_{IL}		1	μA	$V_{IL} = 0V$
High Level Output Current	I_{OH}	-4.0		mA	$V_{DD} = 4.75V$ $V_{OH} = 2.4V$
Low Level Output Current	I_{OL}	4.0		mA	$V_{DD} = 4.75V$ $V_{OL} = 0.4V$
Output Rise & Fall Time	T_R & T_F		2	ns	$C_{LD} = 5$ pf

* $I_{DD}(\text{Dynamic}) = 5 * C_{LD} * V_{DD} * F$
 where: C_{LD} = Average capacitance load/tap (pf)
 F = Input frequency (GHz)

Input Capacitance = 10 pf typical
 Output Load Capacitance (C_{LD}) = 25 pf max

SILICON DELAY LINE AUTOMATED TESTING

TEST CONDITIONS

INPUT:

Ambient Temperature: $25^{\circ}\text{C} \pm 3^{\circ}\text{C}$
Supply Voltage (Vcc): $5.0\text{V} \pm 0.1\text{V}$
Input Pulse: High = $3.0\text{V} \pm 0.1\text{V}$
 Low = $0.0\text{V} \pm 0.1\text{V}$
Source Impedance: 50Ω Max.
Rise/Fall Time: 3.0 ns Max. (measured between 0.6V and 2.4V)
Pulse Width: $\text{PW}_{\text{IN}} = 1.25 \times \text{Total Delay}$
Period: $\text{PER}_{\text{IN}} = 2.5 \times \text{Total Delay}$

OUTPUT:

R_{load}: $10\text{K}\Omega \pm 10\%$
C_{load}: $5\text{pf} \pm 10\%$
Threshold: 1.5V (Rising & Falling)

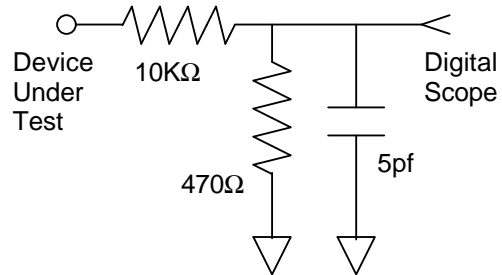

NOTE: The above conditions are for test only and do not in any way restrict the operation of the device.

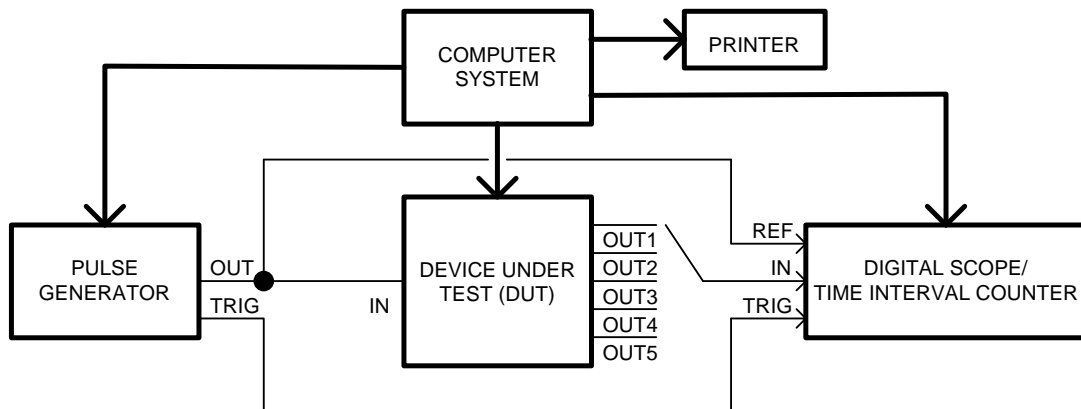

Figure 2: Test Setup

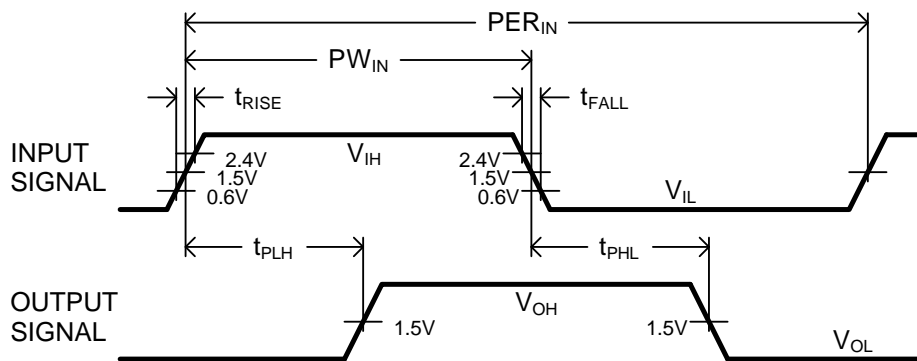

Figure 3: Timing Diagram