

# 5-TAP, HCMOS-INTERFACED FIXED DELAY LINE (SERIES DDU66C)



## FEATURES

- Five equally spaced outputs
- Fits standard 14-pin DIP socket
- Low profile
- Auto-insertable
- Input & outputs fully CMOS interfaced & buffered
- 10 T<sup>2</sup>L fan-out capability

## PACKAGES

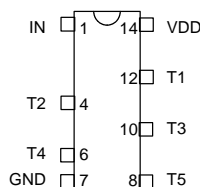

DDU66C-xx DIP  
DDU66C-xxA2 Gull-Wing  
DDU66C-xxB2 J-Lead  
DDU66C-xxME7 Military DIP

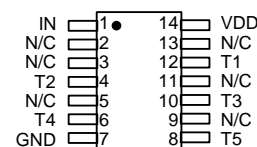

DDU66C-xxD1 Com. SMD  
DDU66C-xxD4 Com. SMD  
DDU66C-xxMD1 Mil. SMD  
DDU66C-xxMD4 Mil. SMD

## FUNCTIONAL DESCRIPTION

The DDU66C-series device is a 5-tap digitally buffered delay line. The signal input (IN) is reproduced at the outputs (T1-T5), shifted in time by an amount given by the device dash number. For dash numbers less than 40, the total delay of the line is measured from T1 to T5, with the nominal value given by the dash number. The nominal tap-to-tap delay increment is given by 1/4 of this number. The inherent delay from IN to T1 is nominally 8.0ns. For dash numbers greater than or equal to 40, the total delay of the line is measured from IN to T5, with the nominal value given by the dash number. The nominal tap-to-tap delay increment is given by 1/5 of this number.

## PIN DESCRIPTIONS

IN Signal Input  
T1-T5 Tap Outputs  
VDD +5 Volts  
GND Ground

## SERIES SPECIFICATIONS

- **Minimum input pulse width:** 40% of total delay
- **Output rise time:** 8ns typical
- **Supply voltage:** 5VDC  $\pm$  5%
- **Supply current:** I<sub>CCL</sub> = 40 $\mu$ a typical  
I<sub>CCH</sub> = 10ma typical
- **Operating temperature:** 0° to 70° C
- **Temp. coefficient of total delay:** 300 PPM/°C

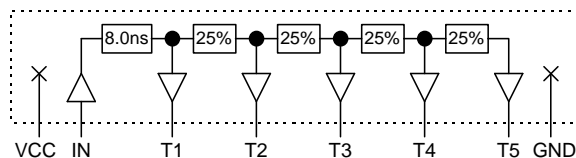

Functional diagram for dash numbers < 40

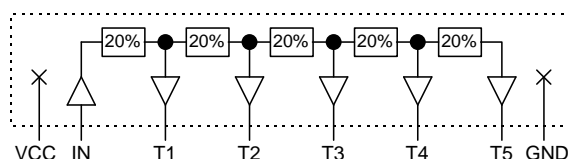

Functional diagram for dash numbers  $\geq$  40

## DASH NUMBER SPECIFICATIONS

Part Number	Total Delay (ns)	Delay Per Tap (ns)
DDU222C-10	10 $\pm$ 2.0 *	2.5 $\pm$ 1.0
DDU222C-20	20 $\pm$ 2.0 *	5.0 $\pm$ 2.0
DDU222C-50	50 $\pm$ 3.0	10.0 $\pm$ 3.0
DDU222C-60	60 $\pm$ 3.0	12.0 $\pm$ 3.0
DDU222C-75	75 $\pm$ 4.0	15.0 $\pm$ 3.0
DDU222C-100	100 $\pm$ 5.0	20.0 $\pm$ 3.0
DDU222C-125	125 $\pm$ 6.5	25.0 $\pm$ 3.0
DDU222C-150	150 $\pm$ 7.5	30.0 $\pm$ 3.0
DDU222C-175	175 $\pm$ 8.0	35.0 $\pm$ 4.0
DDU222C-200	200 $\pm$ 10.0	40.0 $\pm$ 4.0
DDU222C-250	250 $\pm$ 12.5	50.0 $\pm$ 5.0

\* Total delay is referenced to first tap output  
Input to first tap = 8.0ns  $\pm$  2ns

NOTE: Any dash number between 10 and 250 not shown is also available.

©1997 Data Delay Devices

---



---

## APPLICATION NOTES

### HIGH FREQUENCY RESPONSE

The DDU66C tolerances are guaranteed for input pulse widths and periods greater than those specified in the test conditions. Although the device will function properly for pulse widths as small as 40% of the total delay and periods as small as 80% of the total delay (for a symmetric input), the delays may deviate from their values at low frequency. However, for a given input condition, the deviation will be repeatable from pulse to pulse. Contact technical support at Data

Delay Devices if your application requires device testing at a specific input condition.

### POWER SUPPLY BYPASSING

The DDU66C relies on a stable power supply to produce repeatable delays within the stated tolerances. A 0.1uf capacitor from VDD to GND, located as close as possible to the VDD pin, is recommended. A wide VDD trace and a clean ground plane should be used.

---



---

## DEVICE SPECIFICATIONS

### TABLE 1: ABSOLUTE MAXIMUM RATINGS

PARAMETER	SYMBOL	MIN	MAX	UNITS	NOTES
DC Supply Voltage	$V_{DD}$	-0.3	7.0	V	
Input Pin Voltage	$V_{IN}$	-0.3	$V_{DD}+0.3$	V	
Storage Temperature	$T_{STRG}$	-55	150	C	
Lead Temperature	$T_{LEAD}$		300	C	10 sec

### TABLE 2: DC ELECTRICAL CHARACTERISTICS

(0C to 70C, 4.75V to 5.25V)

PARAMETER	SYMBOL	MIN	TYP	MAX	UNITS	NOTES
High Level Output Voltage	$V_{OH}$	3.98	4.4		V	$V_{DD} = 5.0$ , $I_{OH} = MAX$ $V_{IH} = MIN$ , $V_{IL} = MAX$
Low Level Output Voltage	$V_{OL}$		0.15	0.26	V	$V_{DD} = 5.0$ , $I_{OL} = MAX$ $V_{IH} = MIN$ , $V_{IL} = MAX$
High Level Output Current	$I_{OH}$			-4.0	mA	
Low Level Output Current	$I_{OL}$			4.0	mA	
High Level Input Voltage	$V_{IH}$	3.15			V	
Low Level Input Voltage	$V_{IL}$			1.35	V	
Input Current	$I_{IH}$			0.10	$\mu A$	$V_{DD} = 5.0$

**PACKAGE DIMENSIONS**

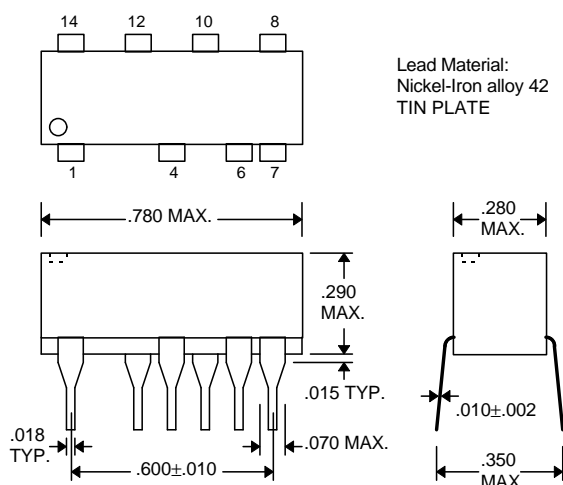

**DDU66C-xx (Commercial)**

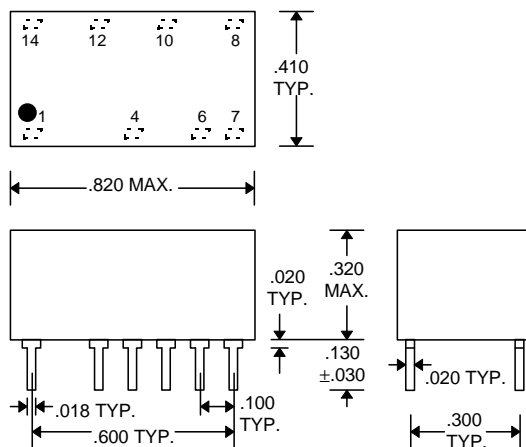

**DDU66C-xxME7 (Military)**

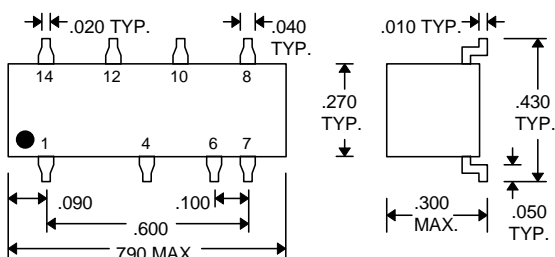

**DDU66C-xxA2 (Commercial Gull-Wing)**

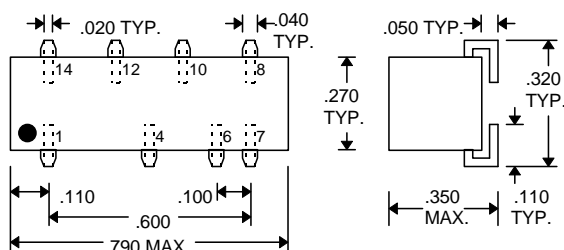

**DDU66C-xxB2 (Commercial J-Lead)**

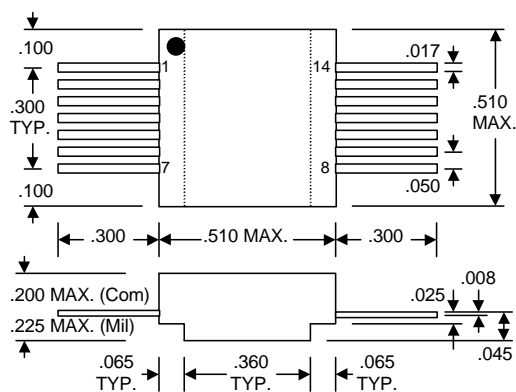

**DDU66C-xxD1 (Commercial SMD)**  
**DDU66C-xxMD1 (Military SMD)**

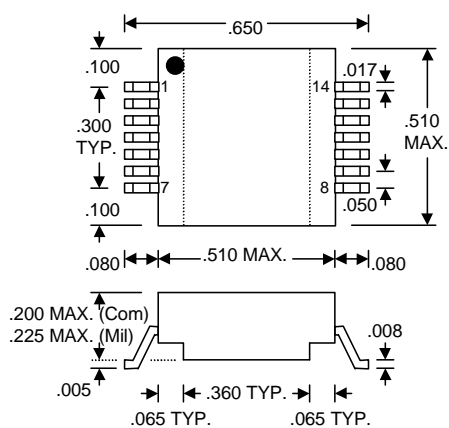

**DDU66C-xxD4 (Commercial SMD)**  
**DDU66C-xxMD4 (Military SMD)**

## DELAY LINE AUTOMATED TESTING

### TEST CONDITIONS

**INPUT:**

**Ambient Temperature:**  $25^{\circ}\text{C} \pm 3^{\circ}\text{C}$   
**Supply Voltage (VDD):**  $5.0\text{V} \pm 0.1\text{V}$   
**Input Pulse:** High =  $5.0\text{V} \pm 0.1\text{V}$   
 Low =  $0.0\text{V} \pm 0.1\text{V}$   
**Source Impedance:**  $50\Omega$  Max.  
**Rise/Fall Time:**  $5.0\text{ ns Max.}$  (measured between  $0.5\text{V}$  and  $4.5\text{V}$ )  
**Pulse Width:**  $PW_{IN} = 1.5 \times \text{Total Delay}$   
**Period:**  $PER_{IN} = 10 \times \text{Total Delay}$

**OUTPUT:**

**Load:** 1 FAST-TTL Gate  
**C<sub>load</sub>:**  $5\text{pf} \pm 10\%$   
**Threshold:**  $2.5\text{V}$  (Rising & Falling)

**NOTE:** The above conditions are for test only and do not in any way restrict the operation of the device.

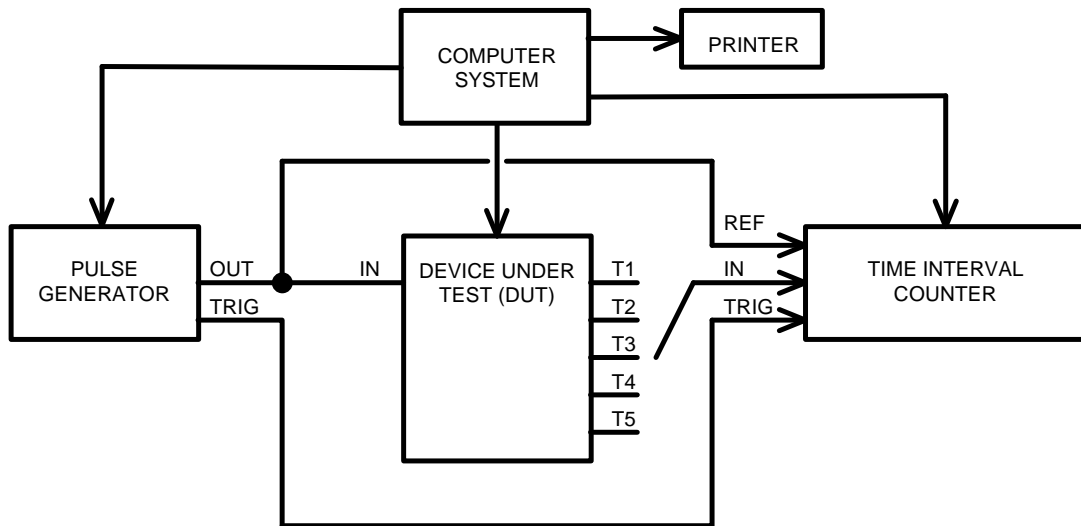

**Test Setup**

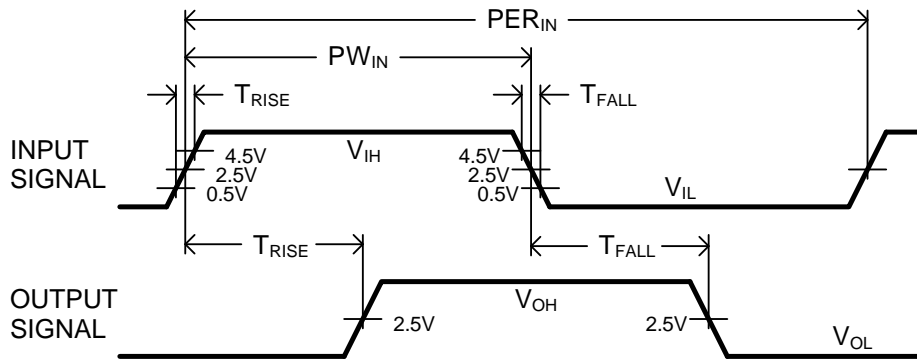

**Timing Diagram For Testing**