

7-BIT PROGRAMMABLE DELAY LINE (SERIES PDU17F)



FEATURES

- Digitally programmable in 128 delay steps
- Monotonic delay-versus-address variation
- Two separate outputs: inverting & non-inverting
- Precise and stable delays
- Input & outputs fully TTL interfaced & buffered
- 10 T²L fan-out capability
- Fits standard 40-pin DIP socket
- Auto-insertable

PACKAGES

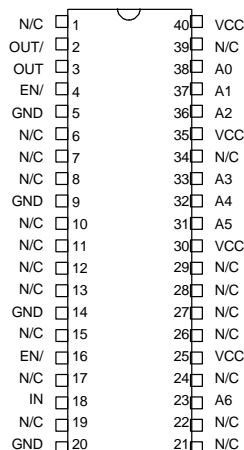

- PDU17F-xx
DIP
- PDU17F-xxC5
Gull-Wing
- PDU17F-xxM
Military DIP
- PDU17F-xxMC5
Military Gull-Wing

FUNCTIONAL DESCRIPTION

The PDU17F-series device is a 7-bit digitally programmable delay line. The delay, TD_A , from the input pin (IN) to the output pins (OUT, OUT/) depends on the address code (A6-A0) according to the following formula:

$$TD_A = TD_0 + T_{INC} * A$$

where A is the address code, T_{INC} is the incremental delay of the device, and TD_0 is the inherent delay of the device. The incremental delay is specified by the dash number of the device and can range from 0.5ns through 10ns, inclusively. The enable pins (EN/) are held LOW during normal operation. These pins must always be in the same state and may be tied together externally. When these signals are brought HIGH, OUT and OUT/ are forced into LOW and HIGH states, respectively. The address is not latched and must remain asserted during normal operation.

PIN DESCRIPTIONS

- IN Delay Line Input
- OUT Non-inverted Output
- OUT/ Inverted Output
- A0-A6 Address Bits
- EN/ Output Enable
- VCC +5 Volts
- GND Ground

SERIES SPECIFICATIONS

- Programmed delay tolerance:** 5% or 2ns, whichever is greater
- Inherent delay (TD_0):** 13ns typical (OUT)
12ns typical (OUT/)
- Setup time and propagation delay:**
Address to input setup (T_{AIS}): 10ns
Disable to output delay (T_{DISO}): 6ns typ. (OUT)
- Operating temperature:** 0° to 70° C
- Temperature coefficient:** 100PPM/°C (excludes TD_0)
- Supply voltage V_{CC} :** 5VDC \pm 5%
- Supply current:** I_{CCH} = 68ma
 I_{CCL} = 86ma
- Minimum pulse width:** 8% of total delay

DASH NUMBER SPECIFICATIONS

Part Number	Incremental Delay Per Step (ns)	Total Delay Change (ns)
PDU17F-.5	.5 \pm .3	63.5 \pm 3.2
PDU17F-1	1 \pm .5	127 \pm 6.4
PDU17F-2	2 \pm .5	254 \pm 12.7
PDU17F-3	3 \pm 1.0	381 \pm 19.1
PDU17F-4	4 \pm 1.0	508 \pm 25.4
PDU17F-5	5 \pm 1.5	635 \pm 31.8
PDU17F-6	6 \pm 1.5	762 \pm 38.1
PDU17F-8	8 \pm 2.0	1,016 \pm 50.8
PDU17F-10	10 \pm 2.0	1,270 \pm 63.5

NOTE: Any dash number between .5 and 10 not shown is also available.

APPLICATION NOTES

ADDRESS UPDATE

The PDU17F is a memory device. As such, special precautions must be taken when changing the delay address in order to prevent spurious output signals. The timing restrictions are shown in Figure 1.

After the last signal edge to be delayed has appeared on the OUT pin, a minimum time, T_{OAX} , is required before the address lines can change. This time is given by the following relation:

$$T_{OAX} = \max \{ (A_i - A_{i-1}) * T_{INC}, 0 \}$$

where A_{i-1} and A_i are the old and new address codes, respectively. Violation of this constraint may, depending on the history of the input signal, cause spurious signals to appear on the OUT pin. The possibility of spurious signals persists until the required T_{OAX} has elapsed.

A similar situation occurs when using the EN/ signal to disable the output while IN is active. In this case, the unit must be held in the disabled state until the device is able to "clear" itself. This is achieved by holding the EN/ signal high and the IN signal low for a time given by:

$$T_{DISH} = A_i * T_{INC}$$

Violation of this constraint may, depending on the history of the input signal, cause spurious signals to appear on the OUT pin. The

possibility of spurious signals persists until the required T_{DISH} has elapsed.

INPUT RESTRICTIONS

There are three types of restrictions on input pulse width and period listed in the **AC Characteristics** table. The **recommended** conditions are those for which the delay tolerance specifications and monotonicity are guaranteed. The **suggested** conditions are those for which signals will propagate through the unit without significant distortion. The **absolute** conditions are those for which the unit will produce some type of output for a given input.

When operating the unit between the recommended and absolute conditions, the delays may deviate from their values at low frequency. However, these deviations will remain constant from pulse to pulse if the input pulse width and period remain fixed. In other words, the delay of the unit exhibits frequency and pulse width dependence when operated beyond the recommended conditions. Please consult the technical staff at Data Delay Devices if your application has specific high-frequency requirements.

Please note that the increment tolerances listed represent a design goal. Although most delay increments will fall within tolerance, they are not guaranteed throughout the address range of the unit. Monotonicity is, however, guaranteed over all addresses.

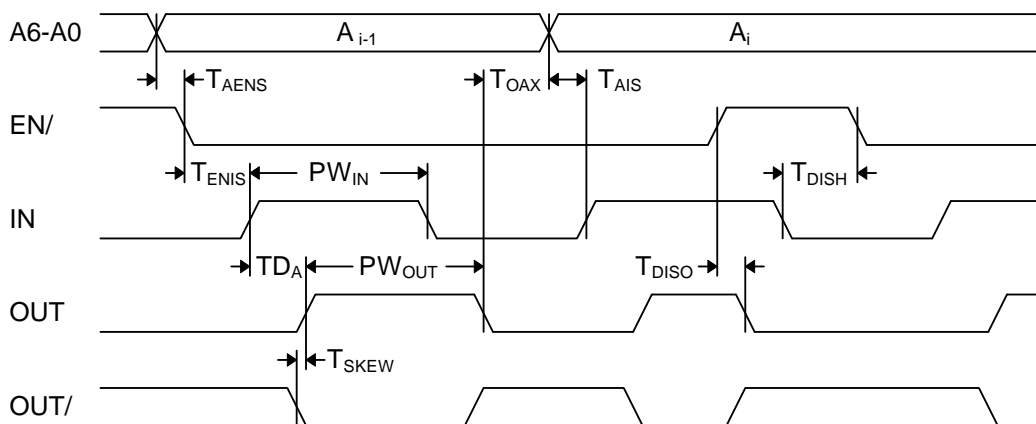

Figure 1: Timing Diagram

DEVICE SPECIFICATIONS
TABLE 1: AC CHARACTERISTICS

PARAMETER	SYMBOL	MIN	TYP	UNITS
Total Programmable Delay	TD_T		127	T_{INC}
Inherent Delay	TD_0		13.0	ns
Output Skew	T_{SKEW}		1.5	ns
Disable to Output Low Delay	T_{DISO}		6.0	ns
Address to Enable Setup Time	T_{AENS}	2.0		ns
Address to Input Setup Time	T_{AIS}	10.0		ns
Enable to Input Setup Time	T_{ENIS}	8.0		ns
Output to Address Change	T_{OAX}	See Text		
Disable Hold Time	T_{DISH}	See Text		
Input Period	Absolute	PER_{IN}	16	% of TD_T
	Suggested	PER_{IN}	32	% of TD_T
	Recommended	PER_{IN}	200	% of TD_T
Input Pulse Width	Absolute	PW_{IN}	8	% of TD_T
	Suggested	PW_{IN}	16	% of TD_T
	Recommended	PW_{IN}	100	% of TD_T

TABLE 2: ABSOLUTE MAXIMUM RATINGS

PARAMETER	SYMBOL	MIN	MAX	UNITS	NOTES
DC Supply Voltage	V_{CC}	-0.3	7.0	V	
Input Pin Voltage	V_{IN}	-0.3	$V_{DD}+0.3$	V	
Storage Temperature	T_{STRG}	-55	150	C	
Lead Temperature	T_{LEAD}		300	C	10 sec

TABLE 3: DC ELECTRICAL CHARACTERISTICS

(0C to 70C, 4.75V to 5.25V)

PARAMETER	SYMBOL	MIN	TYP	MAX	UNITS	NOTES
High Level Output Voltage	V_{OH}	2.5	3.4		V	$V_{CC} = \text{MIN}, I_{OH} = \text{MAX}$ $V_{IH} = \text{MIN}, V_{IL} = \text{MAX}$
Low Level Output Voltage	V_{OL}		0.35	0.5	V	$V_{CC} = \text{MIN}, I_{OL} = \text{MAX}$ $V_{IH} = \text{MIN}, V_{IL} = \text{MAX}$
High Level Output Current	I_{OH}			-1.0	mA	
Low Level Output Current	I_{OL}			20.0	mA	
High Level Input Voltage	V_{IH}	2.0			V	
Low Level Input Voltage	V_{IL}			0.8	V	
Input Clamp Voltage	V_{IK}			-1.2	V	$V_{CC} = \text{MIN}, I_I = I_{IK}$
Input Current at Maximum Input Voltage	I_{IHH}			0.1	mA	$V_{CC} = \text{MAX}, V_I = 7.0V$
High Level Input Current	I_{IH}			20	μA	$V_{CC} = \text{MAX}, V_I = 2.7V$
Low Level Input Current	I_{IL}			-0.6	mA	$V_{CC} = \text{MAX}, V_I = 0.5V$
Short-circuit Output Current	I_{OS}	-60		-150	mA	$V_{CC} = \text{MAX}$
Output High Fan-out				25	Unit	
Output Low Fan-out				12.5	Load	

PACKAGE DIMENSIONS

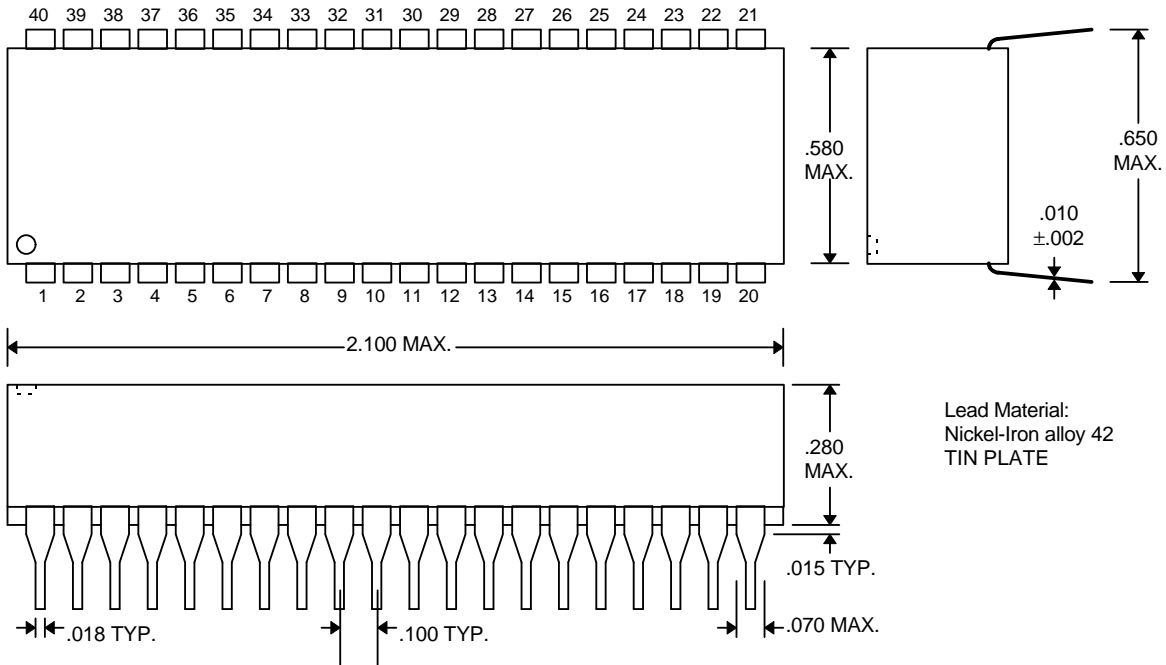

DIP (PDU17F-xx, PDU17F-xxM)

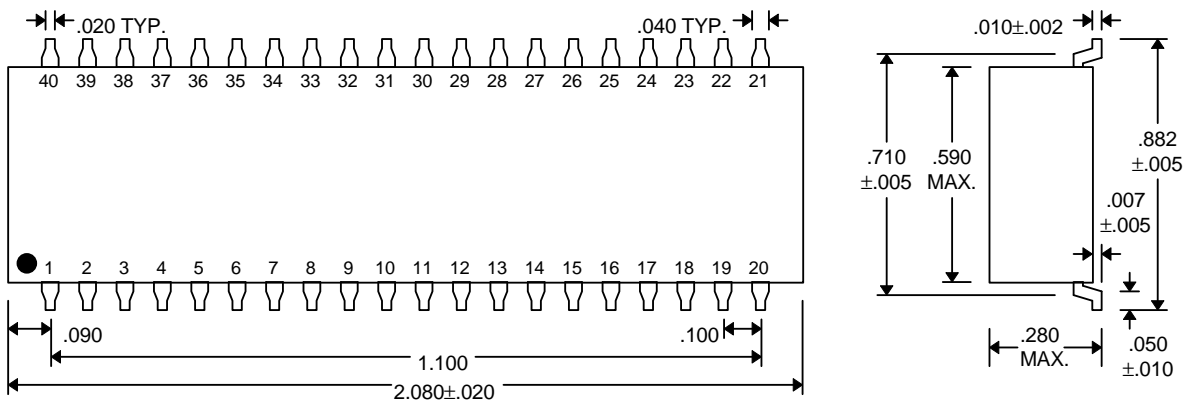

Gull-Wing (PDU17F-xxC5, PDU17F-xxMC5)

DELAY LINE AUTOMATED TESTING

TEST CONDITIONS

INPUT:

Ambient Temperature: $25^{\circ}\text{C} \pm 3^{\circ}\text{C}$

Supply Voltage (V_{CC}): $5.0\text{V} \pm 0.1\text{V}$

Input Pulse: High = $3.0\text{V} \pm 0.1\text{V}$
Low = $0.0\text{V} \pm 0.1\text{V}$

Source Impedance: 50Ω Max.

Rise/Fall Time: 3.0 ns Max. (measured between 0.6V and 2.4V)

Pulse Width: $PW_{IN} = 1.5 \times \text{Total Delay}$

Period: $PER_{IN} = 4.5 \times \text{Total Delay}$

OUTPUT:

Load: 1 FAST-TTL Gate

C_{load} : $5\text{pf} \pm 10\%$

Threshold: 1.5V (Rising & Falling)

NOTE: The above conditions are for test only and do not in any way restrict the operation of the device.

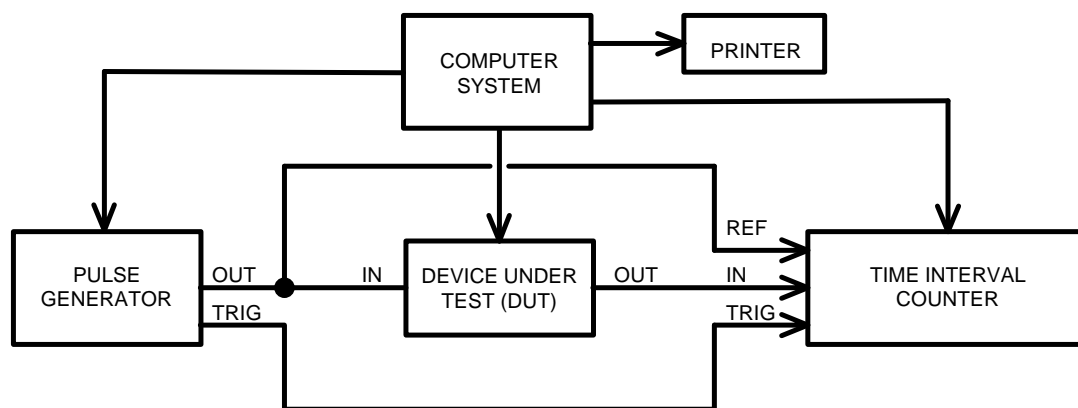

Test Setup

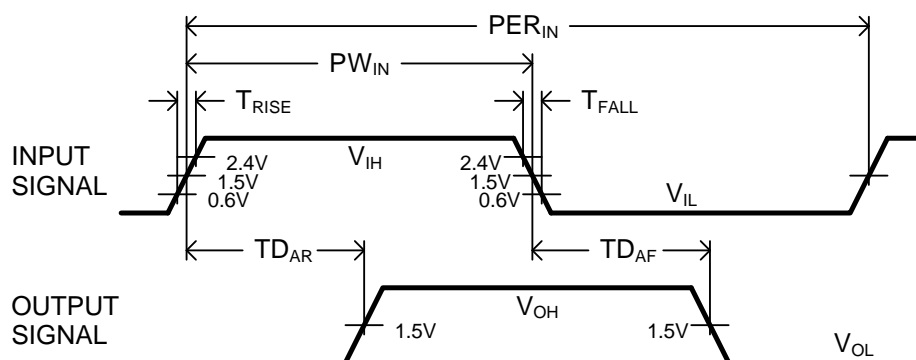

Timing Diagram For Testing