

DBL 1016

5 Dots LED LEVEL METER

DBL 1016 series are a monolithic integrated circuit designed for 5 dot LED level meter driver.

FEATURES

- Capable of generating a bar-display or input voltage with 5 LEDs.
- Power supply voltage range is wide(3.5 to 16V) for a wide range of applications.
- Operates with either AC or DC input voltage using a built-in rectifier amplifier.
- LEDs are driven by a constant current; stable under varying power supply voltages.
- Lighting levels remain stable under varying power supply voltages using a built-in reference voltage.

APPLICATIONS

- AC level meters such as VU meters.
- DC level meters such as signal meters.

MAXIMUM RATINGS [DBL 1016, 1116, 1216, 1316] at Ta=25°C.

Characteristic	Symbol	Rating	Unit
Supply Voltage	V_{CC}	18	V
Power Dissipation	P_D	1,100	mW
Operating Temperature	T_{opr}	-25 ~ +60	°C
Storage Temperature	T_{stg}	-55 ~ +125	°C

EQUIVALENT CIRCUIT

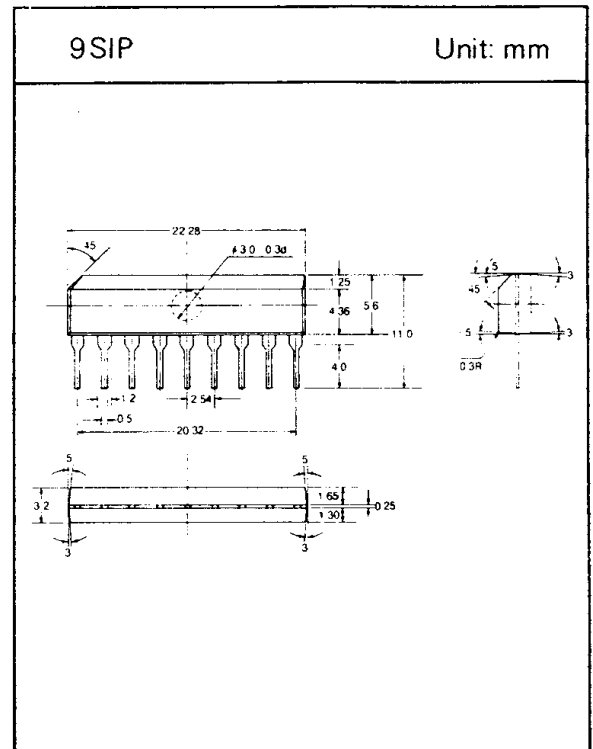
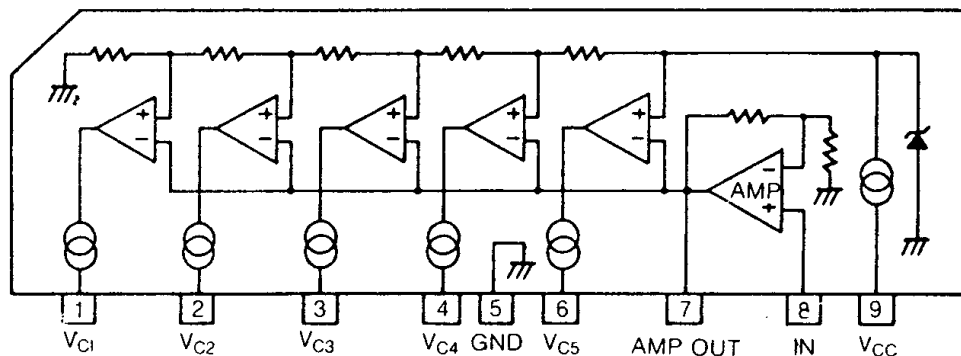

DBL 1016

□ ELECTRICAL CHARACTERISTICS

(Unless otherwise specified, $T_a = 25^\circ\text{C}$, $V_{CC} = 6\text{V}$, $f = 1\text{KHz}$)

[DBL 1016]

Characteristic	Symbol	Test Condition	Min.	Typ.	Max.	Unit
Supply Current	I_{CCQ}	—	—	5	8	mA
Sensitivity	V_{IN}	V_{C3} on-level	74	85	96	mVrms
Comparator Level 1	V_{c1}	—	-11.5	-10	-8.5	dB
Comparator Level 2	V_{c2}	—	-6	-5	-4	dB
Comparator Level 3	V_{c3}	Point of adjustment	—	0	—	dB
Comparator Level 4	V_{c4}	—	2.5	3	3.5	dB
Comparator Level 5	V_{c5}	—	5	6	7	dB
LED Constant Current	I_{LED}	—	11	15	18.5	mA
Input Bias Current	I_{IB}	—	-1.0	-0.3	—	μA

[DBL 1116]

Characteristic	Symbol	Test Condition	Min.	Typ.	Max.	Unit
Supply Current	I_{CCQ}	—	—	5	8	mA
Sensitivity	V_{IN}	V_{C3} on-level	91	105	119	mVrms
Comparator Level 1	V_{c1}	—	$0.28V_{C3}$	$0.33V_{C3}$	$0.40V_{C3}$	mVrms
Comparator Level 2	V_{c2}	—	$0.59V_{C3}$	$0.67V_{C3}$	$0.75V_{C3}$	mVrms
Comparator Level 3	V_{c3}	Point of adjustment	—	V_{IN}	—	mVrms
Comparator Level 4	V_{c4}	—	$1.25V_{C3}$	$1.33V_{C3}$	$1.42V_{C3}$	mVrms
Comparator Level 5	V_{c5}	—	$1.48V_{C3}$	$1.67V_{C3}$	$1.85V_{C3}$	mVrms
LED Constant Current	I_{LED}	—	11	15	18.5	mA
Input Bias Current	I_{IB}	—	-1	-0.3	—	μA

[DBL 1216]

Characteristic	Symbol	Test Condition	Min.	Typ.	Max.	Unit
Supply Current	I_{CCQ}	—	—	5	8	mA
Sensitivity	V_{IN}	V_{C3} on-level	74	85	96	mVrms
Comparator Level 1	V_{c1}	—	-11.5	-10	-8.5	dB
Comparator Level 2	V_{c2}	—	-6	-5	-4	dB
Comparator Level 3	V_{c3}	Point of adjustment	—	0	—	dB
Comparator Level 4	V_{c4}	—	2.5	3	3.5	dB
Comparator Level 5	V_{c5}	—	5	6	7	dB
LED Constant Current	I_{LED}	—	—	7	9.5	mA
Input Bias Current	I_{IB}	—	-1	-0.3	—	μA

DBL 1016

□ ELECTRICAL CHARACTERISTICS (Continued)

[DBL 1316]

Characteristic	Symbol	Test Condition	Min.	Typ.	Max.	Unit
Supply Current	I_{CC0}	—	—	5	8	mA
Sensitivity	V_{IN}	V_{C3} on-level	91	105	119	mVrms
Comparator Level 1	V_{C1}	—	$0.28V_{C3}$	$0.33V_{C3}$	$0.40V_{C3}$	mVrms
Comparator Level 2	V_{C2}	—	$0.59V_{C3}$	$0.67V_{C3}$	$0.75V_{C3}$	mVrms
Comparator Level 3	V_{C3}	Point of adjustment	—	V_{IN}	—	mVrms
Comparator Level 4	V_{C4}	—	$1.25V_{C3}$	$1.33V_{C3}$	$1.42V_{C3}$	mVrms
Comparator Level 5	V_{C5}	—	$1.48V_{C3}$	$1.67V_{C3}$	$1.87V_{C3}$	mVrms
LED Constant Current	I_{LED}	—	5	7	9.5	mA
Input Bias Current	I_{IB}	—	-1.0	-0.3	—	μA

□ ALLOWABLE OPERATING CONDITION($T_a=25^\circ C$)

Characteristic	Symbol	Min.	Typ.	Max.	Unit
Supply Voltage	V_{CC}	3.5	6	16	V

□ APPLICATION CIRCUIT(AC-input VU-meter)

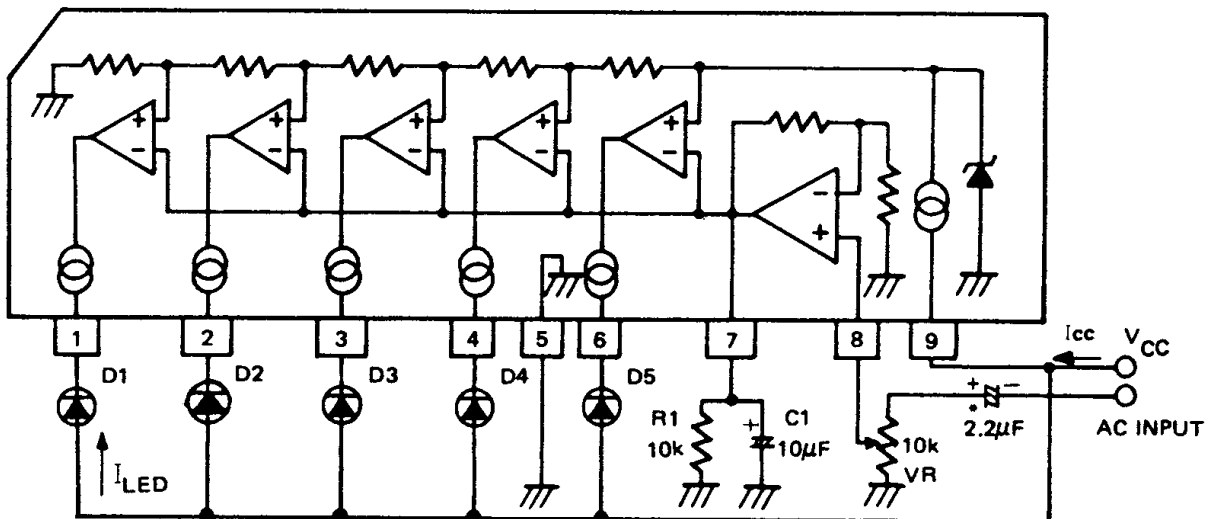

*Capacitor to be omitted when used as a DC-input signal meter.