

DBL 5015

COMPANDOR

The DBL5015 is an noise reduction IC for cordless phone. It is a compandor IC that consist of a compressor and an expander. Compandor reduces transmission noise by compressing and transmitting outgoing signals and expanding received signals. The ICs are designed for minimum requirement of external components and for low voltage operation. Small size is an advantage when used in equipment in which space is a premium. For DATA, input and output terminals are provided for convenience. Two styles of packaging, DIP and SOP, are available to meet different requirements.

FEATURES

- Low voltage operation $V_{opr.} = 2.4 \sim 7.0V$
- Low current consumption $I_{cc} = 4mA (V_{cc} = 3V)$
- Microphone amplifier used in compressor
- Has data input output terminals
- Has a buffer amplifier for filter
- Mute can be set up independently
- Through Functions
- Built in limiter (for compressor)

MAXIMUM RATINGS ($T_a = 25^\circ C$)

Characteristic	Symbol	Rating	Unit
Maximum Supply Voltage	V_{cc}	10	V
Power Dissipations	P_D	1000(D) note 1	mW
		410(S) note2	
Operating Temperature Range	T_{opr}	$-20 \sim 70$	$^\circ C$
Storage Temperature Range	T_{stg}	$-55 \sim 150$	$^\circ C$

- * note 1. Above $T_a = +25^\circ C$, derate at 8mW/
 2. Above $T_a = +25^\circ C$, derate at 3.3mW/

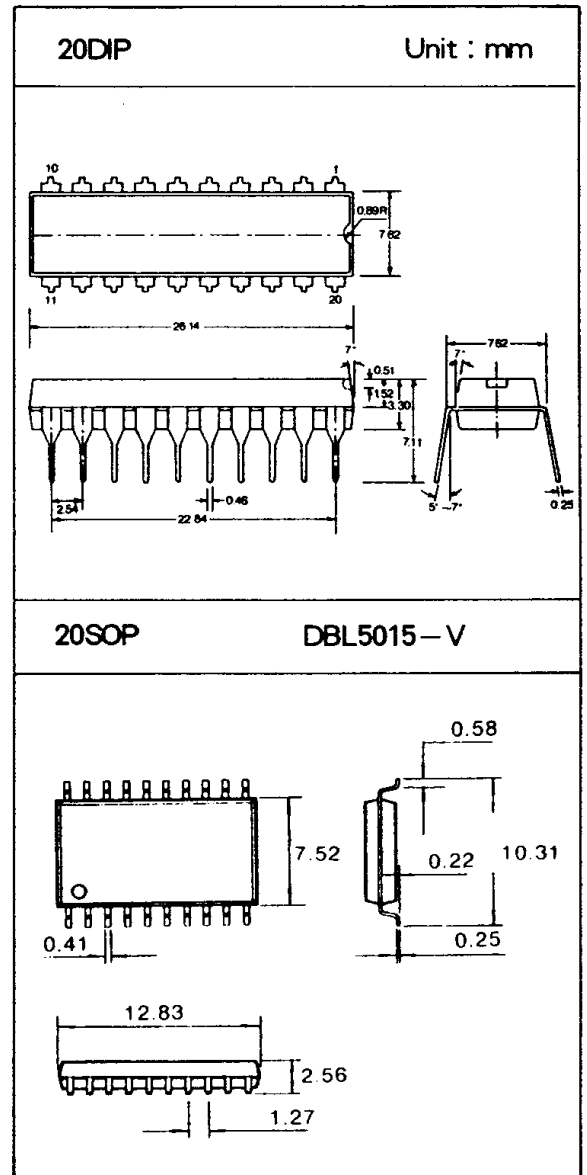

DBL 5015

□ BLOCK DIAGRAM AND TEST CIRCUIT

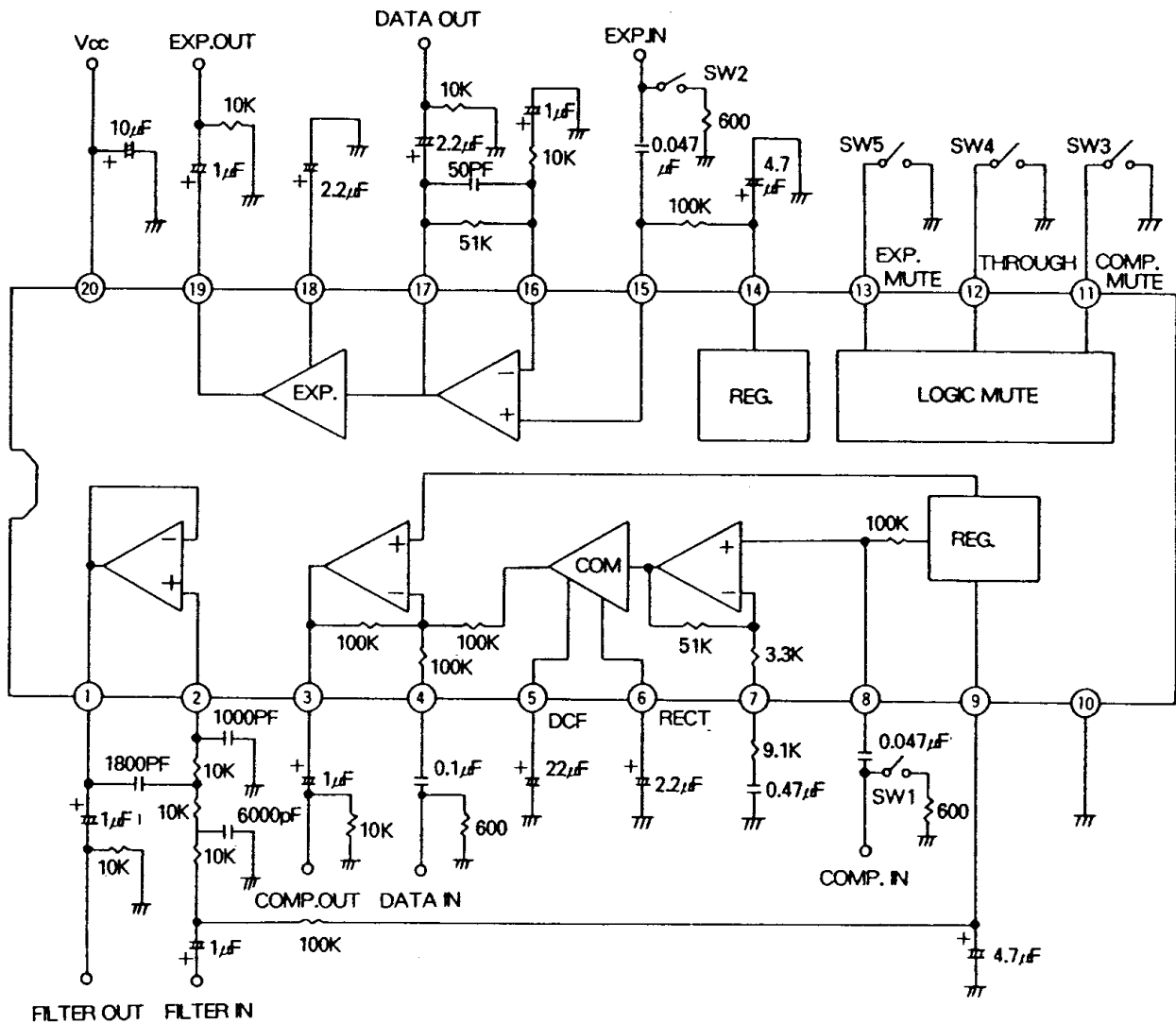

□ SWITCH POSITION

Switch terminal	High (Open or Vcc)	Low (GND)
PIN 11 (SW 3)	Comp Mute OFF	Comp Mute ON
PIN 12 (SW 4)	Compandor	Through
PIN 13 (SW 5)	Exp Mute OFF	Exp Mute ON
PIN 8 (SW 1)	Signal Input - OFF	
PIN 15 (SW 2)	Signal Input - OFF	

□ ELECTRICAL CHARACTERISTICS

(Unless otherwise specified, Ta=25°C, Vcc=3V, f=kHz, RL=10KΩ)

Characteristics	Symbol	Test Condition	Min.	Typ.	Max.	Unit
Squelch Current	Icc _Q	No Signal	—	4.0	6.5	mA
Reference Voltage	Vref	—	1.4	1.5	1.55	V
COMPRESSOR						
Input Resistance	R _{IN}	—	90	120	—	<Ω
Standard Input level	V _{IN}	V _{OUT} =300mVrms=0dB	8.0	12.5	17.0	mV _{rms}
Gain error (1)	ΔGv (1)	v _{IN} = -20dB	-0.5	0	-0.5	dB
Gain error (2)	ΔGv (2)	V _{IN} = -40dB	-0.1	0	-1.0	dB
Through ON/OFF Diff.	ΔGv	v _{IN} =0dB, 12pin GND	-1.5	0	-1.5	dB
Distortion	THD	V _{IN} =620Ω	—	0.5	1.0	%
Noise output	V _{NO}	Rg=620Ω	—	3.0	5.5	mV _{rms}
Muting attenuation	MATT	V _{IN} =0dB, 11pin GND	60	80	—	V _{o-p}
Limiting voltage	V _{LT}	—	1.15	1.35	1.50	
EXPANDER						
Standard Input level	V _{OUT}	V _{IN} =300mVrms=0dB	110	130	160	mV _{rms}
Gain error (1)	ΔGv (1)	v _{IN} = -10dB	-0.5	0	+0.5	dB
Gain error (2)	ΔGv (2)	v _{IN} = -20dB	-1.0	0	-1.0	dB
Gain error (3)	ΔGv (3)	V _{IN} = -30dB	-1.5	0	-1.5	dB
Through ON/OFF Diff.	ΔGv	v _{IN} =0dB, 12pin GND	-2.5	-1.0	-0.5	dB
Distortion	THD	V _{IN} =0dB	—	0.5	1.5	%
Noise output	V _{NO}	Rg=620Ω	—	10	30	μV _{rms}
Muting attenuation	MATT	V _{IN} =0dB, 13pin	60	80	—	dB
Max. output voltage	V _{OUT MAX}	THD 10% level	700	800	—	mV _{rms}
Buffer Amp(LPF)						
Voltage Gain	Gv	V _{IN} =300mVrms	-0.5	0	0.5	dB
Freq. Charact (1)	Δ ₁	V _{IN} =300mVrms, f=3KHz	-4.5	-3	0	dB
Freq. Charact (2)	Δ ₂	V _{IN} =300mVrms, f=30KHz	-75	-60	-55	dB
Distortion	THD	V _{IN} =300mVrms	—	0.02	0.1	%

DBL 5015

ELECTRICAL CHARACTERISTICS

(PIN VOLTAGE AT VCC=3V AND NO INPUT SIGNAL)

PIN NO.	NAME	TYPE.VAL	UNIT	PIN NO.	NAME	TYPE.VAL	UNIT
1	FILTER OUT	1.5	V	11	COMP MUTE	1.3	V
2	FILTER IN	1.5	V	12	THROUGH	1.3	V
3	COMP OUT	1.5	V	13	EXP MUTE	1.3	V
4	DATA IN	1.5	V	14	EXP REF	1.5	V
5	C--DCF	1.5	V	15	EXP IN	1.5	V
6	COMP RECT	0.6	V	16	EXP NF	1.5	V
7	COMP NF	1.5	V	17	DATA OUT	1.5	V
8	COMP IN	1.5	V	18	EXP RECT	0.6	V
9	COMP REF	1.5	V	19	EXP OUT	1.5	V
10	GND	GND	V	20	VCC	VCC	V

TYPICAL PERFORMANCE CHARACTERISTICS

- Input Voltage VS Output Voltage

