

# DMD 5601

## 15CH SELECTOR. FOR CORDLESSPHONE

The DMD5601 channel selector is a CMOS integrated circuit designed specifically to select 15 channels used in 46/49MHz cordless phones. This device has programmable counter, reference frequency generator, ROM for the transmit and receive loop, and phase detector

### FEATURES

- 15channel selection with 4-Bit data input
- On-chip oscillator with external crystal (10.24MHz)
- Lock detect signal
- Standby Operation for power savings
- Operating Voltage range : 2.5V~5.5V
- Maximum operating frequency : 60MHz,  
 $V_{in}=200mV_{p-p}$

### MAXIMUM RATINGS (Ta=25°C)

Characteristic	Symbol	Rating	Unit
Supply Voltage	$V_{DD}$	-0.5~6.0	V
Input Voltage ( All Inputs)	$V_N$	-0.3~ $V_{DD}+0.5$	V
Output Current (LDN)	$I_{out}$	0~3.0	mA
Power Dissipation ( $V_{DD} = 5V$ )	$P_D$	27	mW
Operating Temperature	$T_{op}$	-30~+75	°C
Storage Temperature	$T_{sto}$	-65+150	°C

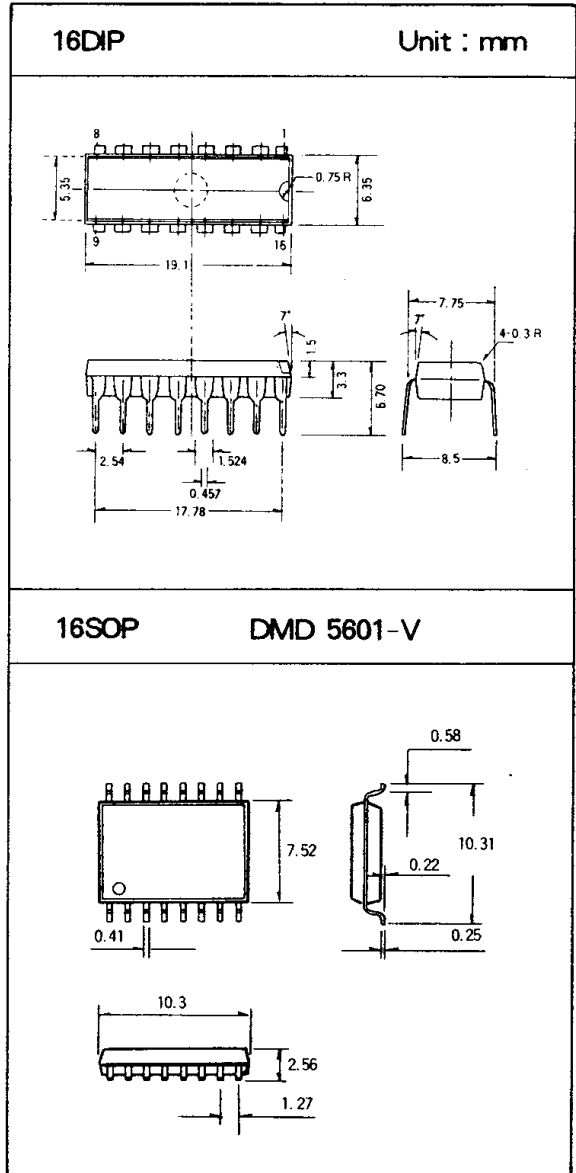

# DMD 5601

## □ BLOCK DIAGRAM

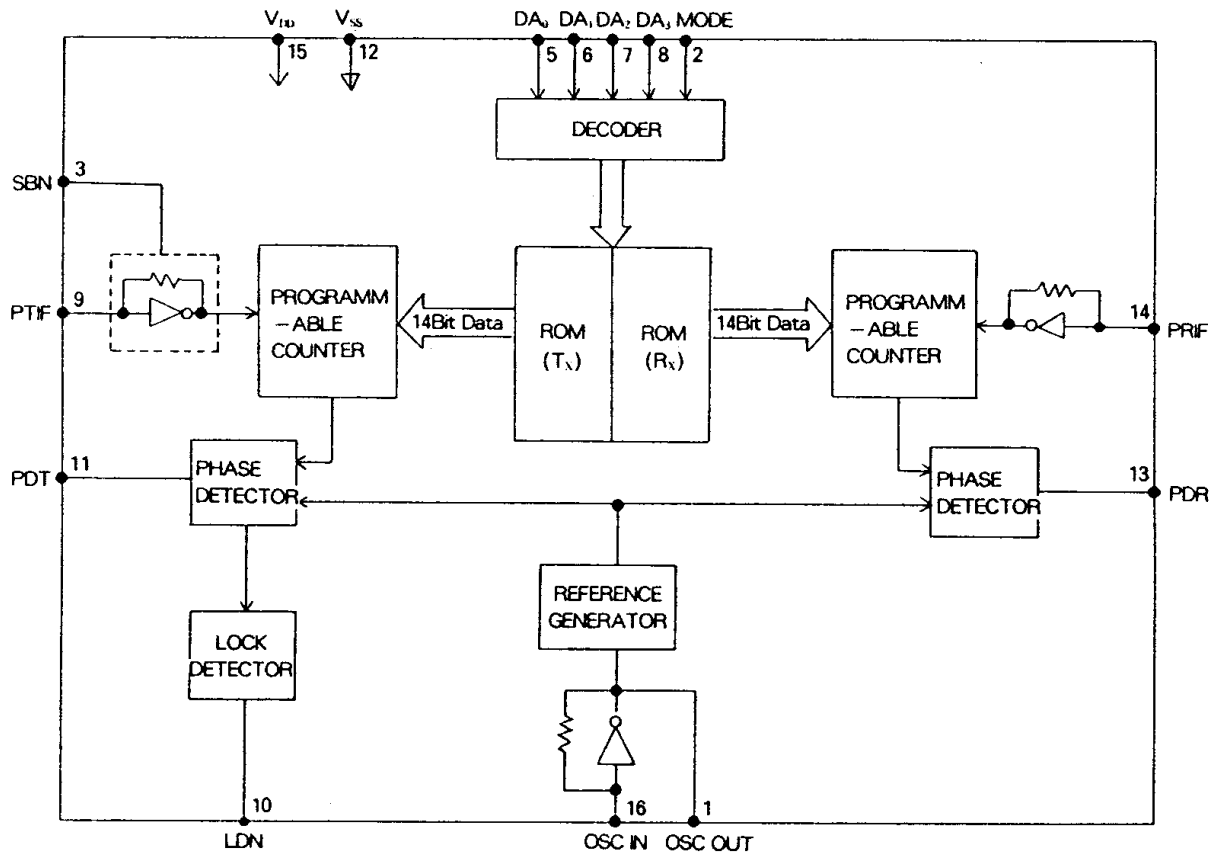

## □ PIN CONFIGURATION

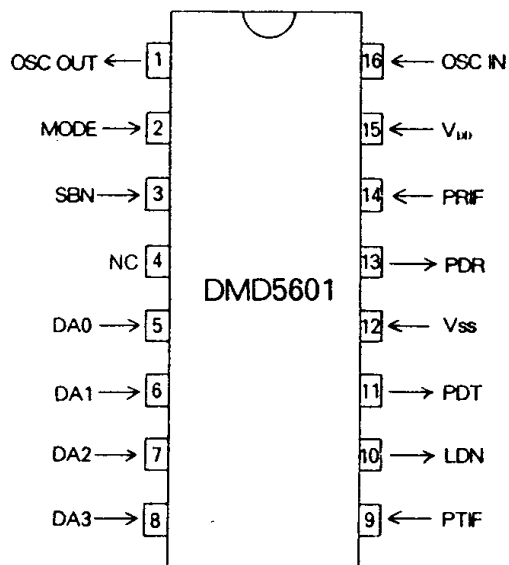

# DMD 5601

## □ PIN DESCRIPTION

PIN		I/O	DESCRIPTION
NAME	NO		
OSC IN	16	I	These pins form reference oscillator when connected to an external parallelresonant crystal (10.2MHz)
OSC OUT	1	O	
MODE	2	1	This pin is for selection handset/base mode. When mode is high, the device is base mode. When mode is low, the device handset mode. This input is normally pull-downed.
SBN	3	1	This pin is used to save power consumption when not transmitting. When SBN is high, both the transmit and receive loops are in operation. When SBN is low, but the transmit loop is disabled. This input is normally pull-downed.
NC	4	—	No connection
DA0	5	I	These pins are used to select one of 15 channels. The frequency assignments are shown in Table 1 and 2. These pins are normally pull-downed.
DA1	6		
DA2	7		
DA3	8		
PTIF	9	I	This is input to programmable counter for transmit loop. This signal is typically derived from the loop VCO and AC coupled. For large signal, it needs DC coupling. The minimum input voltage is $200mV_{p-p}$ .
LDN	10	O	This pin is used to indicate an unlock condition. It is a p-Channel open drain output.
PDT	11	O	This is 3-state output of the transmit phase detector for use as loop error signals.
V <sub>ss</sub>	12	power	Ground for all internal circuits.
PDR	13	O	This is 3-state output of the receive phase detector for use as loop error signals.
PRIF	14	I	This is input to programmable counter for receive loop. This signal is typically derived from the loop VCO and AC coupled. For large signal, it needs DC coupling. The minimum input voltage is $200mV_{p-p}$ .
V <sub>DD</sub>	15	power	Positive supply voltage.

# DMD 5601

## □ ELECTRICAL CHARACTERISTICS

Characteristic	Symbol	Test Condition	VDD (V)	Guaranteed Limit		Unit		
				Min.	Max.			
Power Supply Range	$V_{DD}$	—	—	2.5	5.5	V		
Output Voltage	$V_{OL}$	$I_{xx}=0$ $V_{IN}=V_{DD}$ or 0	Low	2.5	—	0.05	V	
				5.5	—	0.05		
	$V_{OH}$		High	2.5	2.45	—		
				5.5	5.45	—		
Input Voltage	$V_{IL}$	$V_{xx}=0.5V$ or $V_{DD}-0.5V$	Low	2.5	—	0.75	V	
				5.5	—	1.65		
	$V_{IH}$		High	2.5	1.75	—		
				5.5	3.85	—		
Output Current	$I_{OL}$	$V_{ox}=2.2V$ $V_{xx}=5.0V$	Source	2.5	-0.18	—	mA	
				5.5	-0.55	—		
	$I_{OH}$	$V_{ox}=0.3V$ $V_{xx}=0.5V$	Sink	2.5	0.18	—		
				5.5	0.55	—		
Input Current	$I_{IL}$	$V_{IN}=0$	OSC <sub>N</sub> PTIF PRIF	2.5	—	-30	$\mu A$	
				5.5	—	-66		
				2.5	—	-0.05		
				5.5	—	-0.11		
	$I_{IH}$	$V_{IN}=V_{DD}-0.5$	OSC <sub>N</sub> PTIF PRIF	2.5	—	30		
				5.5	—	66		
				2.5	—	50		
				5.5	—	121		
Standby Current	$I_{DD}$	SBN = Vss or open		2.5	—	1.4	mA	
				5.0	—	3.1		
Operating Current	$I_{DD}$	200mV <sub>p-p</sub> Input at PTIF, PRIF, SBN = V <sub>DD</sub>		2.5	—	2.8	mA	
				5.0	—	5.4		
Input Frequency	$F_{IN1}$	Input = 200mV <sub>p-p</sub>	PRIF	3.0	—	60	MHZ	
	$F_{IN2}$					PTIF		60
	$F_{OSC}$					osc in		12

# DMD 5601

BASESET FREQUENCIES (Mode=High)

CH	CHANNEL DATA				RECEIVE			TRANSMIT		
	DA3	DA2	DA1	DA0	F <sub>RX</sub>	F <sub>IN1</sub>	N*	F <sub>TX</sub>	F <sub>IN2</sub>	N*
1	0	0	0	1	49.670	38.975	7795	46.610	46.610	9322
2	0	0	1	0	49.845	39.150	7830	46.630	46.630	9326
3	0	0	1	1	49.860	39.165	7833	46.670	46.670	9334
4	0	1	0	0	49.770	39.075	7815	46.710	46.710	9342
5	0	1	0	1	49.875	39.180	7836	46.730	46.730	9346
6	0	1	1	0	49.830	39.135	7827	46.770	46.770	9354
7	0	1	1	1	49.890	39.195	7839	46.830	46.830	9366
8	1	0	0	0	49.930	39.235	7847	46.870	46.870	9374
9	1	0	0	1	49.990	39.295	7859	46.930	46.930	9386
10	1	0	1	0	49.970	39.275	7855	46.970	46.970	9394
11	1	0	1	1	49.695	39.000	7800	46.510	46.510	9302
12	1	1	0	0	49.710	39.015	7803	46.530	46.530	9306
13	1	1	0	1	49.725	39.030	7806	46.550	46.550	9310
14	1	1	1	0	49.740	39.045	7809	46.570	46.570	9314
15	1	1	1	1	49.755	39.060	7812	46.590	46.590	9318

Notes :  $N^* = F_{IN} / F_{REF}$

Where  $\left\{ \begin{array}{l} F_{IN} \text{ is the VCO frequency} \\ F_{REF} \text{ is the reference frequency (5KHz)} \end{array} \right.$

# DMD 5601

HANDSET FREQUENCIES (Mode=Low)

CH	CHANNEL DATA				RECEIVE			TRANSMIT		
	DA3	DA2	DA1	DA0	F <sub>RX</sub>	F <sub>IN1</sub>	N*	F <sub>TX</sub>	F <sub>IN2</sub>	N*
1	0	0	0	1	46.610	35.915	7183	49.670	49.670	9934
2	0	0	1	0	46.630	35.935	7187	49.845	49.845	9969
3	0	0	1	1	46.670	35.975	7195	49.860	49.860	9972
4	0	1	0	0	46.710	36.015	7203	49.770	49.770	9954
5	0	1	0	1	46.730	36.035	7207	49.875	49.875	9975
6	0	1	1	0	46.770	36.075	7215	49.830	49.830	9966
7	0	1	1	1	46.830	36.135	7227	49.890	49.890	9978
8	1	0	0	0	46.870	36.175	7235	49.930	49.930	9986
9	1	0	0	1	46.930	36.235	7247	49.990	49.990	9998
10	1	0	1	0	46.970	36.275	7255	49.970	49.970	9994
11	1	0	1	1	46.510	35.815	7163	49.695	49.695	9939
12	1	1	0	0	46.530	35.835	7167	49.710	49.710	9942
13	1	1	0	1	46.550	35.855	7171	49.725	49.725	9945
14	1	1	1	0	46.570	35.875	7175	49.740	49.740	9948
15	1	1	1	1	46.590	35.895	7179	49.755	49.755	9951

Notes :  $N^* = F_{IN}/F_{REF}$

Where  $\left\{ \begin{array}{l} F_{IN} \text{ is the VCO frequency} \\ F_{REF} \text{ is the reference frequency (5KHz)} \end{array} \right.$

# DMD 5601

## TEST AND APPLICATION CIRCUIT

