

DMD 5603

10CH SELECTOR FOR CORDLESSPHONE

The DMD 5603 channel selector is a CMOS integrated circuit designed specifically to select 10 channels used in 45/48MHz cordless phones. This device has programmable counter, reference frequency generator, ROM for the transmit and receive loop, and phase detector

□ FEATURES

- 10channel selection with 4-Bit data input
- On-chip oscillator with external crystal(10.24MHz)
- Lock detect signal
- Standby Operation for power savings
- Operating Voltage range : 2.5V~5.5V
- Maximum operating frequency : 60MHz,
 $V_{in}=200mV_{p-p}$

□ MAXIMUM RATINGS($T_a=25^{\circ}C$)

CHARACTERSTIC	SYMBOL	RATING	UNIT
Supply Voltage	V_{DD}	-0.5~6.0	V
Input Voltage(All Inputs)	V_{IN}	$0.3 \sim V_{DD} + 0.5$	V
Output Current(LDN)	I_{out}	0~3.0	mA
Power Dissipation($V_{DD}=5V$)	P_D	27	mw
Operating Temperature	T_{opt}	-30~+75	$^{\circ}C$
Storage Temperature	T_{stg}	-65~+150	$^{\circ}C$

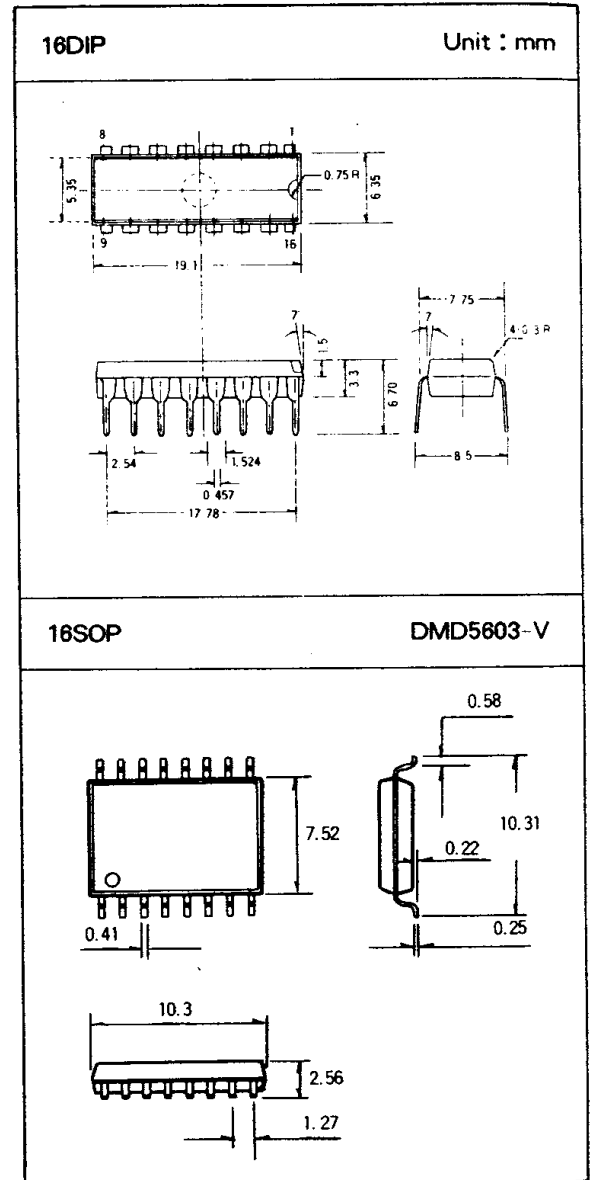

DMD 5603

□ BLOCK DIAGRAM

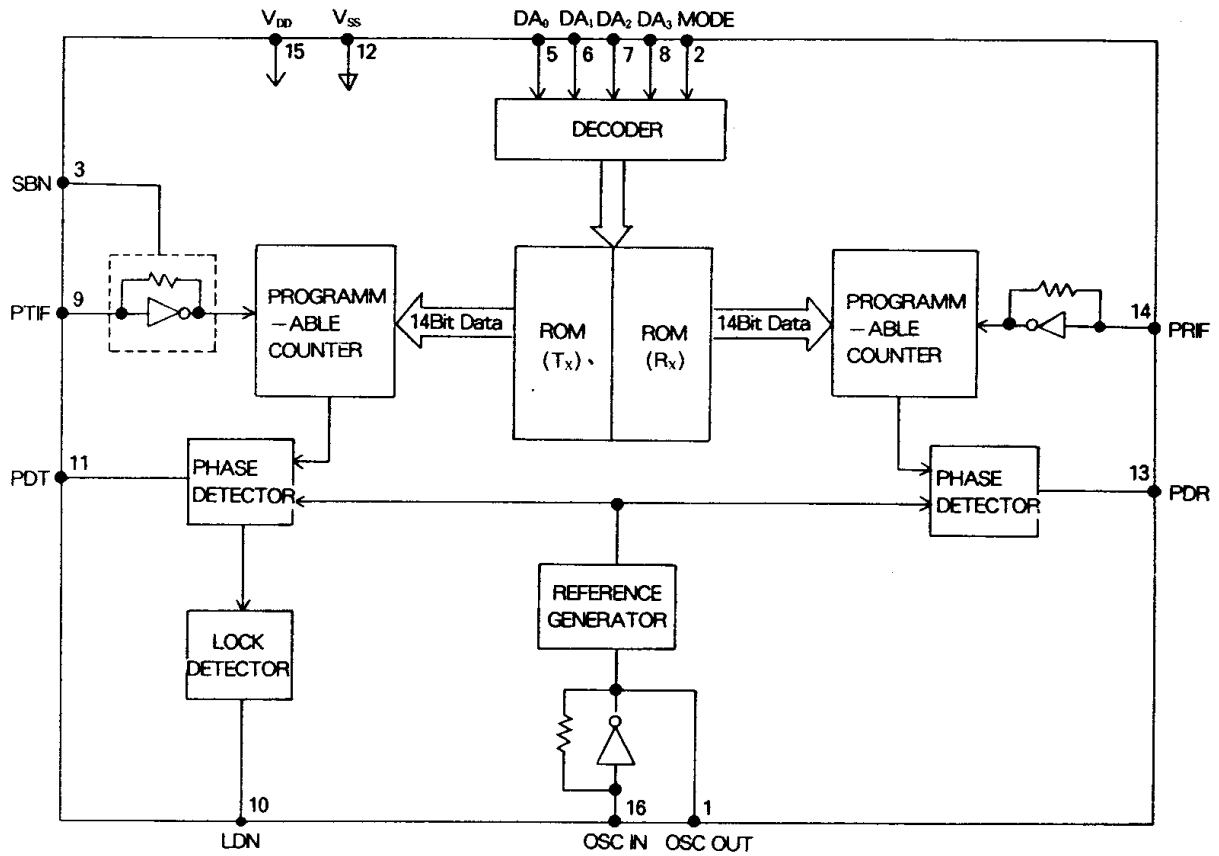

□ PIN CONFIGURATION

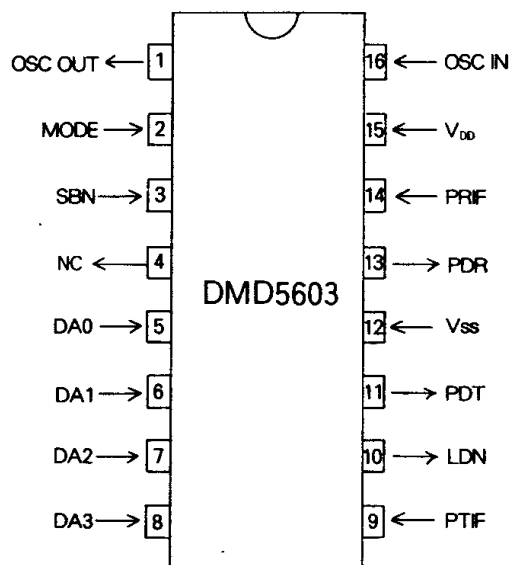

DMD 5603

□ PIN DESCRIPTION

PIN		I/O	DESCRIPTION
NAME	NO		
OSC IN	16	I	These pins form a reference when connected to an external parallel resonant crystal(10.24MHz)
OSC OUT	1	O	
MODE	2	I	The pin is for selecting handset/base mode. When mode is high, the device is base mode. When mode is low, the device handset mode. This input is normally pull-downed.
SBN	3	I	This pin is used to save consumption when not transmitting. When SBN is high, both the transmit and receive loops are in operation. When SBN is low, but the transmit loop is disabled. This input is normally pull-downed.
NC	4	—	No Connection
DA0	5	I	These pins are used to select one of 10 channels. The frequency assignments are shown in Table 1 and 2. These pins are normally pull-downed.
DA1	6		
DA2	7		
DA3	8		
PTIF	9	I	This input to programmable counter for transmit loop. The signal is typically derived from the loop VCO and AC coupled. For large signal, it needs DC coupling. The minimum input voltage is 200mV _{p-p} .
LDN	10	O	This pin is used to indicate an unlock condition. It is a p-channel open-drain output.
PTD	11	O	This is 3-state output of the transmit phase detector for use as loop error signals.
V _{SS}	12	power	Ground for all internal circuits.
PDR	13	O	This is 3-state output of the receive phase detector for use as loop error signals.
PRIF	14	I	This is input to programmable counter for receive loop. This signal is typically derived from the loop VCO and AC coupled. For large signal, it needs DC coupling. The minimum input voltage is 200mV _{p-p} .
V _{DD}	15	power	Positive supply voltage

DMD 5603

ELECTRICAL CHARACTERISTICS

CHARACTERISTIC	SYMBOL	TEST CONDITION		VDD (V)	GUARANTEED LIMIT		UNIT		
					MIN.	MAX.			
Power Supply Range	V_{DD}	-		-	2.5	5.5	V		
Output Voltage	V_{OL}	$I_{out}=0$ $V_{IN}=V_{DD}$ or 0	Low	2.5	-	0.05	V		
				5.5	-	0.05			
	High		2.5	2.45	-				
			5.5	5.45	-				
Input Voltage	V_{IL}	$V_{out}=0.5V$ or $V_{DD}=0.5V$	Low	2.5	-	0.75	V		
				5.5	-	1.65			
	High		2.5	1.76	-				
			5.5	3.86	-				
Output Current	I_{OL}	$V_{out}=2.2V$ $V_{out}=5.0V$	Source	2.5	-0.18	-	mA		
				5.5	-0.55	-			
	Sink		2.5	0.18	-				
			5.5	0.55	-				
Input Current	I_{IL}	$V_{IN}=0$	OSC _{IN} PTIF PRIF	2.5	-	-30	μA		
				5.5	-	-66			
				Data SBN Mode	2.5	-		-0.05	
				5.5	-	-0.11			
	I_{IH}		$V_{IN}=V_{DD}-0.5$	OSC _{IN} PTIF PRIF	2.5	-		30	
					5.5	-		66	
					Data SBN Mode	2.5		-	50
					5.5	-		121	
Standby Current	I_{DD}	SBN=V _{SS} or open		2.5	-	1.4	mA		
				5.5	-	3.6			
Operating Current	I_{DD}	200mV _{P-P} Input at PTIF, PRIF, SBN=V _{DD}		2.5	-	2.8	mA		
				5.5	-	6.2			
Input Frequency	F_{IN1}	Input = 200mV _{P-P}	PRIF	3.0	-	60	MHZ		
	F_{IN2}				PTIF	-		60	
	F_{OSC}				osc in	-		12	

DMD 5603

BASESET FORQUENCIES(Mode= High)

CH	CHANNEL DATA				RECEIVE			TRANSMIT		
	DA3	DA2	DA1	DA0	F _{RX}	F _{INI}	N*	F _{RX}	F _{INI}	N*
1	0	0	0	1	48.250	37.555	7500	45.250	45.250	9050
2	0	0	1	0	48.275	37.580	7516	45.275	45.275	9055
3	0	0	1	1	48.300	37.605	7521	45.300	45.300	9060
4	0	1	0	0	48.325	37.630	7526	45.325	45.325	9065
5	0	1	0	1	48.350	37.655	7531	45.350	45.350	9070
6	0	1	1	0	48.375	37.680	7536	45.375	45.375	9075
7	0	1	1	1	48.400	37.705	7541	45.400	45.400	9080
8	1	0	0	0	48.425	37.730	7546	45.425	45.425	9085
9	1	0	0	1	48.450	37.755	7551	45.450	45.450	9090
10	1	0	1	0	48.475	37.780	7556	45.475	45.475	9095

Notes : 1. $N^* = F_{IN}/F_{REF}$

where $\left\{ \begin{array}{l} F_{IN} \text{ is the VCO frequency} \\ F_{REF} \text{ is the reference frequency(5KHz)} \end{array} \right.$

2. Other input combinations will be defaulted to channel 10

DMD 5603

HANDSET FREQUENCIES (Mode=Low)

CH	CHANNEL DATA				RECEIVE			TRANSMIT		
	DA3	DA2	DA1	DA0	F _{RX}	F _{INI}	N*	F _{RX}	F _{INI}	N*
1	0	0	0	1	45.250	34.555	6911	48.250	48.250	9650
2	0	0	1	0	45.275	34.580	6916	48.275	48.275	9655
3	0	0	1	1	45.300	34.605	6921	48.300	48.300	9660
4	0	1	0	0	45.325	34.630	6926	48.325	48.325	9665
5	0	1	0	1	45.350	34.655	6931	48.350	48.350	9670
6	0	1	1	0	45.375	34.680	6936	48.375	48.375	9675
7	0	1	1	1	45.400	34.705	6941	48.400	48.400	9680
8	1	0	0	0	45.425	34.730	6946	48.425	48.425	9685
9	1	0	0	1	45.450	34.755	6951	48.450	48.450	9690
10	1	0	1	0	45.475	34.780	6956	48.475	48.475	9695

Notes : 1. $N^* = F_{IN} / F_{REF}$

where $\left\{ \begin{array}{l} F_{IN} \text{ is the VCO frequency} \\ F_{REF} \text{ is the reference frequency (5KHz)} \end{array} \right.$

2. Other input combinations will be defaulted to channel 10

DMD 5603

TEST AND APPLICATION CIRCUIT

