

FEATURES

- 20 - 700 MHz
- 0.4 mA, +5 VDC
- 22 nSec Switching Speed
- 10 nSec Rise Time
- 10, 20, or 30 dB Steps
- TTL Driver



MODEL NO.
DAT15015

GaAs 1 Section Attenuator

1 BIT

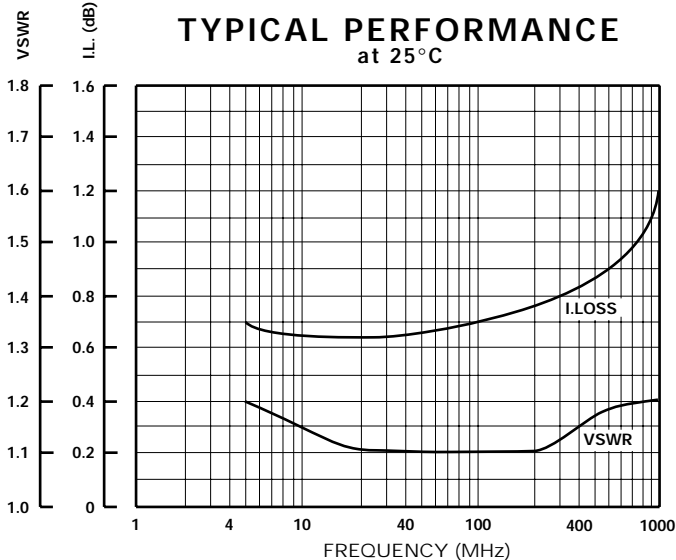
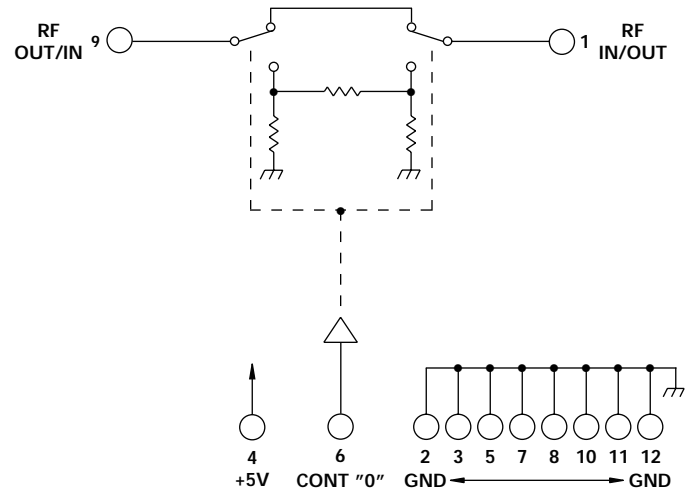
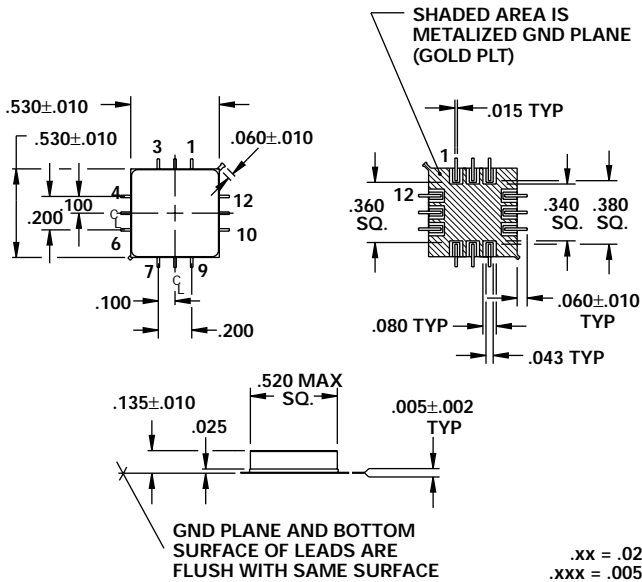

TABULATION CHART	
Part Number	Attenuation
DAT15015	10 dB ± .35 dB
DAT15016	20 dB ± .55 dB
DAT15017	30 dB ± .75 dB

GUARANTEED PERFORMANCE

Parameter	Min	Typ	Max	Units	Conditions
Operating Frequency	20		700	MHz	
DC Current		0.2	1.0	mA	At +5 VDC Supply
Control Type		TTL			1 Line, Reverse Logic Available Logic "0" = Thru Logic "1" = Attenuation
Control Current	High Low	0 0	±20 ±20	µA	V _{IH} = +3.0 V V _{IL} = +0.5 V
Insertion Loss		1.0	1.5	dB	
Attenuation	LSB Range Accuracy			dB dB dB	See Table See Table See Table
VSWR		1.1/1	1.25/1		
Impedance		50		OHMS	
Switching Speed		20	35	nSec	50% TTL to 90% / 10% RF
Transition (Rise/Fall) Time		10		nSec	90% / 10% or 10% / 90% RF
Switching (Video) Transients		45		mV	Peak Value
Intercept Points	2nd 3rd	+68 +35		dBm dBm	140 MHz / 200 MHz 140 MHz / 100 MHz
RF Power	Operate No Damage	+12	+10 +27	dBm dBm	0.1 dB Compression
Operating Temperature		-55	+25	+125	°C TA